

SCALE  
1/48

**TOMAHAWK IIb**  
"Ace of African Front"

**ACADEMY**  
HOBBY MODEL KITS

12235

※ You can download the latest version of an instruction manual for this model by visiting [www.academyhobby.com](http://www.academyhobby.com), clicking the link for 'INSTRUCTION & DOWNLOAD' and entering the item number. 본 제품의 조립 중 궁금한 점은 [www.academy.co.kr](http://www.academy.co.kr) 접속 후 메뉴 '자료실' ---> '프라모델' 로 이동하여 해당 제품명을 입력하면 최신의 설명서를 확인 할 수 있습니다.



	GS1 CREOS	ACRYLIC HOBBY COLOR	Mr. COLOR	LIFE COLOR	HUMBRDL	TESTO / MODEL MASTER	ENAMEL	ACRYL	
1	INTERIOR GREEN FS 34151		351	UA004		1715	4736		인테리어 그린
2	RED FS 11138	H<327>	327	LC06	19	2041	4714		빨강색
3	YELLOW FS 13958	H<329>	329	LC03	69	2063	4721		노랑색
4	FLAT BLACK	H<12>	33	LC02	33	1749	4768		무광 검정색
5	AZURE BLUE		370	UA098	109	2048			아주르 블루
6	METALLIC GRAY	H<28>	61	LC76	53	1795	4681		메탈릭 그레이
7	SILVER	H<8>	8	LC74	11	1790	4678		은색
8	BURNT IRON	H<38>	61	LC26	53	1795	4681		버트 아이런
9	MIDDLE STONE	H<71>	21	UA097	225	2052			미들 스톤
10	DARK EARTH FS 30111	H<72>	369	UA092	29	2054			다크 어스

**<READ THIS BEFORE YOU BEGIN>**

- Study the instructions before assembling. - Check the fit of each piece before cementing into place.
- Do not use too much cement to join parts. - Never use cement or paint near open flame.
- Open a window or make area well ventilated when cement or paint is in use.
- Tear up and throw away the empty plastic bags to avoid danger of suffocation for little children.

**<ALLGEMEINE HINWEISE>**

- Die Anordnung der Bauteile ist aus den Zeichnungen der Anleitung ersichtlich.
- Die Teile vor dem Verkleben ungeklebt zusammenhalten, um ihren paßsitz zu prüfen.
- Klebstoff nicht zu dick auftragen. - Klebstoff und Farben niemals in der Nähe einer Flamme verwenden.
- Während der Bemalung mit Spritzpistole oder Pinsel für frische Luftzufuhr. z.B. Öffnen des Fensters, sorgen.
- Bausatz von kleinen Kindern fernhalten. Verhüten Sie, daß Kinder irgendwelche Bauteile in den Mund nehmen oder Plastikfolien über den Kopf ziehen.

**■ 조립하기 전에**

- 부품을 조립하기 전에 설명서를 잘 읽어본 후 조립한다. - 부품을 자를 때는 칼이나 니퍼로 깨끗이 잘라준다. - 접착제를 사용할 곳과 사용하지 않는 곳에 주의하고 너무 많이 비르지 않도록 한다.
- 접착하기 전에 부품을 맞추어 확인한 후 조립한다. - 에나멜 페인트나 접착제를 사용할 때는 창문을 열어 환기를 시키고 화기를 멀리한다. - 사용 후 남은 부품은 어린 아이들의 손에 닿지 않도록 잘 처리한다.



「READ THIS BEFORE YOU BEGIN」  
「ALLGEMEINE HINWEISE」  
「LISEZ CE QUI SUIT AVANT DE COMMENCER LE MONTAGE」  
「組み立てる前に」  
「조립하기 전에 당겨 주십시오」

**<LISEZ CE QUI SUIT AVANT DE COMMENCER LE MONTAGE>**

- Etudier les schémas d'assemblage. - Contrôler que chaque pièce soit bien conforme avant de la coller à sa place.
- N'utilisez pas trop de colle pour réunir les pièces. - Ne jamais manipuler la colle ou peinture à proximité d'une flamme.
- Aérer soigneusement la pièce où vous peignez(ou/ou la fenêtre).
- Après avoir sorti les pièces du sac en plastique, déchirer le sac afin d'éviter que les enfants ne le mettent sur la tête et ne s'étouffent.

**〈組み立てる前に〉**

- 組み立てる前に説明書をお読み下さい。 - 部品をランナーから切りはずす時は模型用ニッパーとカッターを使用します。
- 接着剤を少し少なめに使うことがきれいに仕上げるコツです。 - 接着する前に部品を食わせてゆかめします。
- 接着剤や塗料を使用する時はときどき窓を開けて換気をお願いします。
- 組み立て後の部品やビニール袋は小さな子供の手の届かない安全な所に保管して下さい。

**⚠️ 보호자 분들은 반드시 읽어 주십시오.**

- 조립하기 전에 취급 설명서를 펼쳐 읽어 내용을 충분히 이해한 상태에서 조립하여 주십시오.
- 부품을 자를 때는 해당번호를 확인한 뒤 니퍼 등으로 깨끗이 잘라 주십시오. 칼을 이용하여 부품을 다듬고 자를 경우 손을 다치지 않도록 세심한 주의를 기울여 주십시오.
- 작은 부품 따위를 절대로 입에 넣지 마십시오. 잘못하여 삼킬 경우 질식 등의 위험이 있습니다. ● 자칫 먹을 우려가 있으므로 3세 미만의 어린이에게는 절대로 주지 마십시오.
- 잘라낸 부품은 깨끗이 다듬어 조립하고 남은 쓰레기는 분리하여 잘 버려 주십시오. ● 기능상 부득이하게 휘어나온 부분이 있을 수 있습니다. 취급 시 충분한 주의를 기울여 주십시오.
- 제품 및 부품이 포장된 비닐봉지는 개봉 후 즉시 어린이의 손에 닿지 않는 곳에 잘 버려 주십시오. 머리에 뒤집어쓰거나 얼굴을 덮을 경우 질식의 위험이 있습니다.
- 색칠 및 접착을 위하여 모형을 도료 및 접착제 등을 사용할 때에는 창문을 열어 환기를 시키고 화기를 멀리하여 주십시오. 사용하고 남은 도료 및 접착제는 어린이의 손이 닿지 않는 곳에 잘 보관하여 주십시오.

- Before starting to assemble, read the instruction manual very carefully to understand well everything of the instructions.
- Before cutting a part off sprue, check the part number again and use proper tool such as nipper to cut it clearly. Take care not to be hurt in use of modelling knife to cut or trim parts.
- Never put small parts in the mouth to avoid any danger of suffocation by accidentally swallowed ones. ● Never let children less than 3 years old have it to avoid any danger of taking it.
- The product may have some protruding parts for functional reasons and take care of handling it always.
- After cutting a part off sprue, trim it clearly to assemble and the wastes should be properly sorted to dispose.
- Plastic bags packed with the product and parts should be disposed in a proper place immediately to keep out of children to avoid any danger of suffocation by pulling it over head or putting it over face.
- Before using modelling colors or cement, open windows to keep the room well ventilated and do not use near fire or flame. After using them, keep in a proper place out of children.



**주의  
WARNING!**



붙여줍니다.  
Glue parts  
Coller  
Kleben



붙여지지 않습니다.  
Do not cement  
Ne pas coller  
Nicht kleben



3  
중반을 포함한다.  
Repeat operation  
Répéter l'opération  
Wiederholung



전사지를 붙입니다.  
Decals  
Décalomanies  
Abziehbilder



9  
무게추를 붙입니다.  
Add weight  
Ajouter  
Gewicht



구멍이나 홈을 이웁니다.  
Use filler  
Matriquer  
Schließen



잘라냅니다.  
Cut away  
Couper  
Schneiden



선택합니다.  
Optional parts  
Choix  
Auswahlmöglichkeit



반대쪽도 포함합니다.  
Repeat for opposite side  
Répétition de la page  
Wiederholung für gegenüberliegende Seite



구멍을 뚫어줍니다.  
Make hole  
Faire un trou  
Öffnen



주의합니다.  
Be careful  
Faire attention  
Hier Vorsicht



색상 및 전사지 붙이기 번호  
Painting scheme number  
Numéros de la liste de peintures  
Lackscheme nummer

1

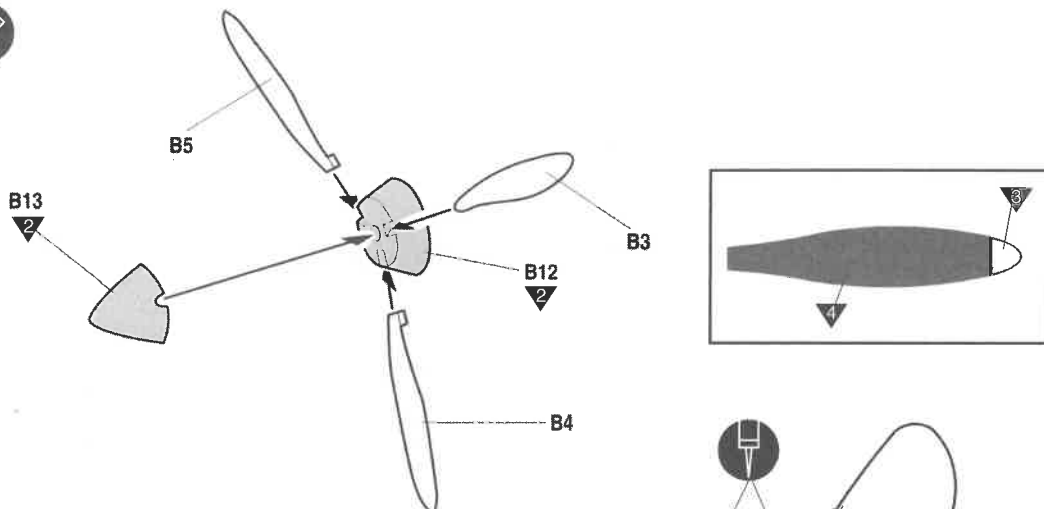

2

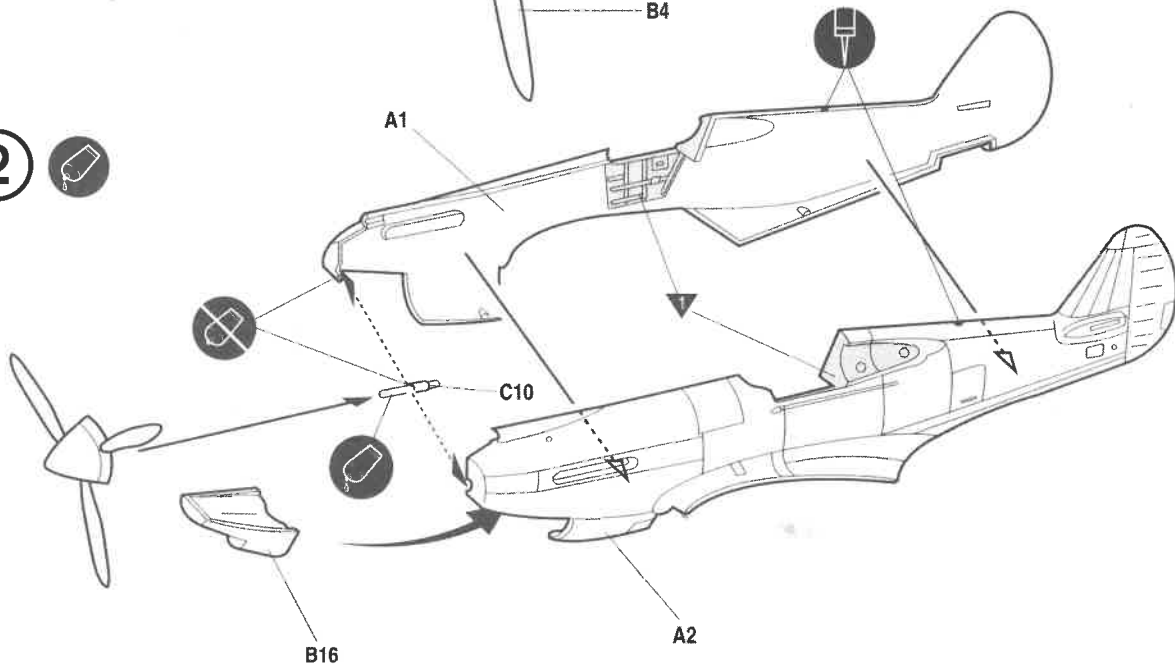

3

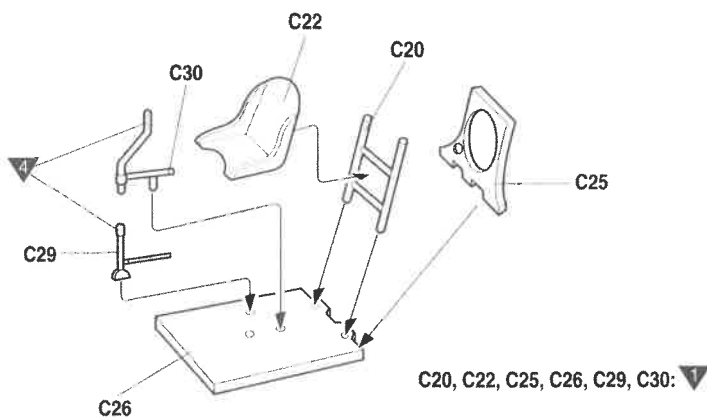

C20, C22, C25, C26, C29, C30: ▼

4

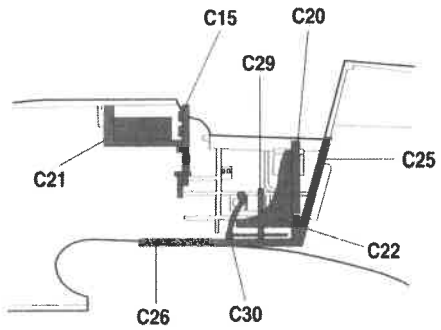
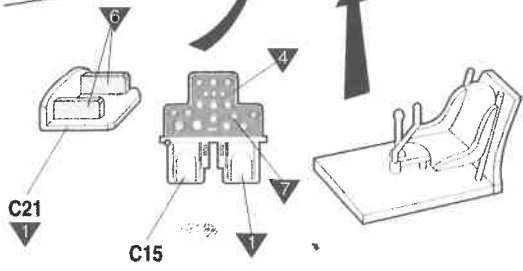
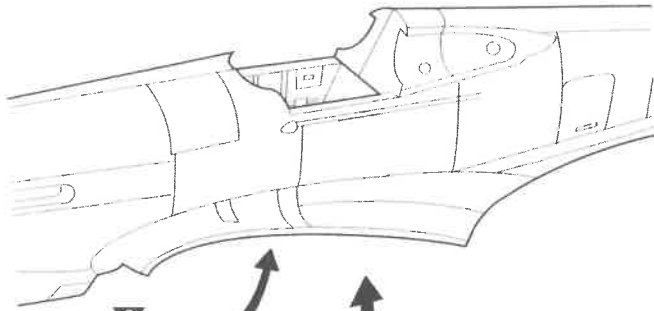

5

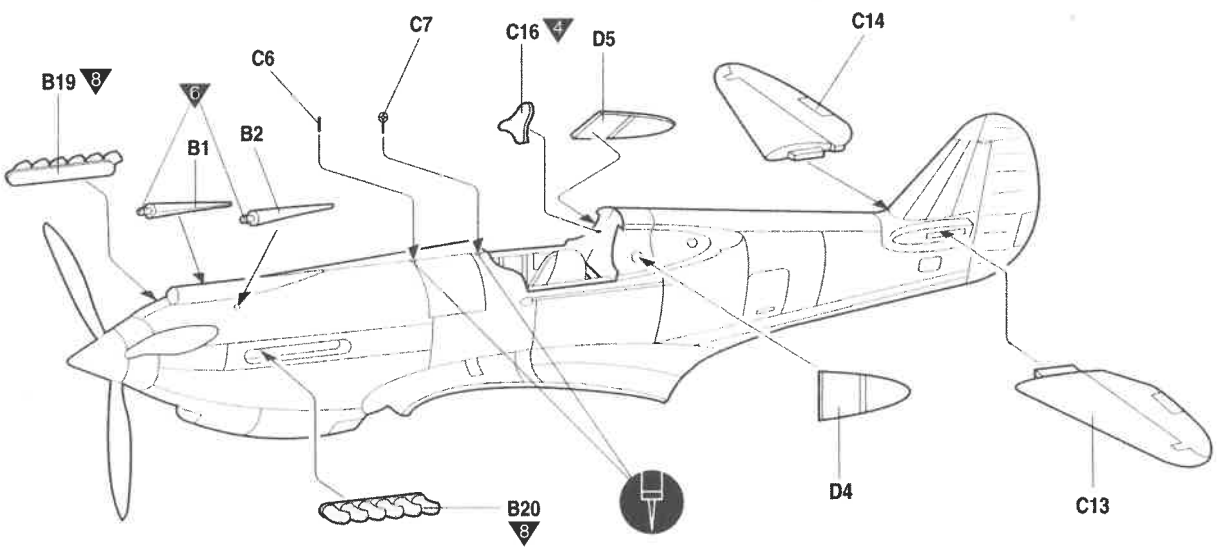

6

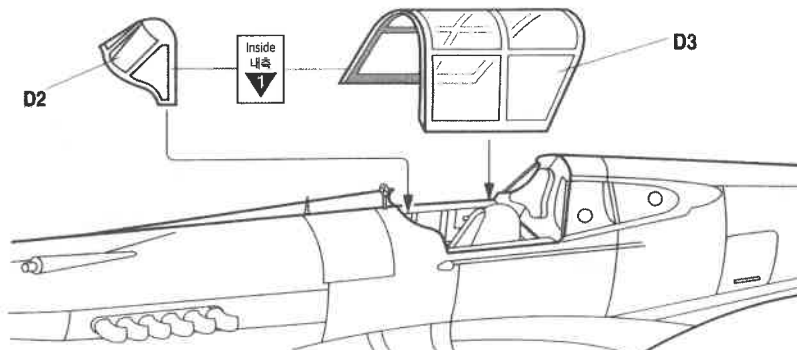

7

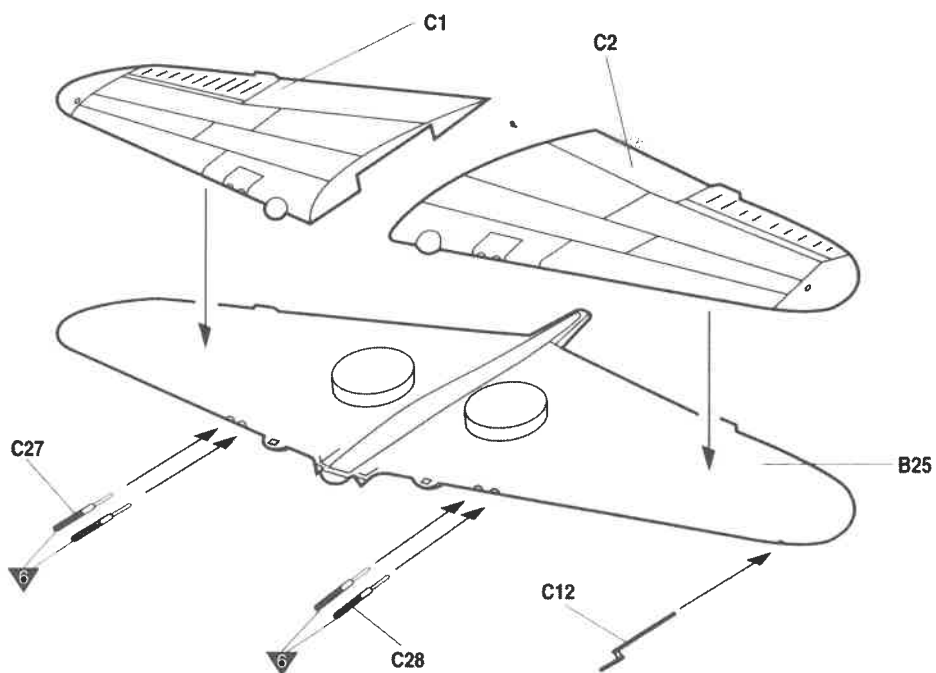

8

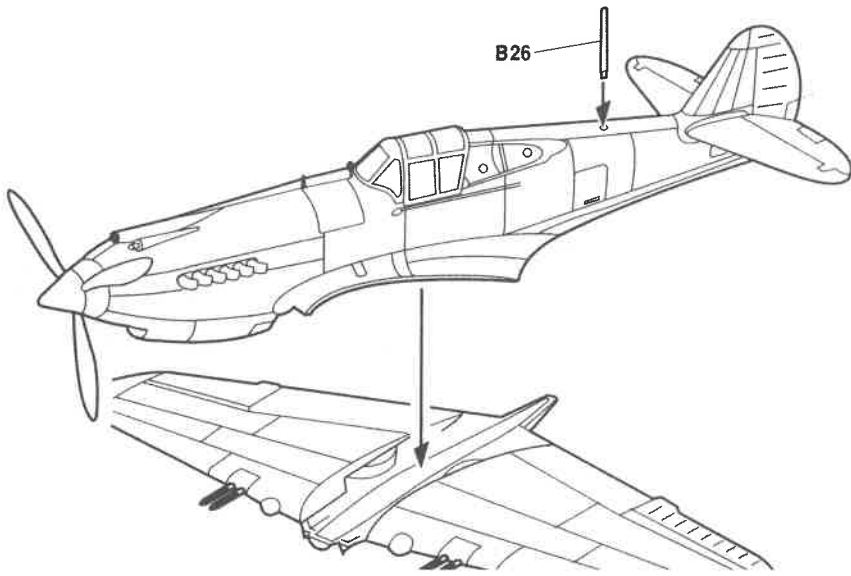

9

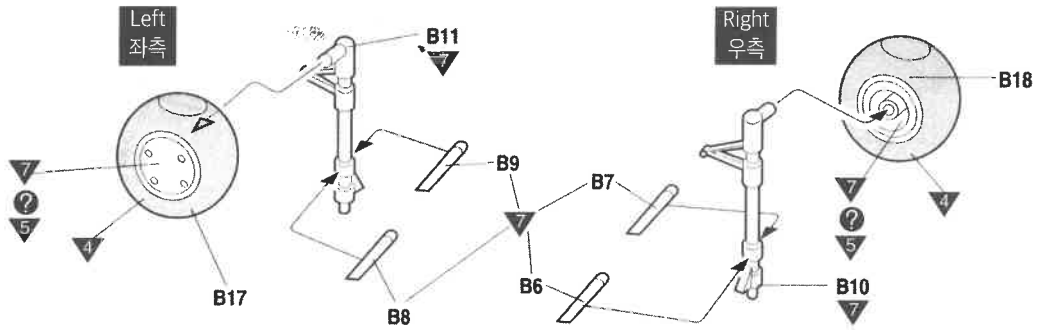

10

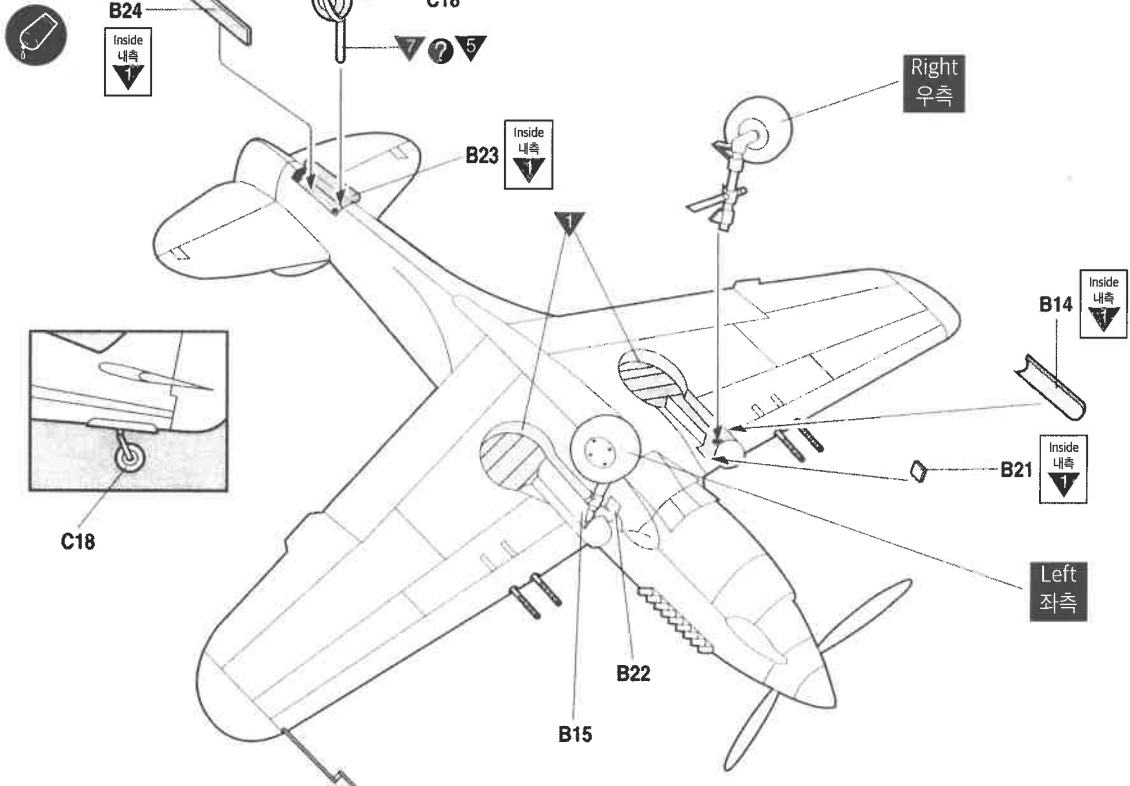

- 1** Tomahawk IIb, AN413, RAF Flt Off Jack Bartle of No. 112 "SHAR" Sqn, Egypt, Oct. 1941.  
 토마호크 IIb AN413, 이집트주둔 영연방공군 제112 "샤크" 비행대 소속, 잭 바틀 소위 탑승기, 1941년 10월.

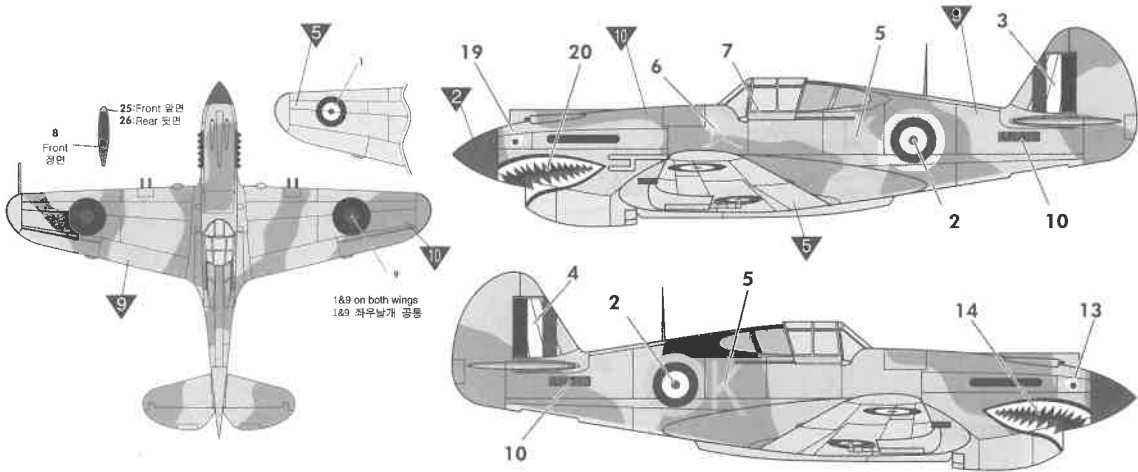

Jack Bartle, Australian Ace with 6 kills remotes to be Flt Lt and No. 112 Sqn, commander after Flt Lt Clive Caldwell in May, 1942. 6기격추기록을 가지는 호주출신의 에이스 잭 바틀은 1942년 5월 클리브 칼드웰 소령의 뒤를 이어 소령진급과 함께 112비행대의 지휘를 맡는다.

- 2** Tomahawk IIb, AK498, RAF Flt Lt Clive Caldwell of No. 250 "SUDAN" Sqn, Lybia, Nov~Dec. 1941.  
 토마호크 IIb AK498, 리비아주둔 영연방공군 제250 "수단" 비행대 소속, 클리브 칼드웰 소령 탑승기. 1941년 11~12월.

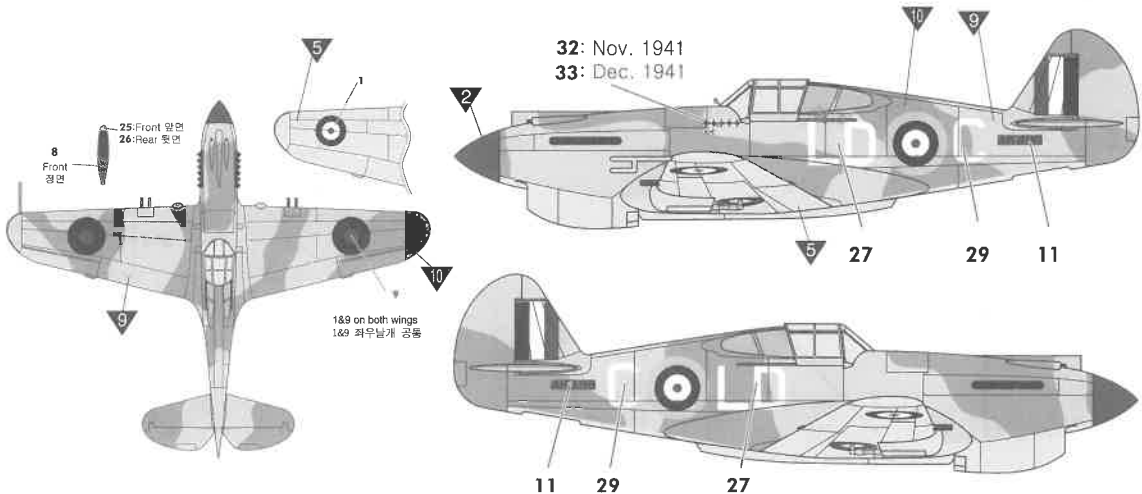

Group Captain Clive Caldwell, an Australian Hero Ace with 28.5 kills, was assigned to Sqn No.250 when he shot down 5 Ju-87 Stukas at one combat in Dec, 1941. In late 1942 he was sent back to RAAF to fight against Japanese threat on Pacific Theatre, flying Spitfires.

최종계급 대령인 클리브 칼드웰 역시 호주출신 조종사 가운데 최고기록인 28.5기의 기록을 갖는다. 250비행대 소속으로 리비아에 전개중이던 1941년 12월 5일 한 번의 전투에서 5기의 Ju-87 슈투카를 격추시킨다. 이후 호주공군으로 복귀하여 태평양전선에서 스피트파이어로 일본군과 싸웠다.

- 3** Tomahawk IIb, AK402, RAF Plt Off Neville Duke of No. 112 "SHARK" Sqn, Egypt, Nov. 1941.  
 토마호크 IIb AK402, 이집트주둔 영연방공군 제112 "샤크" 비행대소속, 네빌 듀크 소위 탑승기, 1941년 11월.

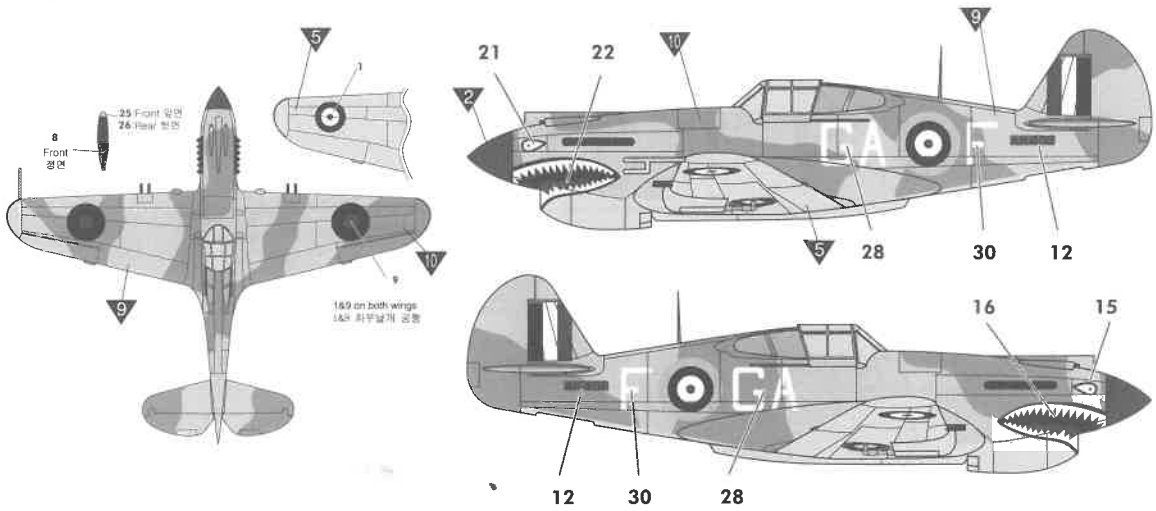

- 4** Tomahawk IIb, AK578, RAF Plt Off Neville Duke of No. 112 "SHARK" Sqn, Egypt, Jan-Feb. 1942.  
 토마호크 IIb AK578, 이집트주둔 영연방공군 제112 "샤크" 비행대소속, 네빌 듀크 소위 탑승기, 1942년 1~2월

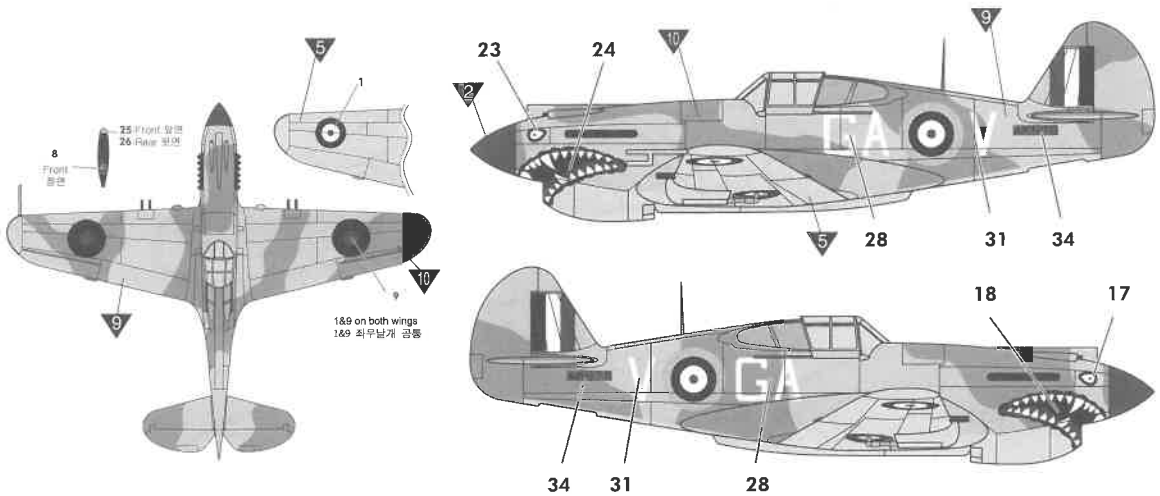

Squadron Leader Neville Fredrick Duke, scoring at least 27, was 19 when he became ace on 30, Nov, 1941 on AK402, finishing the flight by being shot down by German Ace, Otto Schulz. He kept flying mainly in AK578 and Kittyhawk, Spitfires, to be a Mediterranean Theatre's top Allied fighter ace. Later he worked for Hawker as a test pilot, recording top speed with Hunter. 최종계급 대령인 네빌 프레드릭 듀크가 AK402를 조종하며 다섯번째 격추를 기록, 에이스가 되던 1941년 11월 30일 그는 아직 19세였으며, 그 비행은 독일공군의 에이스인 오토 슐츠에게 격추당하는 것으로 끝나버렸다. 그럼에도 아래의 AK578 및 키티호크, 스피트파이어 등을 조종하며 지중해전선의 연합군 최고 에이스에까지 이른다. 이후 호커사의 시험조종사로 근무하였고, 헌터를 조종하여 세계최고속도를 기록하기도 한다.

**A**

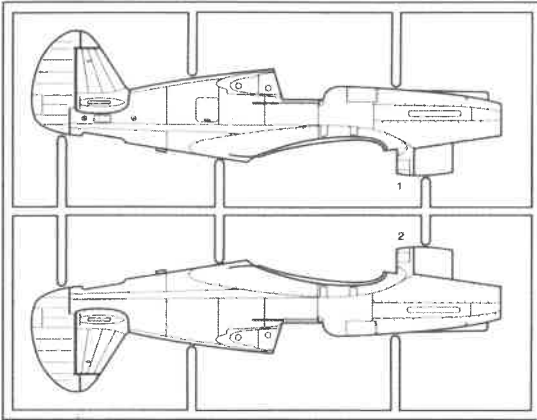

**D**

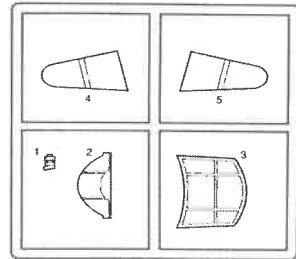

**B**

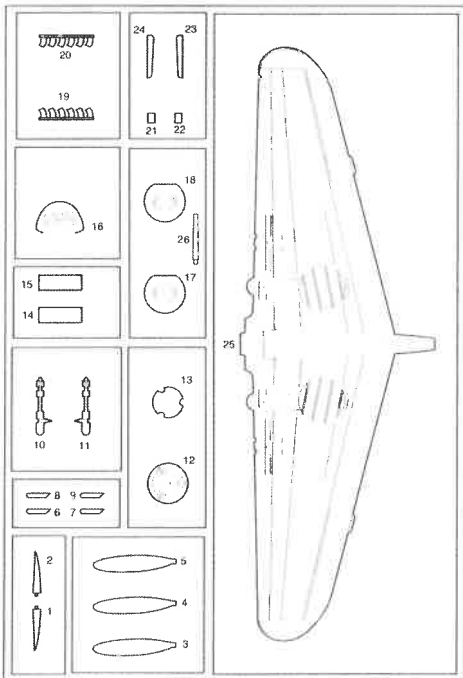

**C**

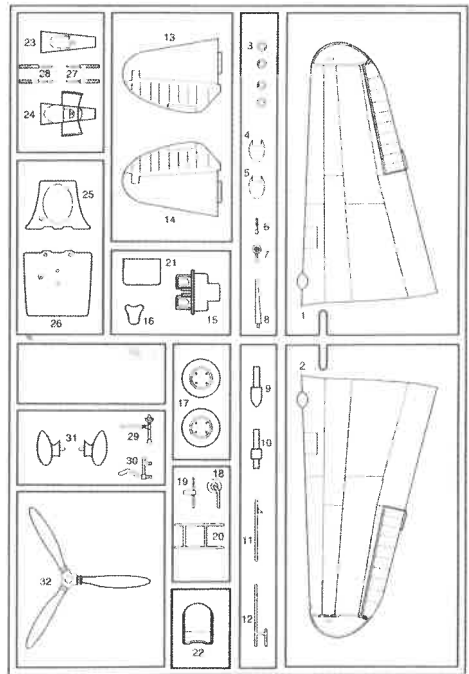

●Decal/ 전사지

●Unused parts/불필요 부품  
C3, C4, C5, C8, C9, C11, C17, C19  
C23, C24, C31, C32, D1

**ACADEMY**  
HOBBY MODEL KITS

**ACADEMY**  
ACADEMY PLASTIC MODEL CO., LTD.  
고객상담번호: 031-850-8555



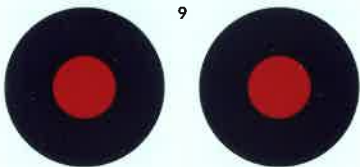
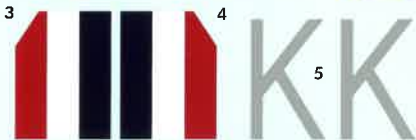

27

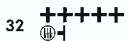

6 7

8

28



29

30

31