

Armoured Weapons Carrier

Wiesel 1 A1/A2 TOW



****Special thanks to: Bjorn Weber,
Ralph Zwilling, Thomas Hartwing,
Uwe Hellmann.**



In 1969, West German Army initiated a project that a light armored vehicle can be air-transportable by transport planes and helicopters and for airborne troops use. There were five manufacturers submitting bids for this project. The contract was eventually awarded to the Porsche in 1974. Porsche designed this vehicle to be capable of and quick repair and part replacement for each system of this vehicle. Their design also use many commercial parts including a Volkswagen engine. The prototype was officially designated "Wiesel" in 1983.

Wiesel is small-sized and with 2.8 tons combat weight, far below than 6 tons original weight limit set by the German Army. These features make it possible that many medium transport helicopters or heavier ones can accommodate wiesel in cargo compartment or airlift under the belly. Wiesel also can be air-dropped by transport planes with shock absorbing cushion and parachute and easily loaded by common tank carrier. With these abilities and conveniences of deployment, 343 Wiesels was produced in 1990 to 1992. 210 Wiesels were mounted with US made TOW missiles, was designated Wiesel 1 TOW. The other 133 Wiesels were mounted with Rheinmetall MK 20 Rh 202 20mm cannons, was designated Wiesel 1 MK 20. They were delivered to German army Fallschirmjaeger and active in United Nations Peacekeeping operations around the world.

Early production Wiesel used tracks that consists of rubber band with steel wire reinforcements. It was less durable and its use ended in 1995. Later, Wiesel was upgraded with new tracks that a German company Diehl developed for Wiesel -Diehl type 622 tracks. To enhance self-protection ability, A MG3 machinegun was mounted on Wiesel 1Tow A1. In 2006, Wiesel 1Tow A1 was upgraded to Tow A2 with a additional exterior wireless digital antenna and a GPS antenna.

1969年西ドイツ陸軍は、輸送機やヘリでの空輸が出来て、空挺部隊でも使用が可能な軽装甲車輦についての開発プロジェクトを開始した。このプロジェクトには5社が応じ、1974年最終的にポルシェ社が契約を獲得した。ポルシェ社は迅速な修理と部品交換を可能にした設計を施し、またフォルクスワーゲンのエンジンを含む、多くの民生用パーツを使用していた。試作車輦は1983年、正式に「ヴィーゼル」と命名された。

ヴィーゼルは非常に小さく、戦闘重量はわずか2.8トに抑えられており、西ドイツ陸軍が設定した重量の上限6トをはるかに下回っていた。この特長は、多くの中型輸送ヘリや大型ヘリの貨物室に収納したり、機体下部に吊るしての輸送を可能とした。また、衝撃吸収クッションとパラシュートを用いて輸送機からの投下も可能であり、もちろん通常の戦車輸送車による輸送も簡単に行うことができた。こういった運用上の扱いやすさもあり、1990年から1992年にかけて、343輦のヴィーゼルが生産されたのだった。このうち210輦にアメリカ製TOWミサイルが搭載され、ヴィーゼル1-TOWと名付けられた。そのほかの133輦には、ラインメタル製 Mk20-Rh202 20mm機関砲が搭載され、こちらはヴィーゼル1-MK20と呼称された。これらのヴィーゼルは西ドイツ陸軍降下猟兵部隊に配備され、国連平和維持活動にも参加し、世界の国で活躍したのである。

ヴィーゼルの初期生産型では、鋼のワイヤーをゴム製の材質で包み込んだ履帯を採用していたが、耐久性に問題があったため、1995年に使用を取りやめた。代わりにドイツのディール社が開発したType 622履帯が新たに採用された。このダブルピンタイプの履帯は、アルミニウム合金とゴムから成り、6000kmの走行が保証された。防御力増強のため、ヴィーゼル1TOW-A1にMG3機銃が搭載され、2006年にはデジタル無線アンテナとGPSアンテナが追加装備されて、ヴィーゼル1TOW-A2にアップグレードされたのだった。

1969年，西德軍方提出一種能透過運輸機與運輸直昇機直接裝載配合空降或輕裝快速部隊運用的輕型裝甲戰鬥車計畫。共有五家廠商參與了這個計畫的競逐，最後由保時捷在1974年取得合約，保時捷在設計中追求對車輛的各系統能夠進行快速維修的設計，大量使用包含福斯汽車引擎在內的商用零件，原型車在1983年被正式命名為鼬鼠。

鼬鼠的體型小巧，戰鬥重量僅2.8噸，遠低於軍方當時限制6噸的重量上限。許多中型以上直升機能夠在機身內或是以機腹吊掛方式裝載，也可以由運輸機藉由緩衝墊與降落傘來空中進行空投。一般的載重車輛也能輕易的搭載、運送鼬鼠裝甲車。由於擁有在布署運用上的種種便利，1990年至1992年間後鼬鼠共生產343輛，其中210輛搭載美國製的TOW飛彈，被稱做鼬鼠一型TOW。另外133輛安裝了一門萊茵金屬的MK 20 Rh 202 20mm砲，稱作鼬鼠一型MK 20。交付於德國空軍空降獵兵單位中服役，活躍於聯合國在各地的維持和平任務中。

初期的鼬鼠裝甲車採用橡膠材質包覆鋼絲的履帶，耐用性較低，在使用至1995年後改用德國迪爾公司為鼬鼠開發的622型雙銷履帶。履帶採用鋁合金與橡膠材質，具有六千公里的使用壽命。為了增加自衛的能力，鼬鼠一型TOW A1增設了一挺MG3機槍。2006年之後升級為TOW A2，車外增設了一具大型無線數據天線以及GPS天線。

Illustration:圖示說明



Method For Applying Decals:

1. Clean Model Surface With Wet Cloth.
2. Cut Out Of Decal Sheet And Dip Them In Warm Water For 15 Seconds.
3. Place it on proper position on model.
4. Slide off base paper leaving decals On Model With Wet Finger Tip.
5. Move Decals To Exact Position, Push Out Excess Water Under Decal With Soft Cotton Cloth.
6. When Decals Get Dry Then Complete.

水貼紙使用說明:

1. 將模型表面擦乾淨
2. 將貼紙剪下泡入溫水中浸泡約15秒
3. 將泡濕之貼紙取出置於欲貼處旁
4. 用指尖輕推貼紙表面使其滑出底紙
5. 將貼紙調整至適當位置並輕擦拭水份
6. 待其自然乾燥後即完成

Color list: 塗料表

Color	Brand	GSI Creos			Humbrol	Revell	Lifecolor
		Hobby Color	Mr.Color	Mr.Color Spray			
Bright blue	寶藍	H15	C65	J65	14	51	LC60
Bronze green	青銅綠		TC10				
Flat black	消光黑	H12	C33	J33	33	8	LC02
Flat red	消光紅	H13			73		LC06
Flat white	消光白	H11	C62	J62	34	05	LC01
Leather brown	皮革棕		TC11				
Olive drab(2)	橄欖褐	H78	C38	J38	66	46	UA106
Orange	橘	H14	C59		18	30	LC55
Red	紅	H3	C3	J3	19	31	LC56
Red brown	紅褐	H47/H406	C41	J41	160	383	UA085
Silver	銀	H8	C8	J8	11	90	LC74
Steel	黑鐵	H18	C28	J28	53	91	LC76
Tar black	瀝青		TC12				
Tire black	輪胎黑	H77	C137		85	302	LC02
Wood brown	木棕	H37	C43		169		FS12

1

Hull rear assembly
車體後部組裝

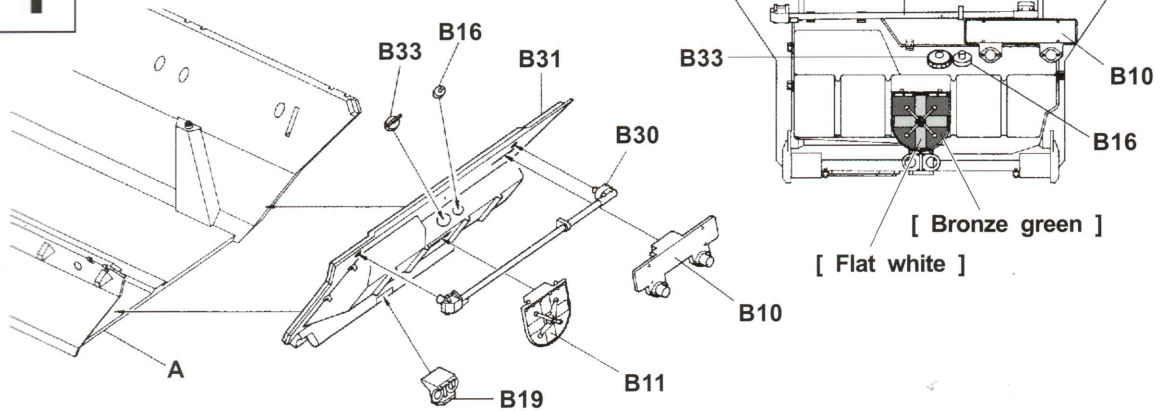

2

Tanks back seat
車後座椅

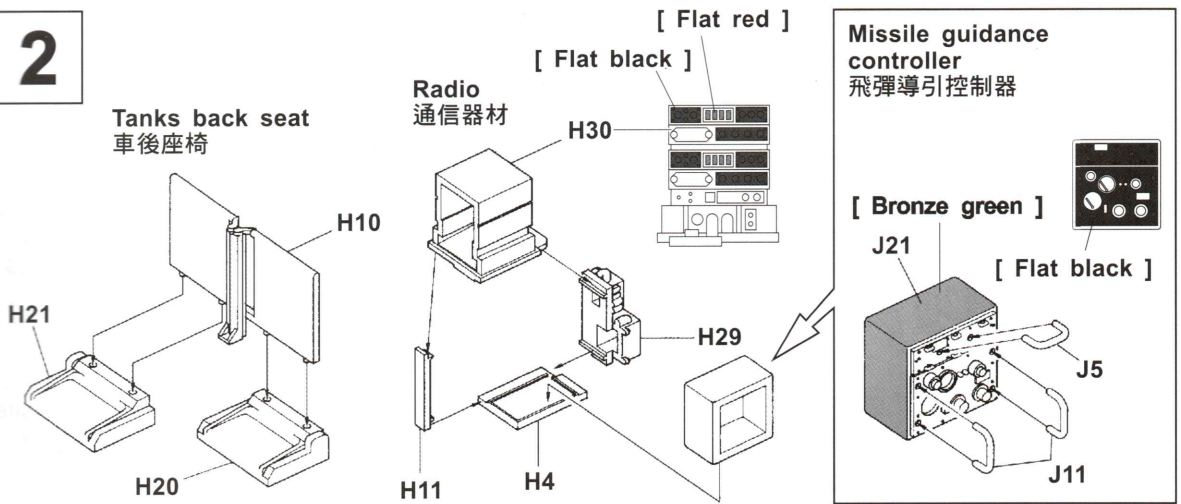

3

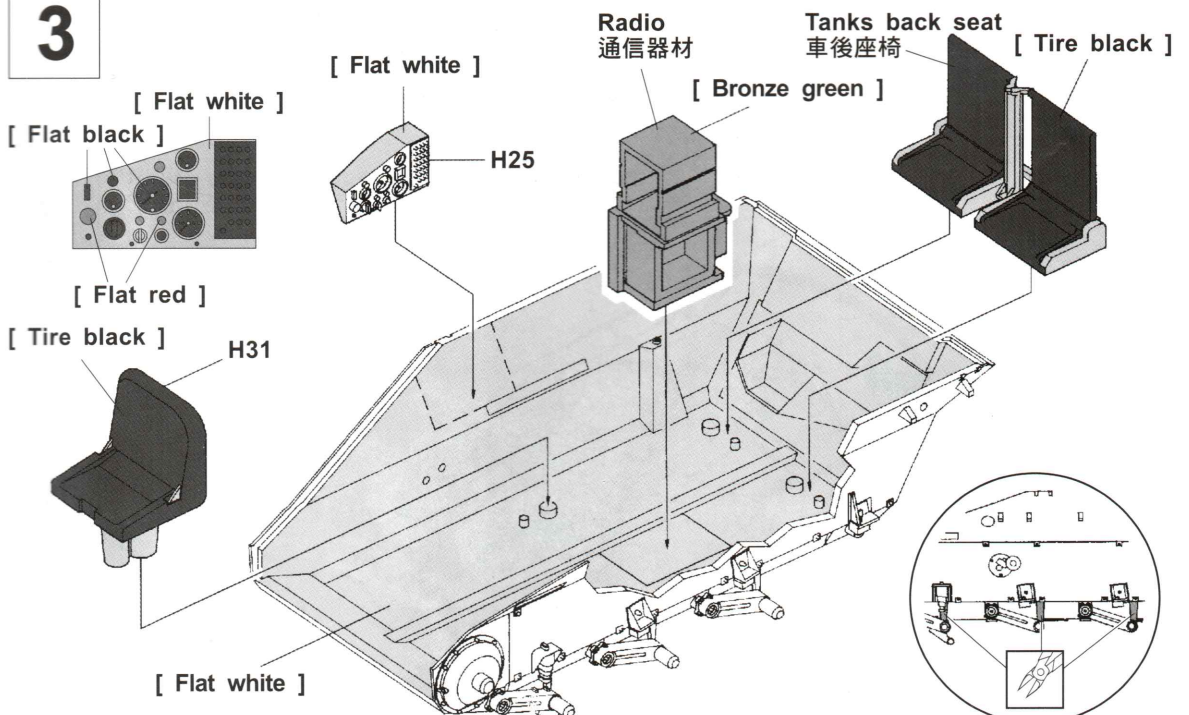

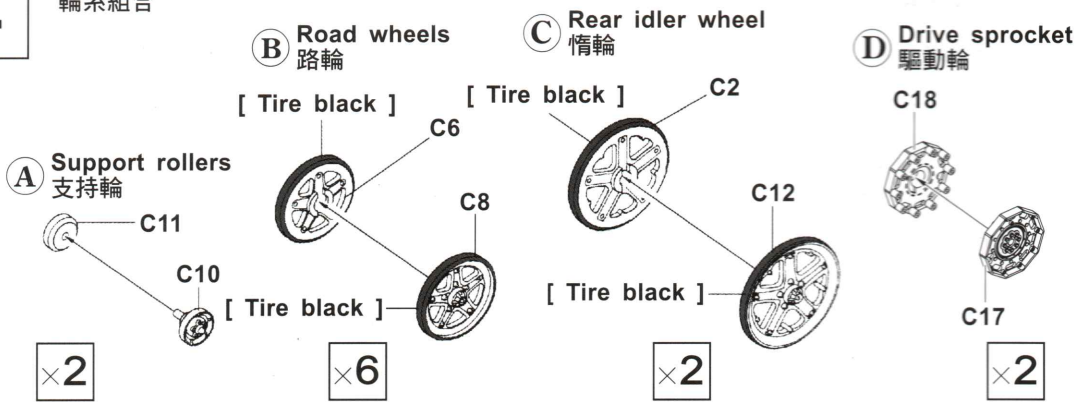
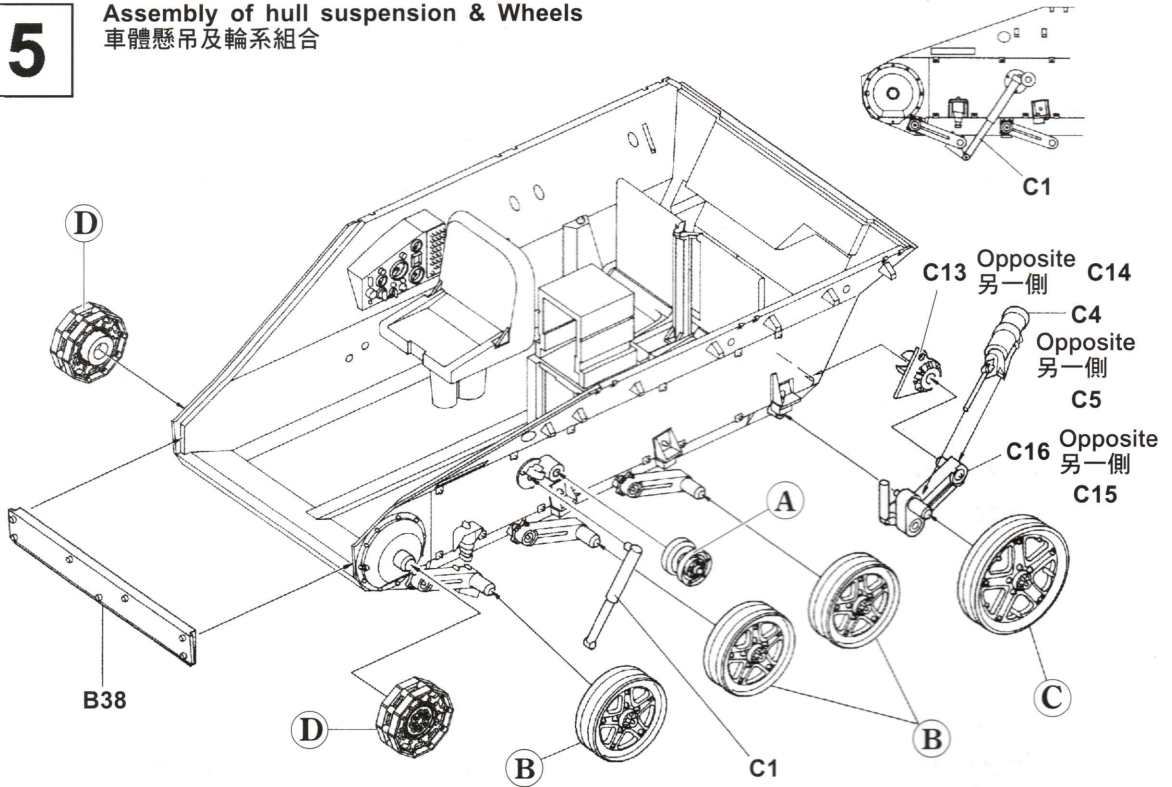
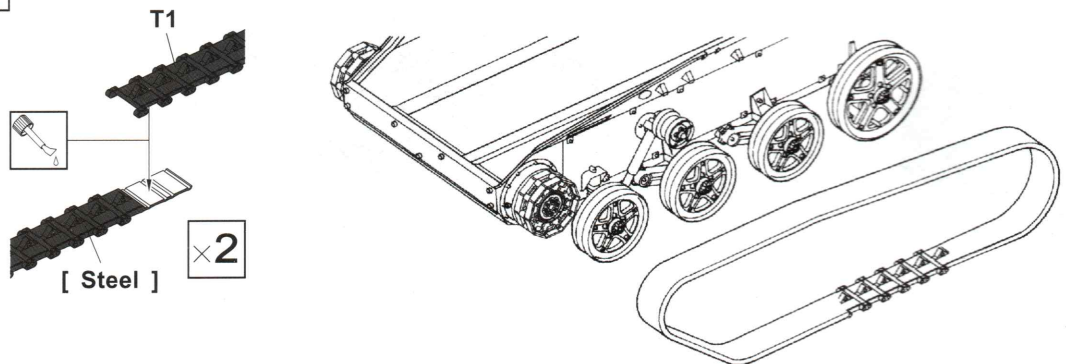
4**Wheel assembly
輪系組合****5****Assembly of hull suspension & Wheels
車體懸吊及輪系組合****6****Track assembly
履帶組裝**

7

Hull top assembly
車體上蓋組裝

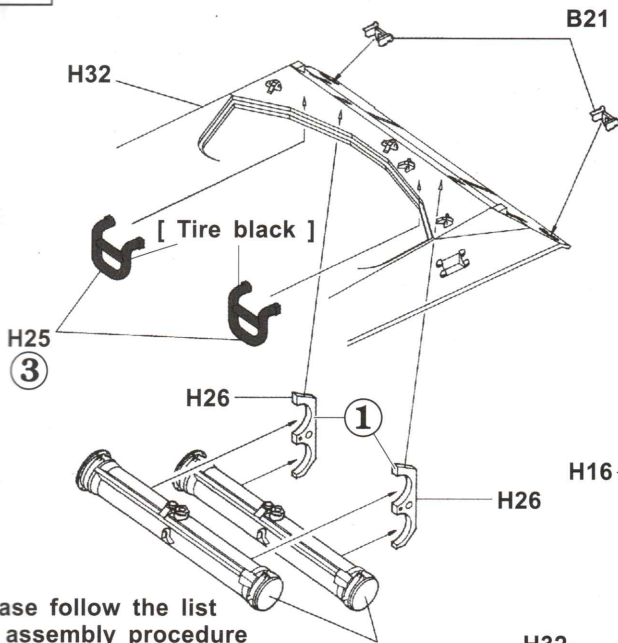

Please follow the list
for assembly procedure
請依照順序組合

- ① ➤ ② ➤ ③

② Missile body
飛彈彈體

Missile body & Tail Parts assembly
飛彈彈體和尾部零件組裝

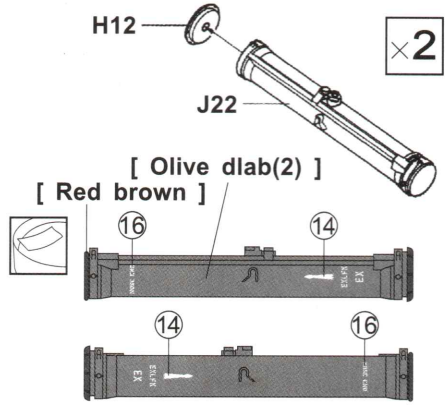

Steering
方向盤

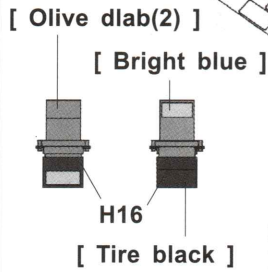
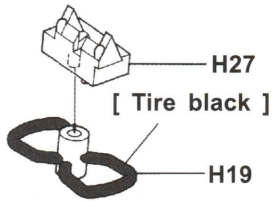

Steering
方向盤

8

Photo-etch for upper hull parts assembly
車體上部蝕刻片組裝

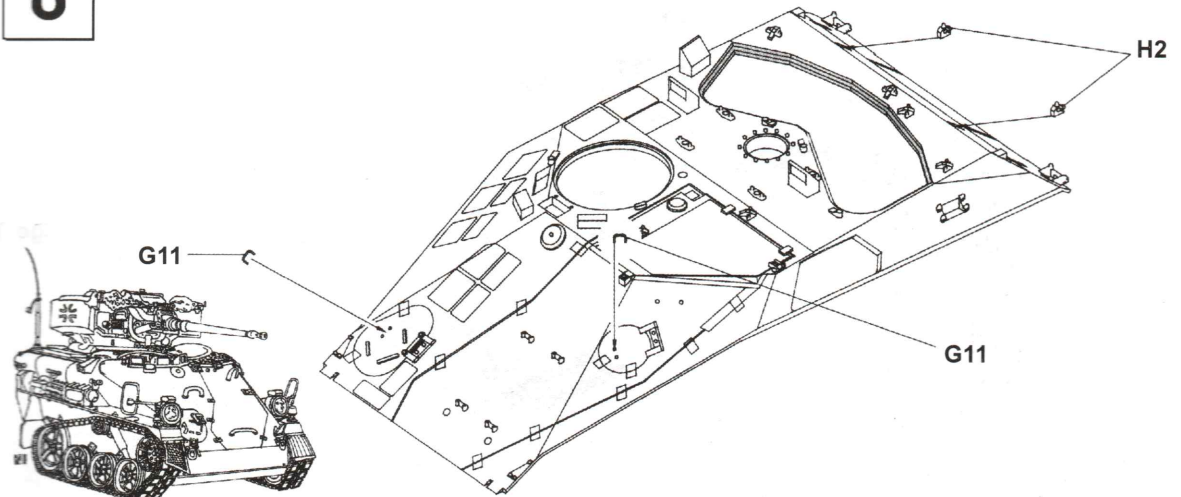

9

Assembly of upper & Lower hull
上下車體組裝

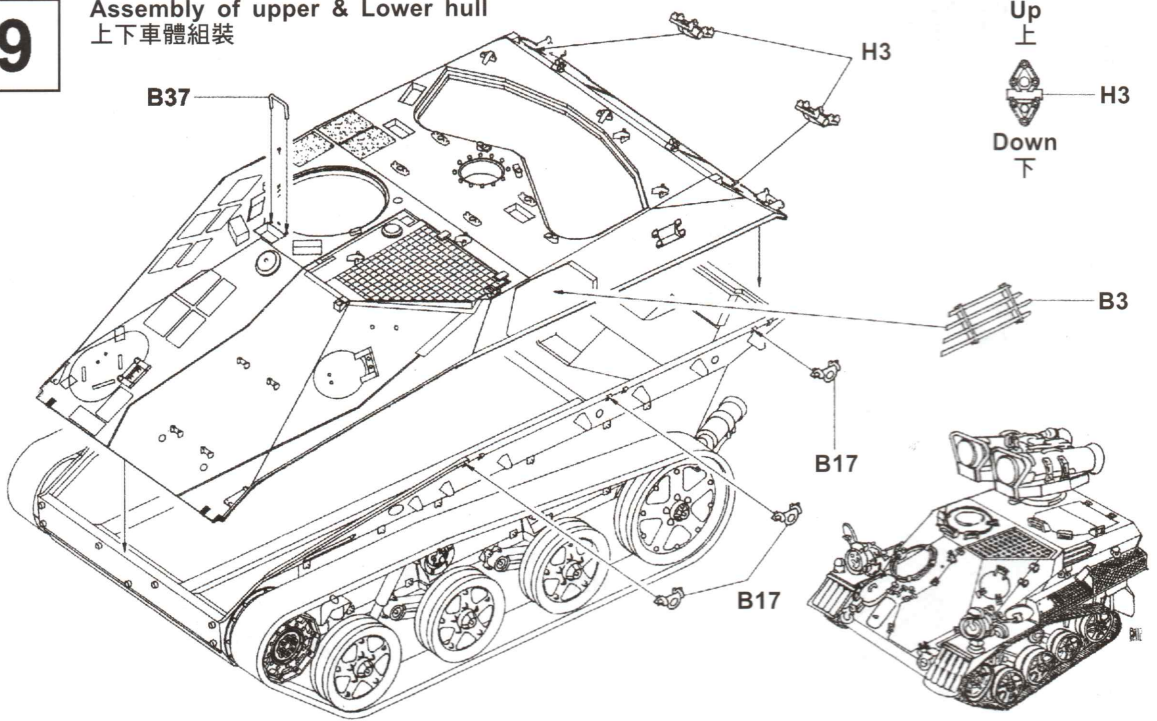

10

Assembly of right tank body
車體右側組裝

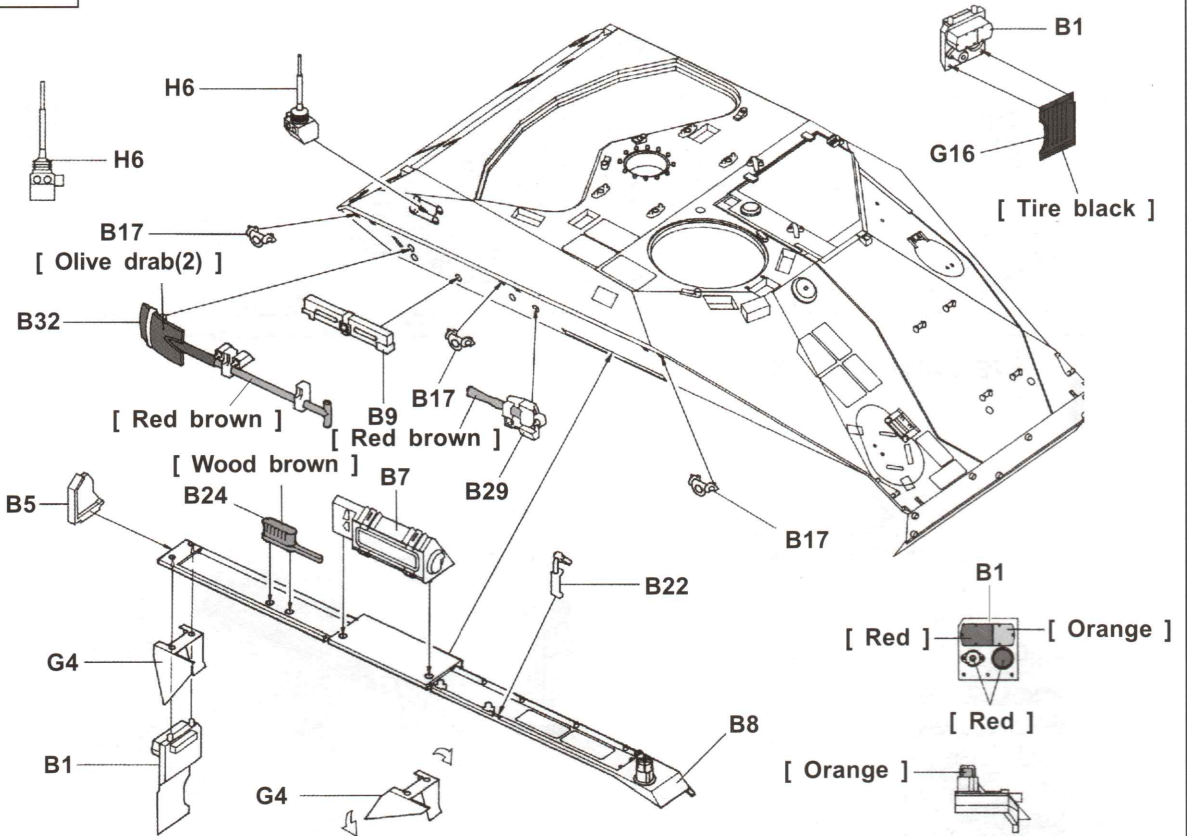

11

Assembly of Global positioning system 組裝全球定位系統

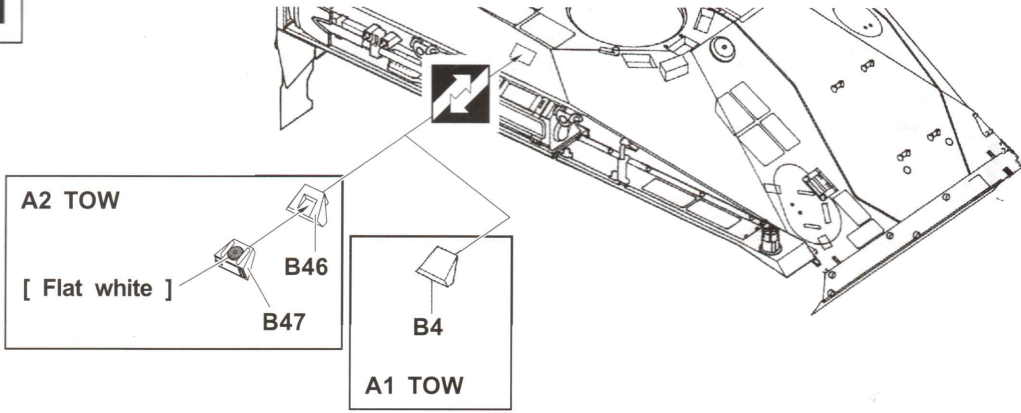

12

Exhaust outlet mesh 排汽管護網

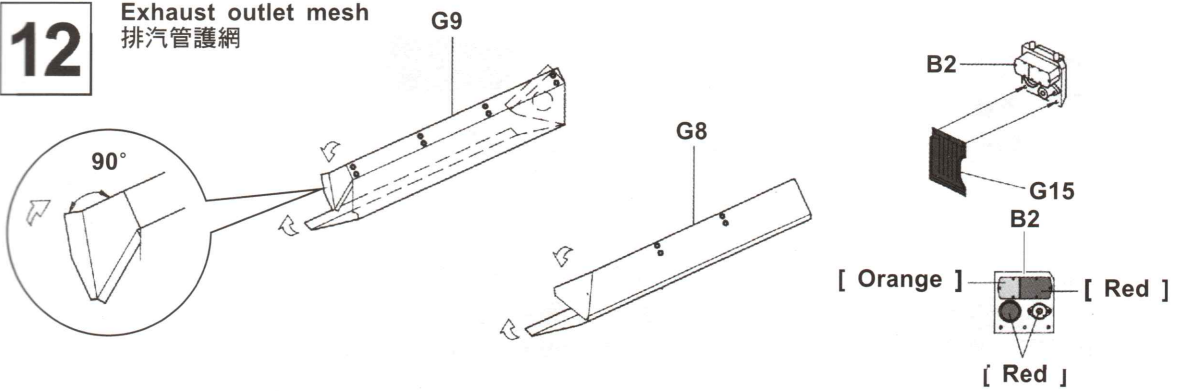

13

Assembly of left tank body 車體左側組裝

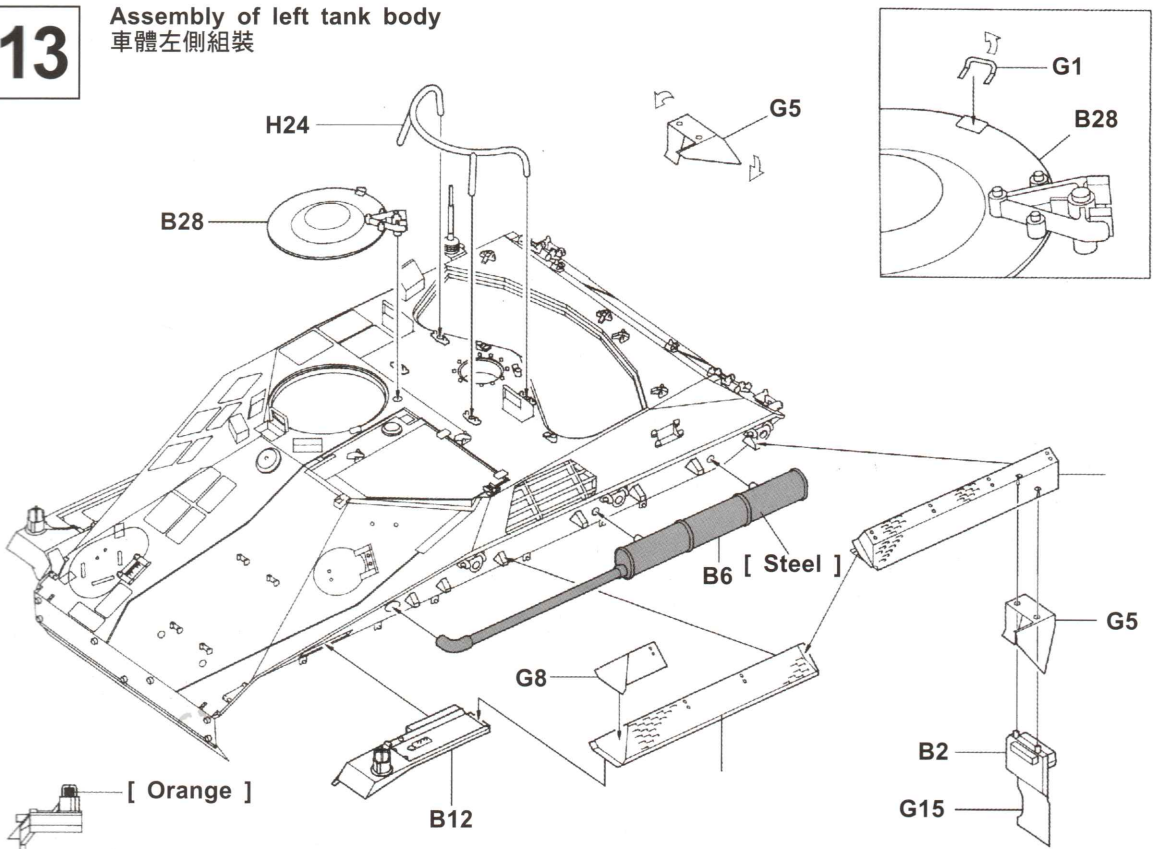

14

AN/TAS-4A Night vision 夜視鏡

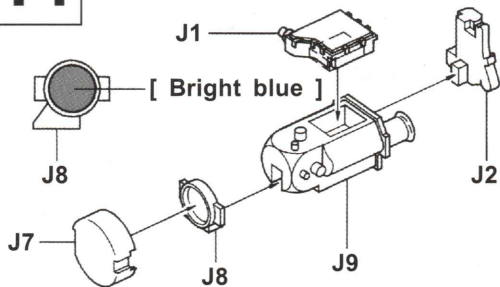

Range-launcher 瞄準鏡

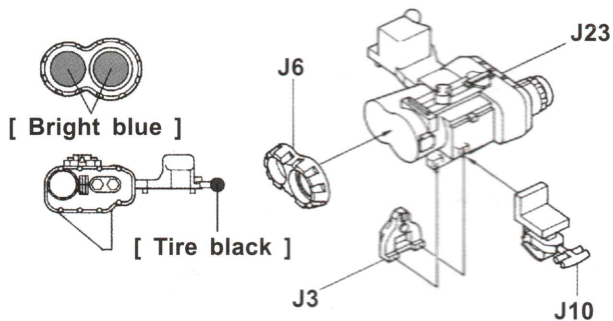

15

AWC Wiesel 1 TOW A1/A2 Tow Missile AWC Wiesel 1 TOW A1/A2 拖式飛彈

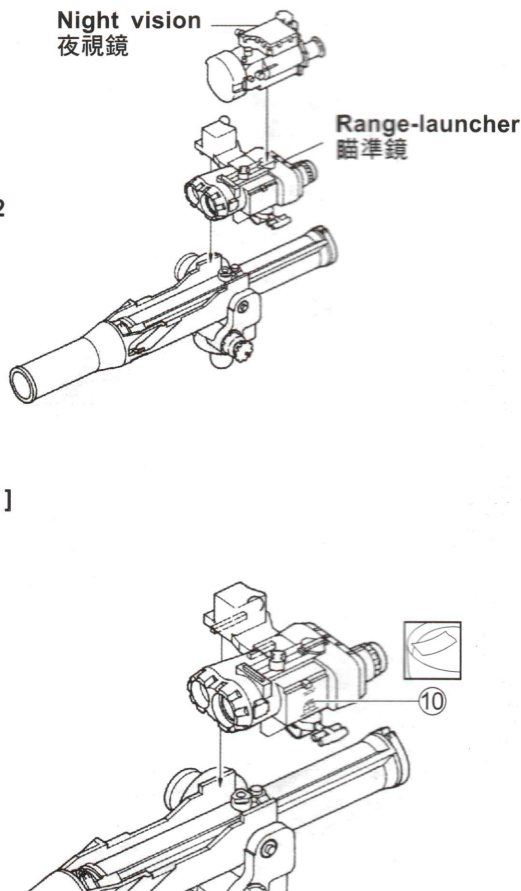
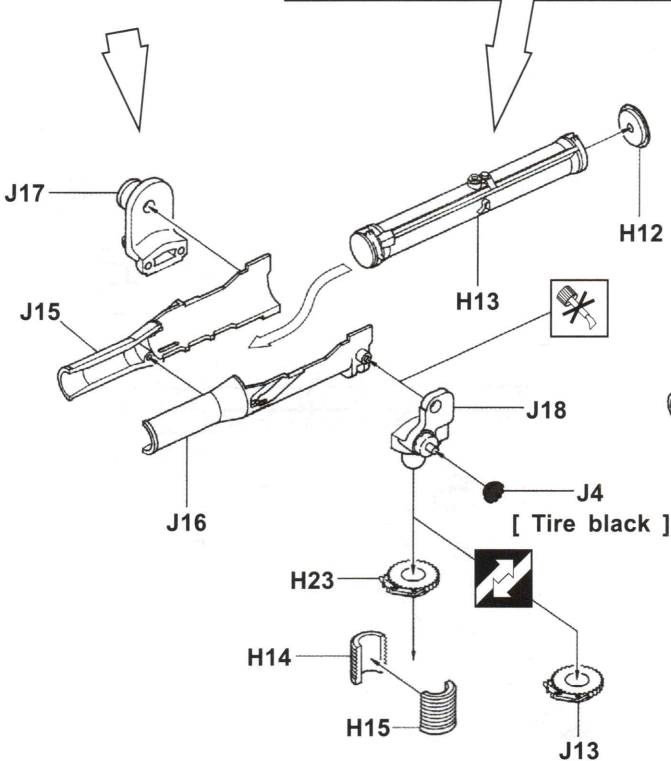
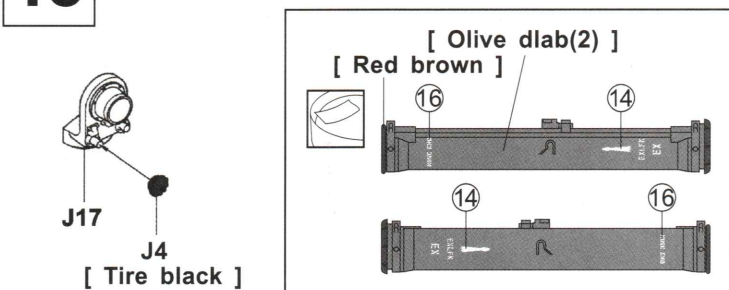

! ** Use the parts steps below for J13.
 ** 零件J13為選擇下個步驟時所使用。

16

The crews can leave the vehicle and operate Tow missile by standard tripod
車外野戰用拖式飛彈三腳架



** Use J14 as base size for G19 forming a hexagon.
** 以J14為基準將G19折成六角型。

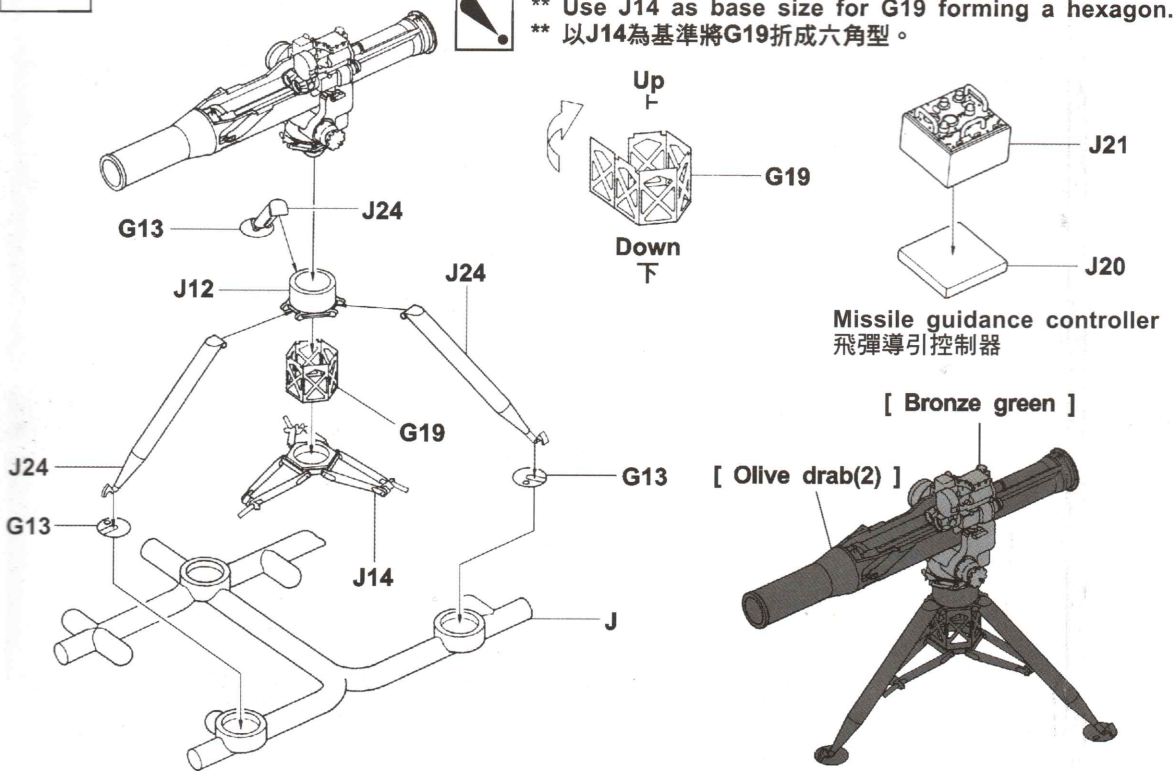

17

Assembly of control-room hatch
戰鬥室艙蓋組合

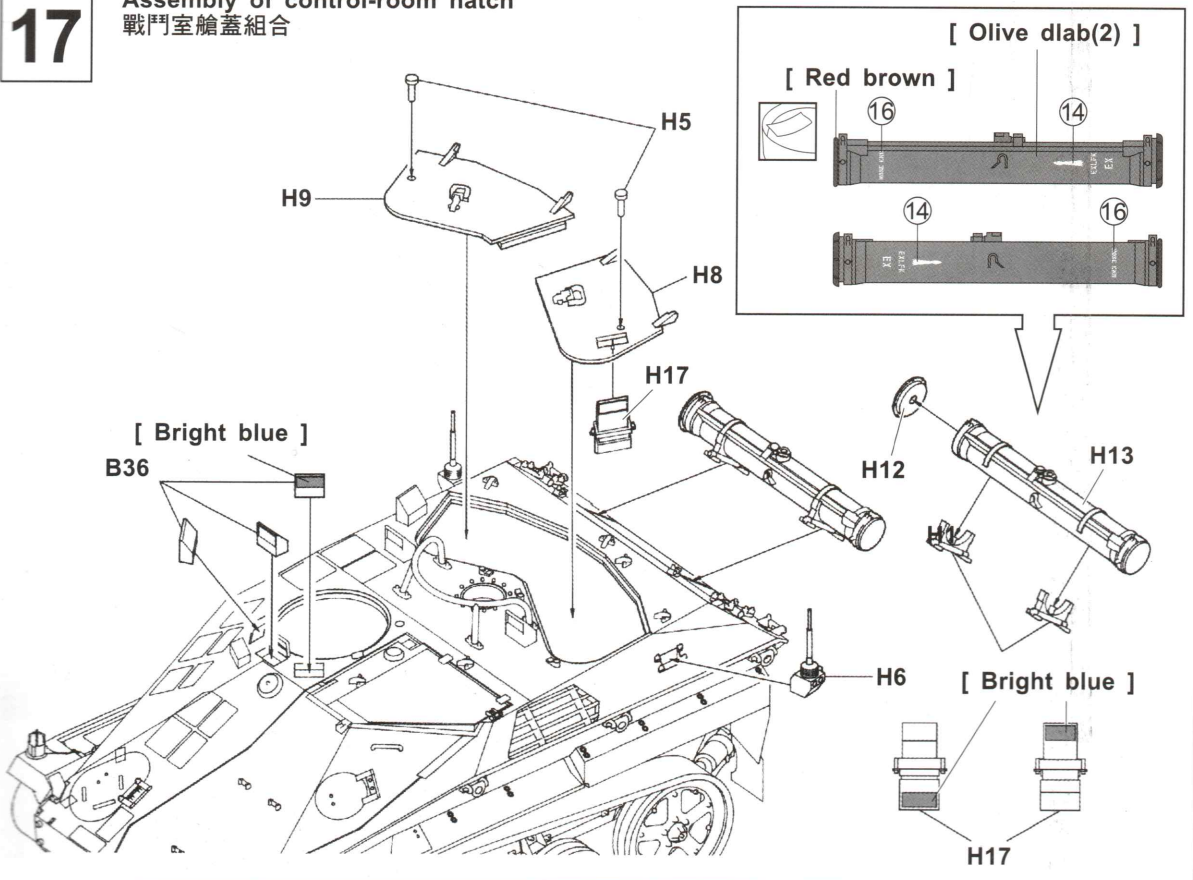

18

Assembly of front hull 車體前半部組裝

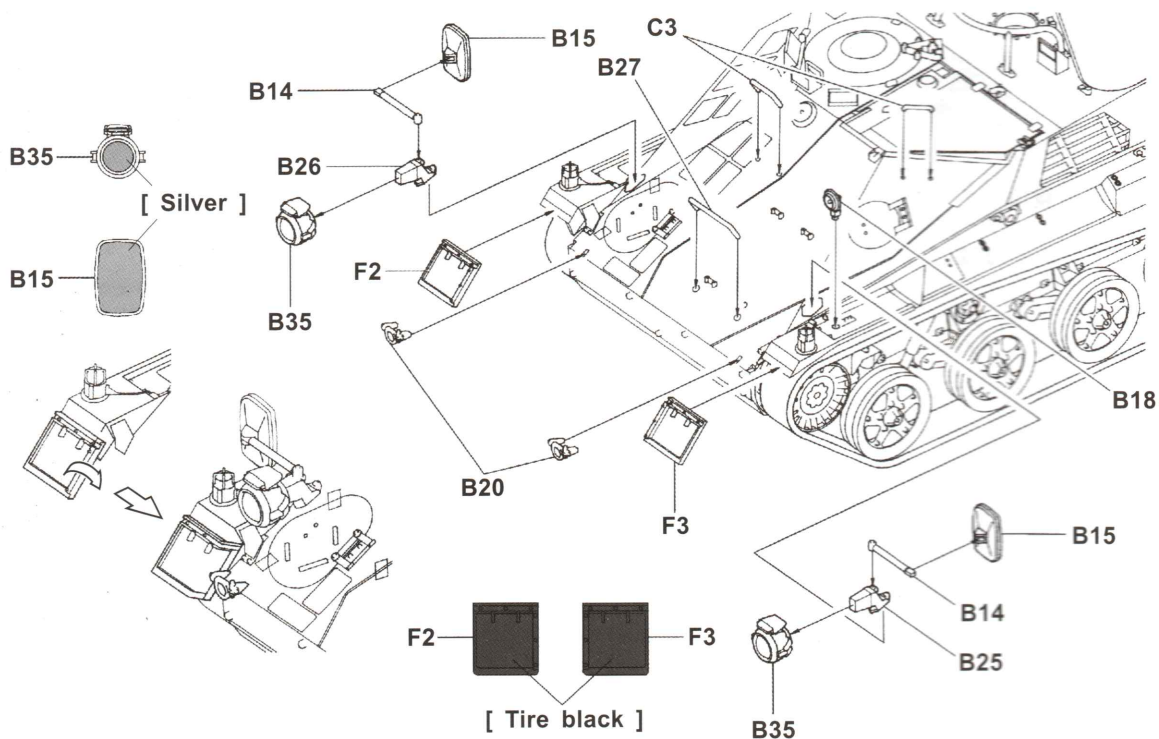

19

Hacksaw & axe 手弓鋸與手持斧

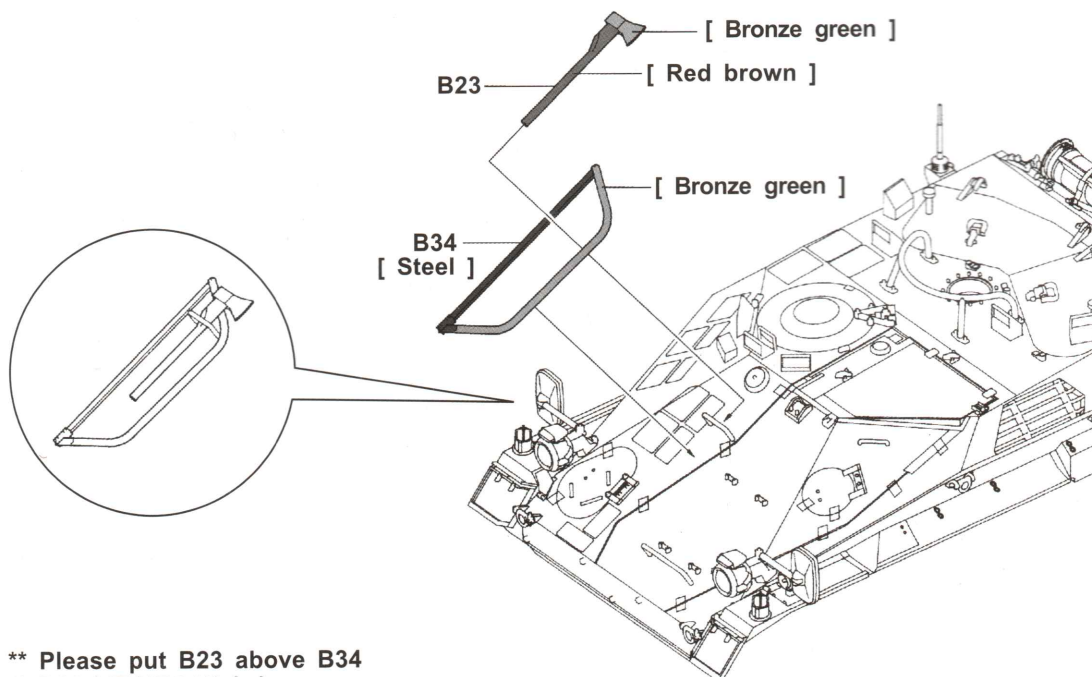

** Please put B23 above B34
** B23應置於B34的上方

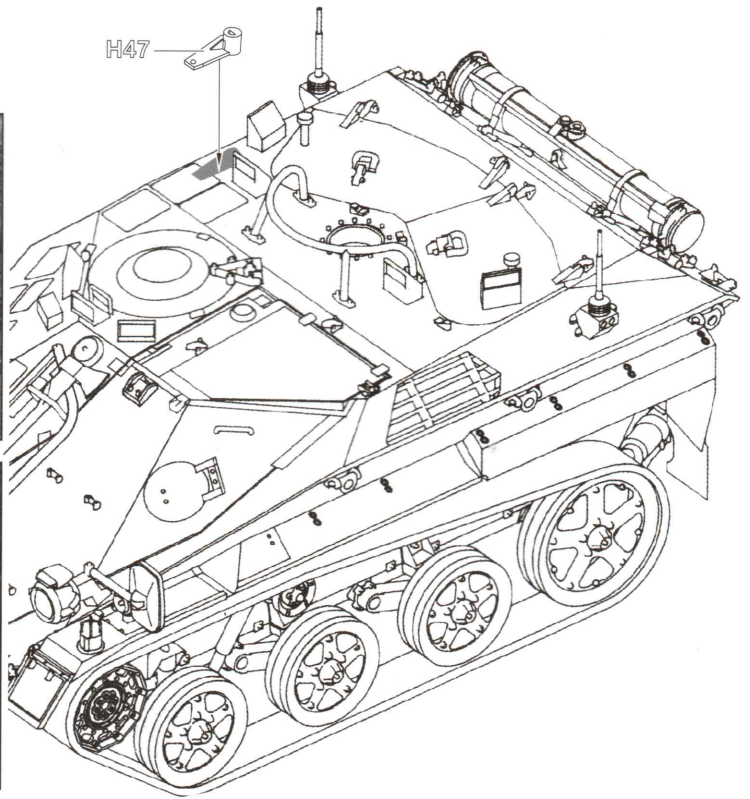
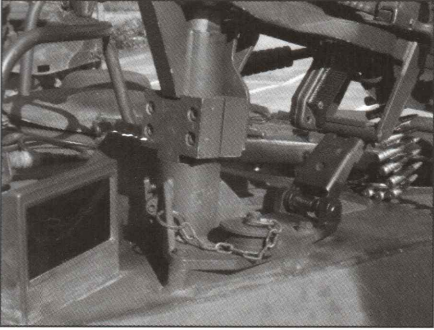
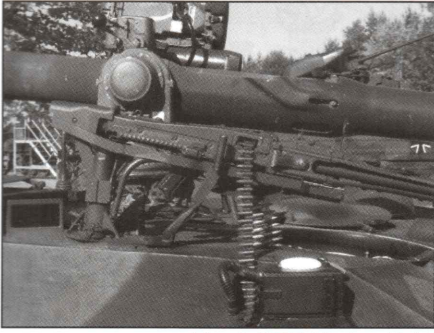

H47

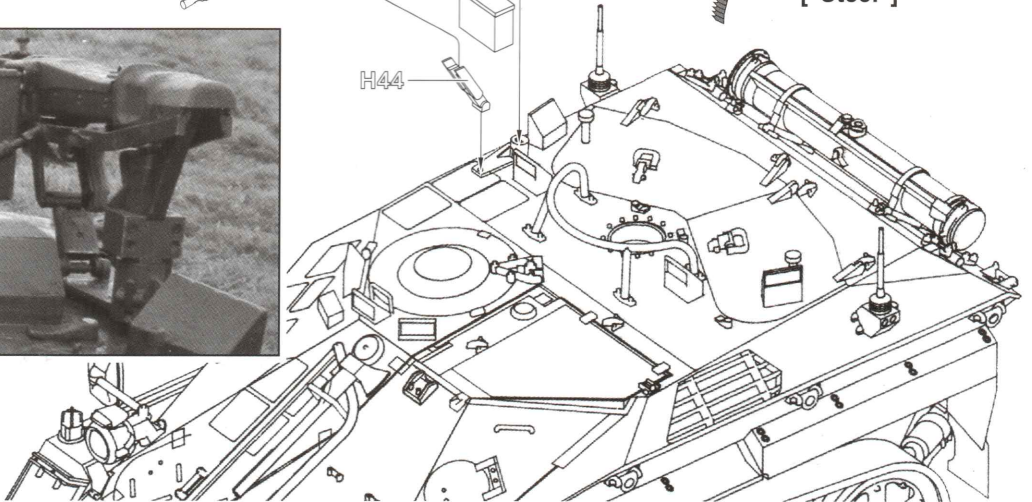
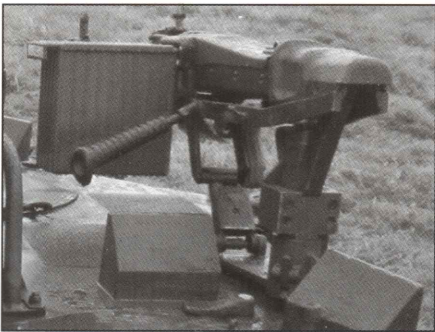
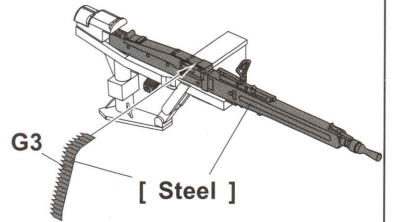
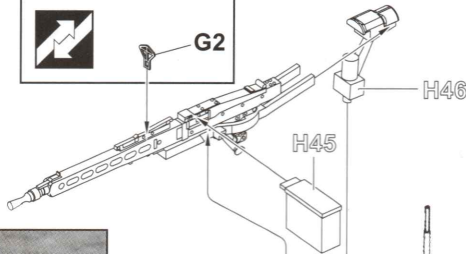
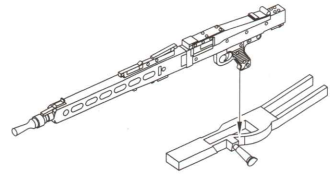
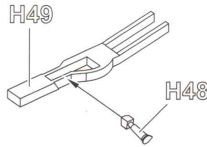
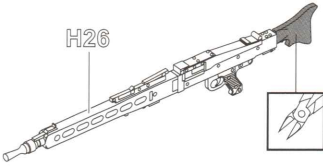

21

Assembly of Tow missile 組裝拖式飛彈

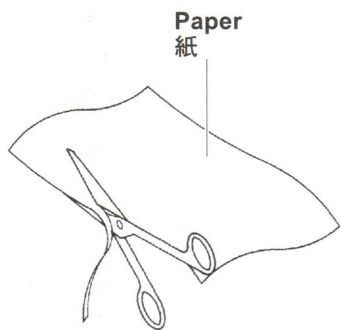

15mm
1mm
SIZE 1:1

15mm
2mm
SIZE 1:1

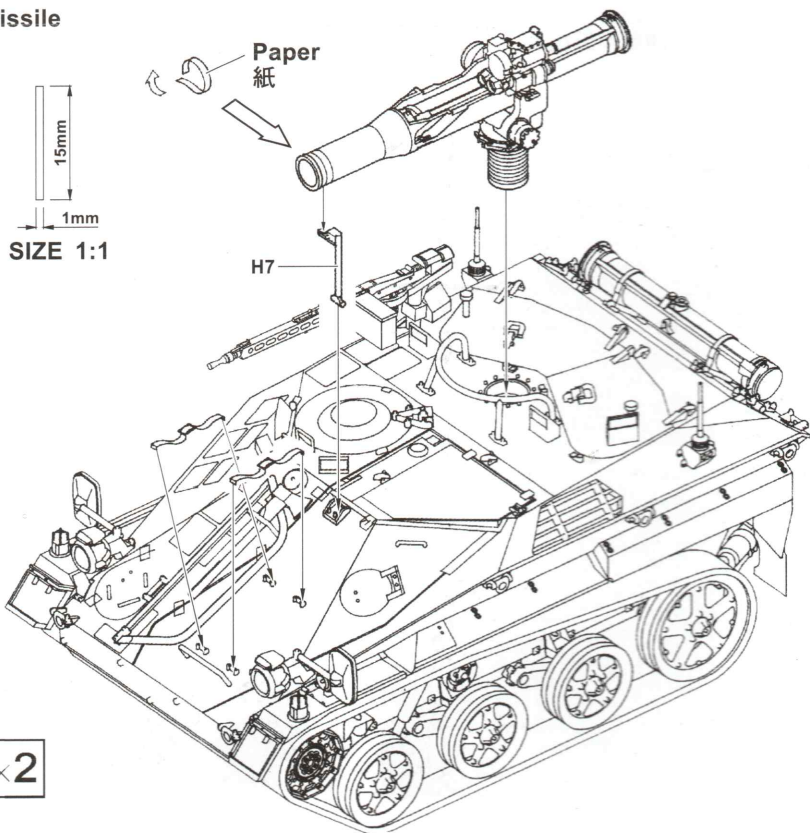
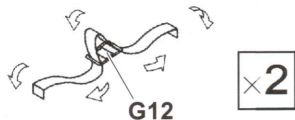

22

Wiesel 1 A2 TOW 鼬鼠拖式一型A2

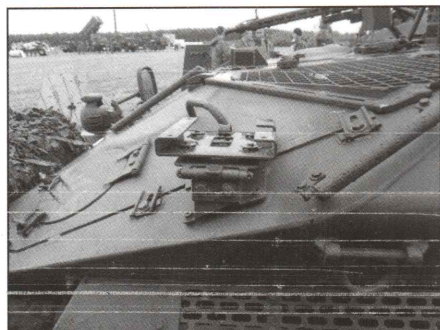
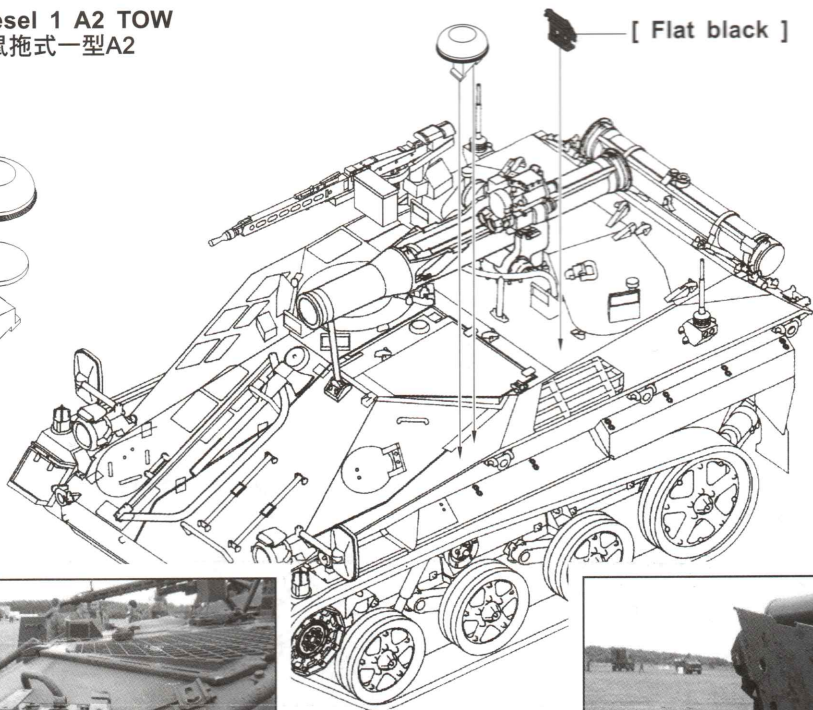
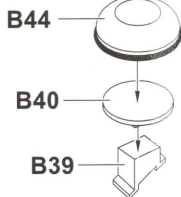

PARTS LIST 零件表

A X1

AF 35014



B X1

AF 35014

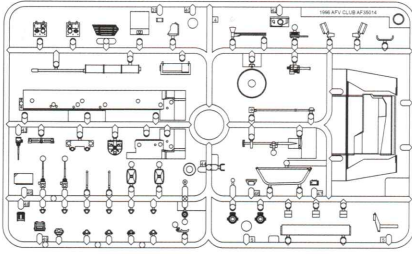

C X2

AF 35014

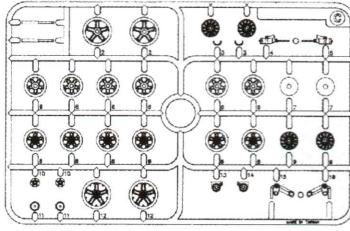

F X1

AF 35014



G X1

AF 35265



H X1

AF 35S33

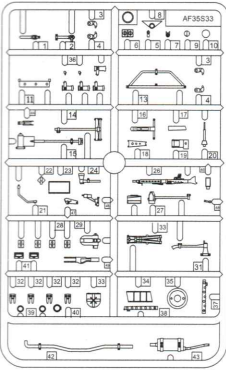

H X1

AF 35014

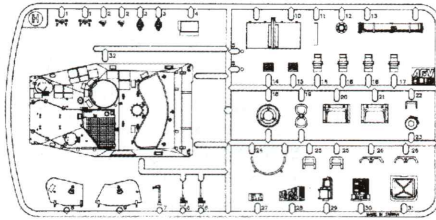

J X1

AF 35014

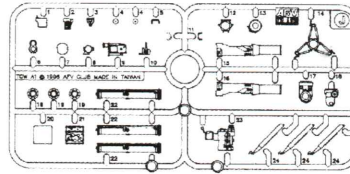

JA X1

AF 35265

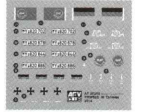

T X1

AF 35265

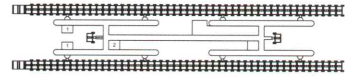

Instructions:

If for some reason, you are not fully satisfied or have questions concerning our product; Please use the form provide, and send it to our nearest representative or mail it directly to our office.

限臺灣地區使用 For Taiwanese use only!

總代理戰鷹企業有限公司收本公司將儘速為您處理。
請將本表與該部品相同金額之郵政匯票一同寄至



AF 35265 Parts Replacement Form

- | | |
|-------------------------------------|--------------------------------------|
| <input type="checkbox"/> AF 35014-A | <input type="checkbox"/> AH 35014-J |
| <input type="checkbox"/> AF 35014-B | <input type="checkbox"/> AF 35S33-H |
| <input type="checkbox"/> AF 35014-C | <input type="checkbox"/> AF 35265-G |
| <input type="checkbox"/> AF 35014-F | <input type="checkbox"/> AF 35265-JA |
| <input type="checkbox"/> AF 35014-H | <input type="checkbox"/> AF 35265-T |

Reason for replacement: Missing
 Broken

Signature: _____



AF 35265 零件補充申請表

申請人
姓名 地址 電話

- | | |
|--------------------------------------|----------|
| <input type="checkbox"/> AF 35014-A | NT\$ 125 |
| <input type="checkbox"/> AF 35014-B | NT\$ 160 |
| <input type="checkbox"/> AF 35014-C | NT\$ 150 |
| <input type="checkbox"/> AF 35014-F | NT\$ 70 |
| <input type="checkbox"/> AF 35014-H | NT\$ 160 |
| <input type="checkbox"/> AH 35014-J | NT\$ 140 |
| <input type="checkbox"/> AF 35S33-H | NT\$ 150 |
| <input type="checkbox"/> AF 35265-G | NT\$ 200 |
| <input type="checkbox"/> AF 35265-JA | NT\$ 160 |
| <input type="checkbox"/> AF 35265-T | NT\$ 280 |

+郵寄費 _____ NT\$ 80
(請填)總計NT\$ _____

零件補充原因:(請於打√)

原包裝即遺失或毀損,

製作途中遺失或毀損,

其他原因 _____



A **B** Wiesel 1 A1 TOW

Body Color: Bronze green Leather brown Tar black

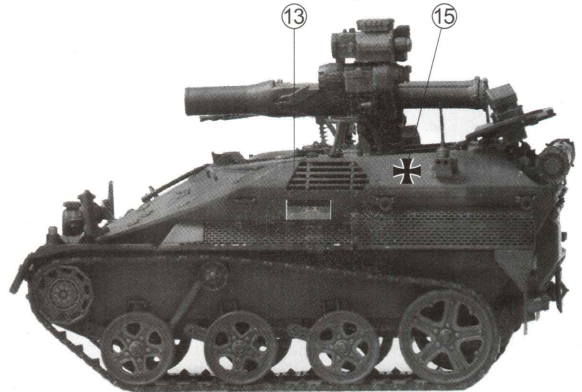
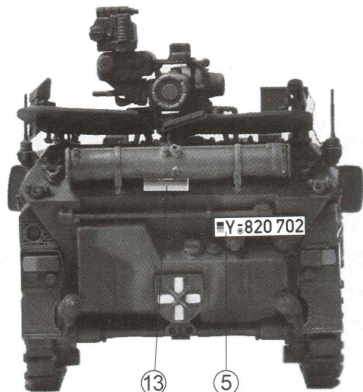
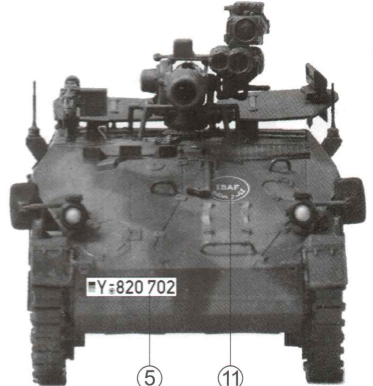
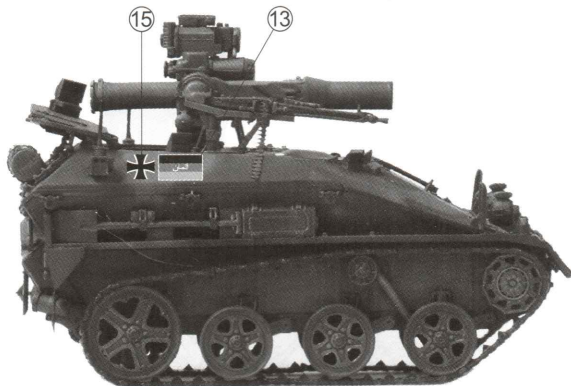
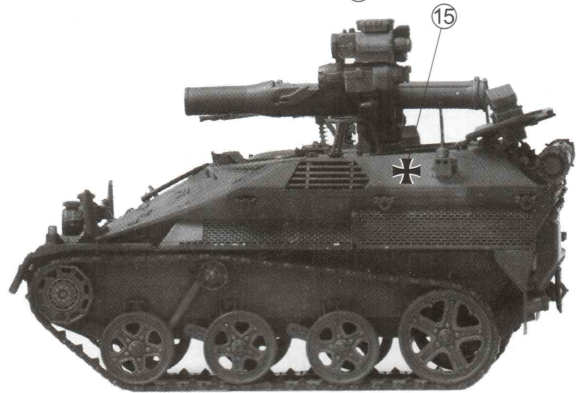
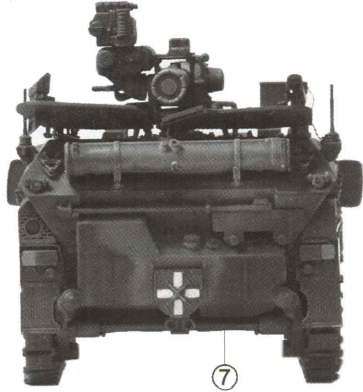
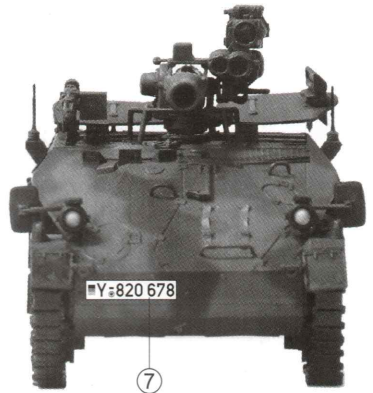
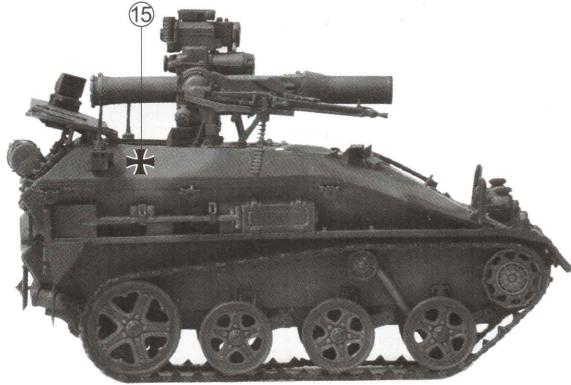

C Wiesel 1 A1 TOW

 Body Color: Bronze green 
Leather brown 
Tar black 

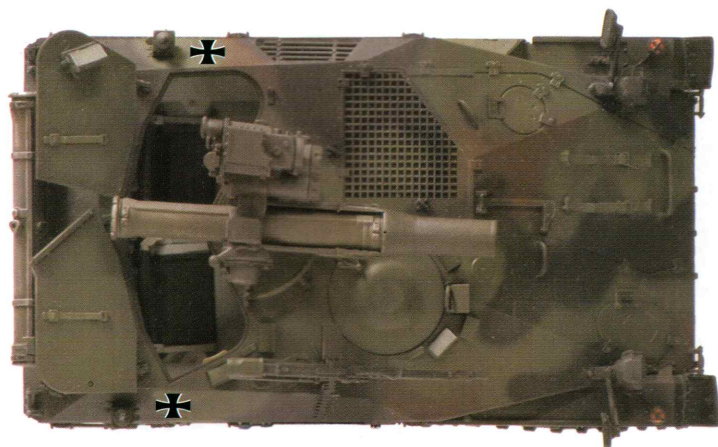
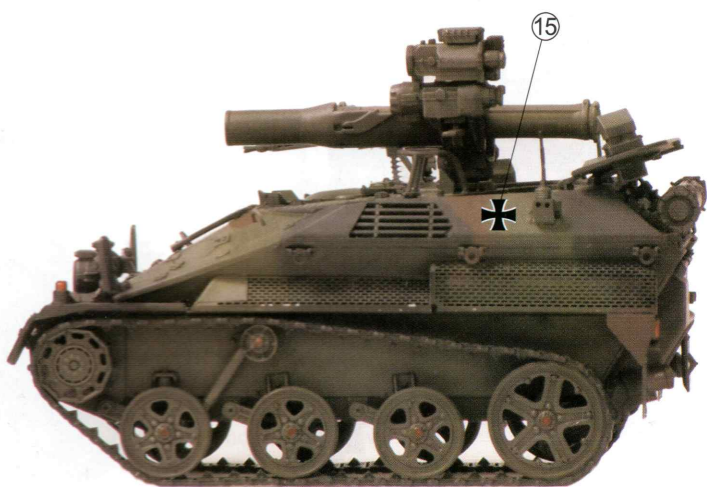
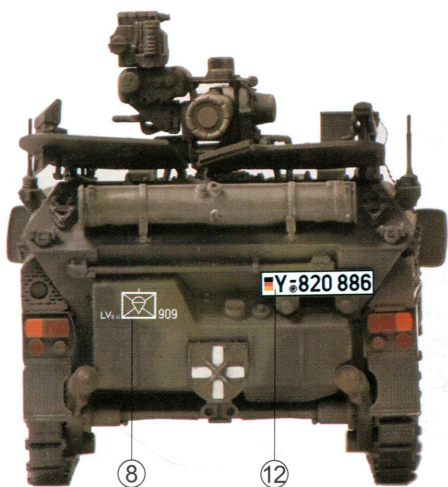
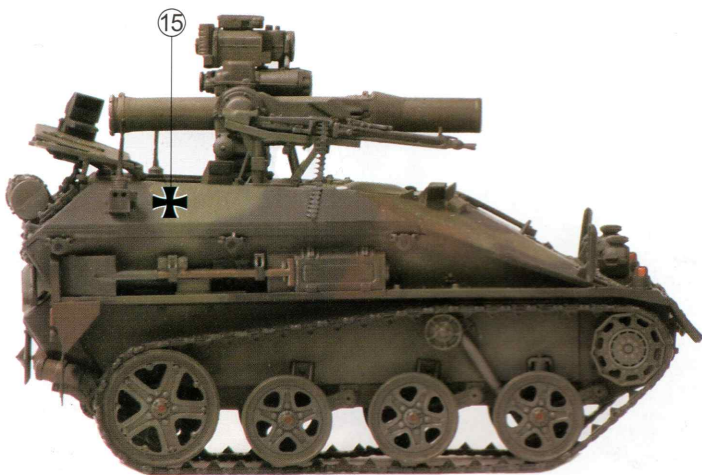

D Wiesel 1 A2 TOW



Body Color: Bronze green 
Leather brown 
Tar black 

