

Messerschmitt Bf 109E

MINISTRY of SMALL AIRCRAFT PRODUCTION

North Africa & the Med

Bf 109E-4B, with armoured wind-screen, of 7/SKG 210, El Daba, Autumn 1942. This aircraft retains the 71/02 colour scheme on wing and tailplane uppersurfaces, while fuselage top and sides are sand yellow (light) 79. The fuselage band and approx. 60 cm of the wingtips are white. Undersurfaces are probably light blue 65. The non-standard fuselage crosses are of particular interest.

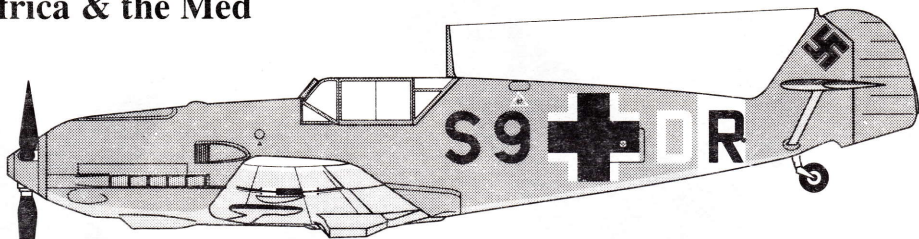

Bf 109E-4N/Trop of Gustav Rodel, II/JG 27, Libya, Summer 1941. Aircraft is finished with sand yellow (light) 79 uppersurfaces, and light blue 78 undersurfaces. Spinner and fuselage band are white, as are the wingtips.

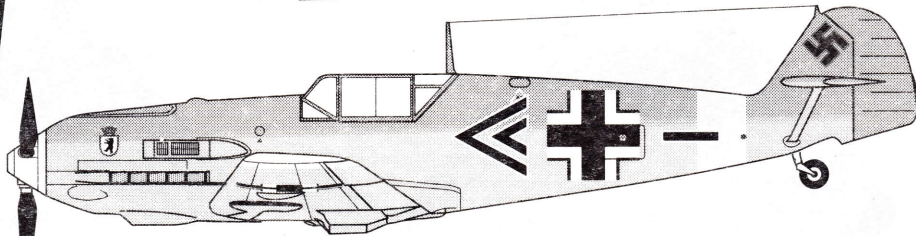

Bf 109E-4/N Trop Trop of I/JG 27, El Gazala, Summer 1941. Upper-surface of fuselage and flying surfaces is sand yellow (dark) 79 with green 80 blotches sprayed on. Undersurfaces and fuselage sides are light blue 78. Fuselage band is white, and spinner is black green 70 and white with a white cap.

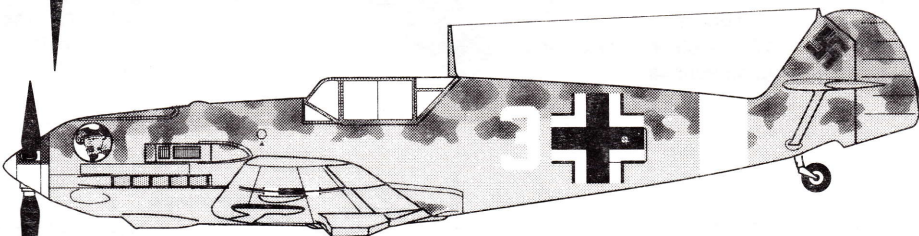

Bf 109E-4 Trop of Ludwig Franzisket, I/JG 27, April 1941. This aircraft is still in its European scheme of Greys 74 and 75 with undersurface and sides in 76. Spinner is black green 70 with a red tip; fuselage band is white.

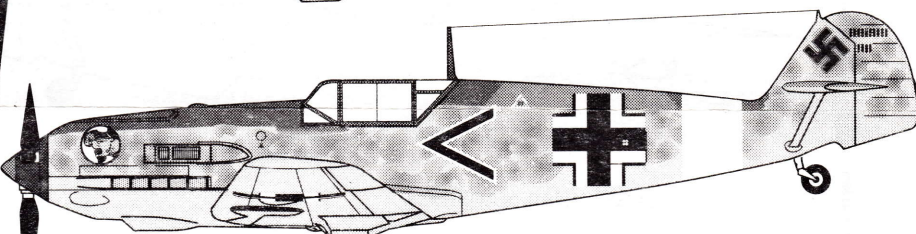

Bf 109E-4 Trop of I/JG 27, Libya 1941. Finish is basically the European scheme of greys 74 and 75, oversprayed with extensive mottling and stripes. Undersurfaces are light blue 76. Fuselage theater band is white, and spinner is red and white.

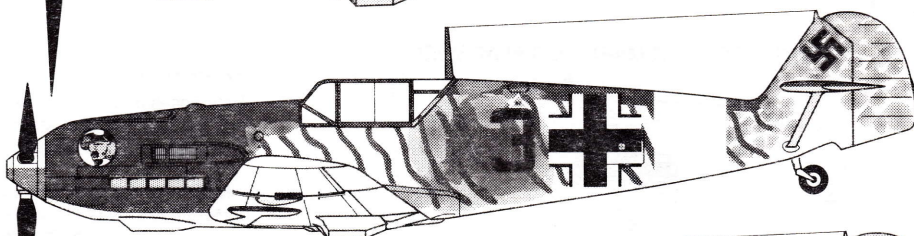

Bf 109E-7 of 7/JG 26. Flown by Joachim Müncheberg, Sicily 1941. Finish is RLM 74 and 75 with 76 undersurface and sides. Fuselage sides are mottled with the two darker colours. Nose and rudder are yellow 04. Spinner is white and black green 70. Note the white pennant on the antenna mast. *Schlageter* shield carried on left side only.

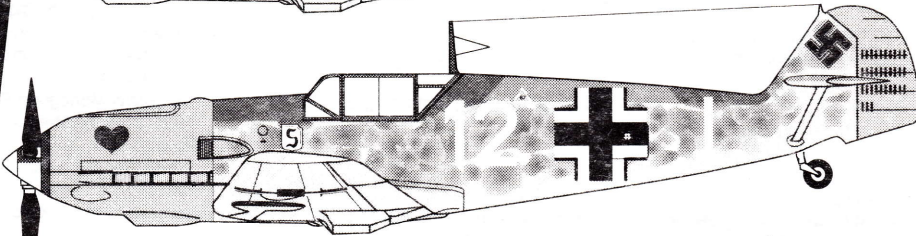

Bf 109E-4/B of III/JG 27, November 1941. Finish is standard European scheme of greys 74 and 75 with 76 sides and undersurface. Fuselage sides are mottled with the two greys. Rudder and cowling are yellow, while fuselage band, elevators, and approx. 60cm of wingtips, are white. Spinner is black green 70.

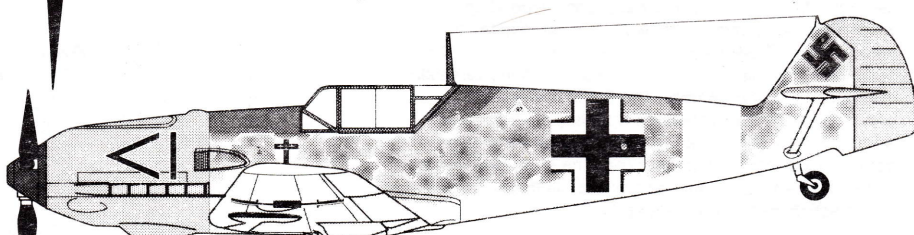

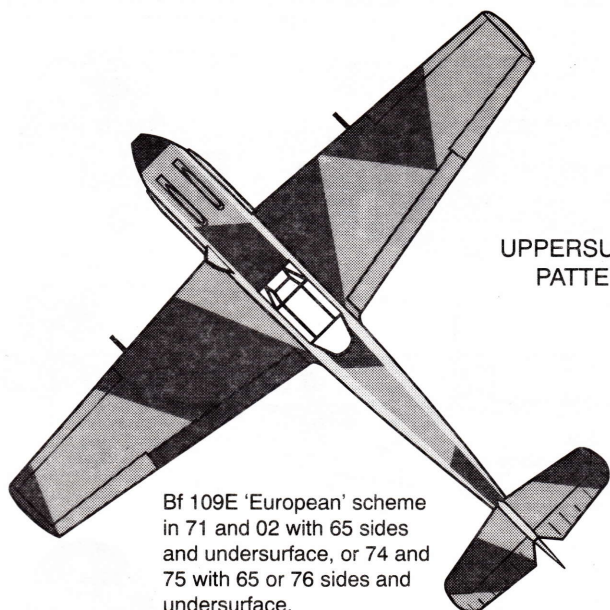

Bf 109E 'European' scheme in 71 and 02 with 65 sides and undersurface, or 74 and 75 with 65 or 76 sides and undersurface.

UPPERSURFACE PATTERNS

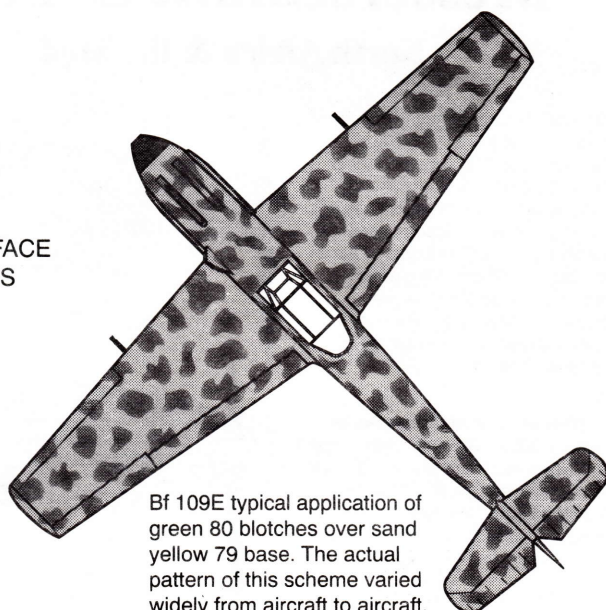

Bf 109E typical application of green 80 blotches over sand yellow 79 base. The actual pattern of this scheme varied widely from aircraft to aircraft.

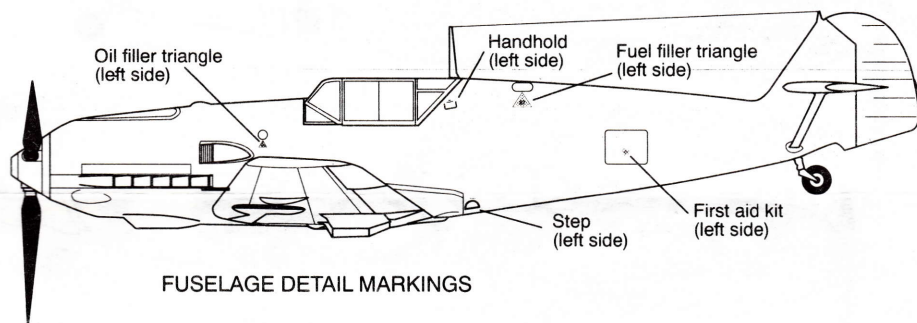

FUSELAGE DETAIL MARKINGS

STANDARD WING MARKINGS PLACEMENT

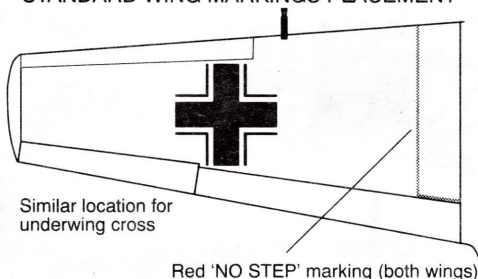

KITS

At present the suggested kits to use for the Bf 109E are the Minicraft, Matchbox and Heller versions. Depending on which kit is used, some minor work may be required to depict an E-4 /B version with its fuselage mounted ETC 500 bomb rack. The Matchbox kit provides an optional air intake filter to use on *Trop* versions. The E-7 is basically an E-4 with a centreline rack capability. Spinners on the E-7 version were usually of the pointed type. E-4 aircraft were also occasionally fitted with a spinner cap. The best reference for these structural variations and mods is "Messerschmitt Bf 109 in Action, part 1" from Squadron/Signal.

REFERENCES

References on the Bf 109 and its sundry camouflage schemes and markings abound. Among those most useful for building and finishing the aircraft on this decal sheet are the following:

- Messerschmitt Bf 109 in Action (Squadron/Signal #44)
- Messerschmitt Bf 109 Into the Battle, by Michael Payne
- Augsburg Eagle, the Messerschmitt Bf 109, by William Green
- German Aircraft Markings 1939-1945, by K.A. Merrick
- The Modeller's Luftwaffe Painting Guide, by Smith, Pentland, & Lutz
- The Official Monogram Painting Guide to German Aircraft 1935-1945, by Merrick & Hitchcock
- Markings and Camouflage Systems of Luftwaffe Aircraft in World War II, by Karl Ries
- Planes of the Luftwaffe Fighter Aces, vols 1 & 2, by B. Barbas
- Various issues of Scale Aircraft Modelling

Available in MSAP's 1/72 109E series:

- 7201 - Battles of Poland and France
- 7202 - Battle of Britain
- 7203 - North Africa & the Med
- 7204 - Russian campaign

MINISTRY of SMALL AIRCRAFT PRODUCTION

Box 94, Stn. A Hull, Quebec J8Y 6M7 Canada
Fax: (819) 771-8996