

# 涂装同标贴指示

## Painting & Marking guide

**A**

PAINT REFERENCE COLOUR

Color	Mr.Hobby	Vallejo	Model Master	Tamiya	Humbrol
Dark Green 深绿色	H 309 309	893	1710	XF58	116
Steel (Metal Black) 黑铁色	H 18 28	864	1402	-	-
Tire Black 胎黑色	H 77 137	-	-	-	-
White 白色	H 1 1	842	1745	X2	22

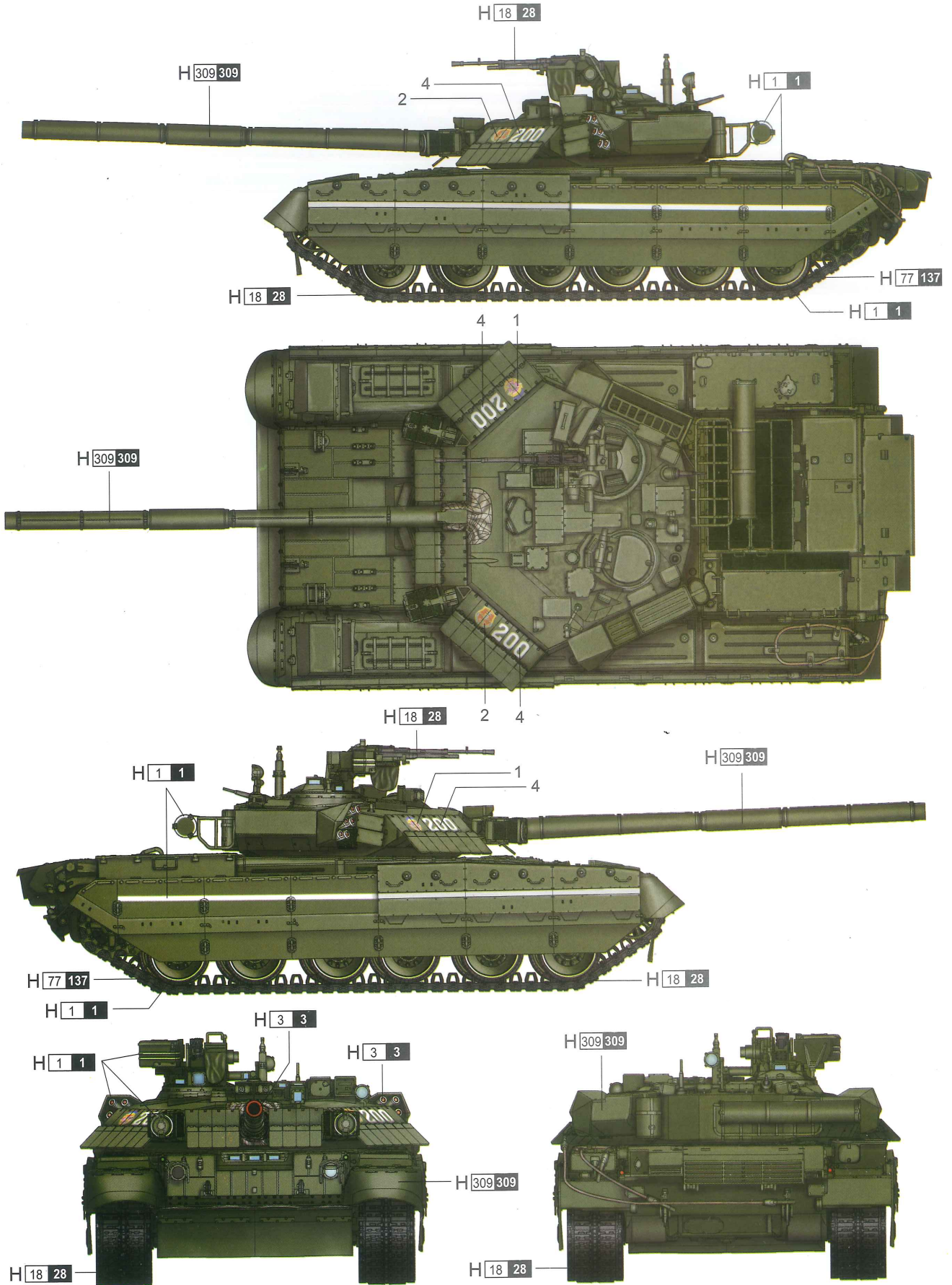

H  AQUEOUS HOBBY COLOR     Mr. COLOR

# 涂装同标贴指示

## Painting & Marking guide

PAINT REFERENCE COLOUR					
Color	Mr.Hobby	Vallejo	Model Master	Tamiya	Humbrol
Sandy Brown 砂黄色	H 79 39	824	—	XF59	93
Light Green 绿色	H 303 303	—	1713	XF20	117
Flat black 消光黑	H 12 33	950	1749	XF1	33
Red 红色	H 3 3	908	1503	X7	19

**B**

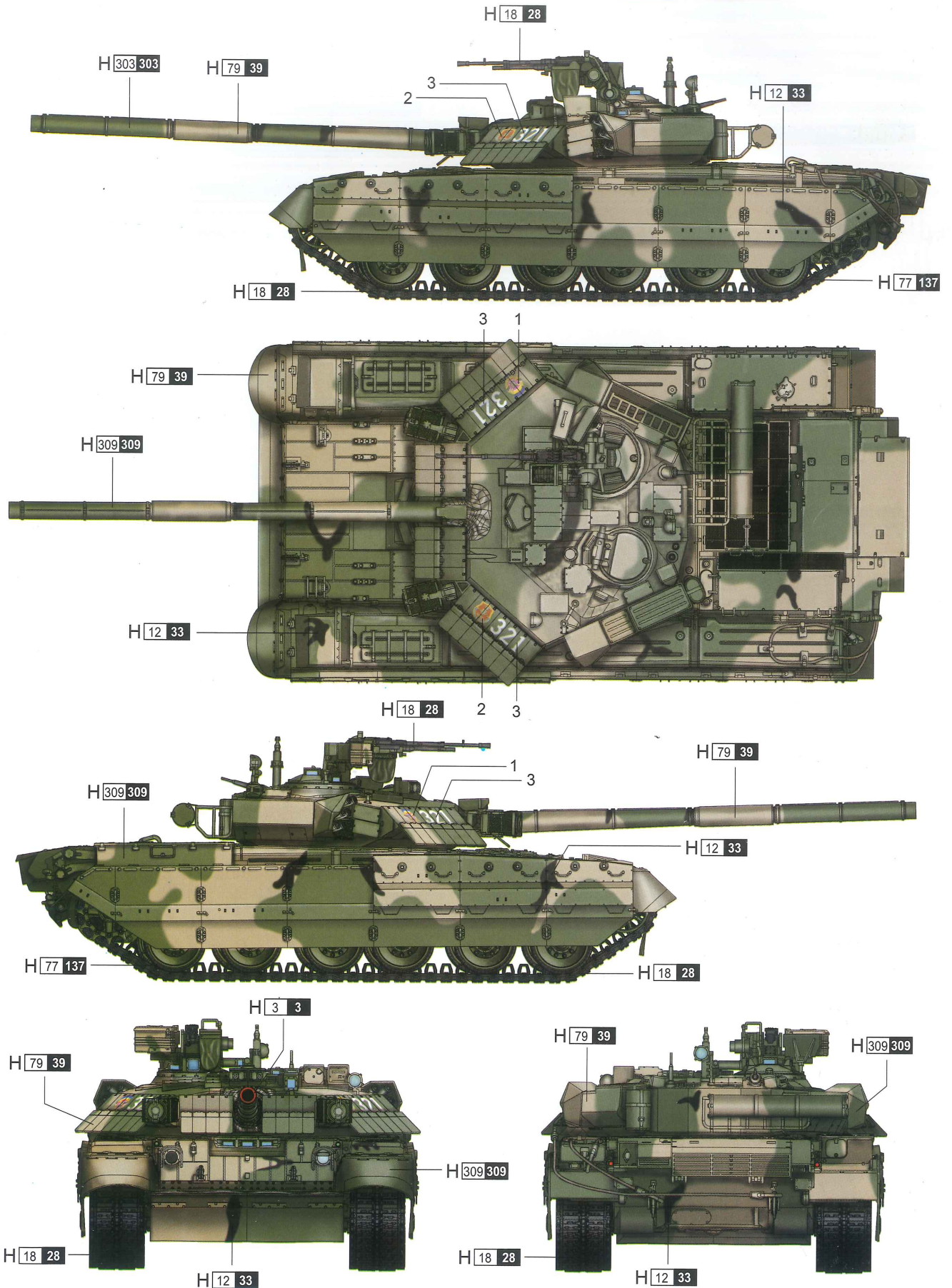

H  AQUEOUS HOBBY COLOR     Mr. COLOR



## Ukrainian T-84 MBT

### 乌克兰T-84主战坦克

#### READ BEFORE ASSEMBLY:

- Study and understand these instructions thoroughly before beginning assembly
- When needed, remove photo-etch parts carefully using a modeling knife or photo etch sprue cutter, being careful not to damage or lose small parts.
- Take extra care in handling photo etch parts in order to avoid injury
- Apply instant cement sparingly to photo etch parts where instructed
- Tools recommended(not included in kit):Plastic and instant cements, sprue cutters,long nose pliers,modeling knife, small files, tweezers, pin vise & scissors. Soft cloth and sandpaper will also assist in construction
- Glue and paint are not included in the kit. Use plastic cement and hobby paints only. Color guide for purchasing paint is included in the kit.

#### 装配之前仔细阅读

- 小心用模型锉刀锉平所有零件表面的注射浇口。
- 小心用刀片切下蚀刻片零件，不要遗失小零件。
- 用强力快干胶水粘合蚀刻片零件和金属轴。过量快干胶水使用可能导致可动零件会粘住，小心涂胶。
- 取蚀刻片时应特别注意安全，防止利边划伤手指。
- 某些零件表面需贴水上贴纸，请选择在装配的同时进行。
- 推荐模型工具(自备)：胶水，水口剪刀，长咀钳，刀片，锉刀，镊子，钳，钻，剪刀，瞬间快干胶。
- 软布同砂纸同时也应该是必备工具。
- 请使用塑料胶水和油漆，模型内不含。



配重  
Weight



使用强力胶  
Cyanoacrylate glue



钻孔  
Make hole



切除  
Cut / Remove



贴纸  
Decal



锉平  
File / Sand



选择  
Option



不涂胶水  
No cement



弯曲  
Bend



先装  
Install it first

#### 水贴纸的使用:

- 1.从水贴纸上剪下印花;
- 2.将印花放入温水中浸10秒,然后放在干净布上。
- 3.拿着印花纸板将印花移到模型上;
- 4.手指蘸水将印花移到适当的位置;
- 5.用软布轻压印花直至水干, 汽泡消失

#### DECAL APPLICATION

- 1.Cut decals from sheet as needed
- 2.Dip the decal in warm water for about 10 seconds and then place on soft clean cloth.
- 3.Hold the decal backing sheet edge and gently slide the decal onto the model in its proper position.

- 4.While still wet,decal can be adjusted for better fit on model by dampening it gently with your finger.
- 5.When placed in the proper position,gently press decal down with a soft cloth until excess water and air bubbles are gone.
- 6.Allow decal to dry completely before handling model

部品图  
Parts

A×4

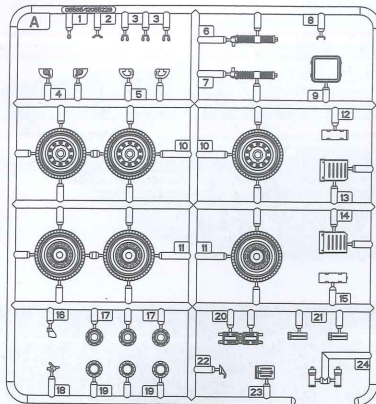

C×4

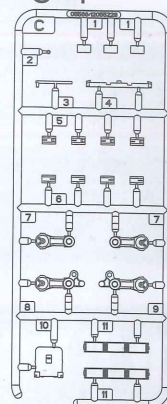

D×2

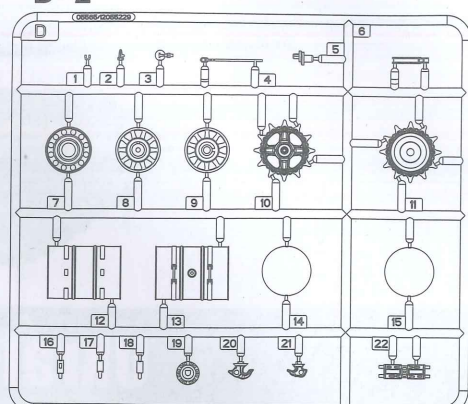

E×2

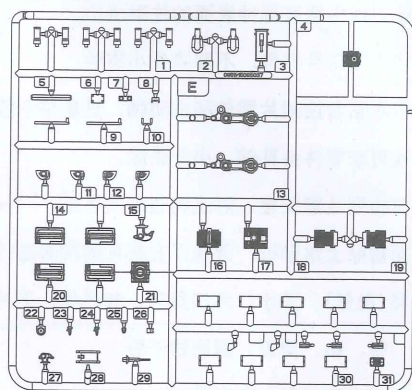

G×2

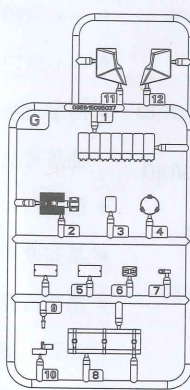

P

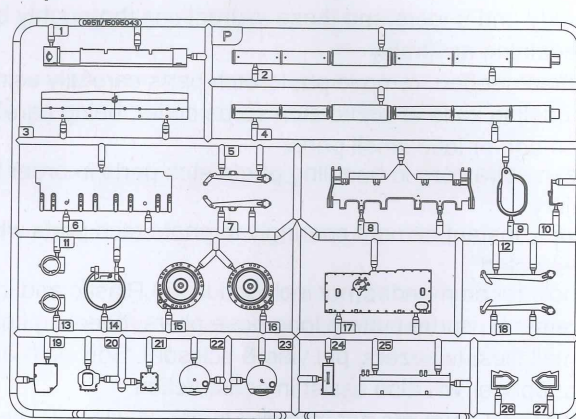

Q

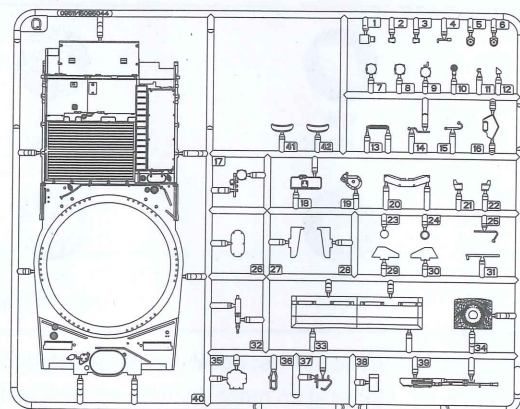

H

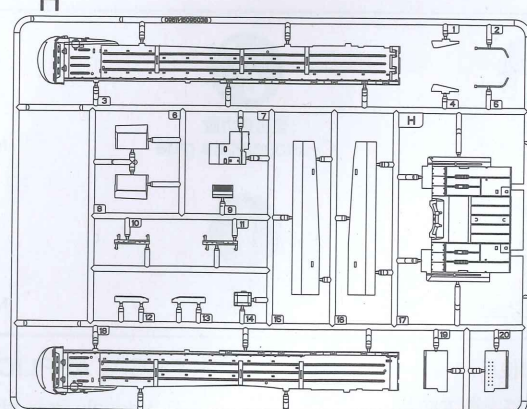

部品图  
Parts

J

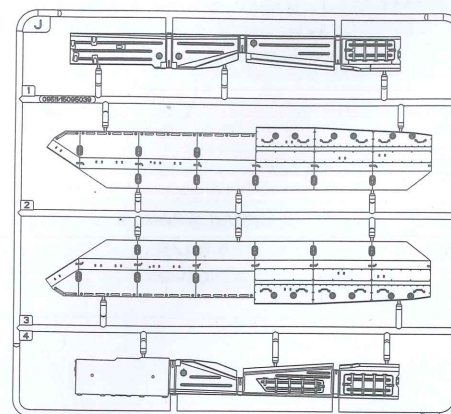

K

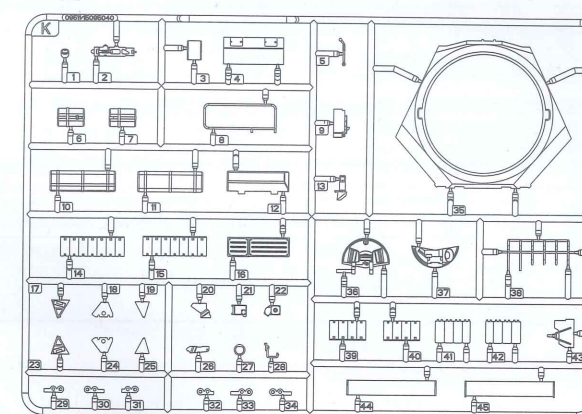

T×4

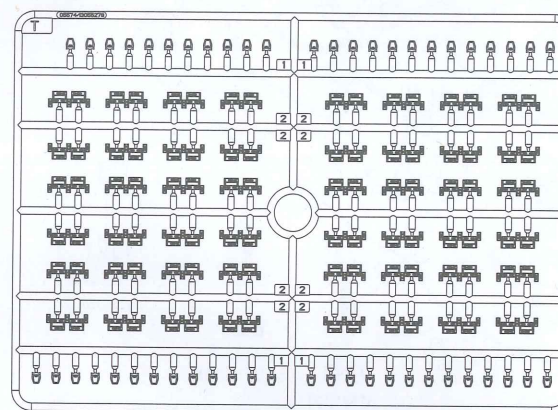

《蚀刻片》  
PE

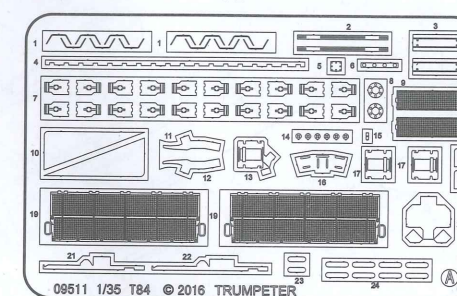

N

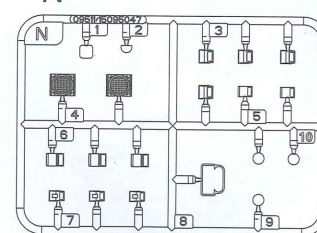

《炮塔》  
Turret

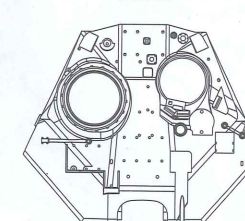

《铜线》φ 0.8×180mm  
Brass wire



《车底》  
Lower hull

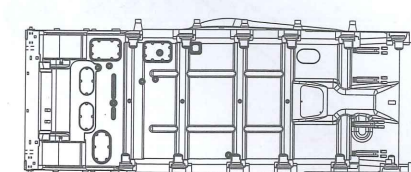

《水贴纸》  
Decal



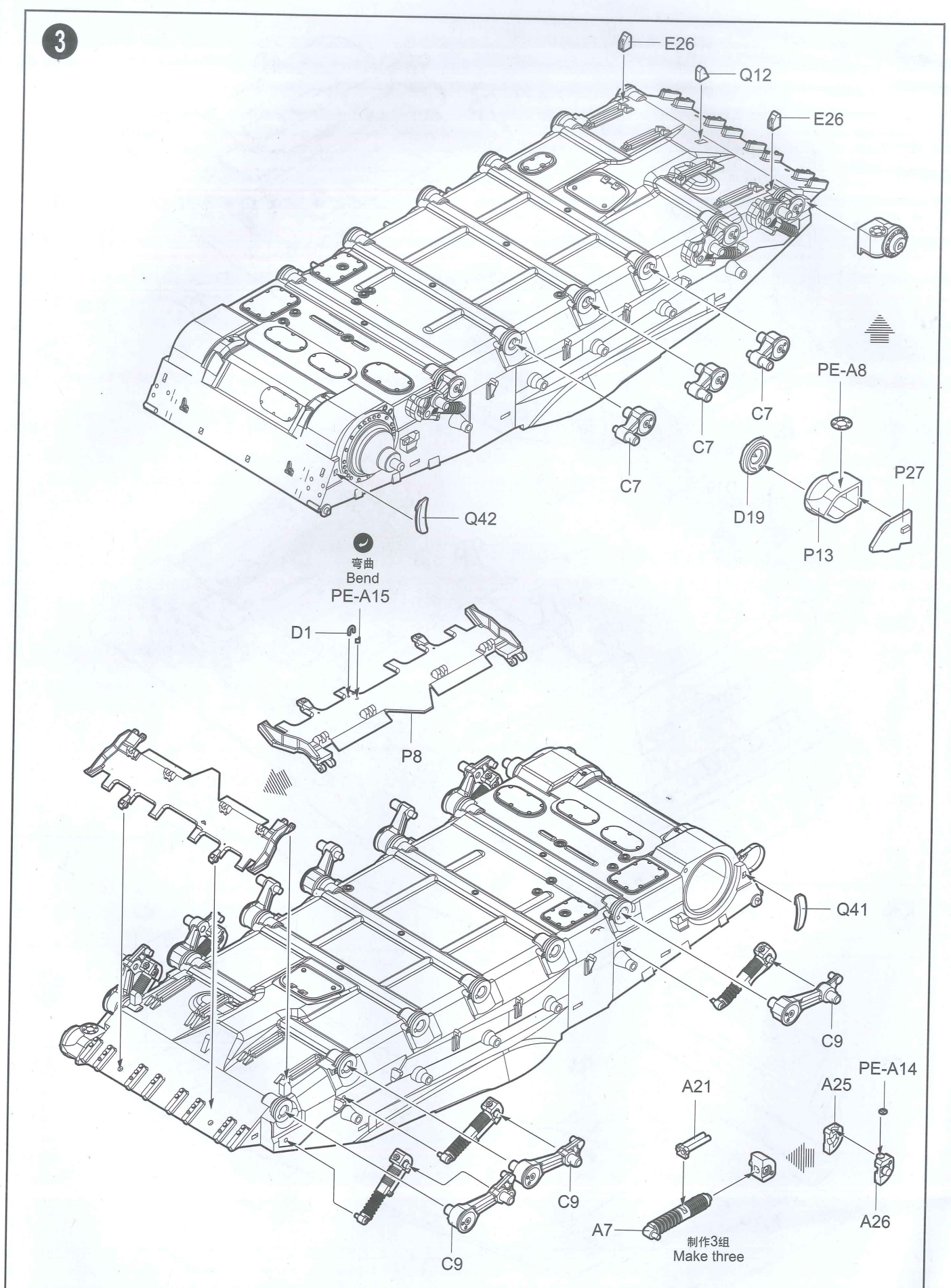
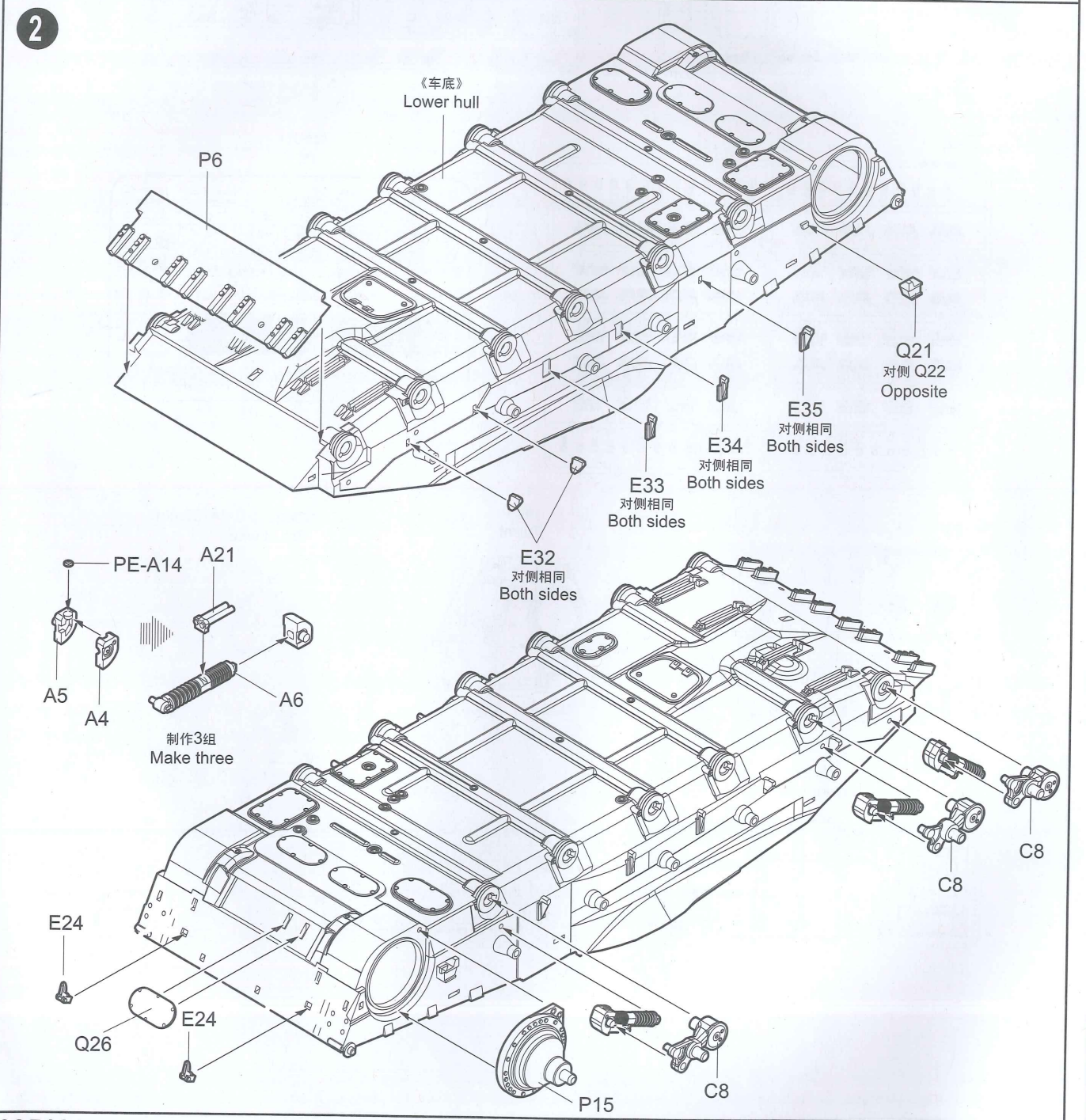
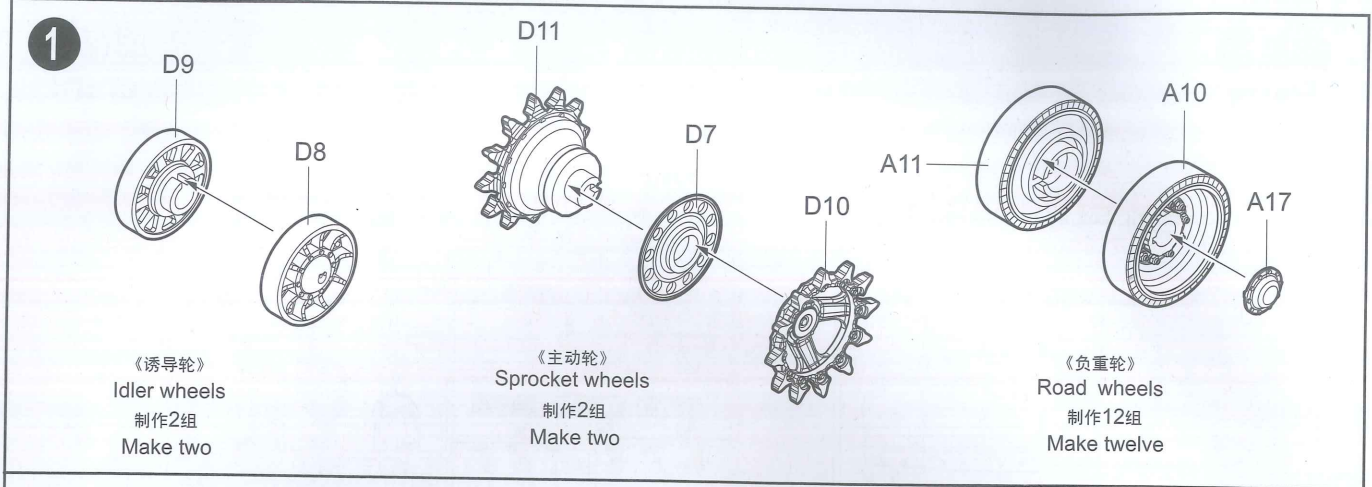

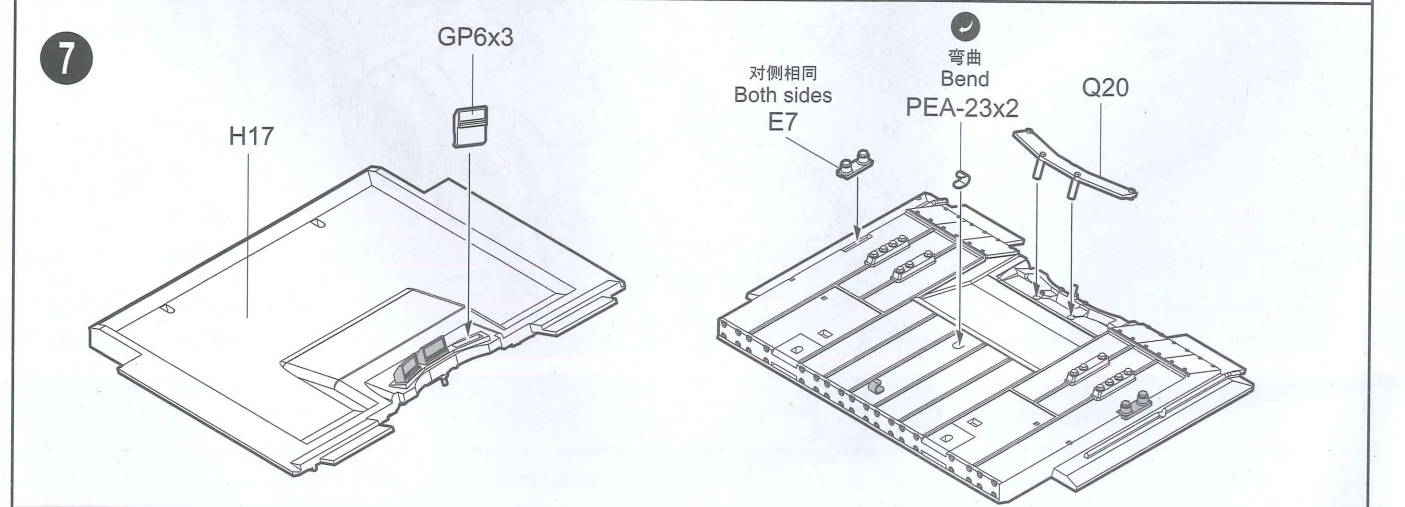
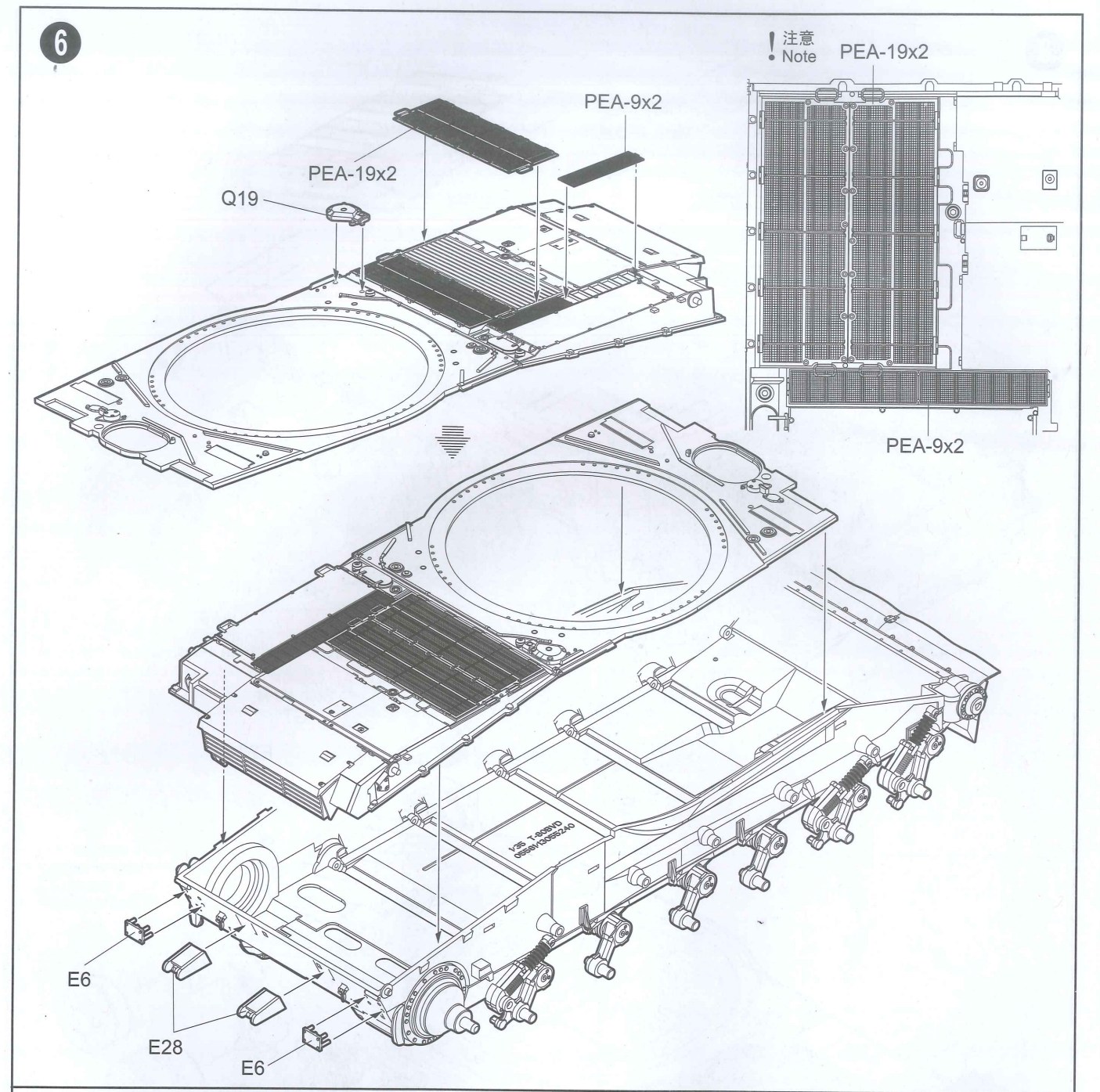
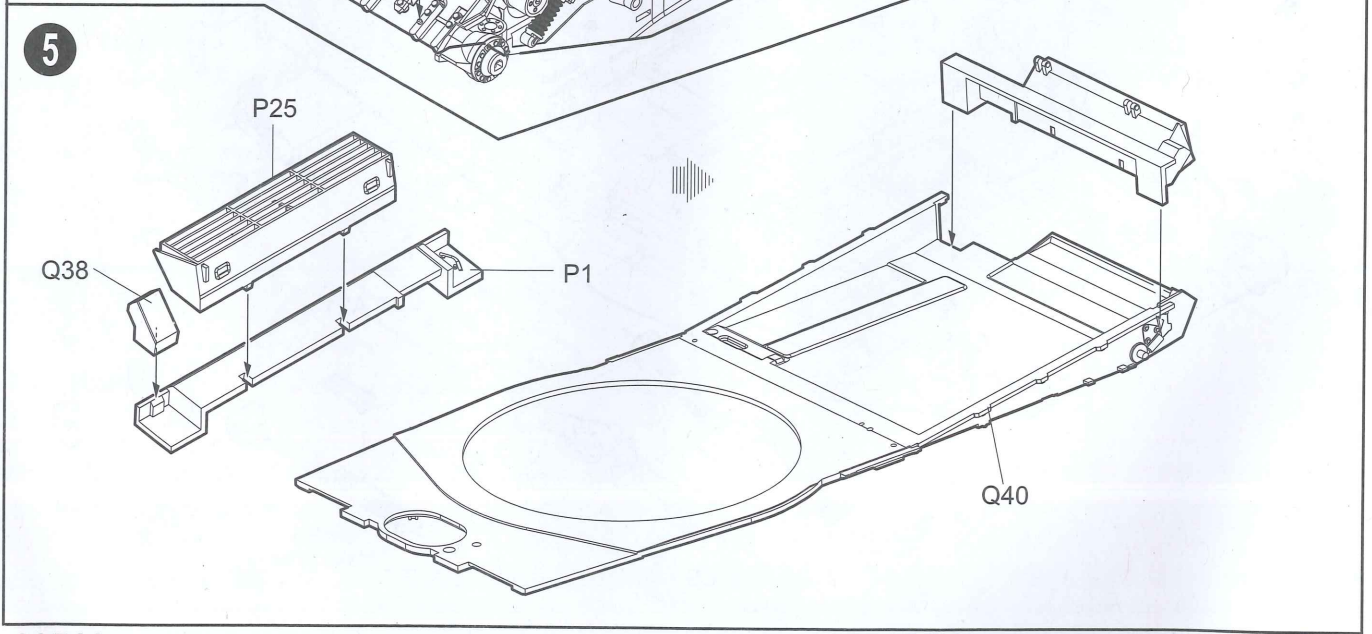
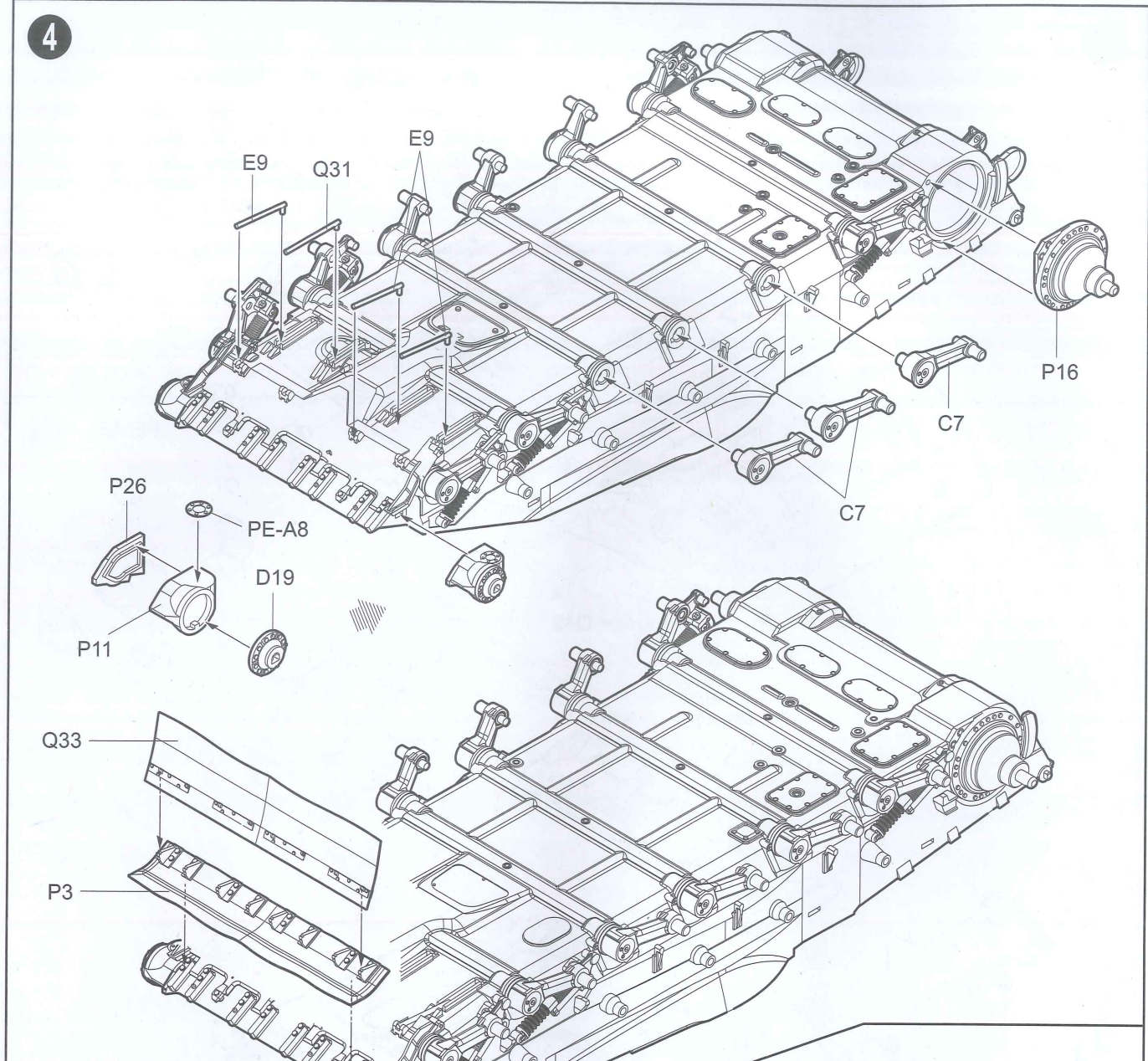

8

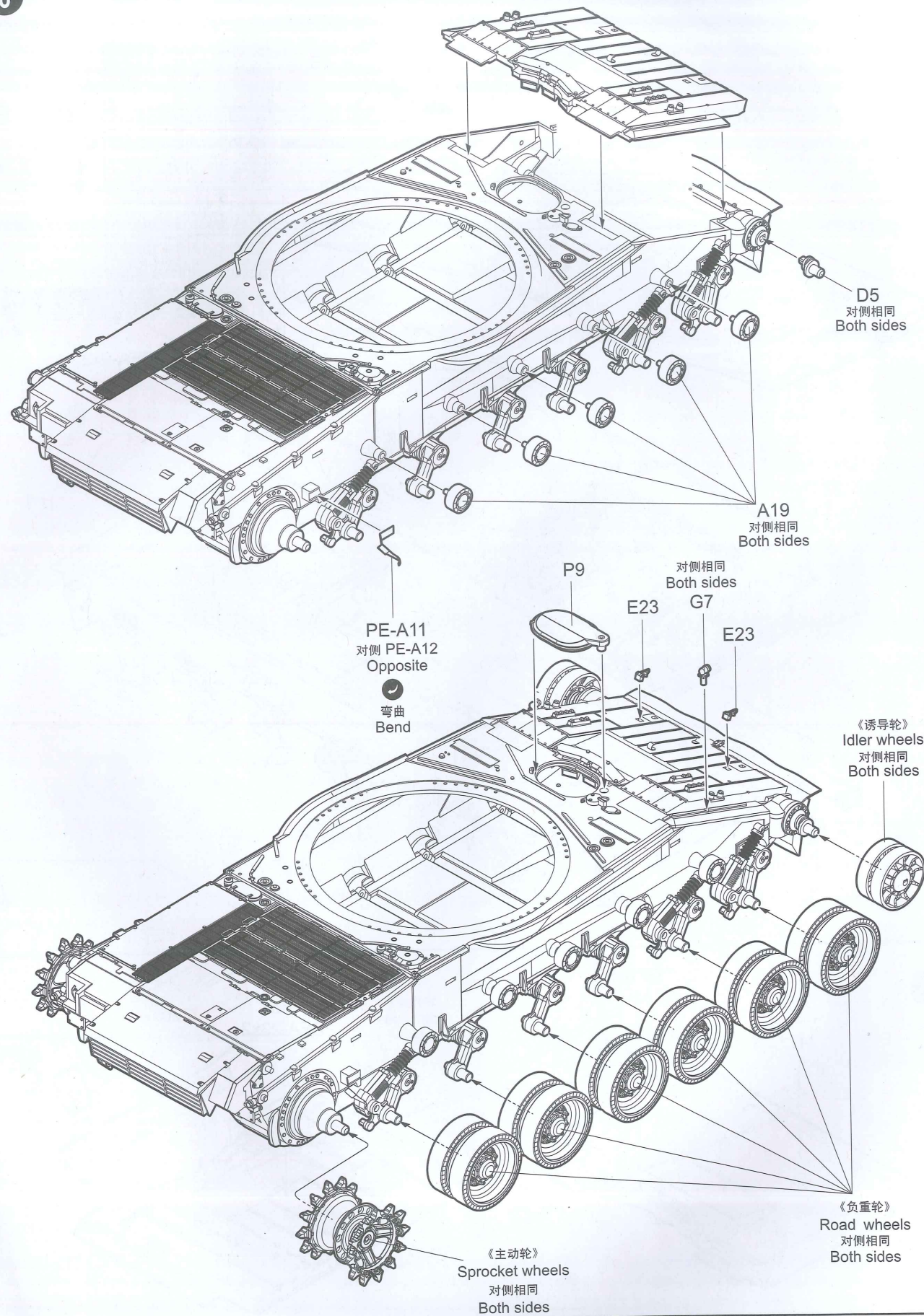

09511

8

9

单侧履带需要80节  
Complete track for one side require 80 links.

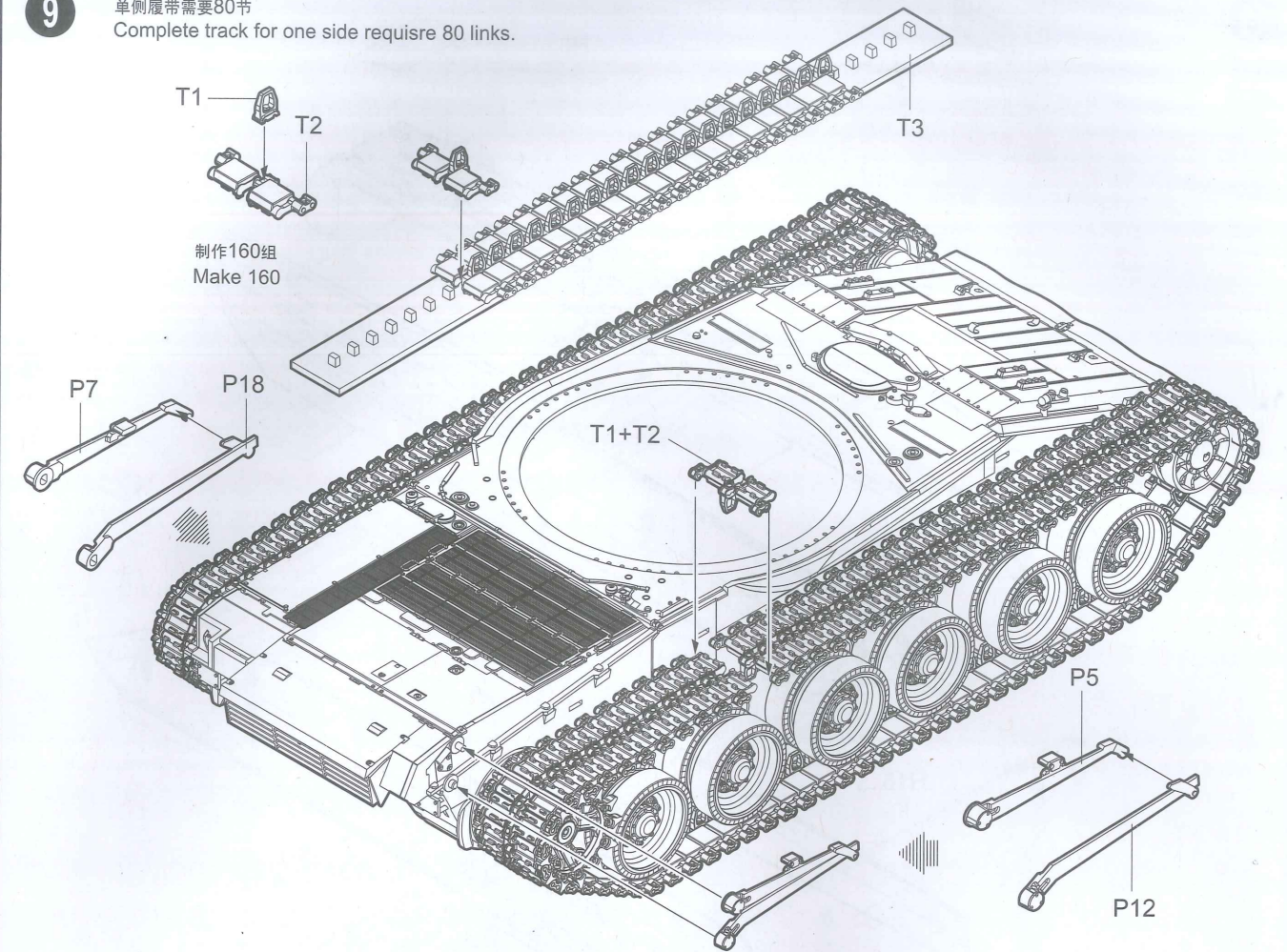

10

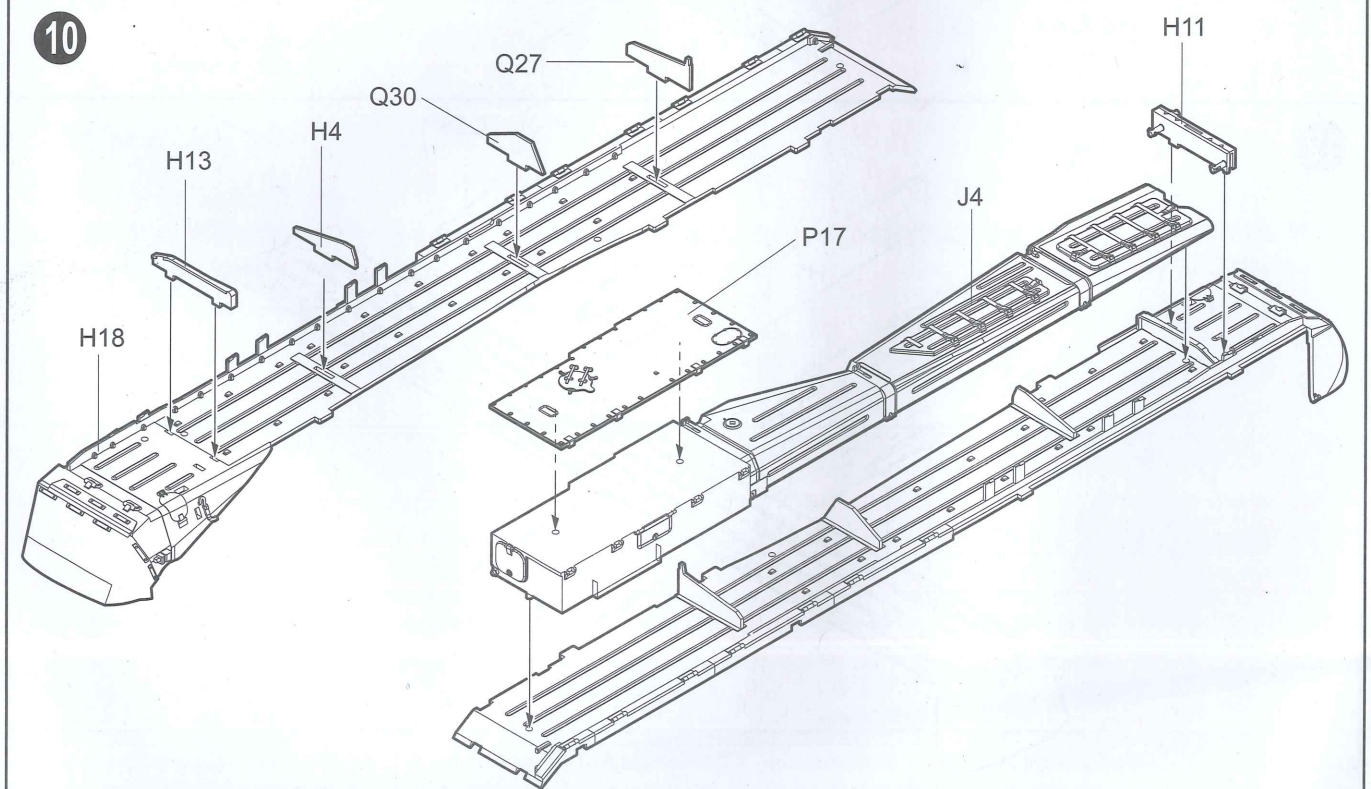

09511

9

11

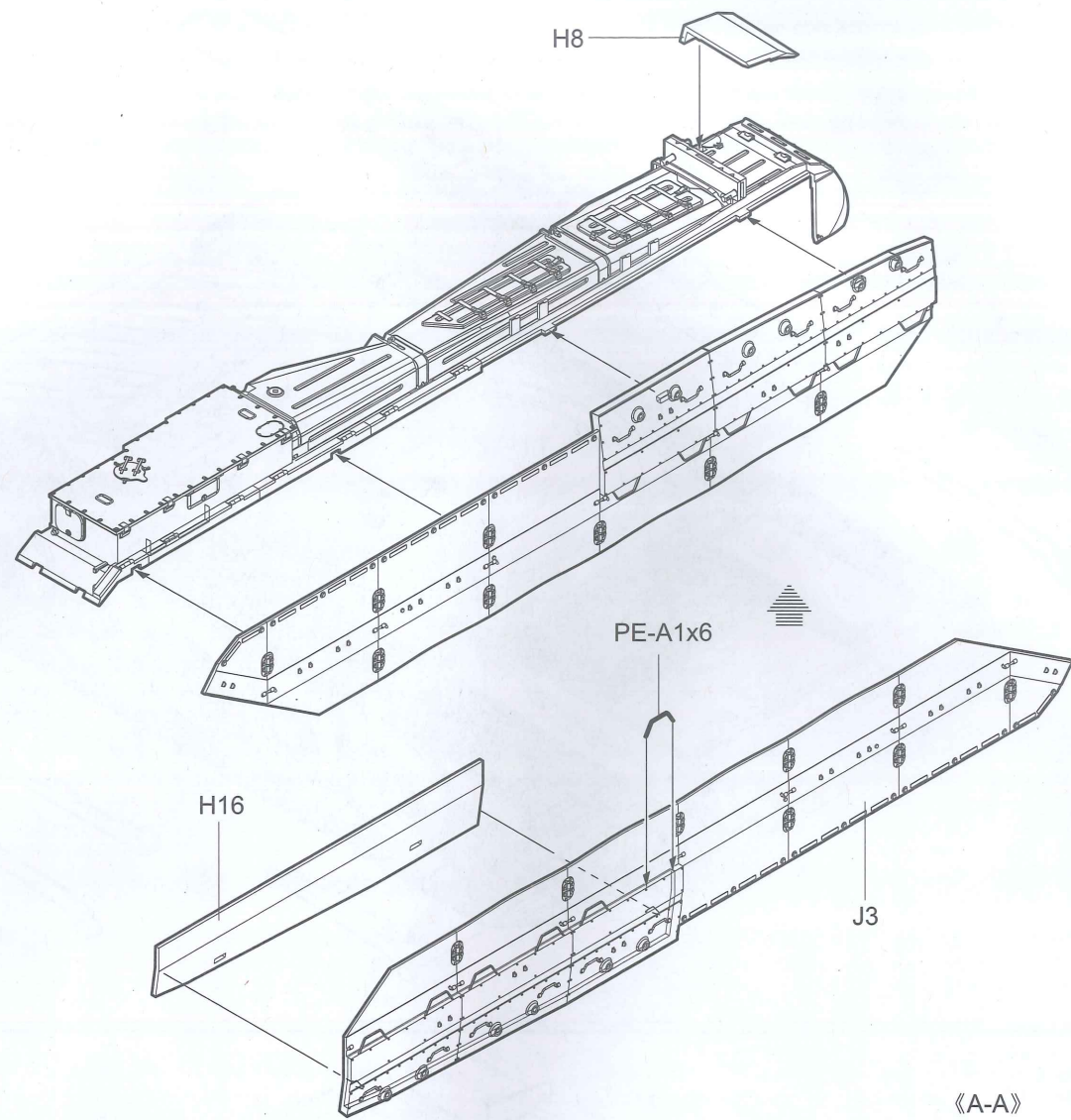

«A-A»

12

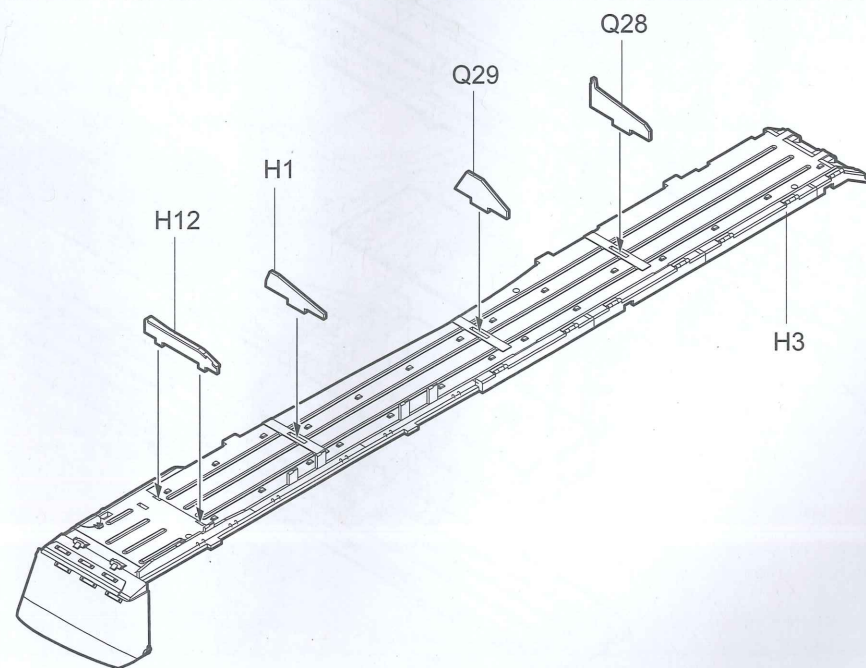

13

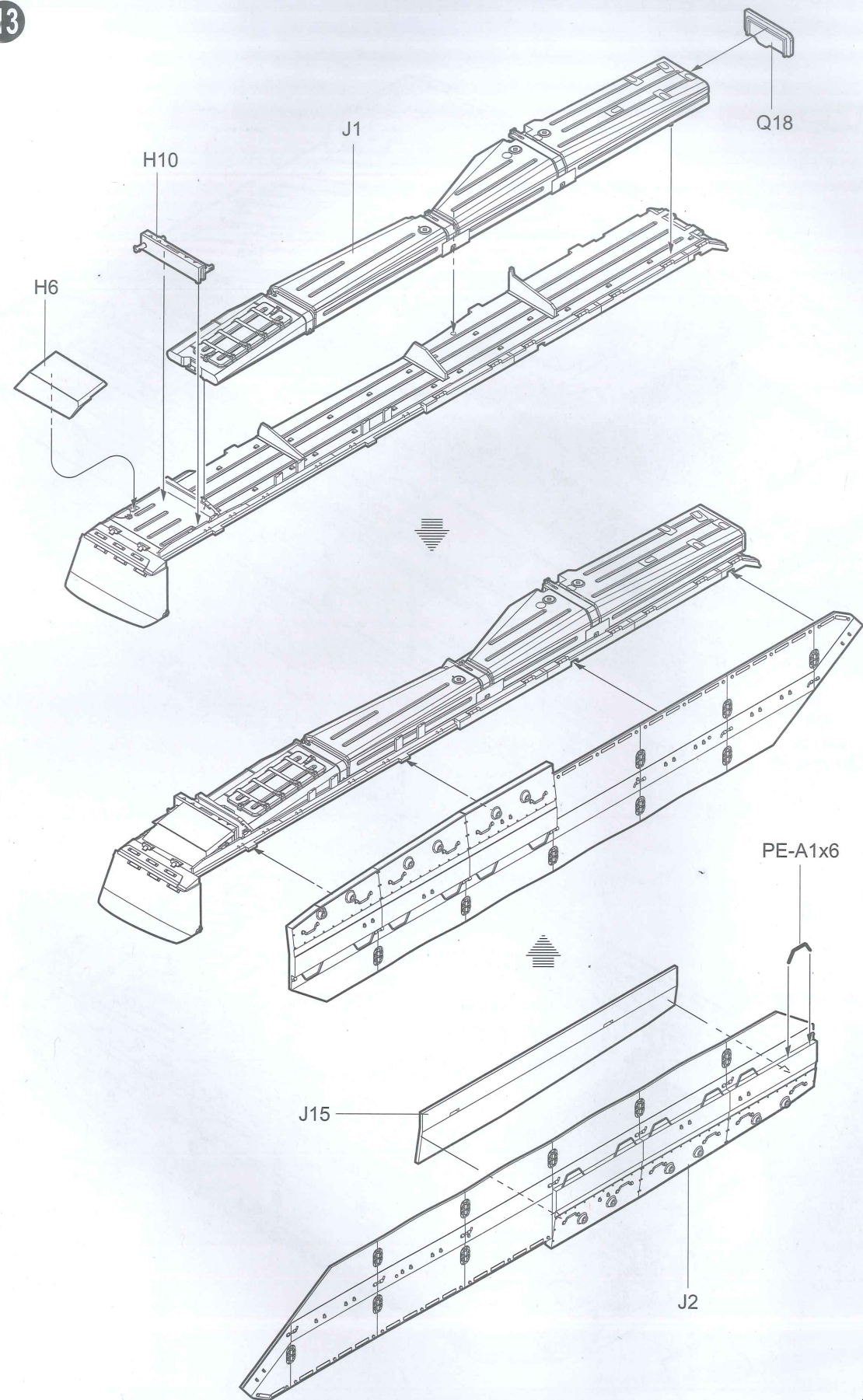

«B-B»



14

弯曲  
Bend  
PE-A24x5

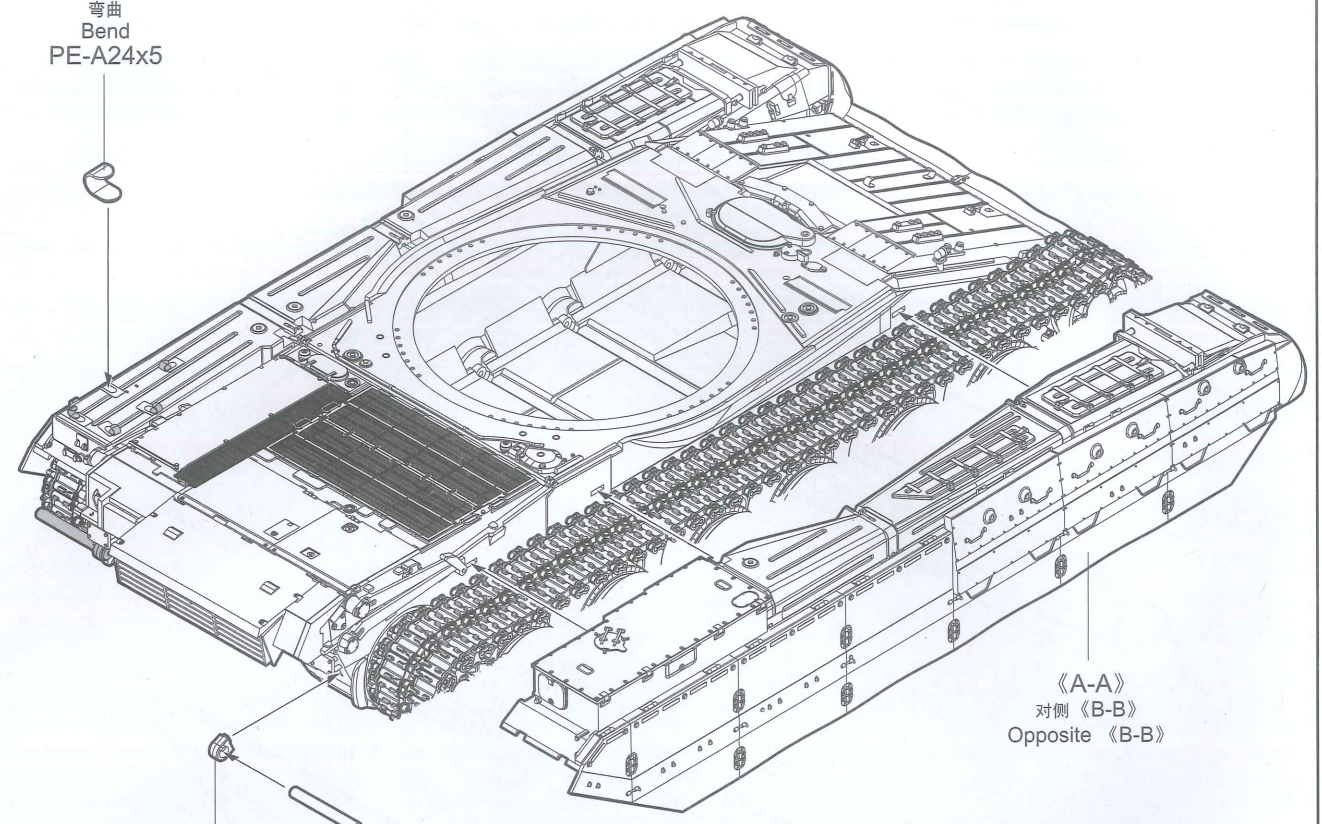

Q6  
对侧 Q5  
Opposite Q5

E5  
对侧相同  
Both sides

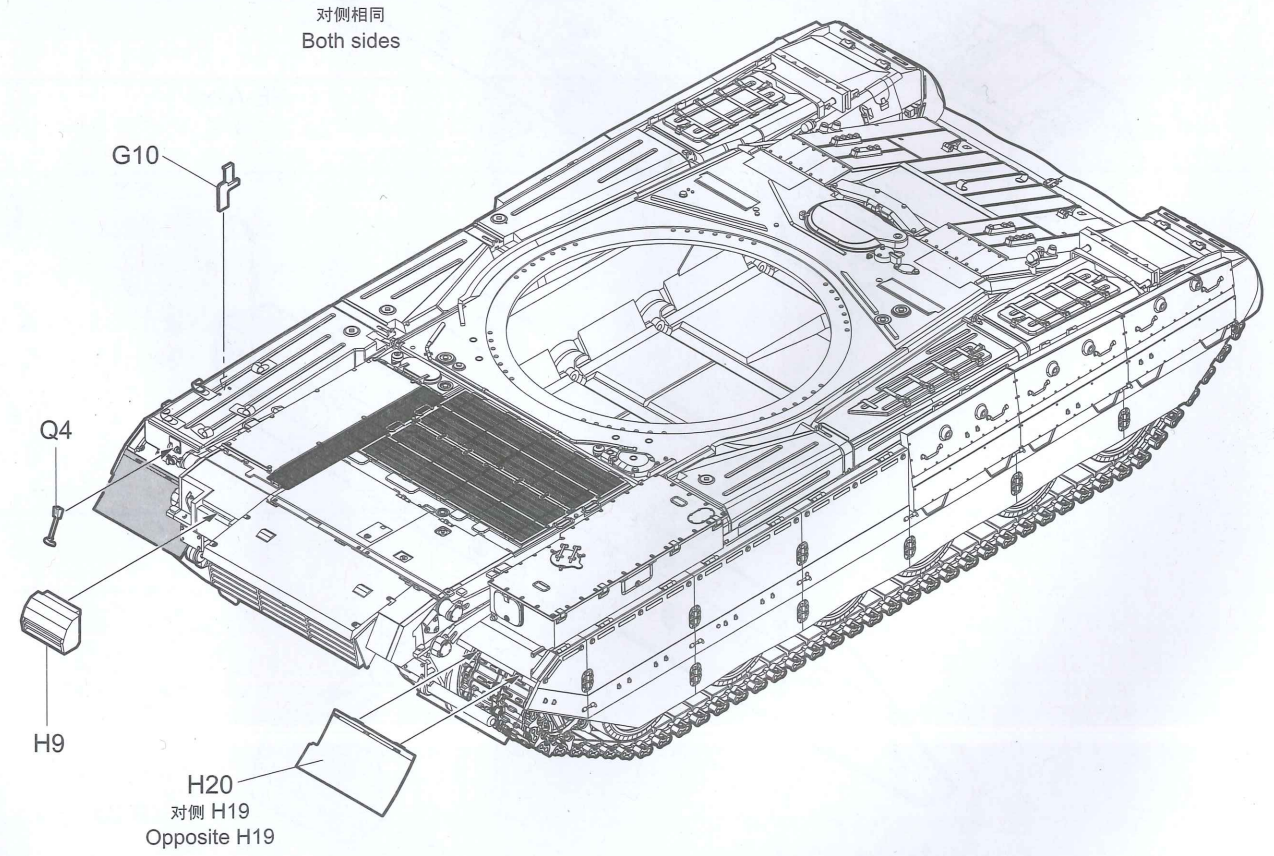

15

E2 ——— E2

《铜缆》 Ø0.8×80mm  
Brass wire  
制作2组  
Make two

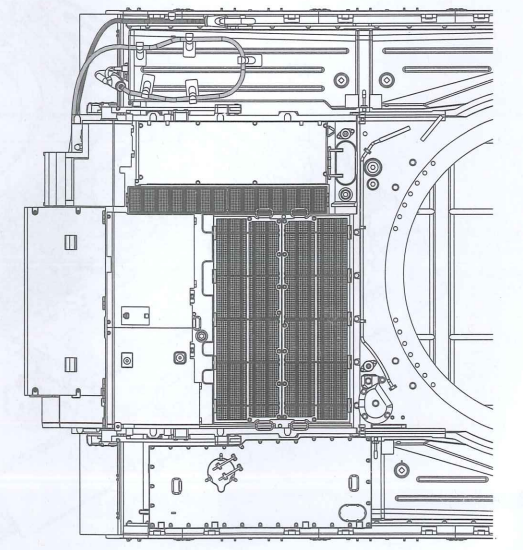
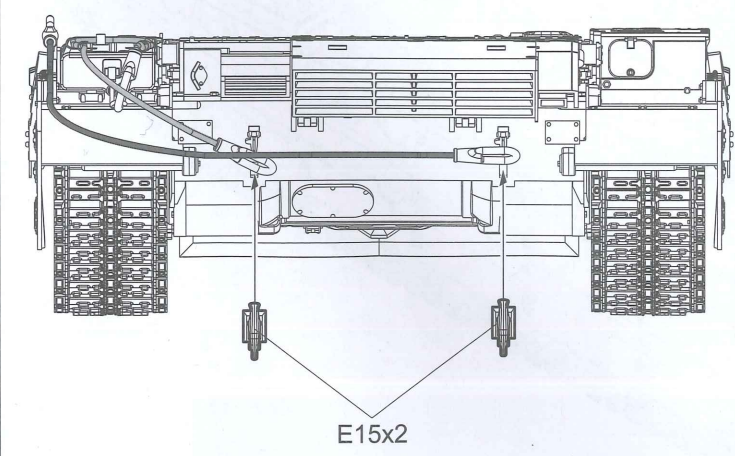
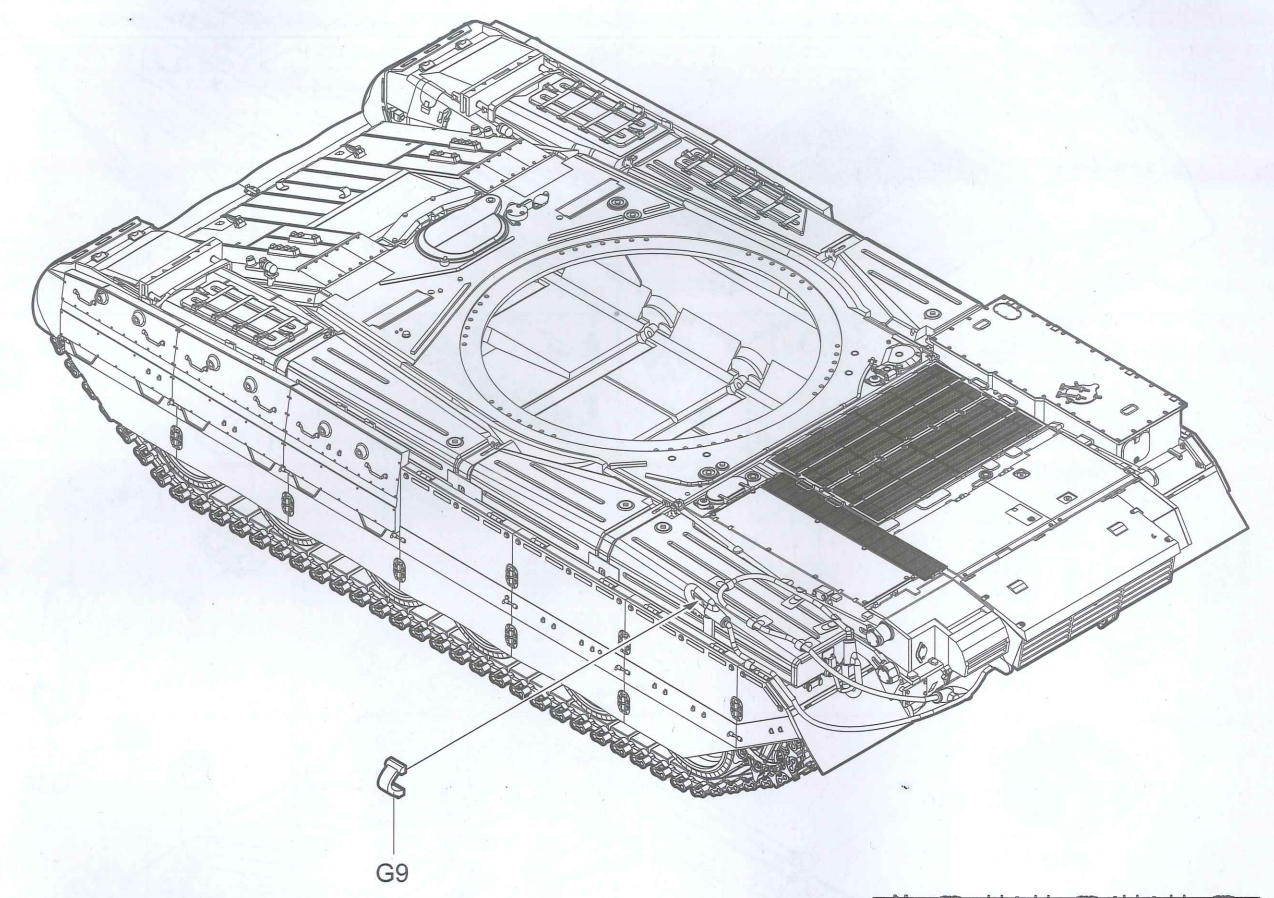

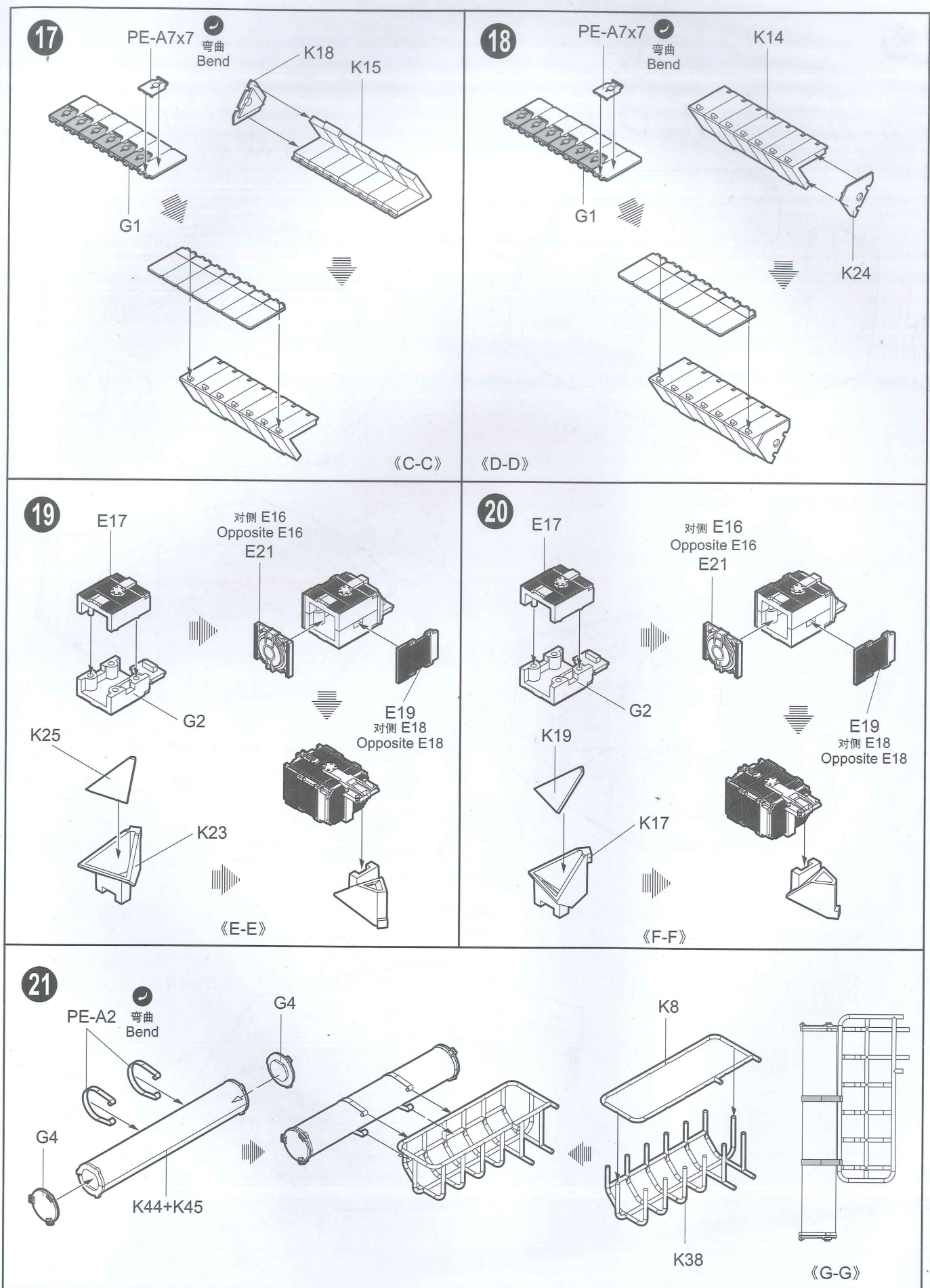
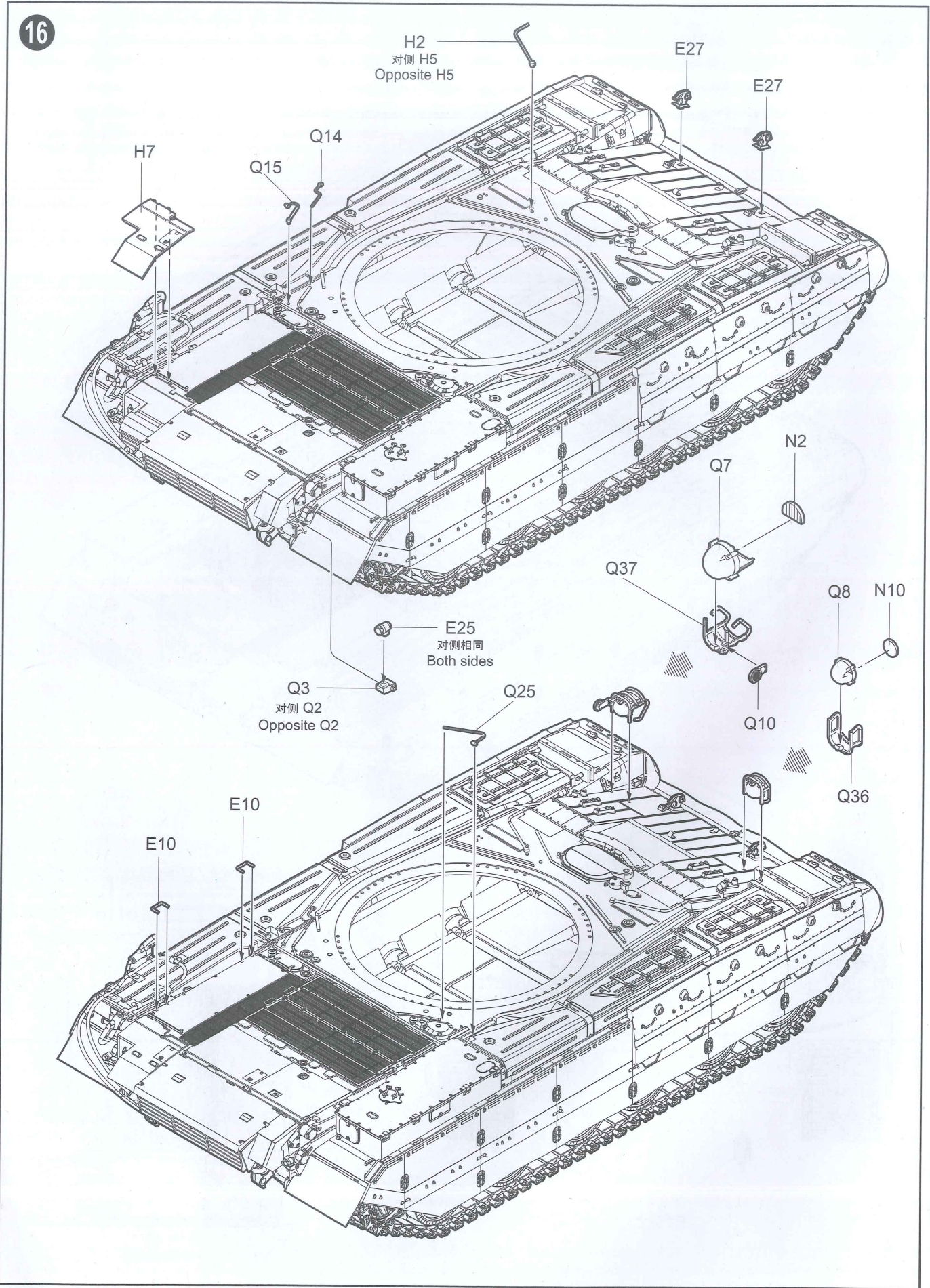

22

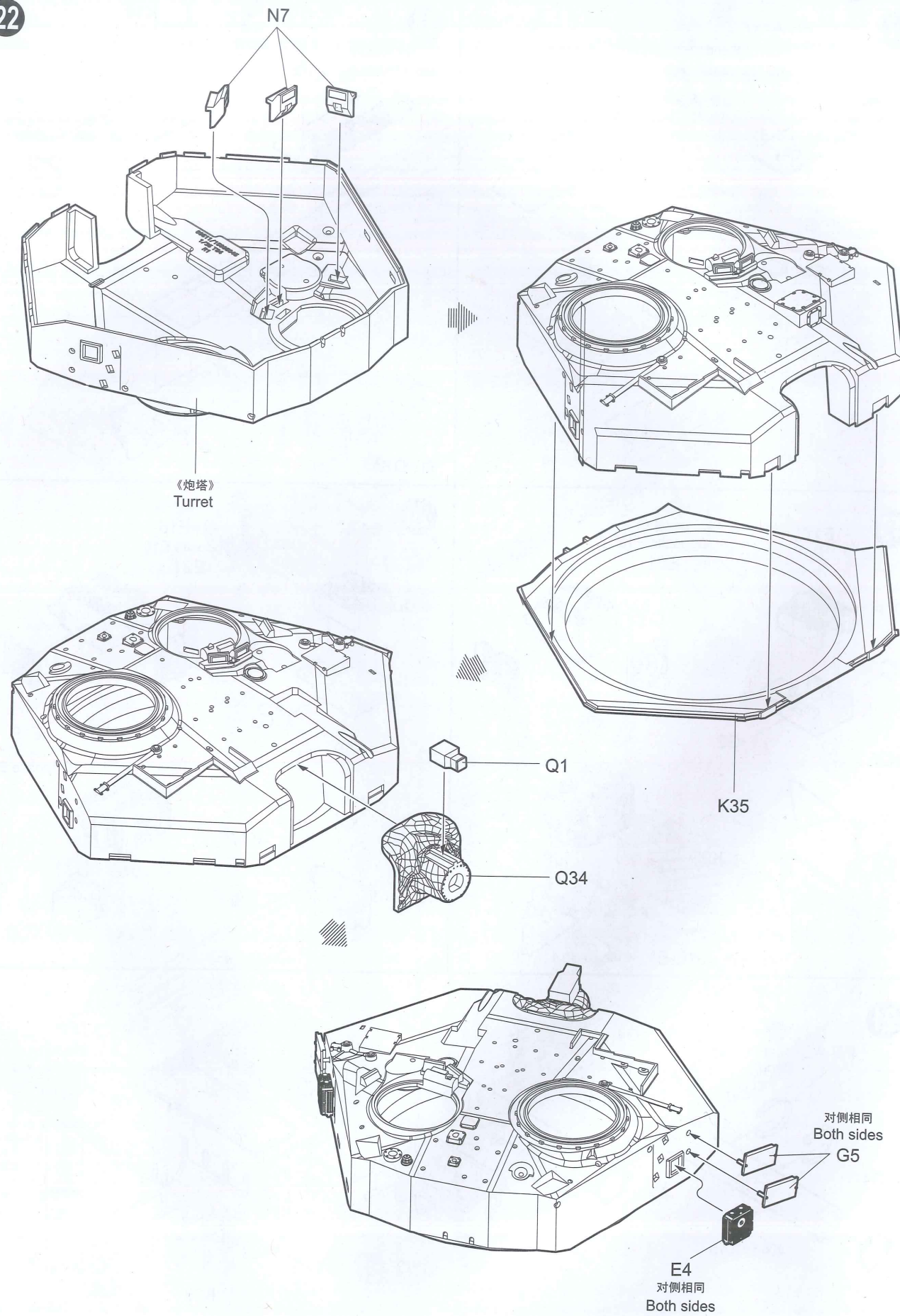

09511

16

23

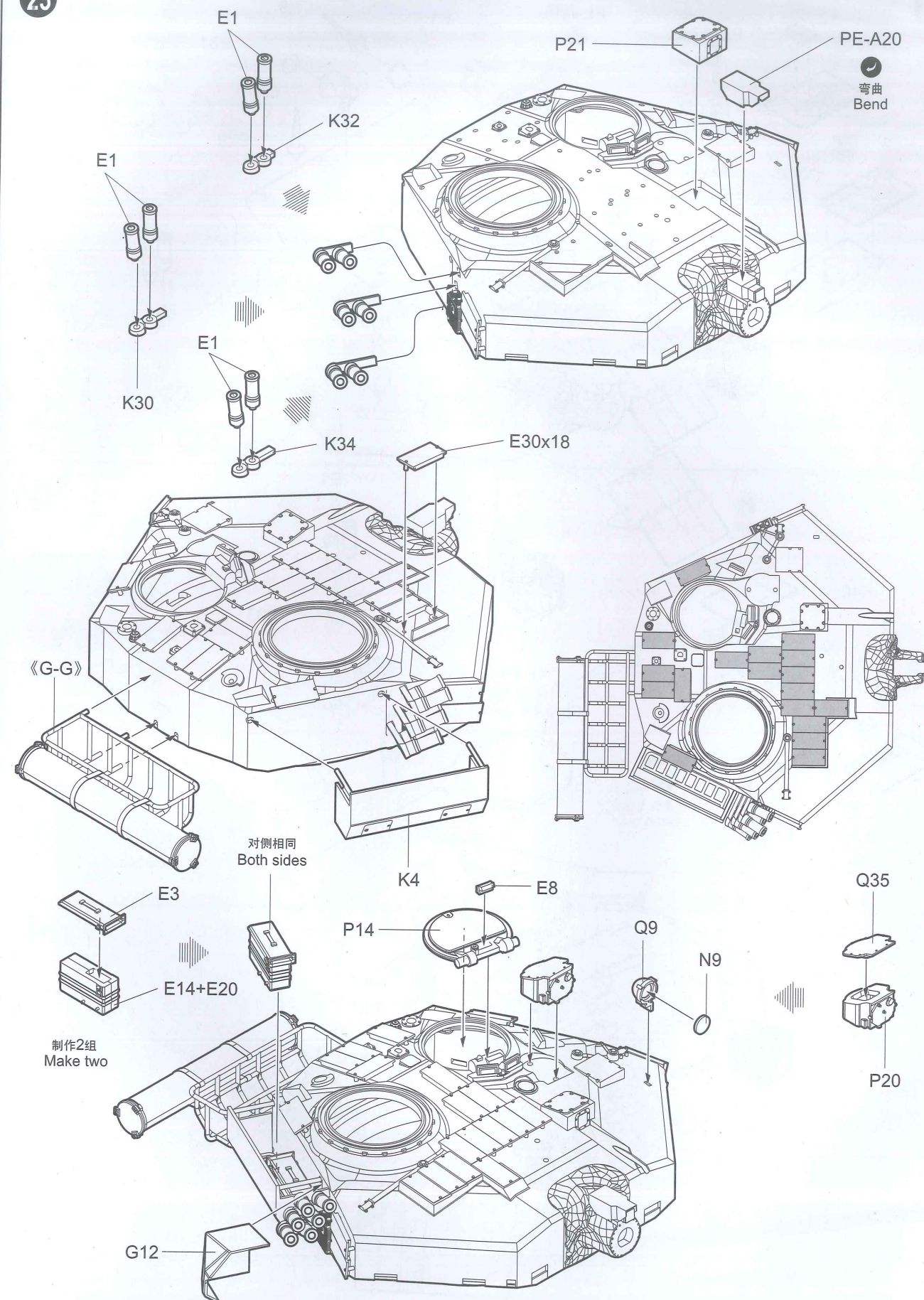

09511

17

24

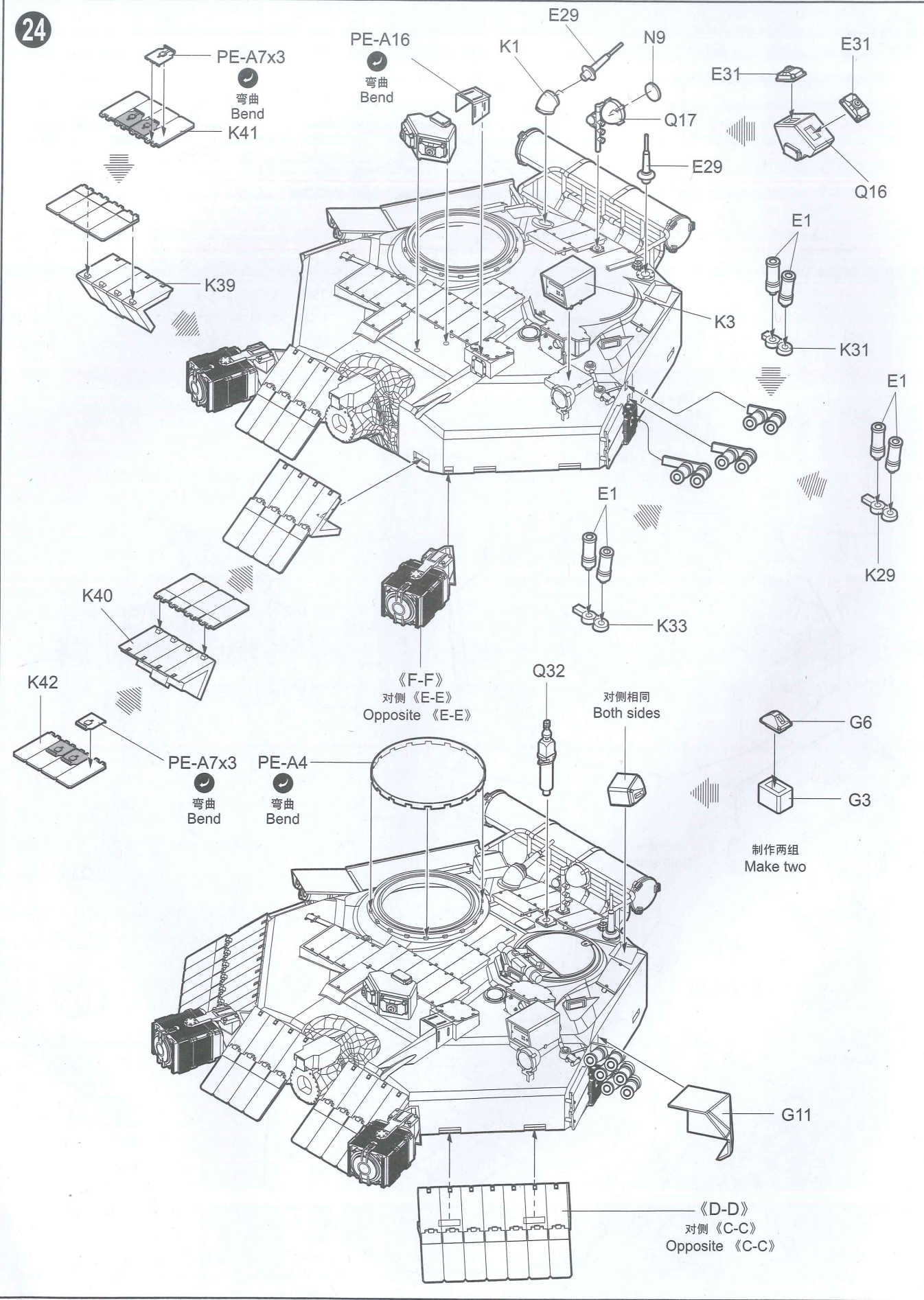

09511

18

25

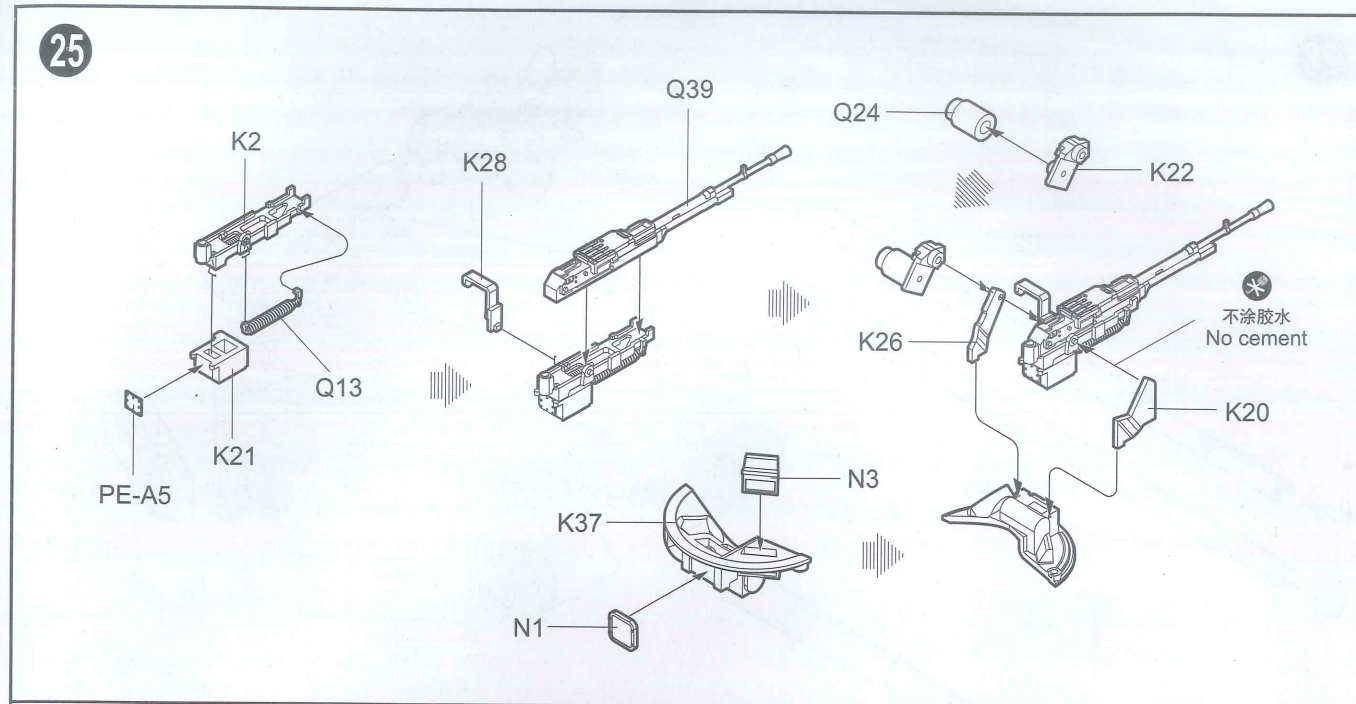

26

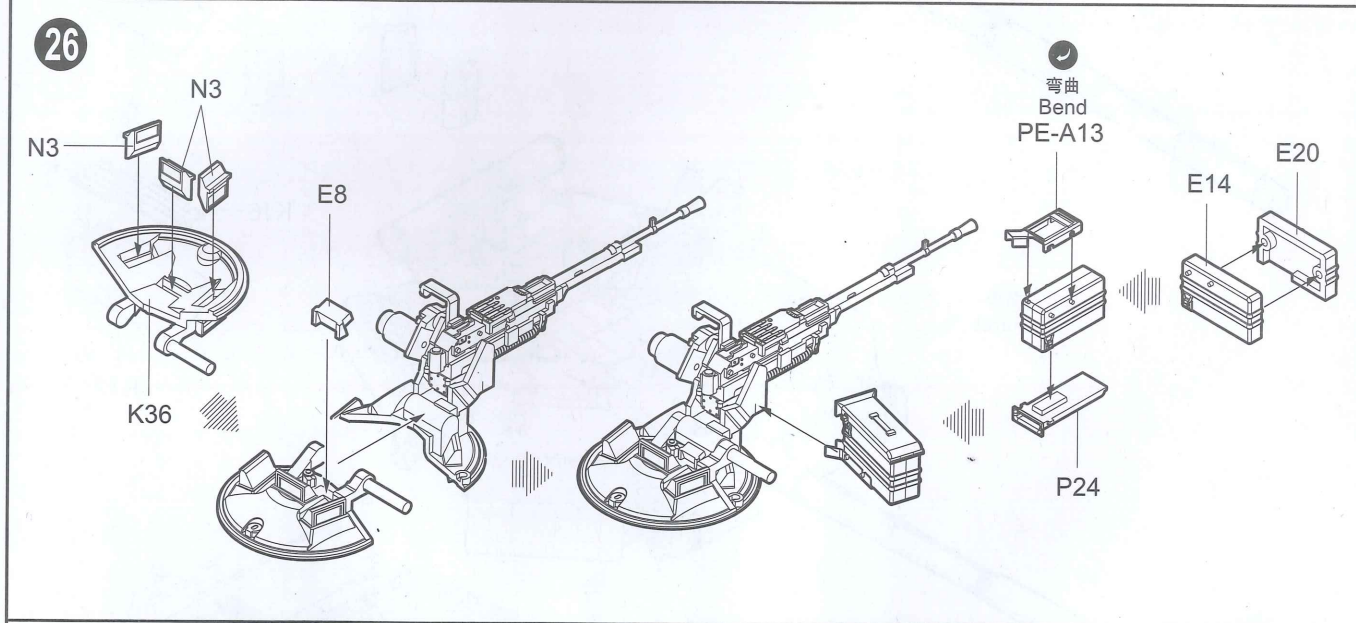

27

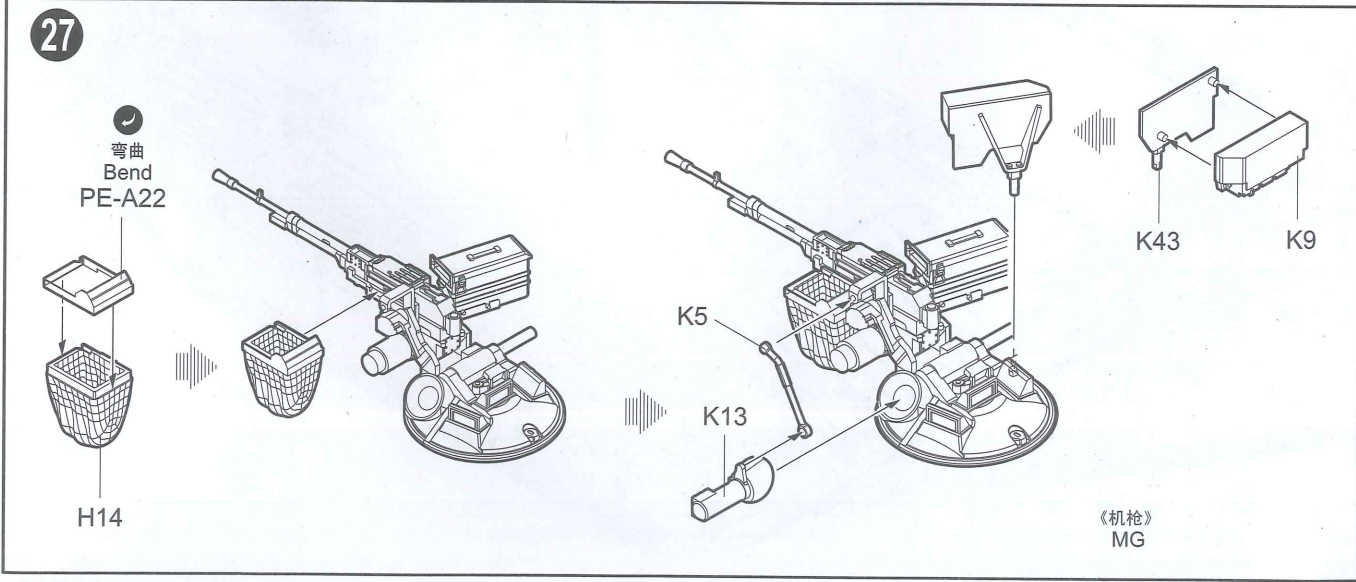

09511

19

