

WHITE FS36622
 GREEN FS34102
 BURNT METAL
 TAN FS30219
 DK. GREEN FS34079

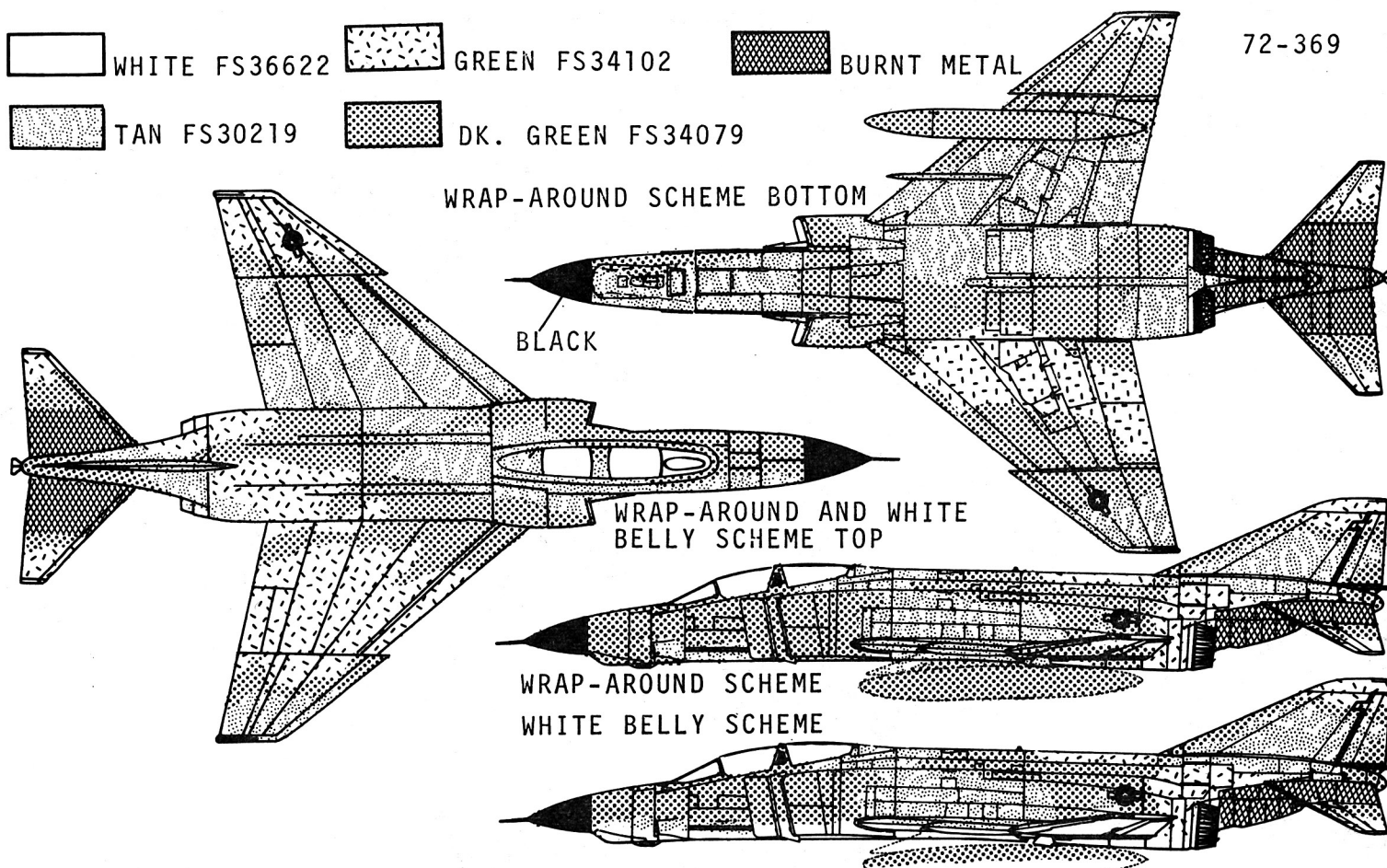

WHITE CARGO PODS ON ALL VERSIONS

McDONNELL RF-4C PHANTOM 64-0050
 173rd TACTICAL RECONNAISSANCE SQUADRON
 155th TACTICAL RECONNAISSANCE GROUP
 NEBRASKA ANG, LINCOLN AIRPORT NEBRASKA JULY 1982
 WRAP-AROUND CAMOUFLAGE SCHEME
 BLACK NATIONAL INSIGNIAS
 155th TRG BADGE

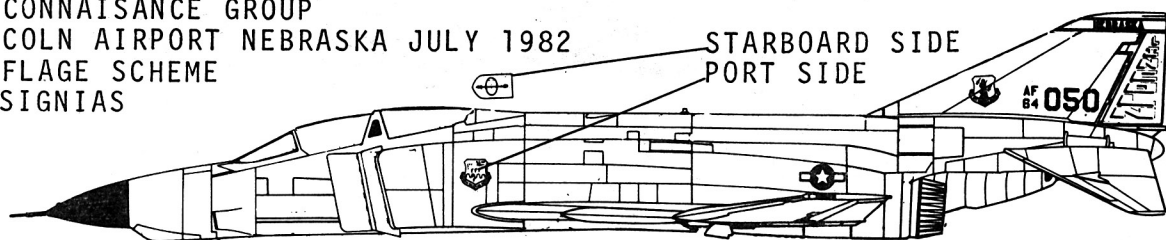

McDONNELL RF-4C PHANTOM 65-0828
 173rd TACTICAL RECONNAISSANCE SQUADRON
 155th TACTICAL RECONNAISSANCE GROUP
 NEBRASKA ANG LINCOLN, NEBRASKA
 NOV. 1981 "PHOTO FINISH" MEET
 STANDARD CAMOUFLAGE WITH WHITE BELLY
 BLACK NATIONAL INSIGNIA

MARKINGS ARE PROVIDED TO DO EITHER
 64-0050 OR 65-0028. TO DO 65-0828
 CUT DECAL AT THIS POINT.

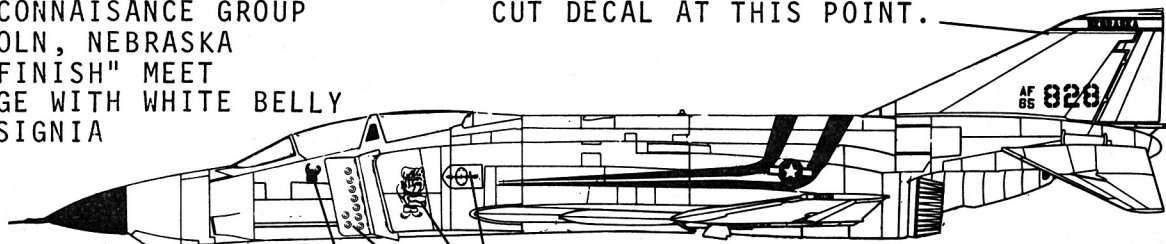

BOTTOM TIP OF LANDING GEAR DOOR

BOTH SIDES
 VIKING HELMET AND FILM CANISTERS
 PORT SIDE ONLY

RESEARCH BY BILL STRANBERG, GEORGE COCKLE, WILLIAN KNOOP,
 FRED HALL, CHARLES ARRINGTON, AND AL MONGEON VIA DON GARRETT.

McDONNELL RF-4C PHANTOM 65-0897
 192nd TACTICAL RECONNAISSANCE SQUADRON
 152nd TACTICAL RECONNAISSANCE GROUP
 NEVADA ANG RENO AIRPORT NEVADA
 "PHOTO FINISH" MEET NOV. 1981
 WRAP AROUND CAMOUFLAGE SCHEME
 RED WHITE AND BLUE
 NATIONAL INSIGNIA

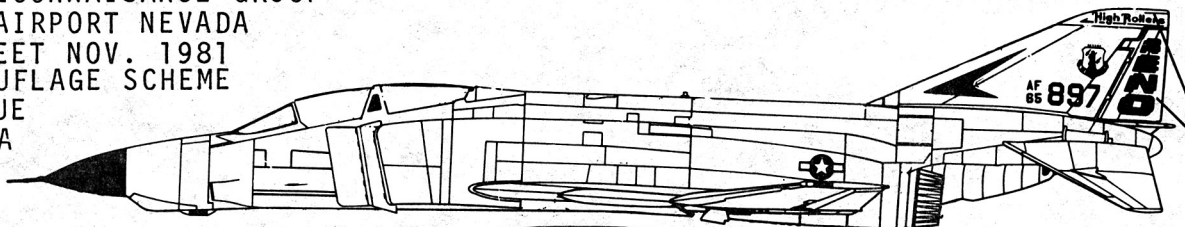

McDONNELL RF-4C PHANTOM 64-1063
 165th TACTICAL RECONNAISSANCE SQUADRON
 123rd TACTICAL RECONNAISSANCE WING
 MAY 1982, KENTUCKY ANG, LOUISVILLE A.P. KENTUCKY
 "BEST FOCUS 82" PHOTO MEET IN DENMARK
 THE UNIT WON THE "OUTSTANDING AIR FORCE UNIT AWARD" FOR 1982
 WRAP-AROUND CAMOUFLAGE SCHEME
 NOSE RADOME IS BLACK
 BLACK NATIONAL INSIGNIAS

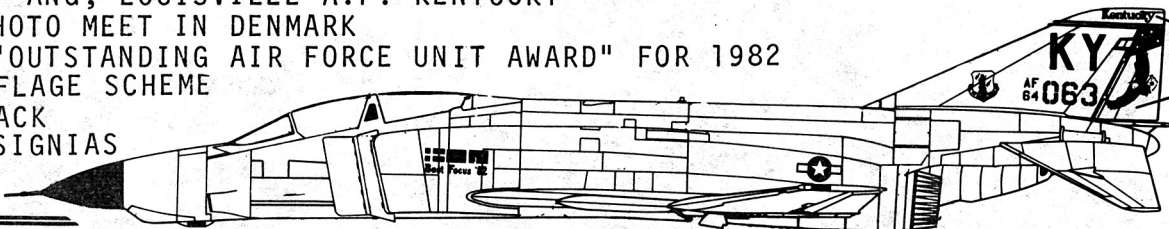

PAINT FIN AND RUDDER WHITE BEFORE DECALING

THIS IS AN AVERAGE REPRESENTATIVE OF MARKINGS
 TO BE FOUND ON THESE AIRCRAFTS. SHOULD YOU WISH TO
 FINISH YOUR MODEL WITH ALL OF THE FACTORY STENCILING
 AND INCLUDING ACCESS DOOR MARKINGS YOU MUST BUY
 72-164 BLACK STENCILING 72-237 WHITE STENCILING

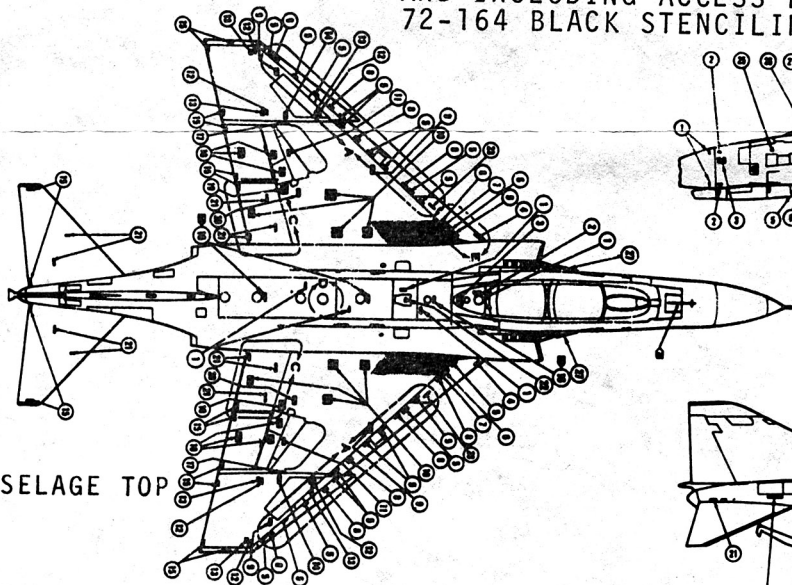

FUSELAGE TOP

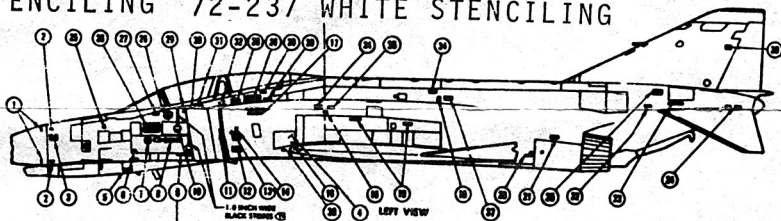

FUSELAGE LEFT SIDE

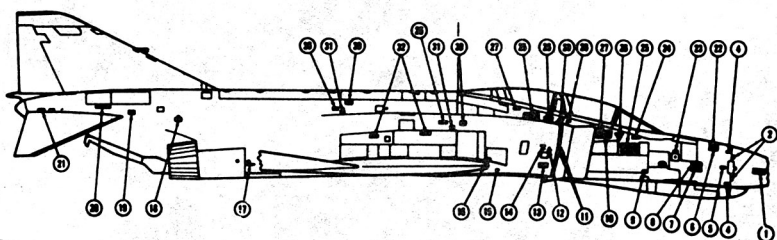

FUSELAGE RIGHT SIDE

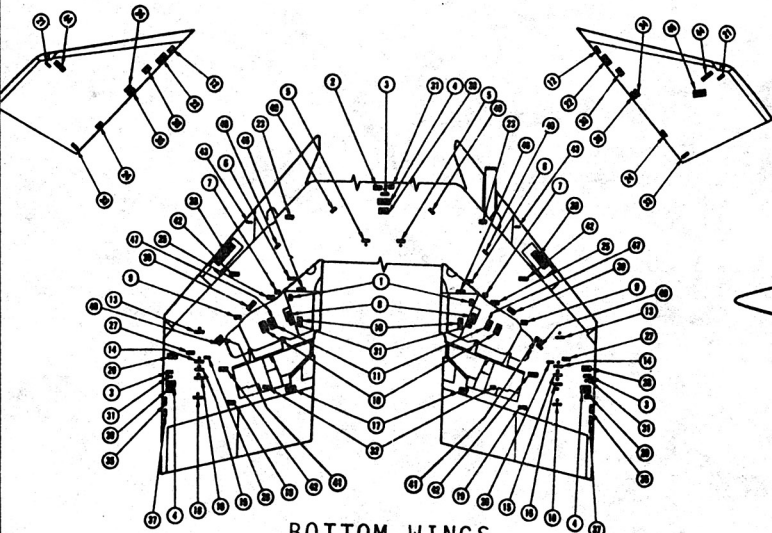

BOTTOM WINGS

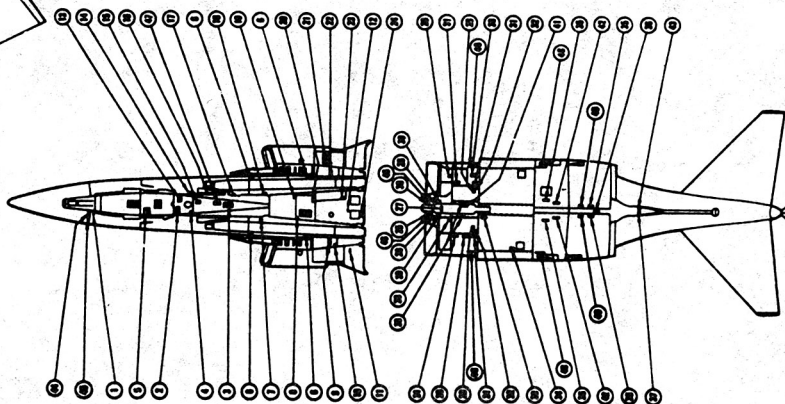

FUSELAGE BOTTOM