

1:35 '39-'45 SERIES

DAK Pz.Bef.Wg.III Ausf.H

 DRAGON



Thanks to TOM COCKLE and GARY EDMUNDSON as Technical Consultants.

KIT NO. 6901

Ax2

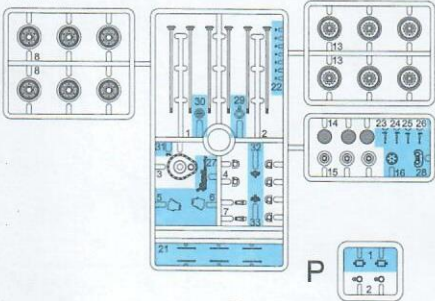

A

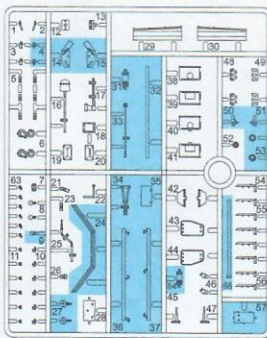

B

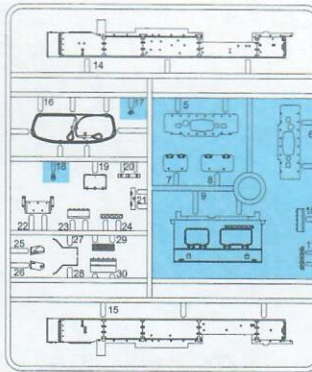

N

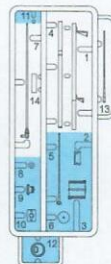

P

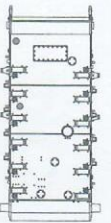

g

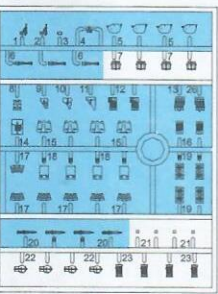

C

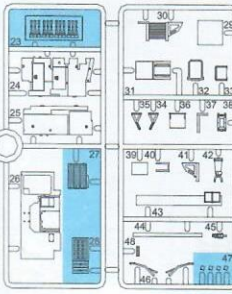

Wx2

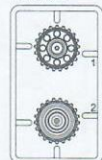

F

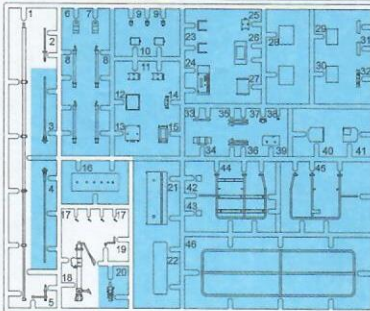

S



X

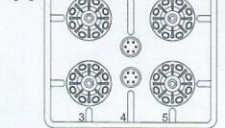

G

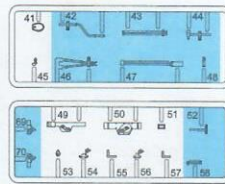

U

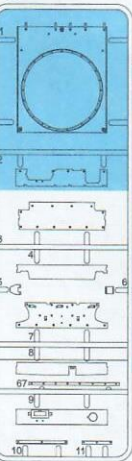

V

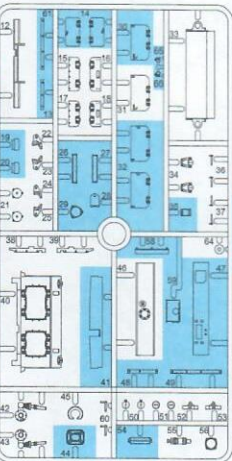

Yx2

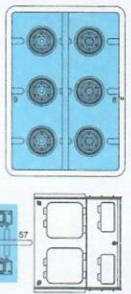

E

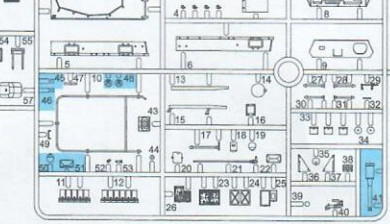

D

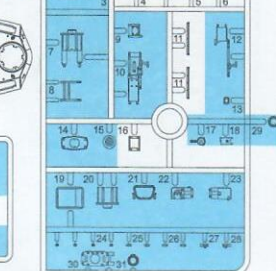

Z

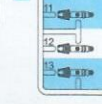

B

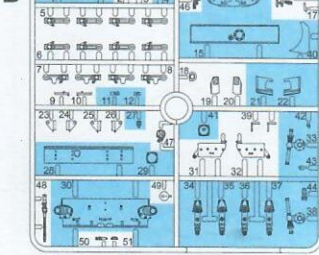

MA (Photo-etched Parts)

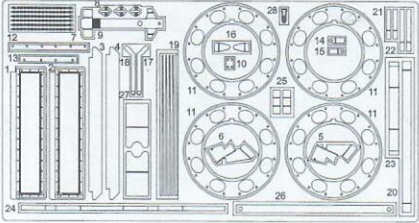

MagleTrack
 PATENT REGISTERED
 实用新型专利
 Wx216

F

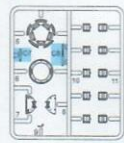

Tx2



M



中国語は使用しなす
 Parts not for use.
 Teils werden nicht verwendet.
 Pieces à ne pas utiliser.
 Part niet gebruikt.
 不需要使用的零件

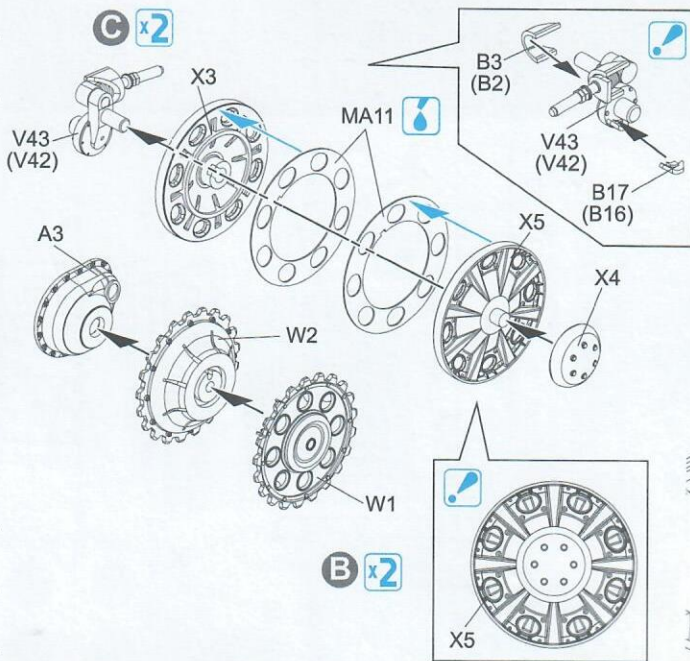

1

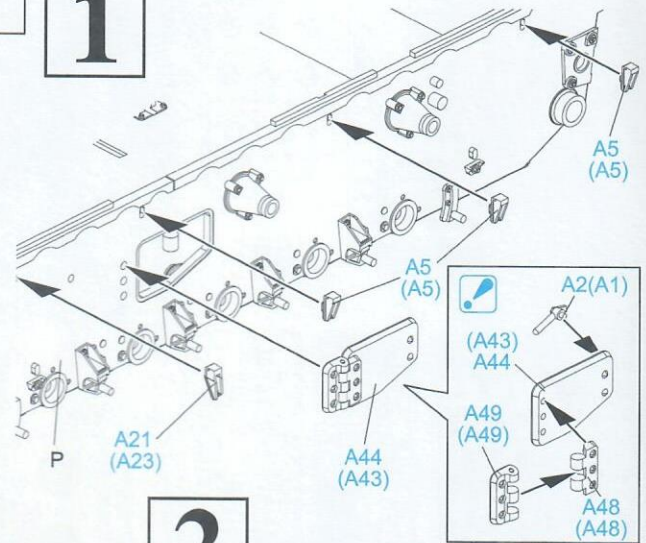

2

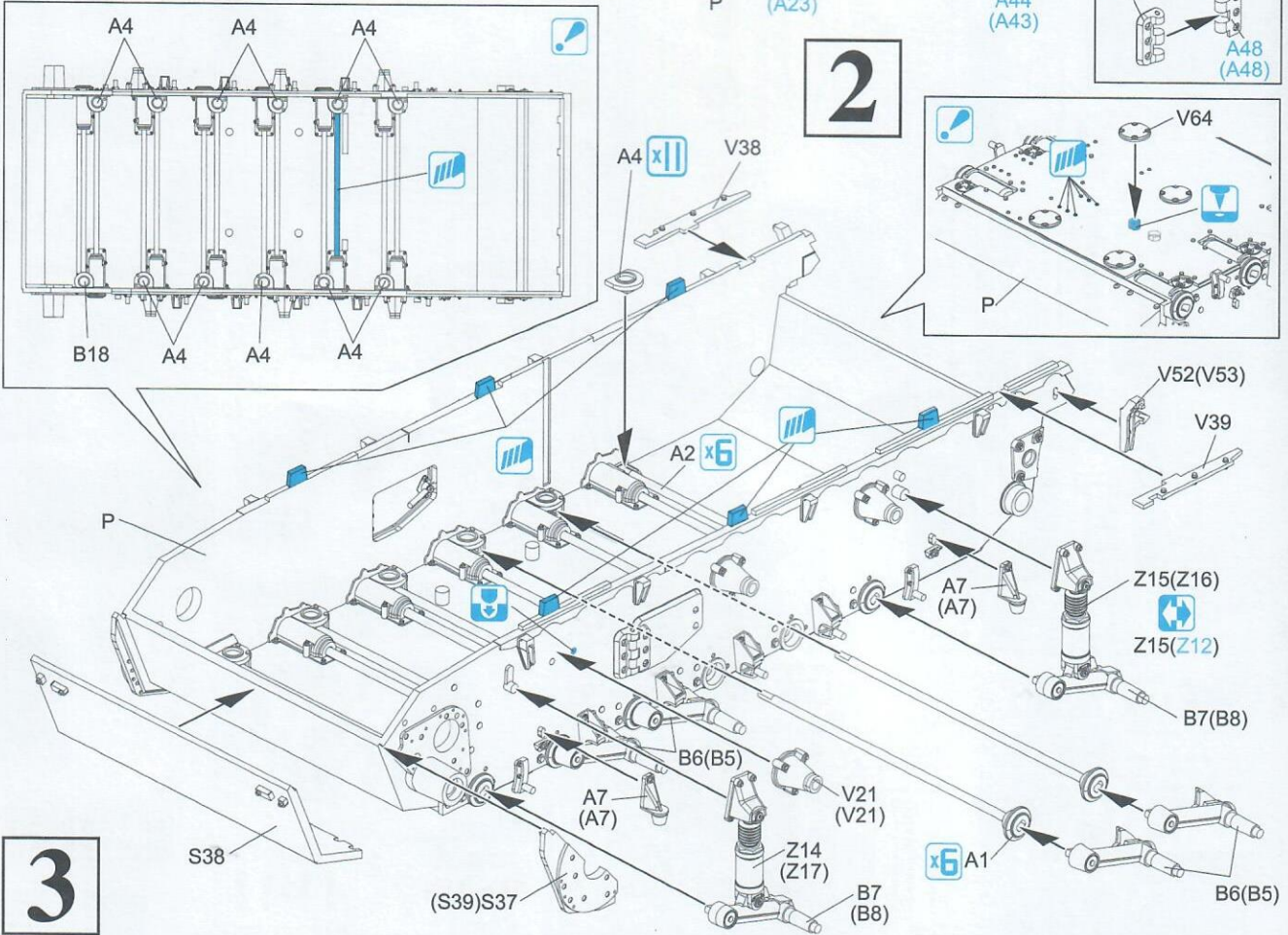
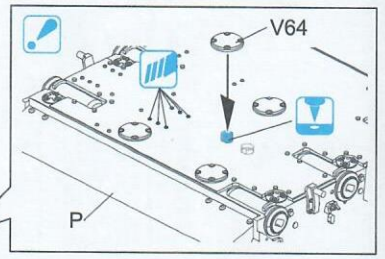
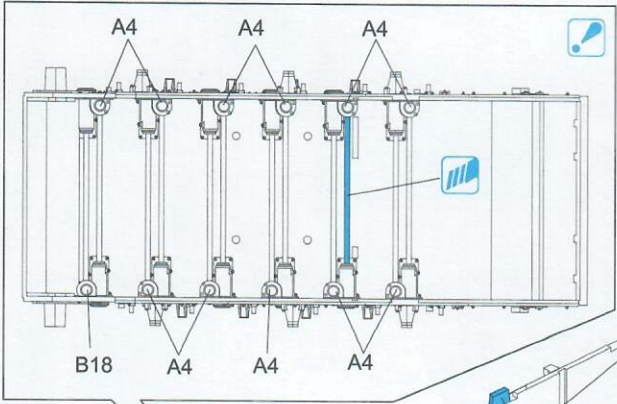

3

S38

4

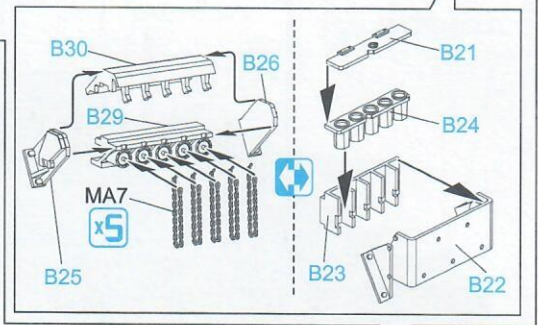
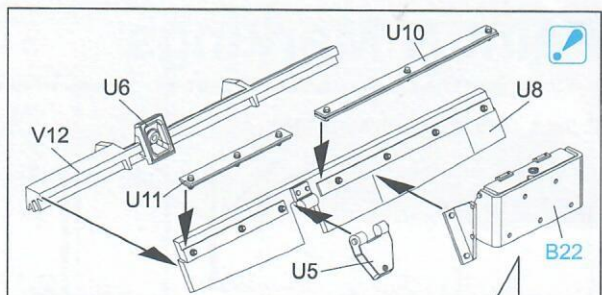
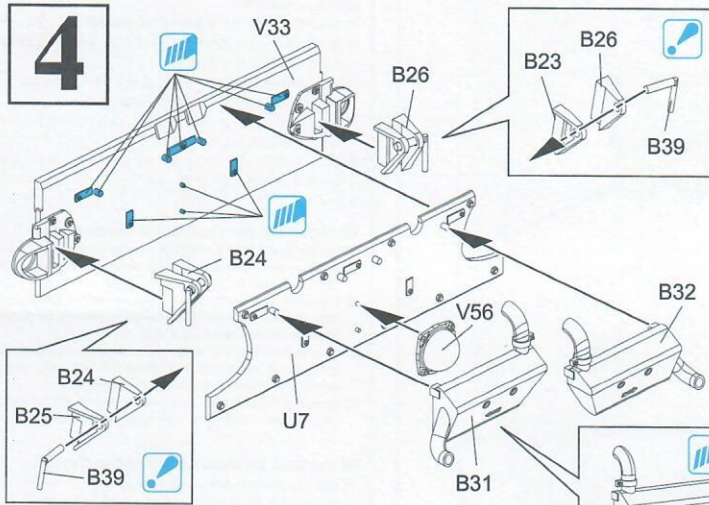

5

9

G

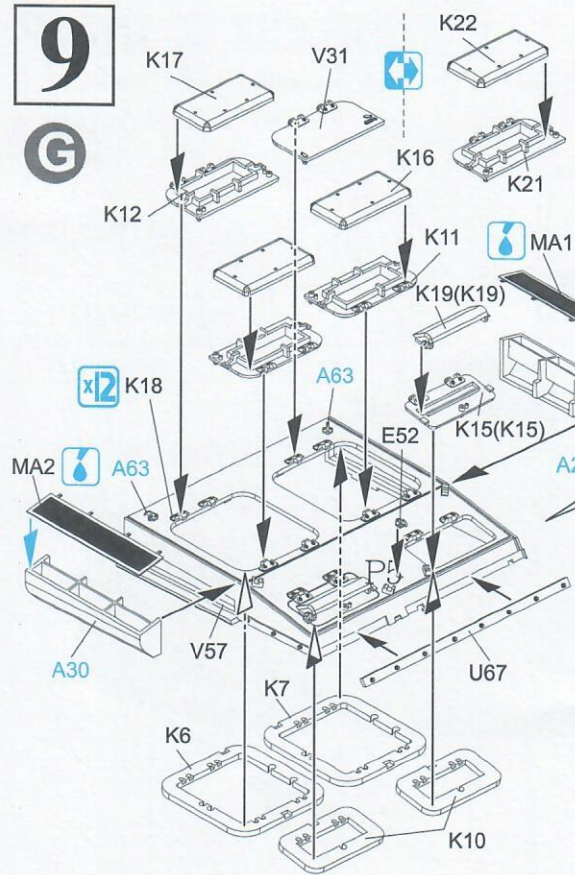

10

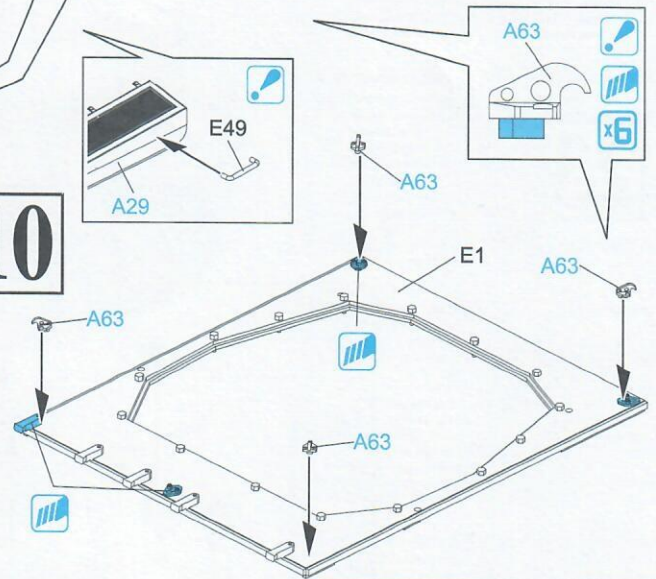
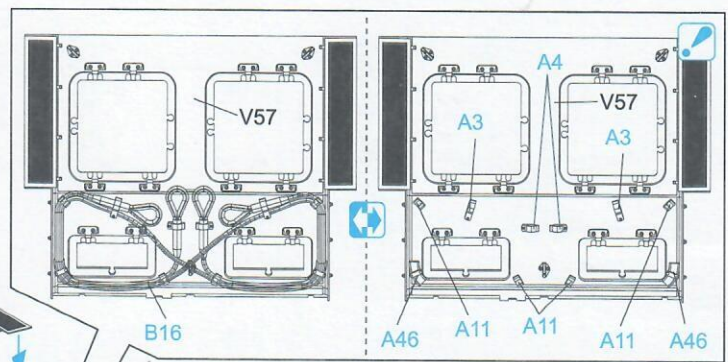

11

J

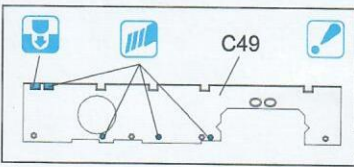
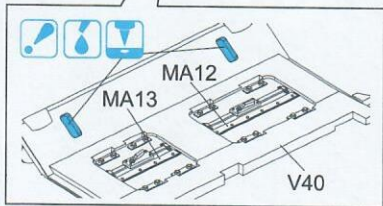
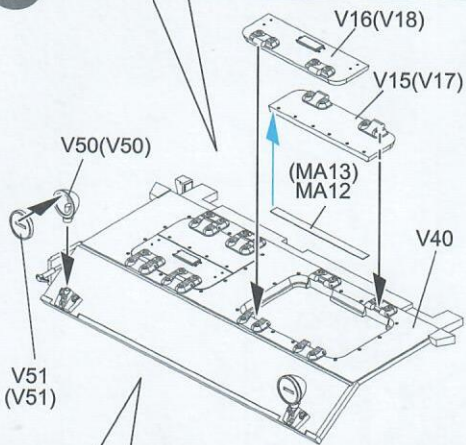
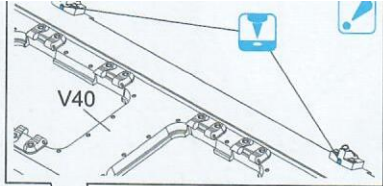

12

N

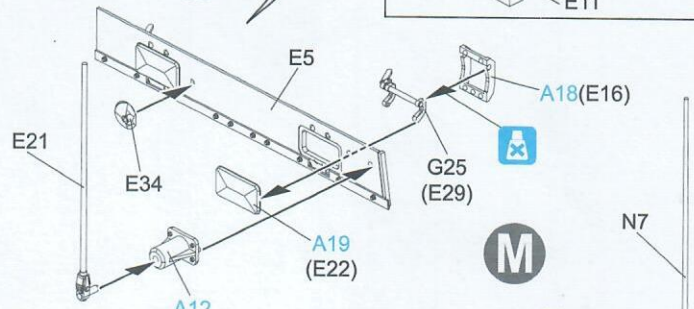
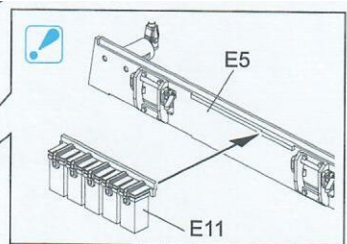

M

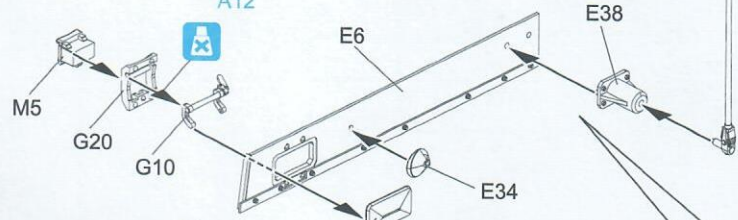

K

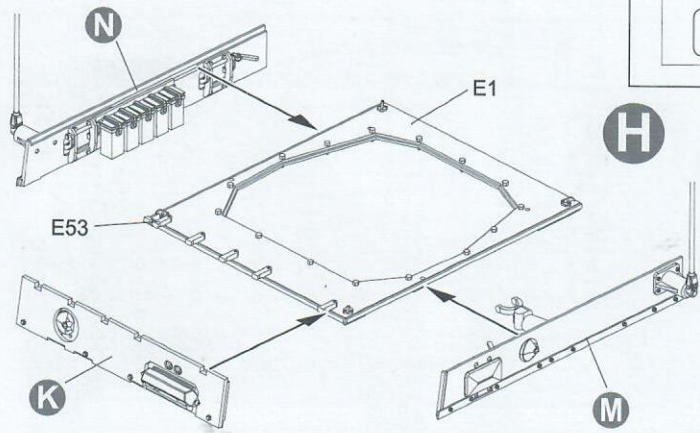
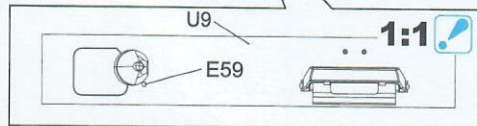
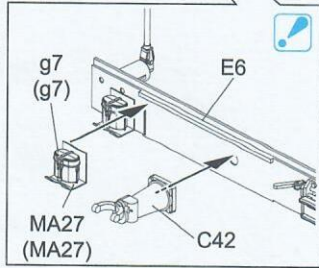
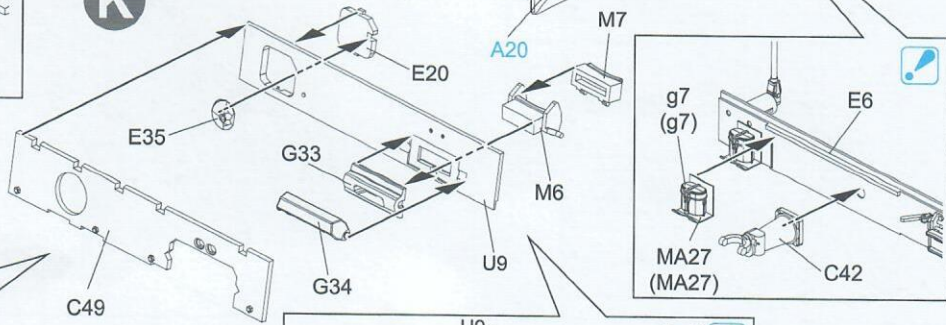

H

13

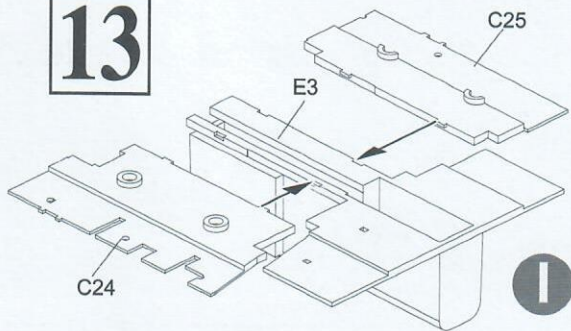

14

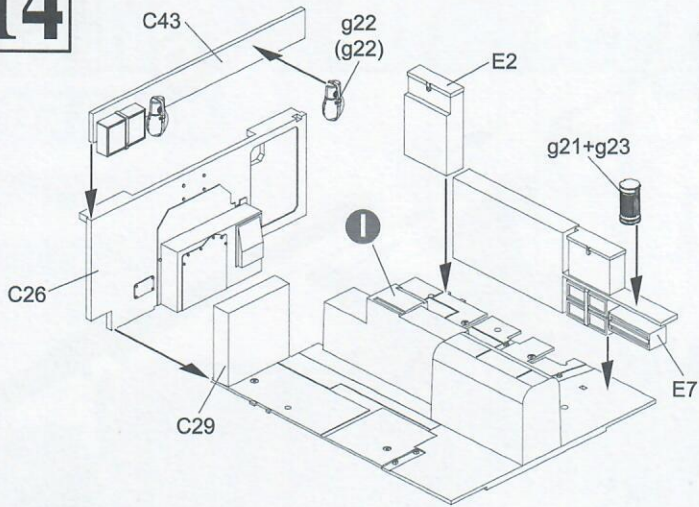

15 L

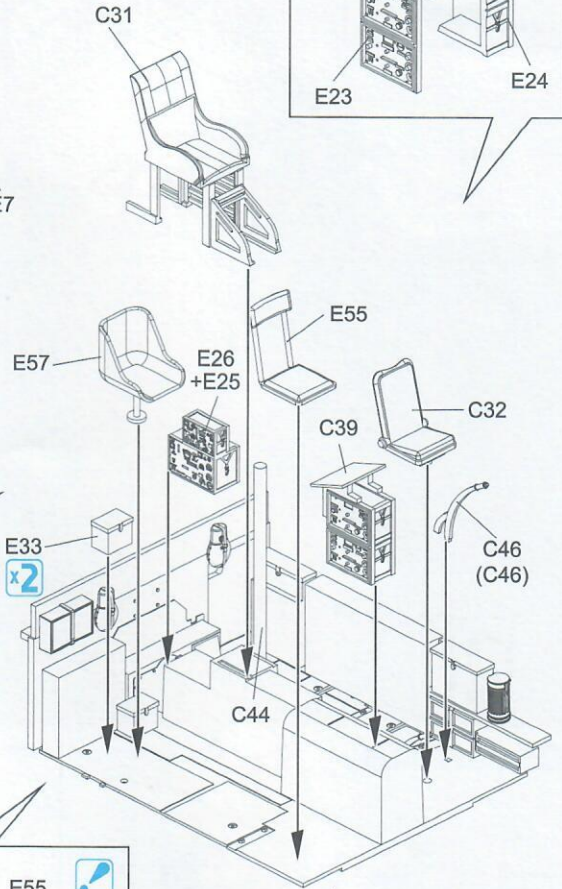
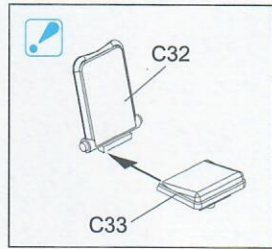
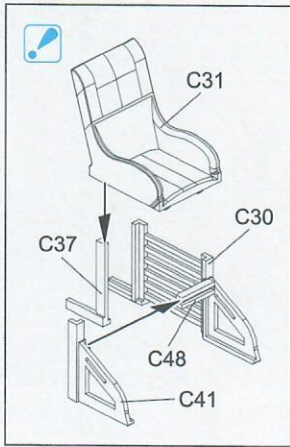
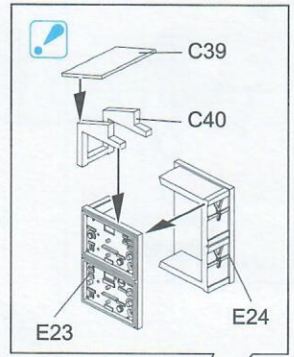

16 L

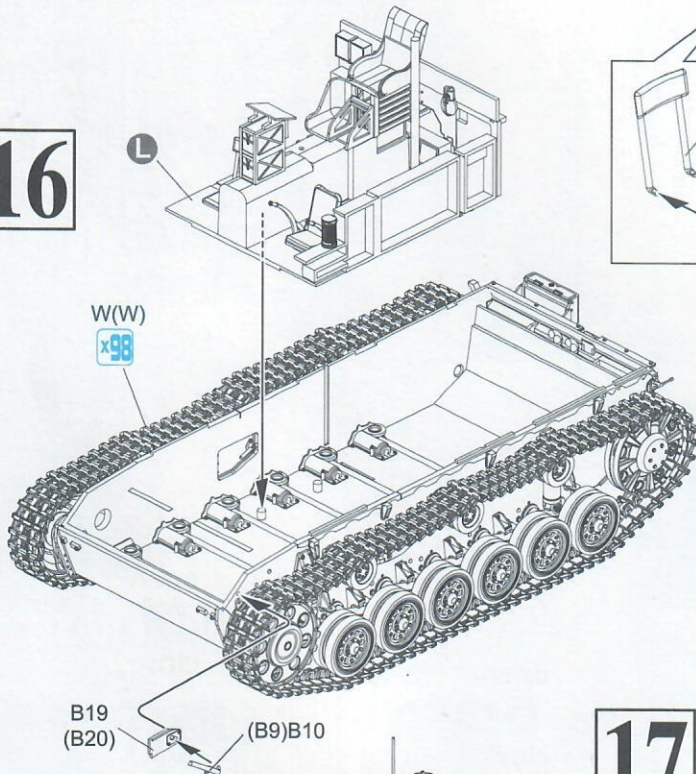

17

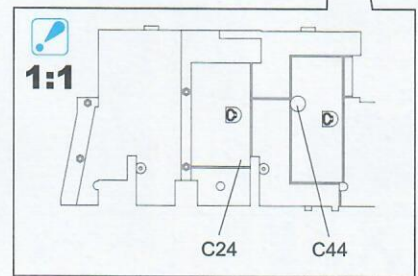
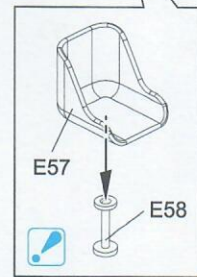

17

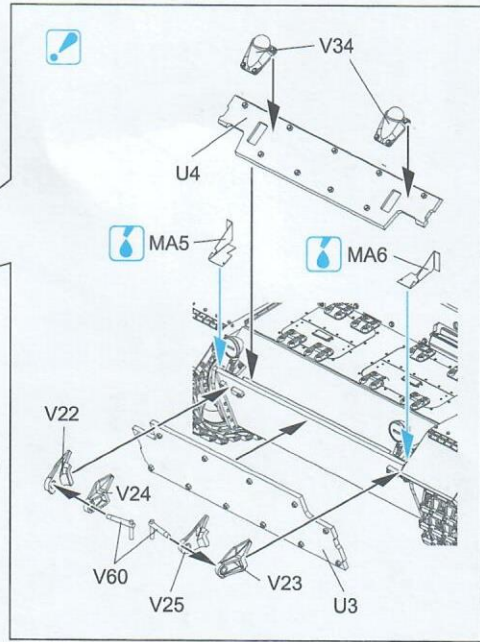
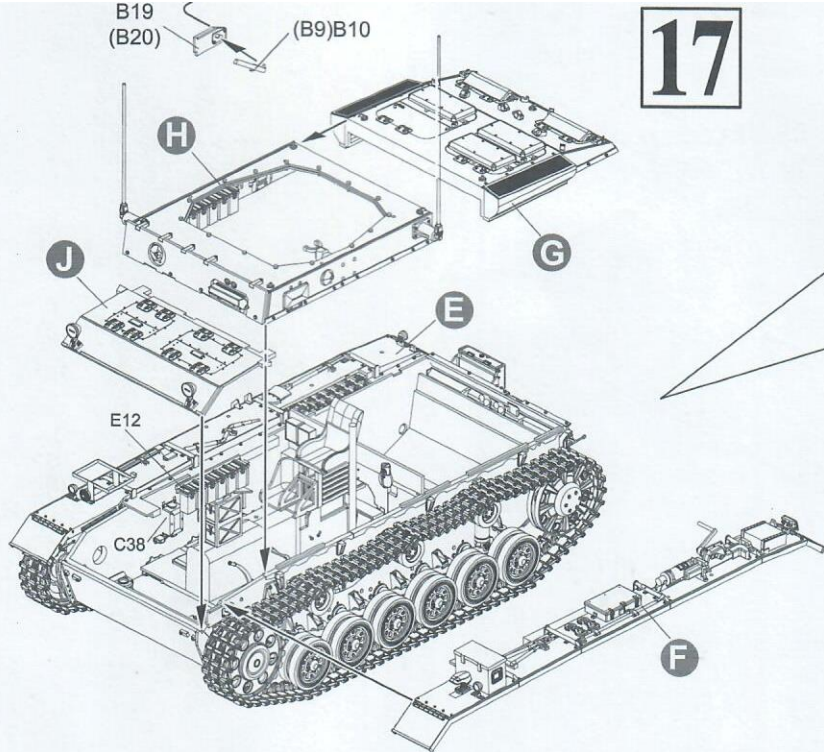

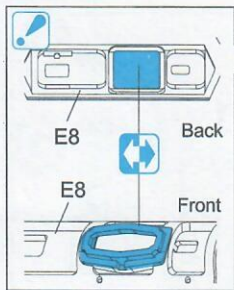

P

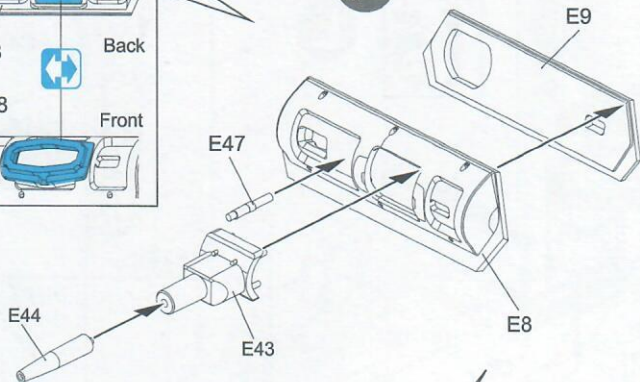

18

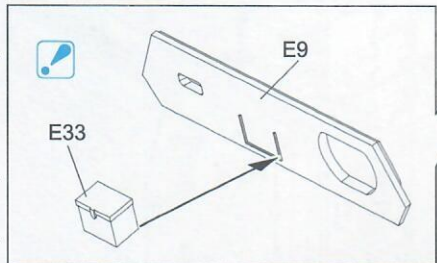

C35

19

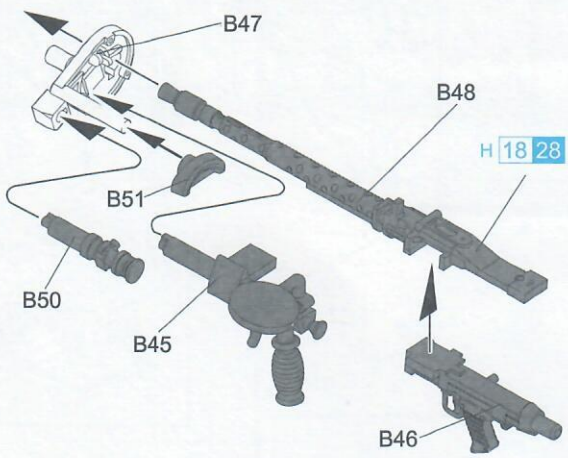

21

20

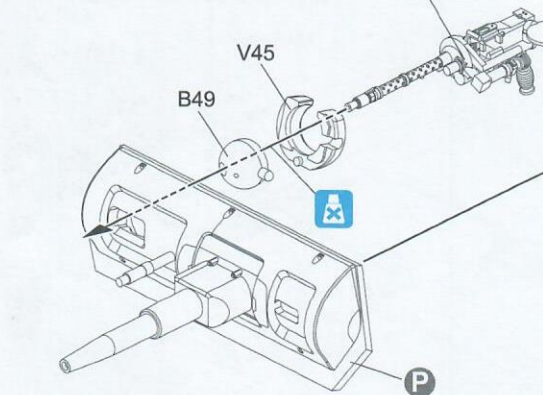
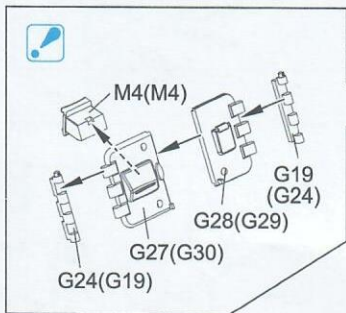
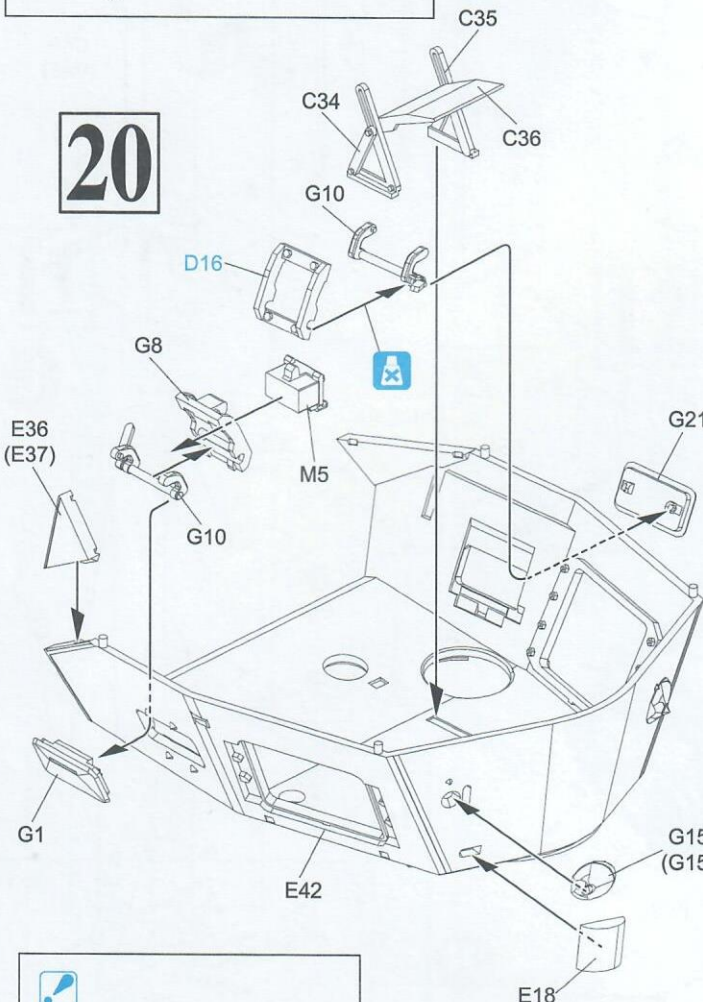

21

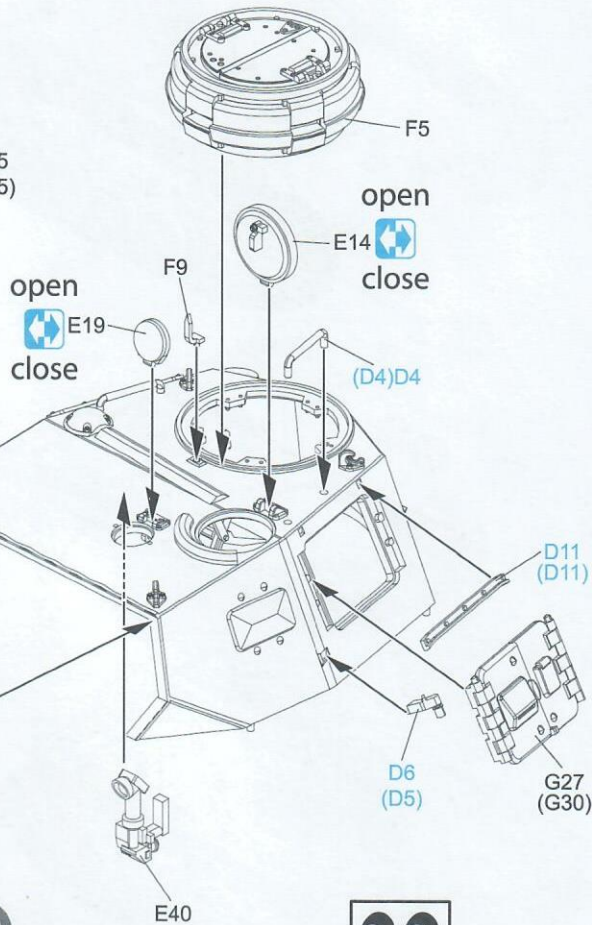
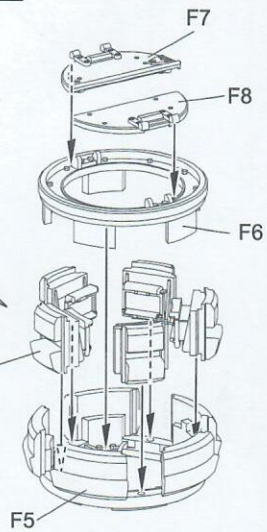
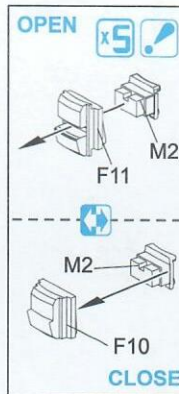

22

Q

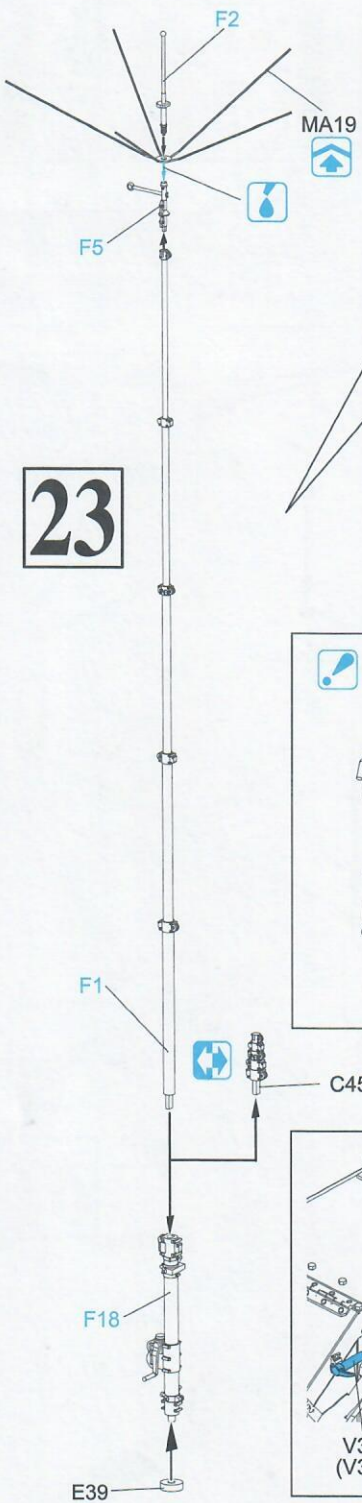

23

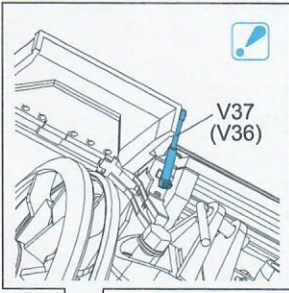
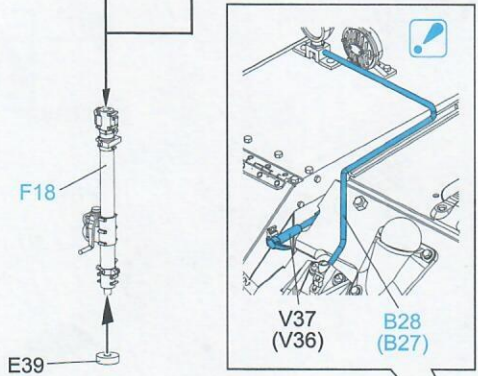
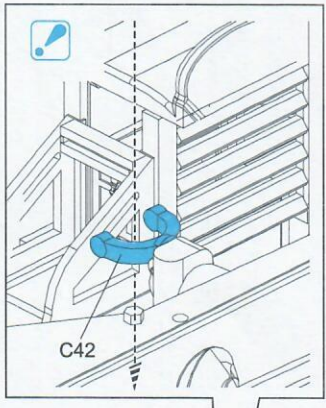
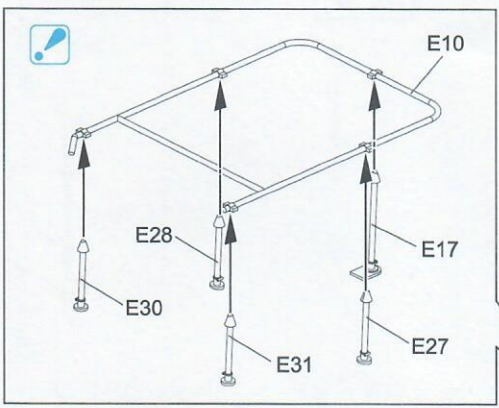
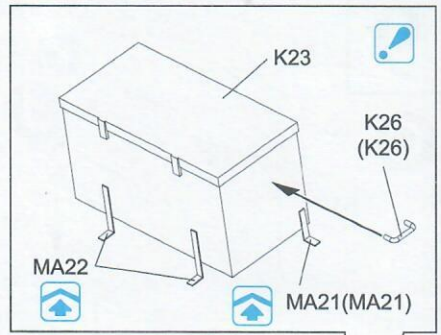
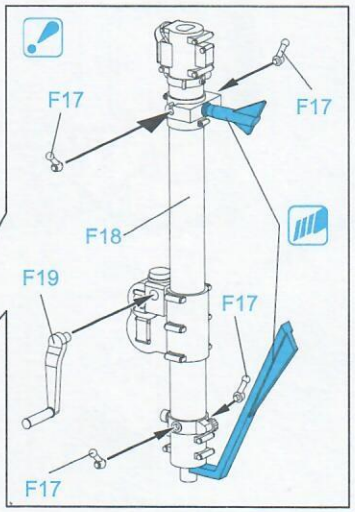

24

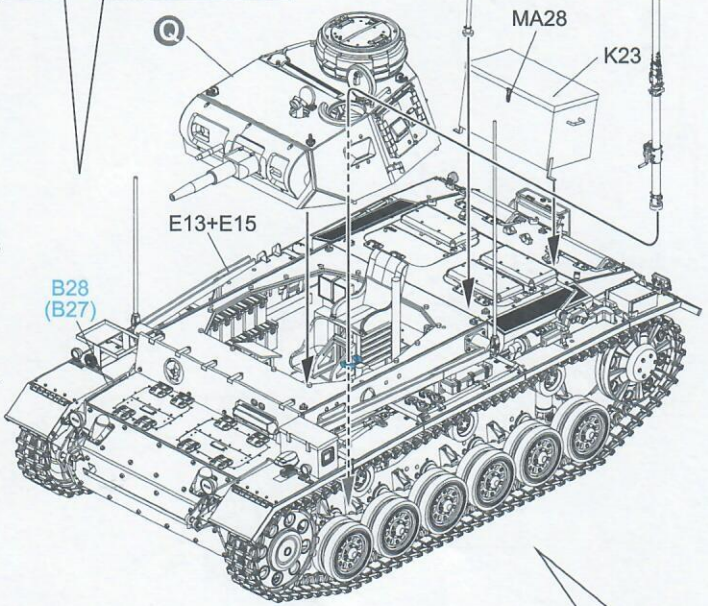
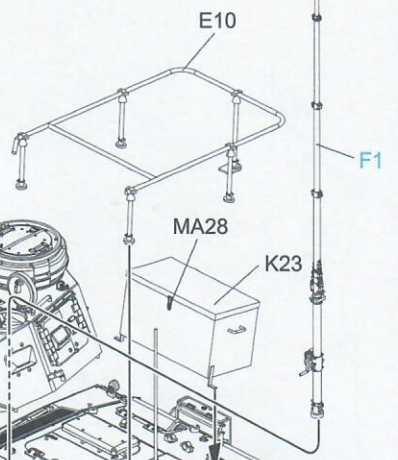
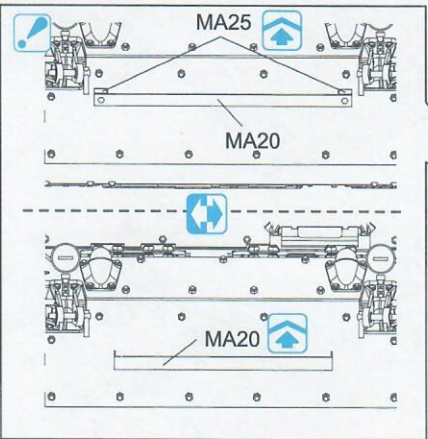

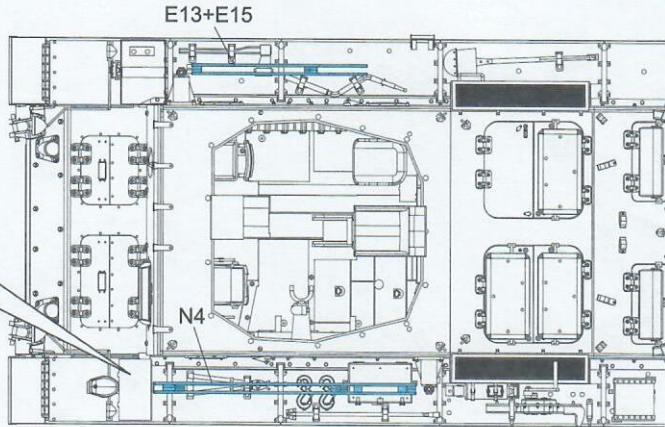
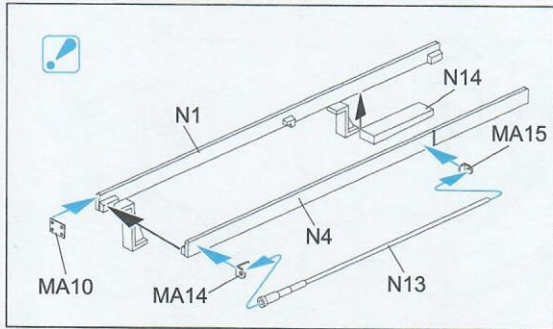

Paint & Markings

マーキング及び塗装図 Markierungen und Bemalung 標貼及着色指示 Decorat et Peinture Marchio & Pittura

Pz.Rgt.18, 15.Pz.Div., North Africa 1940

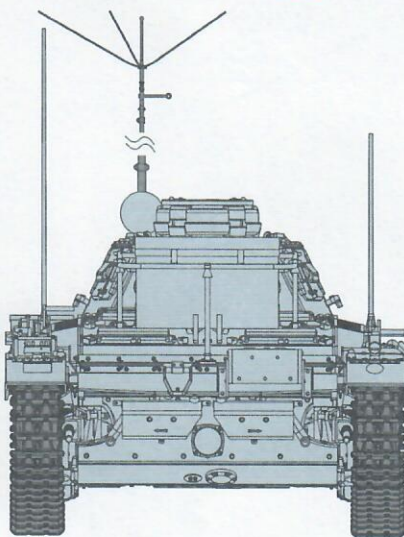
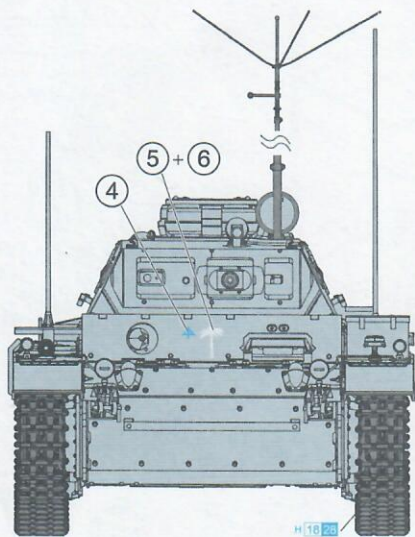
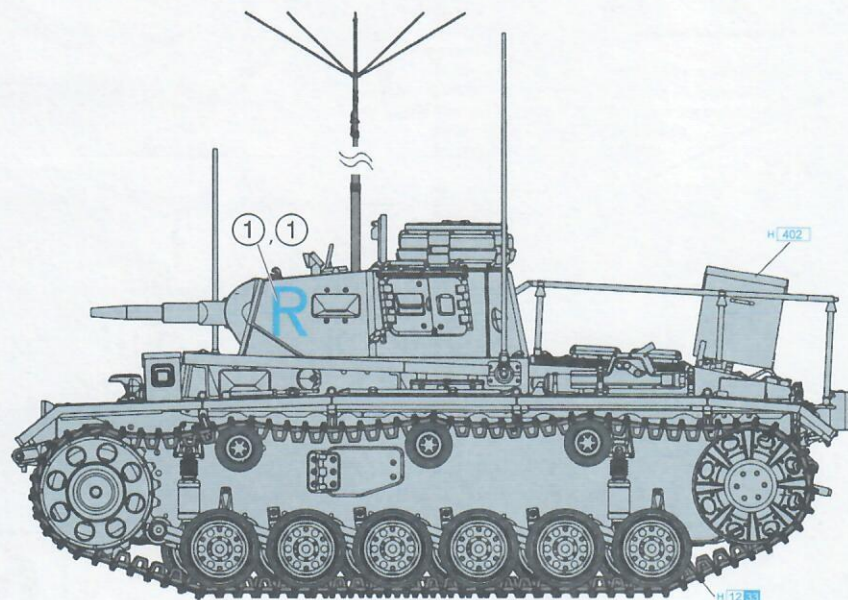

■デカールの貼り方

- ① あらかじめデカールを貼る場所の汚れを拭き取ってください。
- ② 貼りたいデカールを切り取り、1枚ずつ水、またはぬるま湯に台紙を下に20秒ほど浸します。
- ③ 水から引き上げたらタオル等に寄せ、指先で軽くか確かめます。その後、台紙をずらしながら所定の位置に貼ります。
- ④ 指先に少量の水をつけて微調整した後、柔らかな布等で内側の水分や気泡を押し出してください。
- ⑤ デカールが完全に乾いたら多少の水を含んだ布で、デカールまわりの糊を拭き取ってください。

■Modo esatto per applicare le decalcomanie

- ① Pulire la superficie del modello con un panno umido.
- ② Ritagliare ciascun disegno dal foglio decalcomanie e immergerli in acqua calda per 20 secondi.
- ③ Controllare col polpastrello se il disegno è allentato sulla base di carta. In questo caso, applicarlo nella esatta posizione sul modello facendolo scivolare dalla base di carta.
- ④ Spostare il disegno nella esatta posizione mediante il polpastrello umido, quindi togliere l'acqua in eccesso e le bolle d'aria sotto la decalcomanie mediante un panno soffice di cotone.
- ⑤ Quando la decalcomanie sono asciutte, togliere con un panno umido l'eccesso di colla intorno alla decalcomanie stessa.

■Correct Method for Applying Decals

- ① Clean the model surface with a wet cloth.
- ② Cut out each decal design from the decal sheet, and dip it in warm water for 20 seconds.
- ③ Use a fingertip to check if the decal is loose from the backing paper. If so, place it in the proper position on the model, and slide it off the backing paper onto the model.
- ④ Move the design to the exact position with a wet fingertip, and squeeze out any excess water or air bubbles under the decal with a soft cotton cloth.
- ⑤ When the decals are dry, use a wet cloth to gently wipe away any residue left around them.

■Comment appliquer les décalcomanies correctement

- ① Nettoyer la surface du modèle avec un chiffon humide.
- ② Découper chaque décalcomanie de sa feuille de papier et la plonger dans l'eau tiède pendant vingt secondes.
- ③ Vérifier avec le bout du doigt si le dessin se détache de son papier-support. Si oui, le positionner à l'endroit choisi sur le modèle et retirer doucement le papier-support.
- ④ Positionner la décalcomanie correctement avec un doigt humide et éponger tout restant d'eau et toutes bulles d'air sous la décalcomanie avec un chiffon doux.
- ⑤ Quand les décalcomanies sont sèche, détacher le colle autour des décalcomanies avec un chiffon humide.

■Das Korrekte Aufbringen der Abziehbilder

- ① Oberfläche des Modells mit feuchtem Tuch reinigen.
- ② Jedes Motiv einzeln aus dem Bogen heraus schneiden und 20 Sekunden in warmes Wasser tauchen.
- ③ Mit dem Finger prüfen, ob sich das Motiv vom Trägerpapier gelöst hat. Wenn ja, so schieben Sie es vom Papier weg und seine genaue Position auf dem Modell.
- ④ Korrigieren Sie die exakte Lage mit nasser Fingerspitze und drücken Sie Wasserblasen unter dem Abziehbild mit einem weichen Baumwolltuch weg.
- ⑤ Entfernen Sie beim Antrocknen der Abziehbilder die Klebmittelränder mit einem feuchten Tuch.

■貼上水印標貼的正確方法：

- ① 用濕布抹乾淨模型表面。
- ② 按照各標貼的形狀從標貼紙上切出，浸到溫水之中約20秒。
- ③ 用指尖試行觸摸以確定標貼是否已脫離底紙，如果屬實，則把標貼連底紙放到模型表面的適當位置上，小心地將底紙移去，把標貼留在模型表面。
- ④ 以濕水的指尖把標貼移到正確的位置上，再用柔軟的綿質布把標貼腳壓，以擠出標貼底下的氣泡和水分。

Unidentified Unit, North Africa 1940

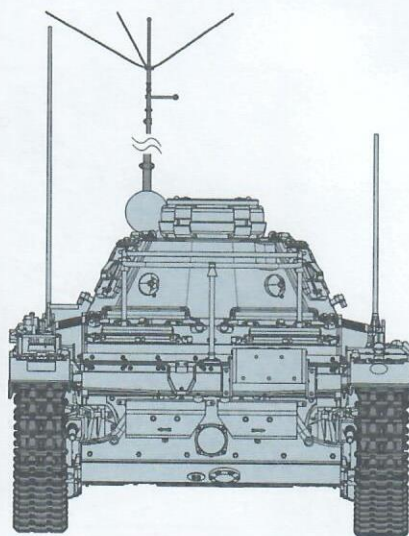
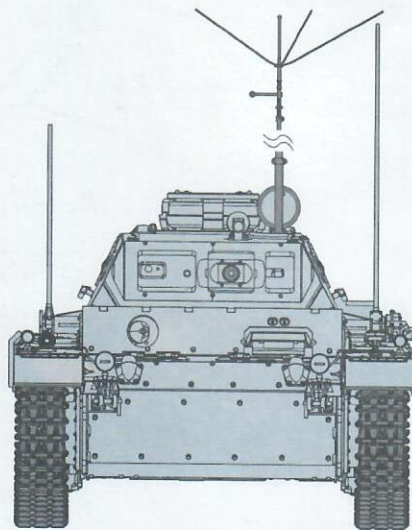
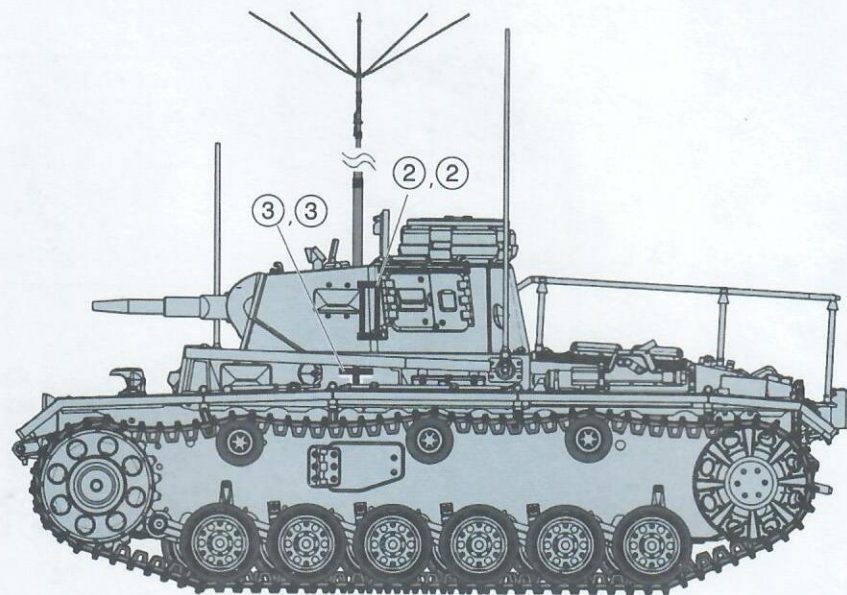

貼輕壓，以擠出標貼底下的氣泡和水份。
⑤ 標貼乾後，用濕布輕拭標貼及其附近的模型表面，以洗去可能殘留在標貼附近的多餘膠水，確保效果完美。

Dragon Europe: c/o Hobby Pro Marketing Ges. m.b.H.
Am Leonhardbach 7, A-8010 GRAZ, AUSTRIA



Copyright © 2017
6901-01