



**F-14D**

# SUPER TOMCAT



**1/48 UNASSEMBLED MODEL KIT**

INSTRUCTIONS

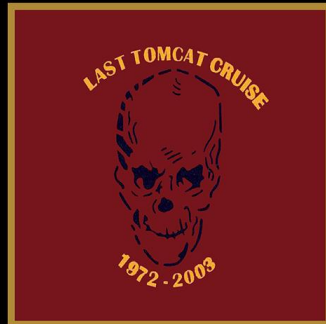

# F-14D SUPER TOMCAT

## 雄貓戰鬥機

The final variant of the Grumman F-14 was the F-14D "Super Tomcat". The F-14D variant was first delivered in 1991 where the original TF-30 engines were replaced with General Electric F110-400 engines, similar to those aboard the F-14B.

The F-14D also included updated digital avionics systems including a digital cockpit and replaced the AWG-9 with the newer AN/APG-71 radar. Other systems included the Airborne Self Protection Jammer (ASPJ), Joint Tactical Information Distribution System (JTIDS), SJU-17(V) Naval Aircrew Common Ejection Seats (NACES), and Infra-red search and track (IRST) situated in the chin pod.

The GE F110-400 engine provided increased thrust and additional endurance to extend range or to provide enhanced duration "On Station". The new engines also increased thrust and improved The Rate of Climb by 61%.

Although the F-14D was to be the definitive version of the Tomcat, not all fleet units received the D variant. In all, a total of 37 new aircraft were completed, and 18 F-14A models were upgraded to D-models. An upgrade to the F-14D's computer software allowed for AIM-120 AMRAAM missile capability but was later terminated leaving air-to-air missiles as the AIM-9 Sidewinder, AIM-54 Phoenix and AIM-7 Sparrow.

Starting in 2005, some F-14Ds received the ROVER III upgrade allowing eyes in the sky at home or in the Command Post.

The aircraft also proved an outstanding Strike Fighter employing a capability present from the initial design work, but rarely employed. At peak employment, thirty Navy squadrons Tomcats flew combat missions during the Gulf War and in missions over Iraq and Afghanistan from 2001 until the F-14's retirement in 2006.

As an air-to-ground platform, the Tomcat is capable of deploying an large array of air-to-ground ordnance (Mk.80 bombs, LGBs and JDAM) in various configurations, while simultaneously carrying the AIM-7, AIM-9 and AIM-54 air-to-air missiles. The F-14D also carries the LANTIRN targeting system that allows delivery of various laser-guided bombs for precision strikes in air-to-ground combat missions and for battle damage assessment. With its Fast Tactical Imagery (FTI) system the Tomcat can transmit and receive targeting/reconnaissance imagery in-flight to provide time sensitive strike capability. This F-14D is also capable of carrying the Tactical Air Reconnaissance Pod System (TARPS) providing in-theater tactical reconnaissance.

該機是由美國格魯曼公司研製的一款第三代雙發可變後掠翼重型戰鬥機。其D改型相較A型升級為F-110發動機使其擁有更高的推重比和更長的滯空時間，升級了航電系統並用更新的AN/APG-71雷達取代了AWG-9雷達，機鼻在保持優秀制空能力前提下F-14D升級了對地攻擊能力。該機可以掛載藍盾吊艙進行精確對地偵查/攻擊任務。

美海軍共裝備50餘架F-14D型戰鬥機。其中18架F-14A型升級為D型，剩餘則為新製造的戰鬥機。第1架F-14D於1990年2月交付，全部配備了Tape115B電腦軟體。具有用常規炸彈，衛星制導炸彈，鐳射制導炸彈執行對地攻擊任務的能力，並在海灣戰爭中發揮重要作用。

F-14戰鬥機於1970年12月21日原型機首飛。在2006年9月22日，F-14戰鬥機正式退役。除伊朗擁有少量可用的雄貓外，該戰機已從美軍全部退役。但因其擁有鮮明的時代特徵和不俗的戰力，至今仍是眾多軍事愛好者津津樂道的話題。



- ★ 產品不適合8歲以下的兒童。
- ★ 產品中含有帶尖點的小零件。
- ★ 對於3歲以下兒童當心因窒息產生的危害。

NOT SUITABLE FOR CHILDREN UNDER 8 YEARS. CONTAINS FUNCTIONAL SHARP POINTS. CONTAINS SMALL PARTS. BEWARE OF CHOKING HAZARD OF CHILDREN UNDER 3 YEARS.

## PAINT AND COLOR USED

1	白色 White	2	透明紅色 Clear Red	3	啞光黑色 Flat Black
4	紅色 Red	5	透明藍色 Clear Blue	6	灰色的白色 Grayish White
7	黃色 Yellow	8	卡其色 Khaki	9	銀色 Silver
10	灰色 Gray	11	燒鐵色 Burnt Iron	12	透明綠色 Clear Green
13	橄欖色 Olive Drab	14	車胎黑色 Tire Black	15	透明黑色 Clear Black

This kit provides a choice of 2 types of markings. Select one before assembly.  
本模型提供2種塗裝，請於組裝前選擇合適的塗裝。

### A F-14D Tomcat BuNo.164603 of VF-31 'Tomcatters'

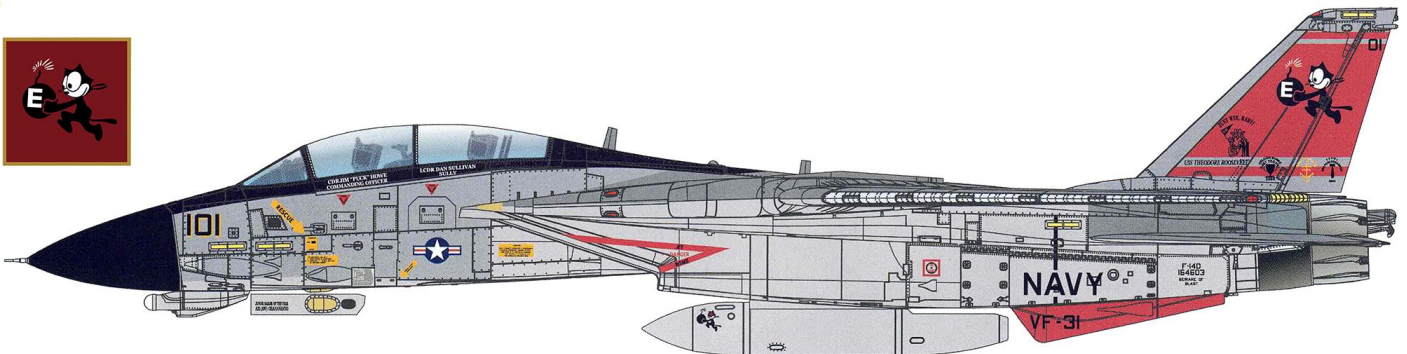

### B F-14D Tomcat BuNo.158985 of VF-2 'Bounty Hunters'

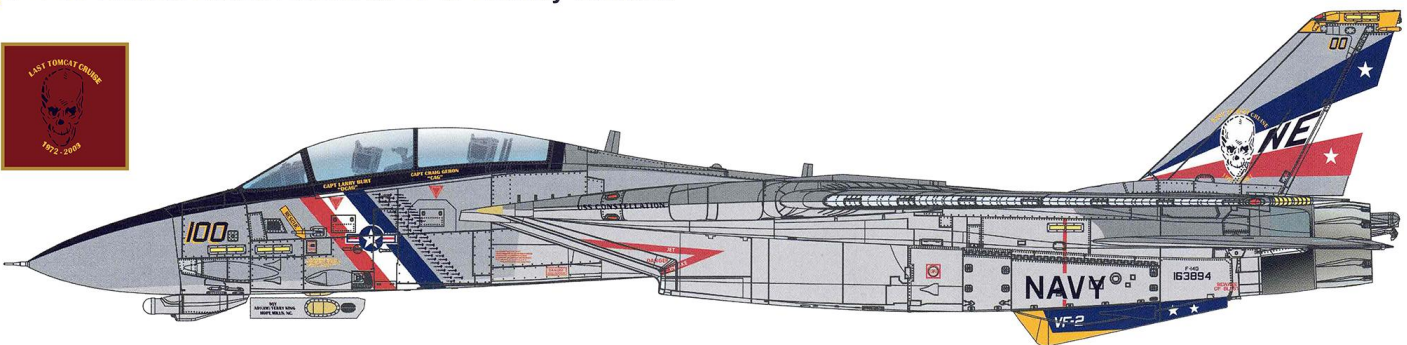
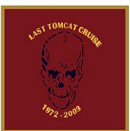

## Drilling Holes

鑽孔

Rear Underfuselage Pallet  
機底後掛架

V24

Front Underfuselage Pallet  
機底前掛架

Rear Underfuselage Pallet  
機底後掛架

V25

Front Underfuselage Pallet  
機底前掛架

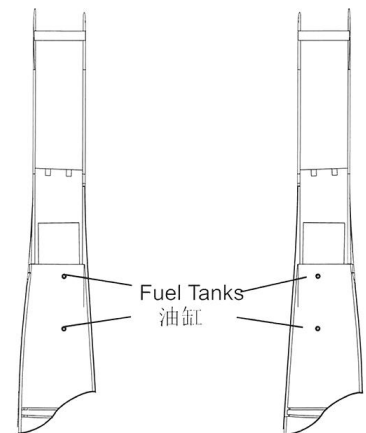

Part E

Part F

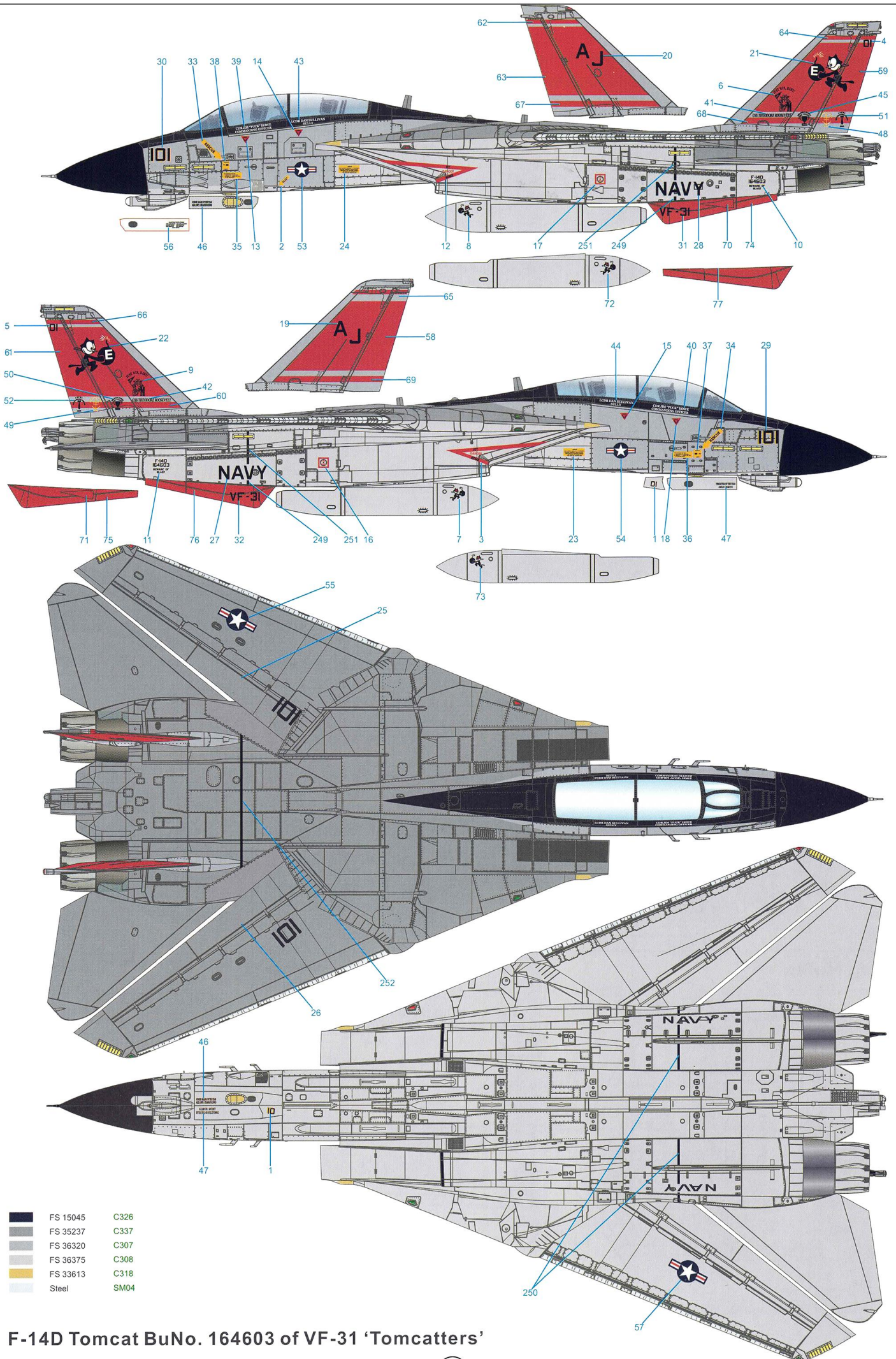

F-14D Tomcat BuNo. 164603 of VF-31 'Tomcatters'

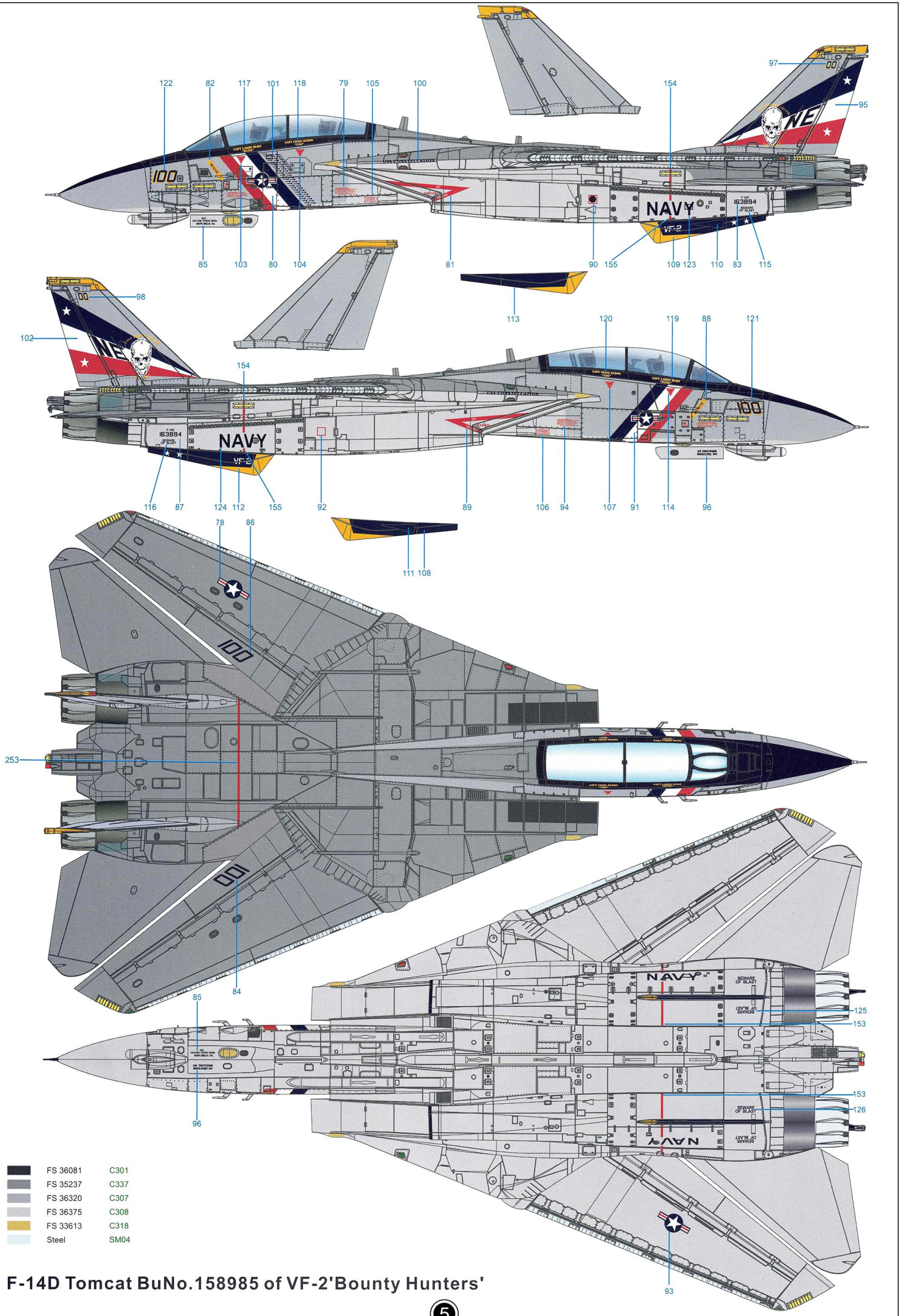

F-14D Tomcat BuNo.158985 of VF-2'Bounty Hunters'

### Stencil data scheme

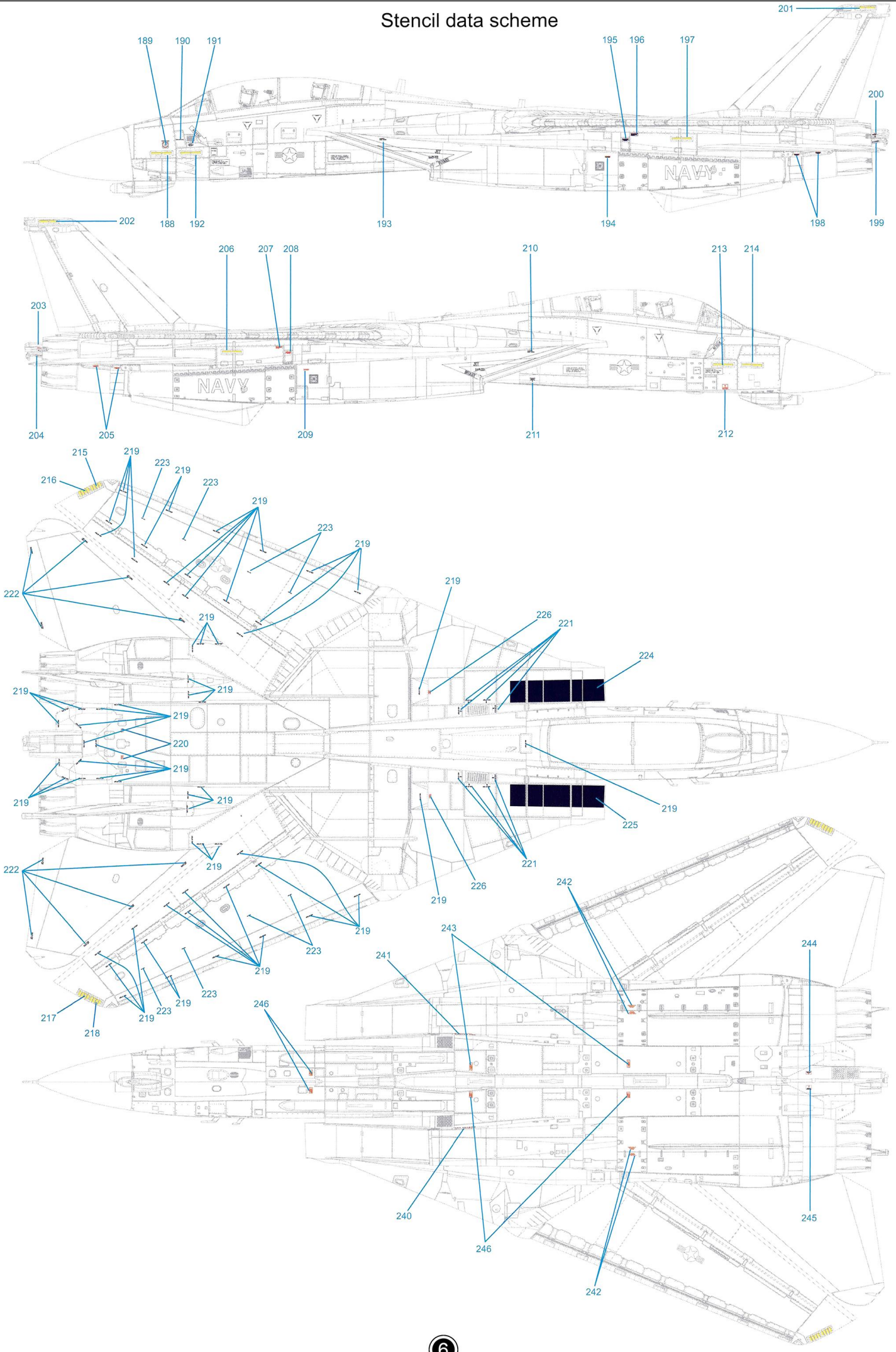

### Front cockpit

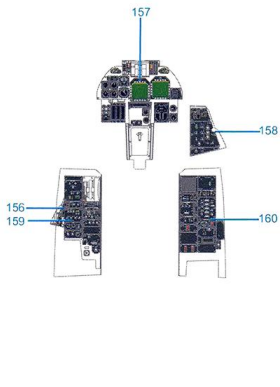

### Aft cockpit

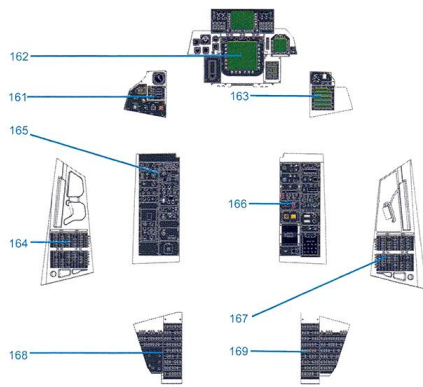

### Ejection seats

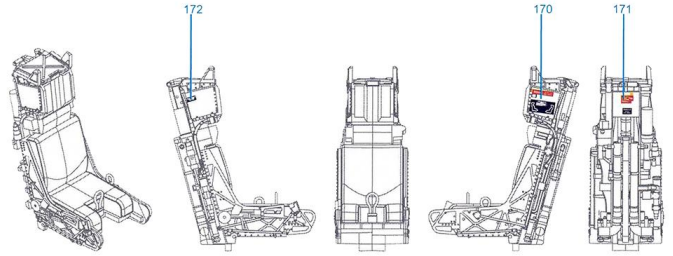

### Pylons, adapters and launchers

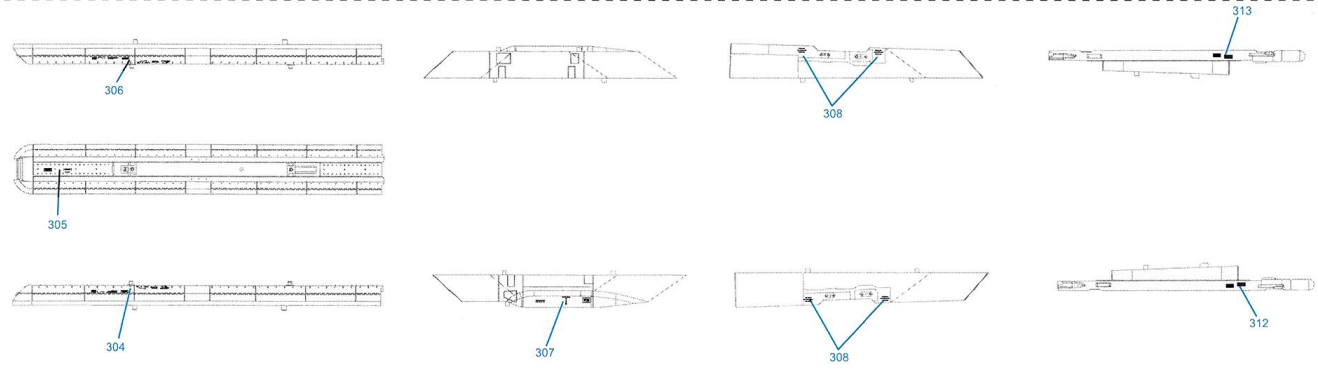
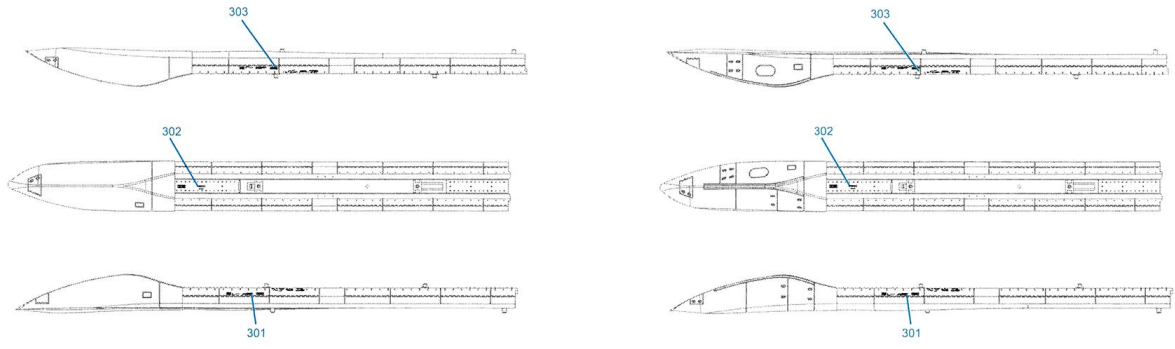

### AIM-54C

### AIM-7M

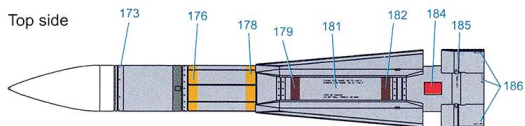
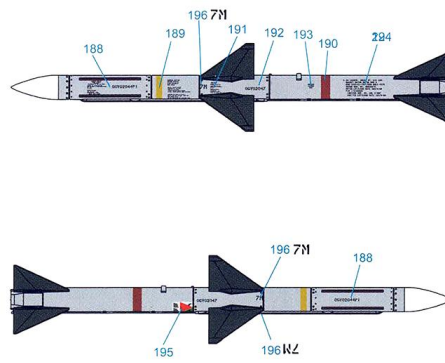
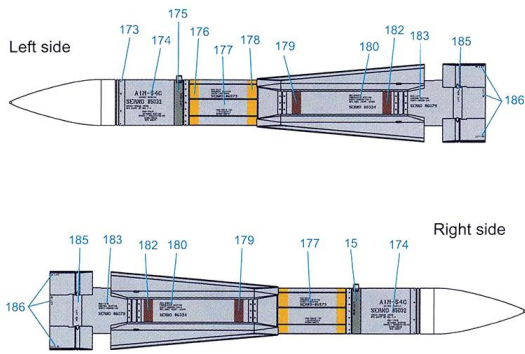

### AIM-9M

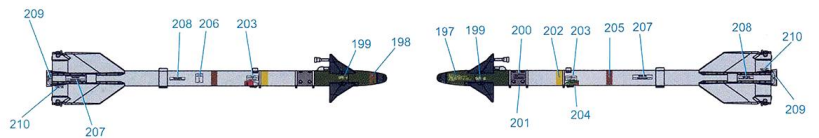

	FS 36375	308
	FS 17875	1
	Stainless	MC213
	FS 34102	303
	FS 34087	304
	FS 36118	305

# 1 Ejection Seats

彈射座椅

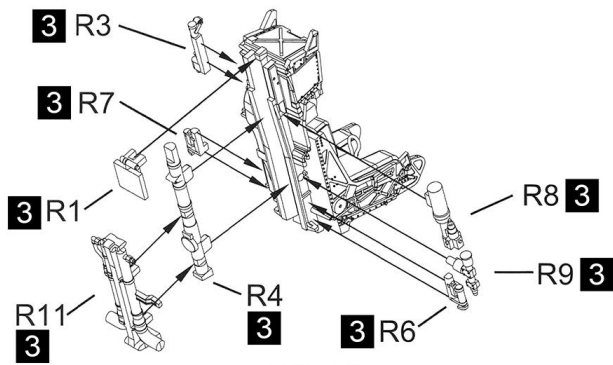
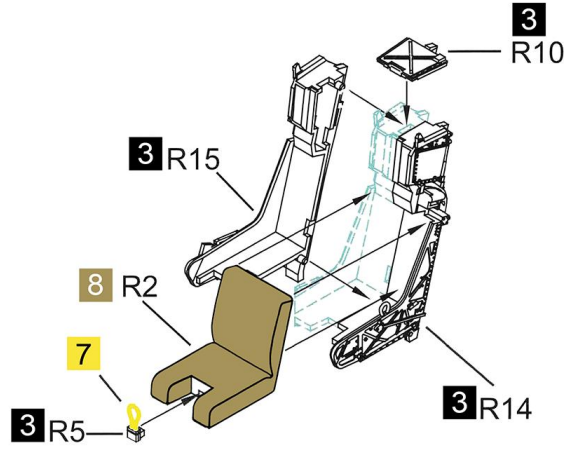
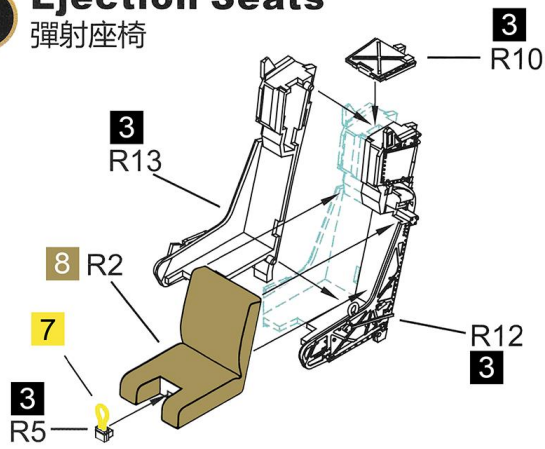

Pilot Seat

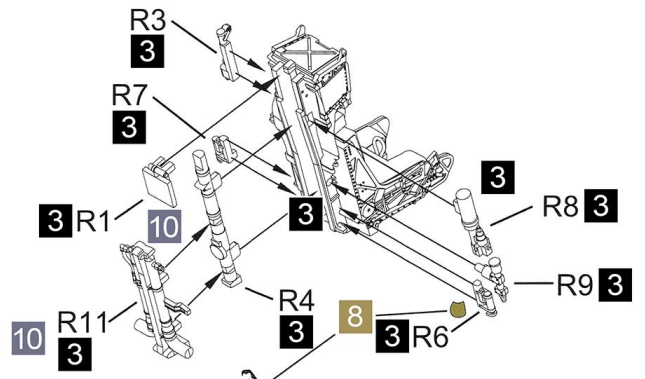

RIO Seat

# 2 Cockpit

座艙

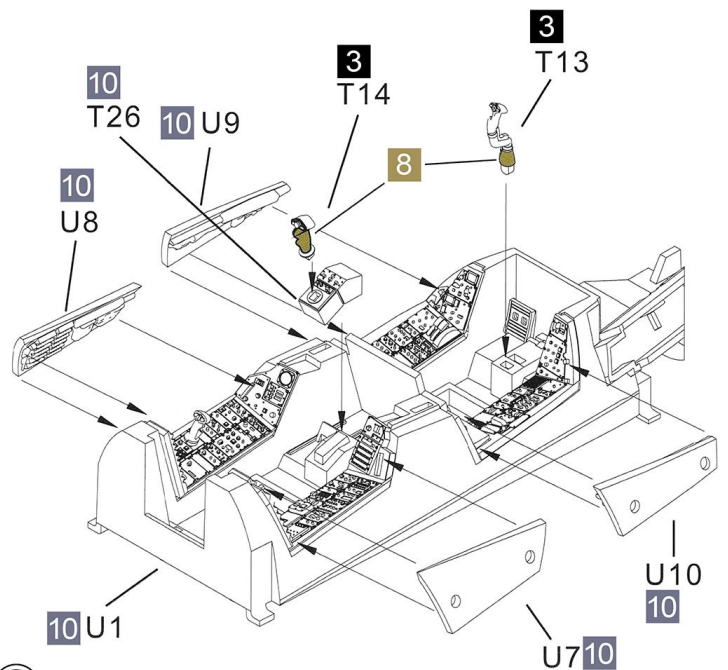
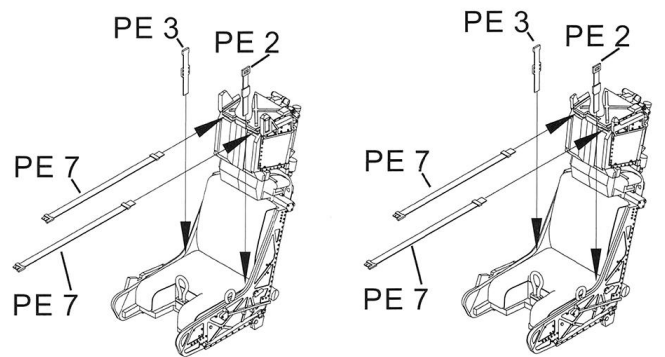
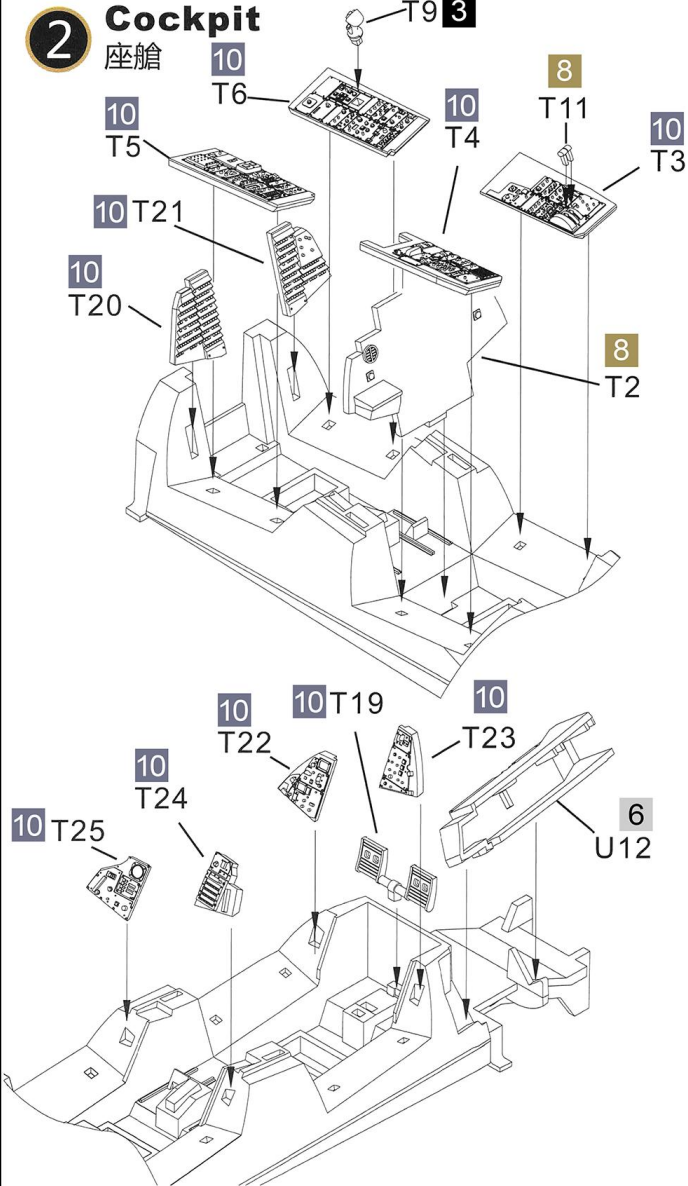



### 3 Front Fuselage 前機身

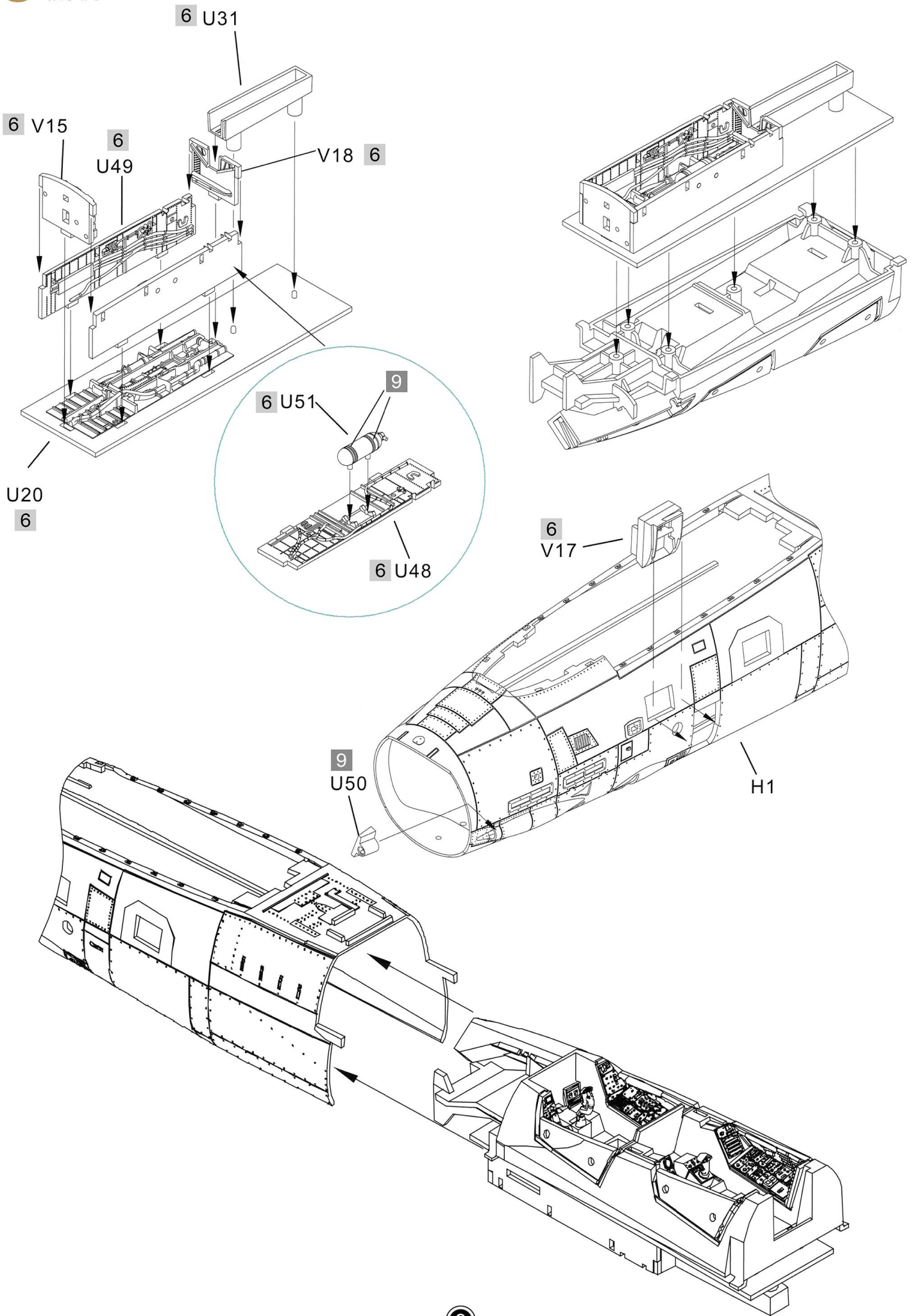



**7 Attaching Intake Ramps**  
組裝氣底壓板

Subsonic Speeds  
亞音速

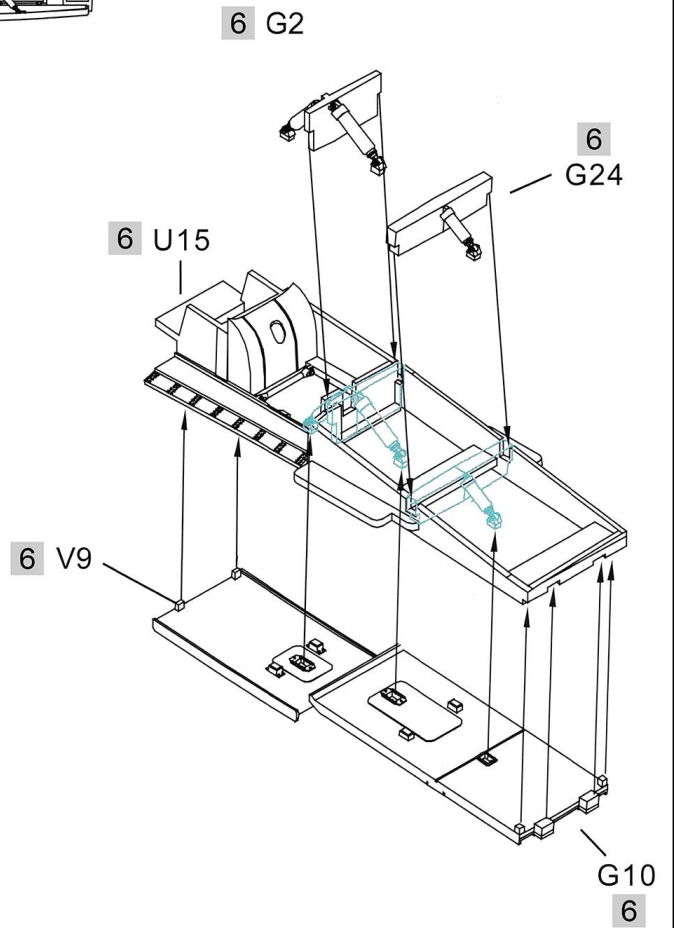
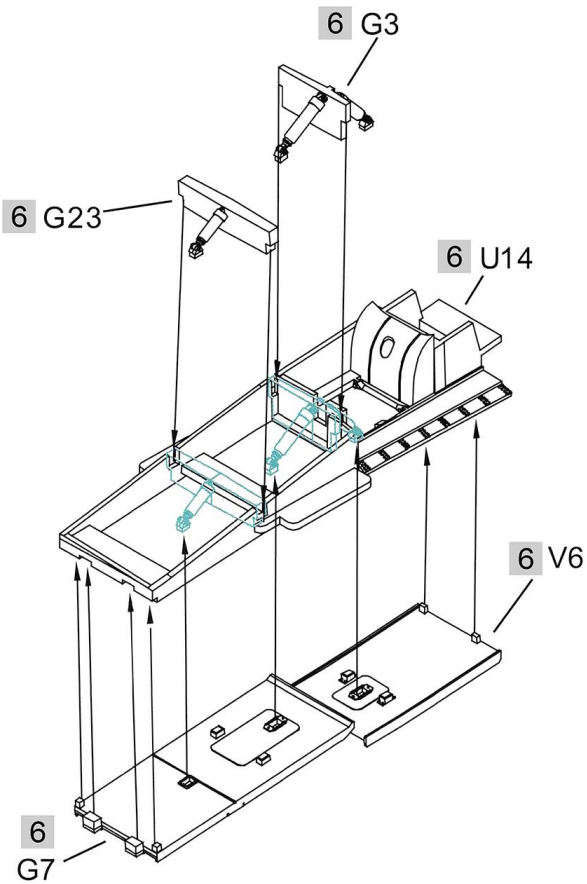
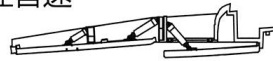

**7 Attaching Intake Ramps**  
組裝氣底壓板

Subsonic Speeds  
跨音速

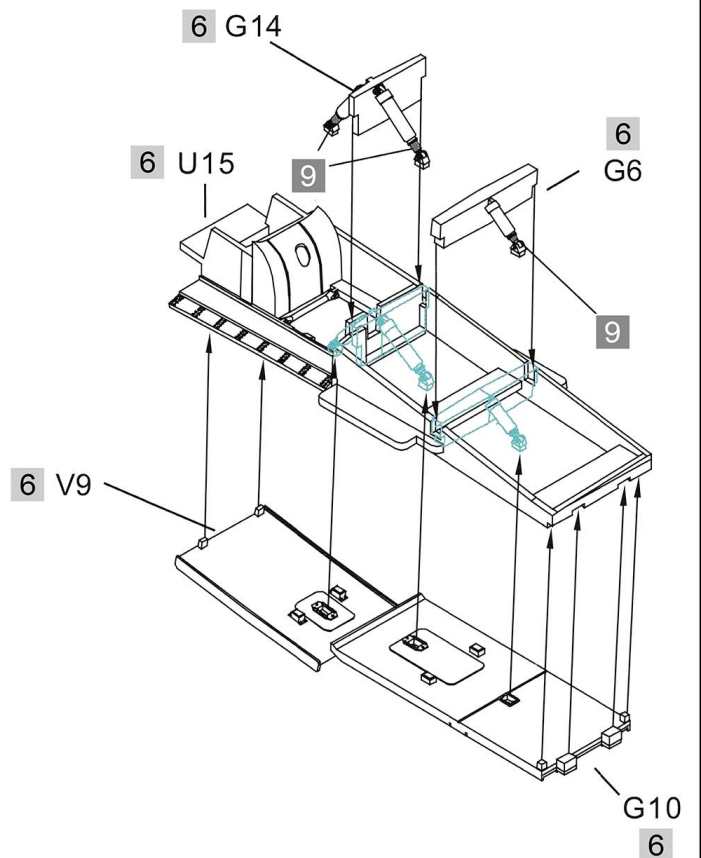
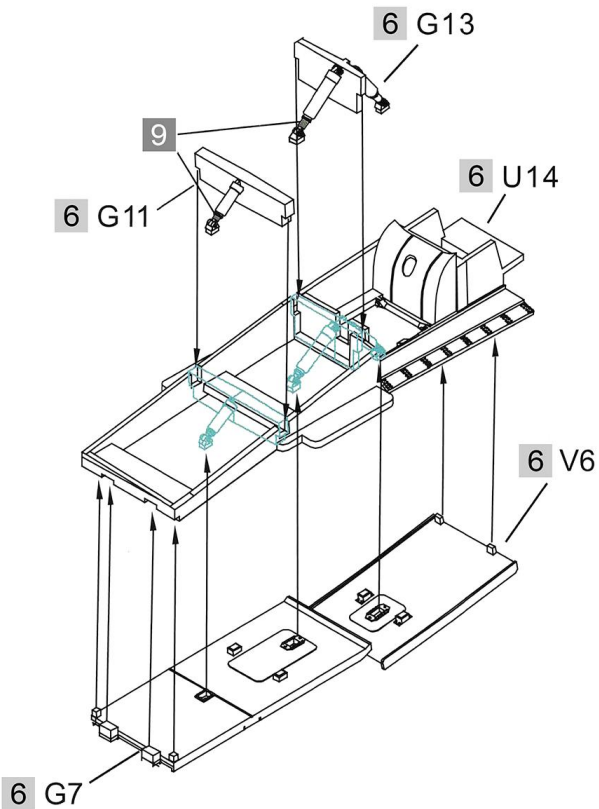

## 7 Attaching Intake Ramps

組裝氣底壓板

Supersonic Speeds  
超音速

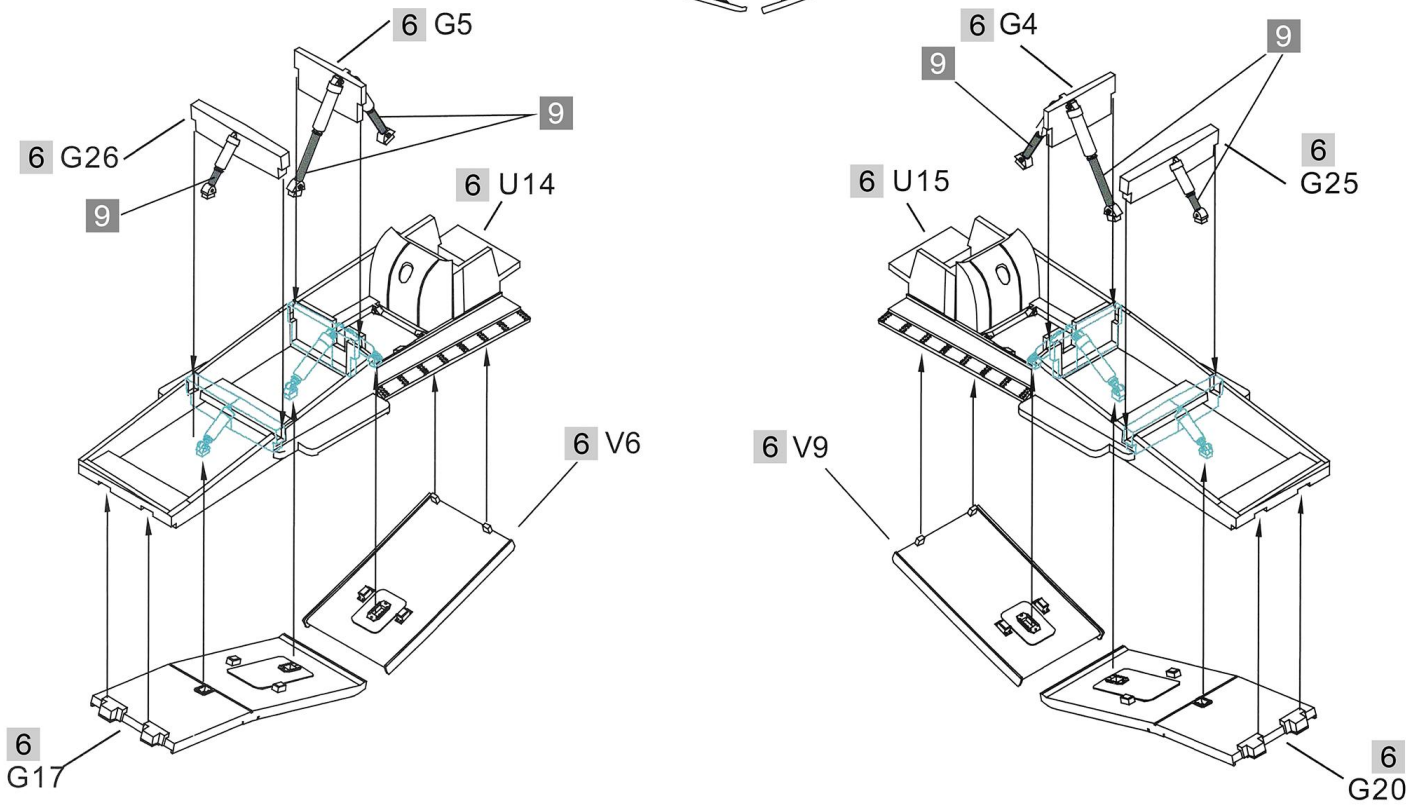

## 8 Attaching Intake Trunks

組裝進氣道

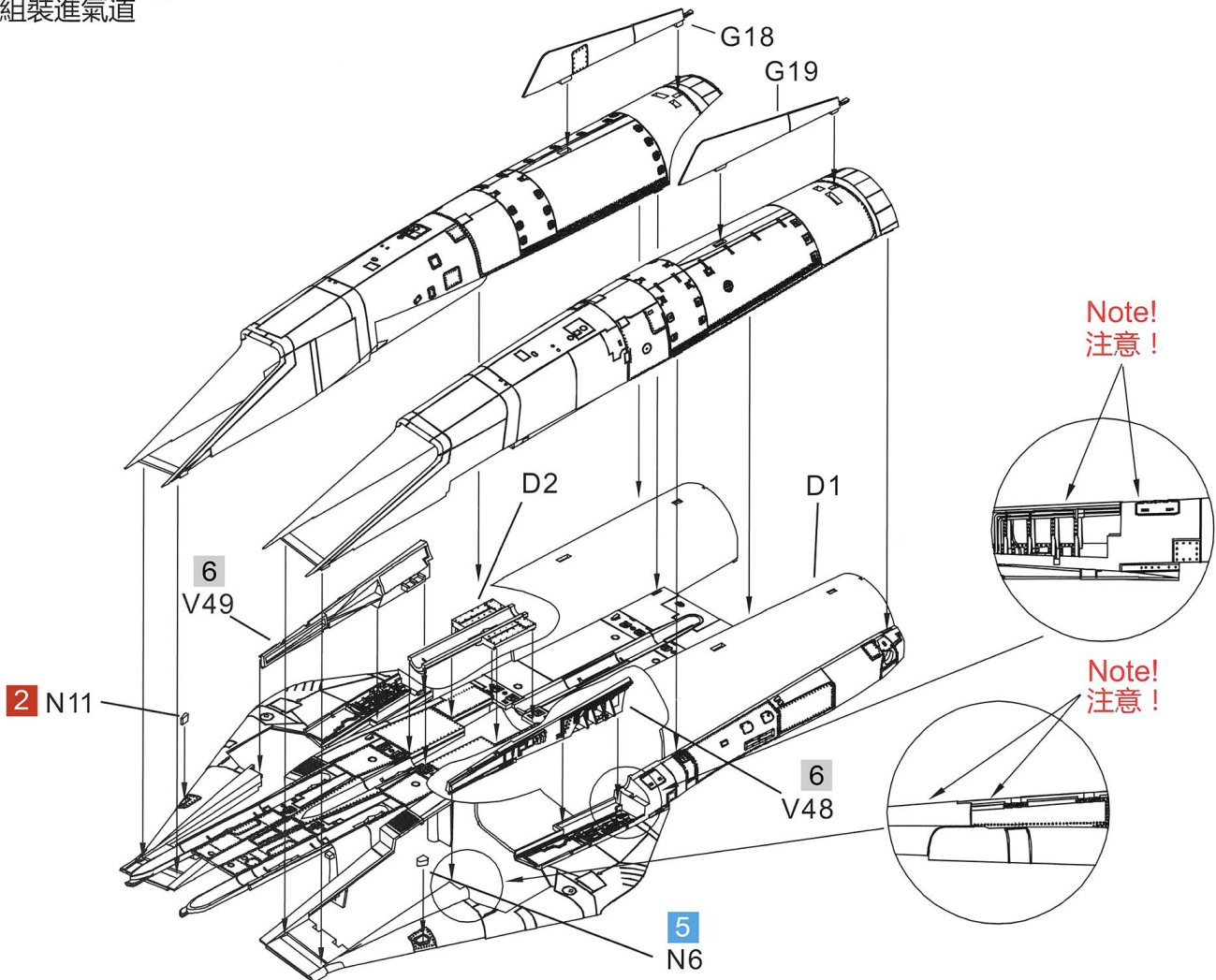

## 9 Horizontal Tail Wing Positions

水平尾翼狀態

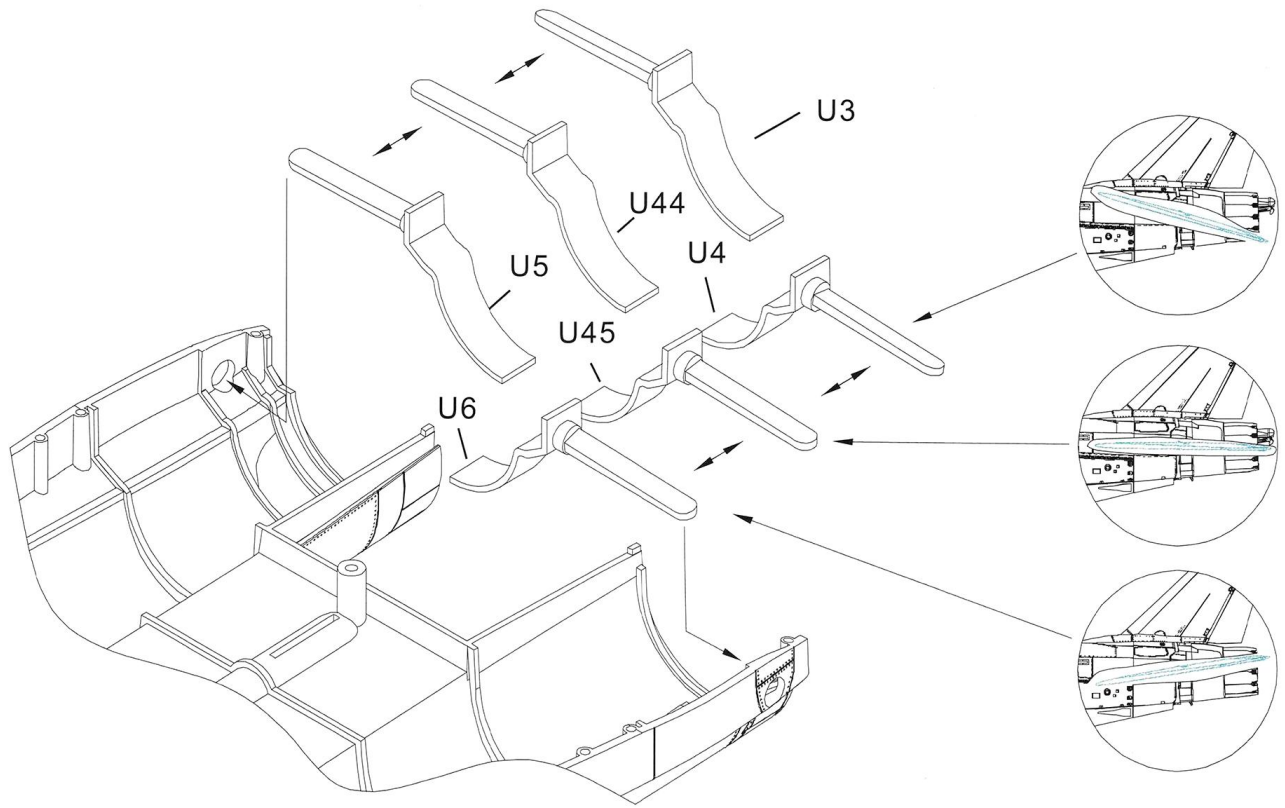

## 10 Attaching Engine, Intake Ramps & Main Landing Gear Bay

組裝引擎，氣流壓板&主起落架艙

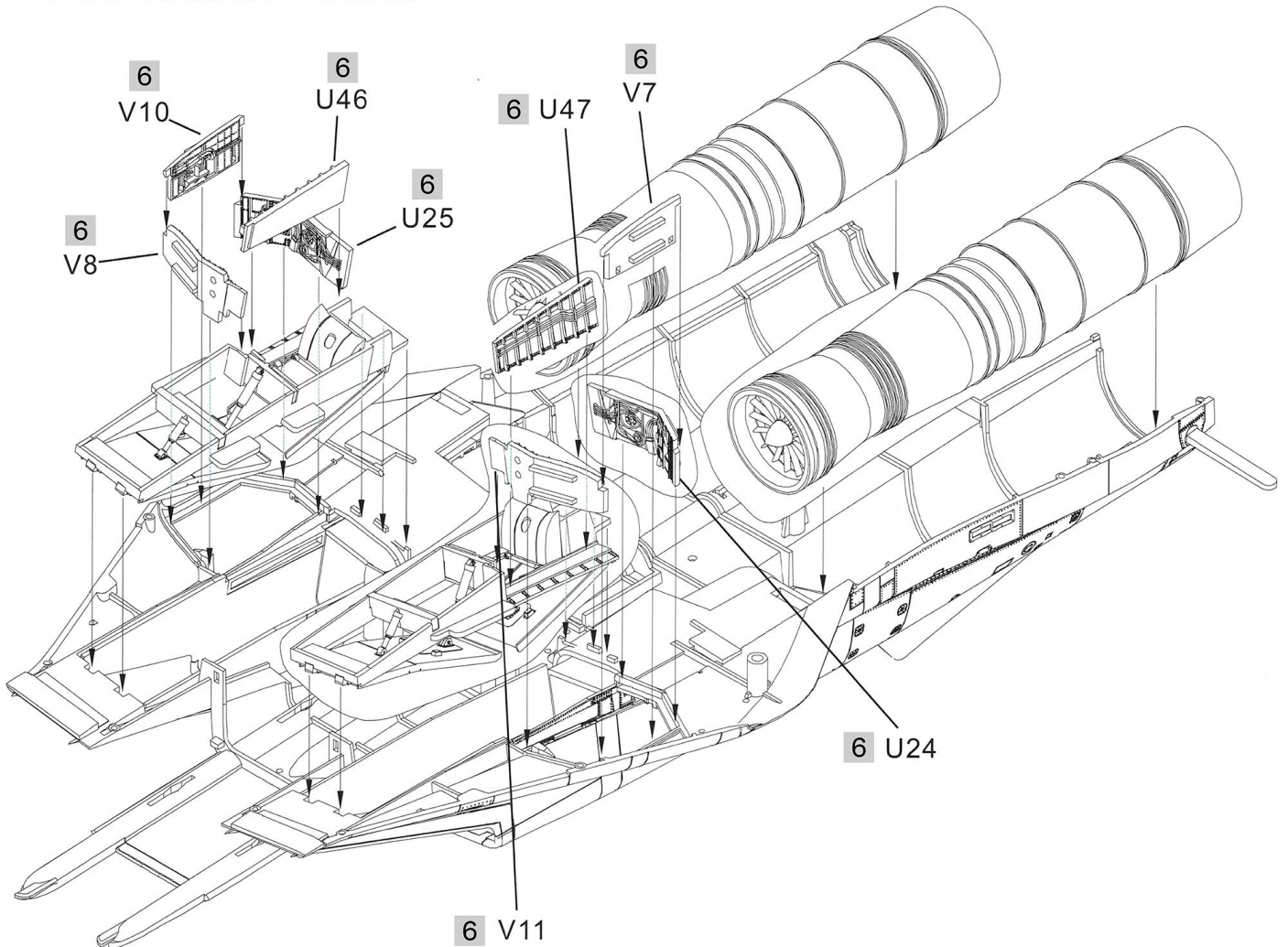

**11 Open Wings**  
打開機翼狀態

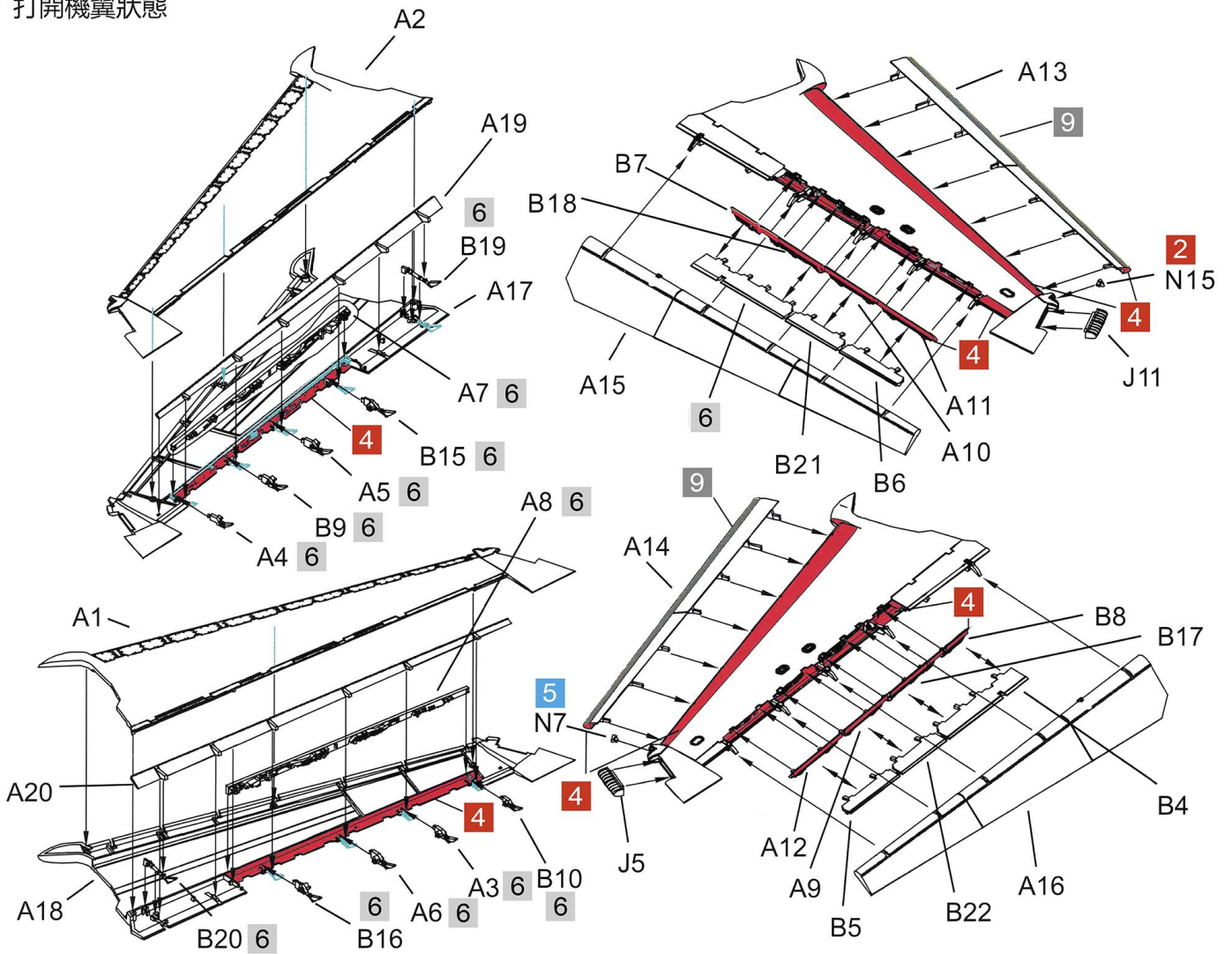

**12 Close Wings**  
關閉機翼狀態

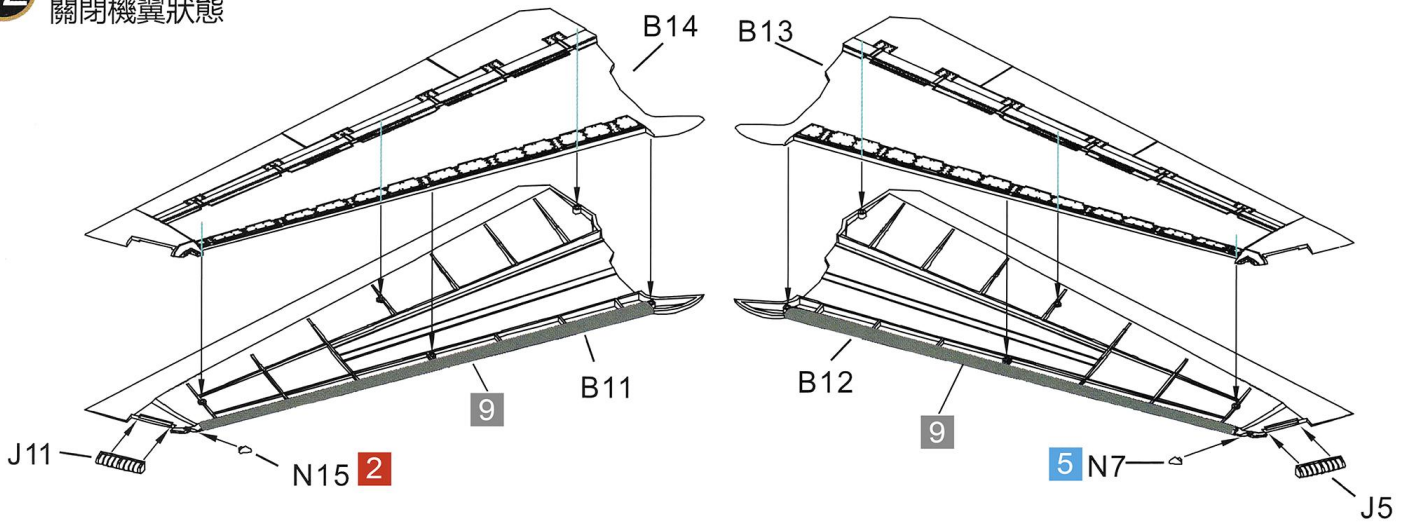

**13 Horizontal Tail Wing&Tail**  
水平尾翼及機尾

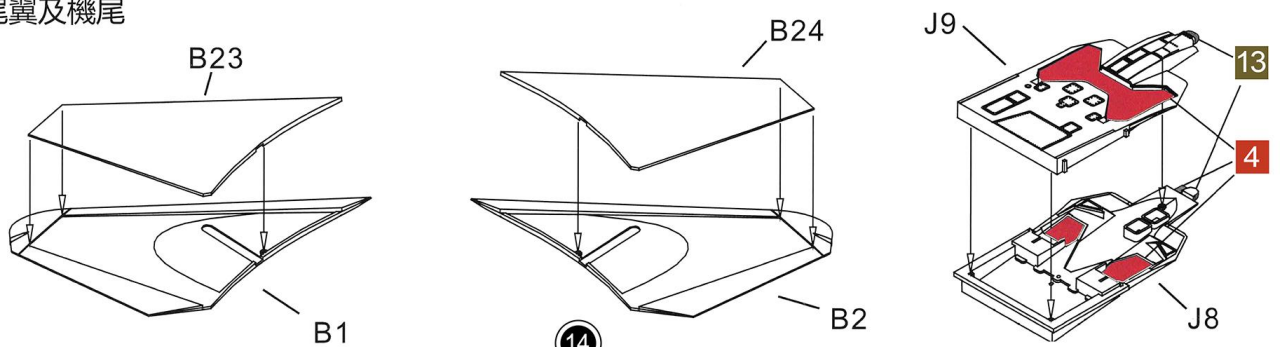

### 13 Attaching Wings

組裝機翼

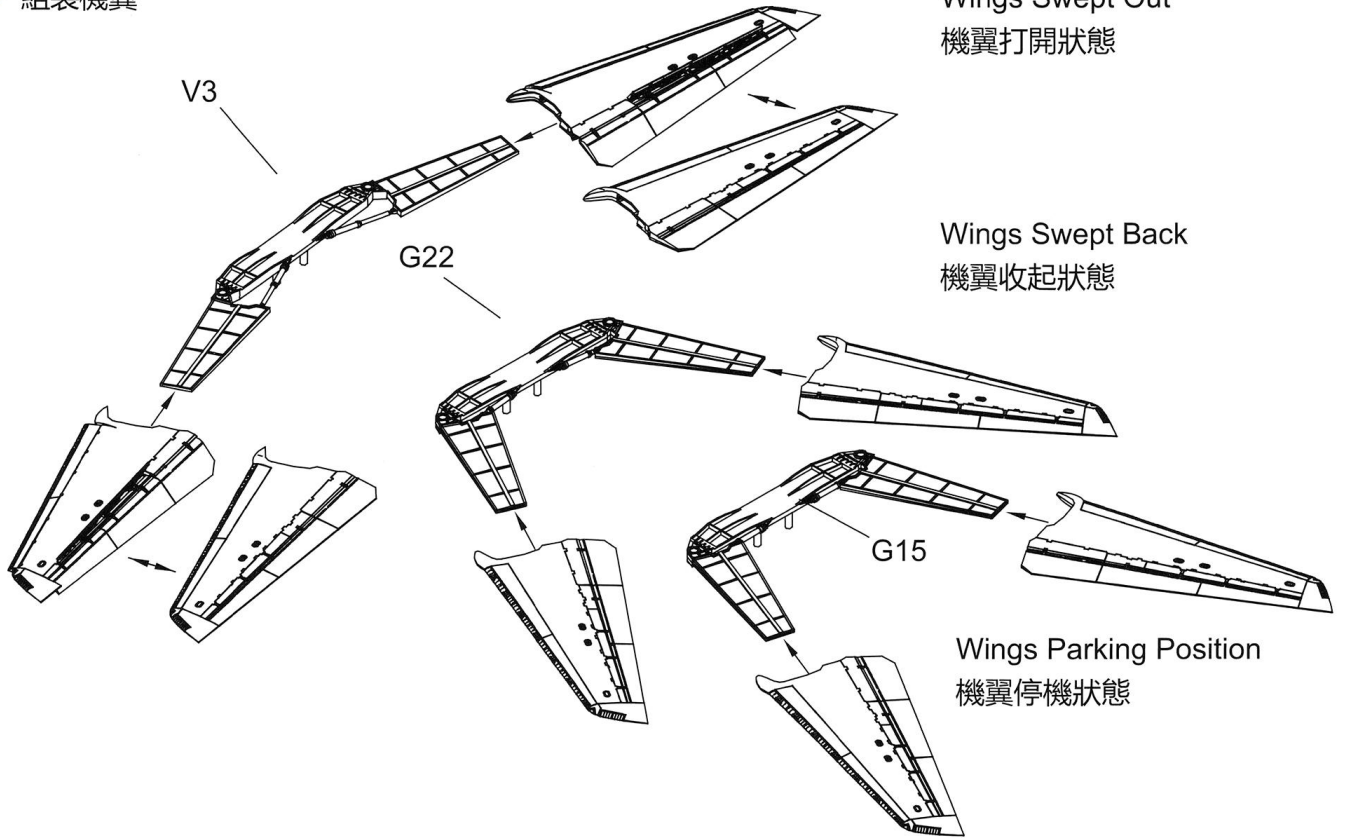

### 14 Top Fuselage

上機身

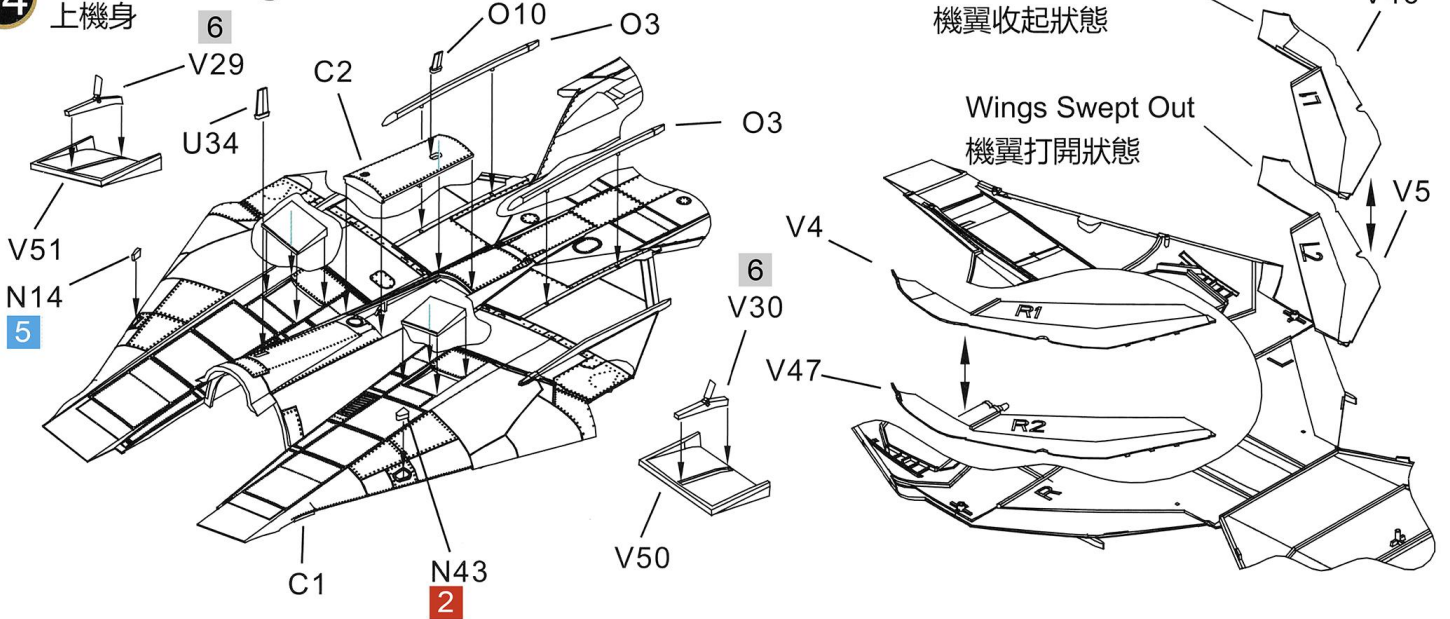

### 15 Vertical Tail Wings

垂直尾翼

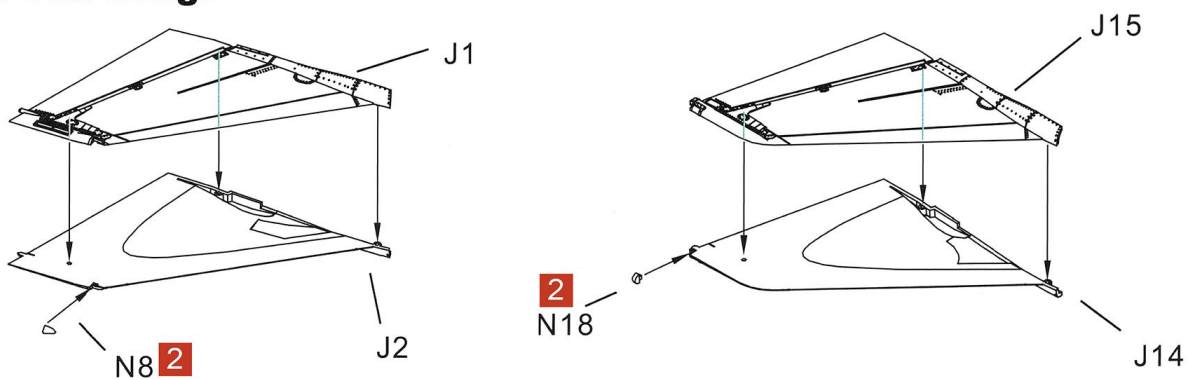

## 16 Closing Fuselage & Attaching Nozzles

組合機身&組裝尾噴口

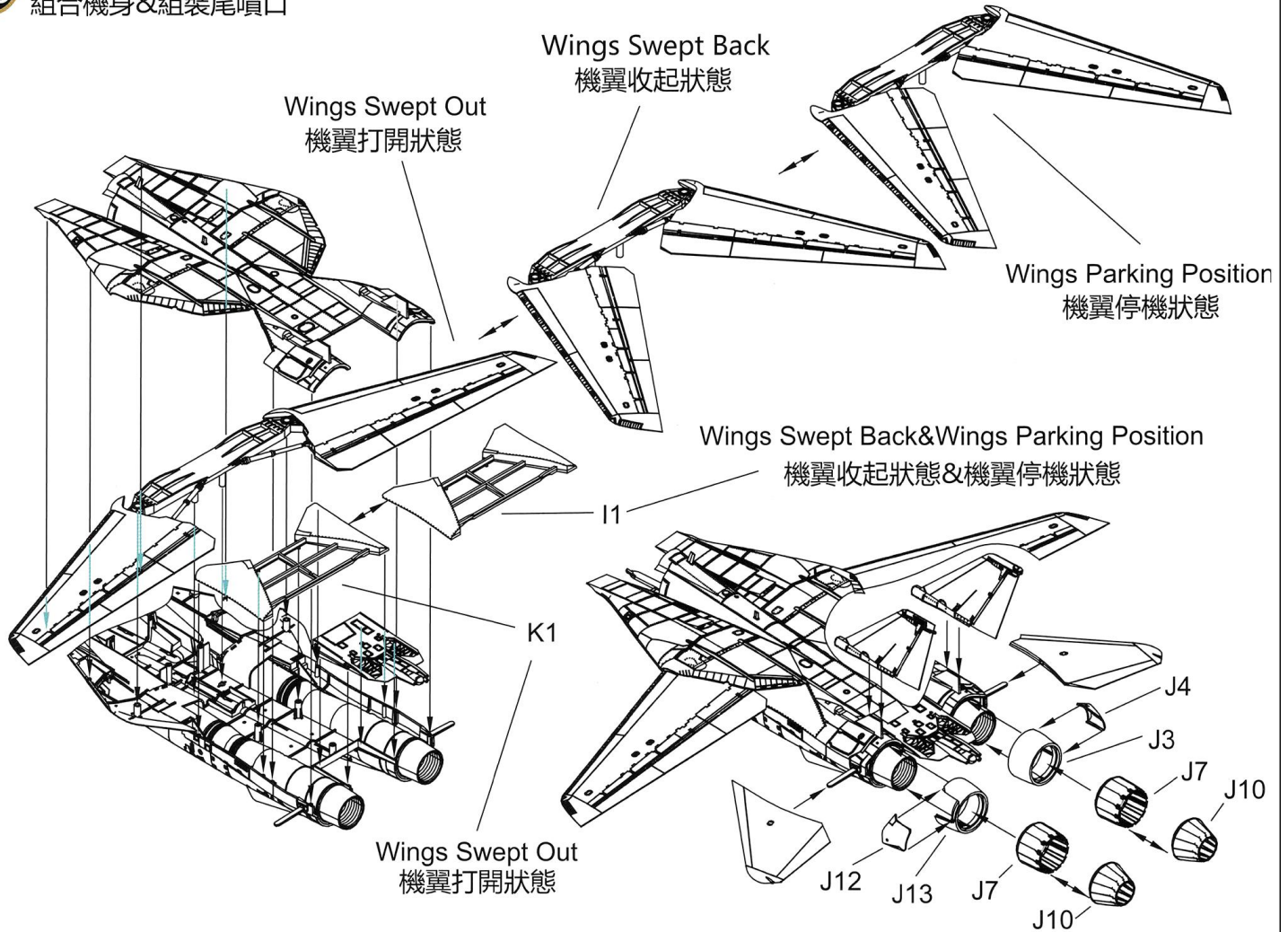

## 17 Front Fuselage

前機身

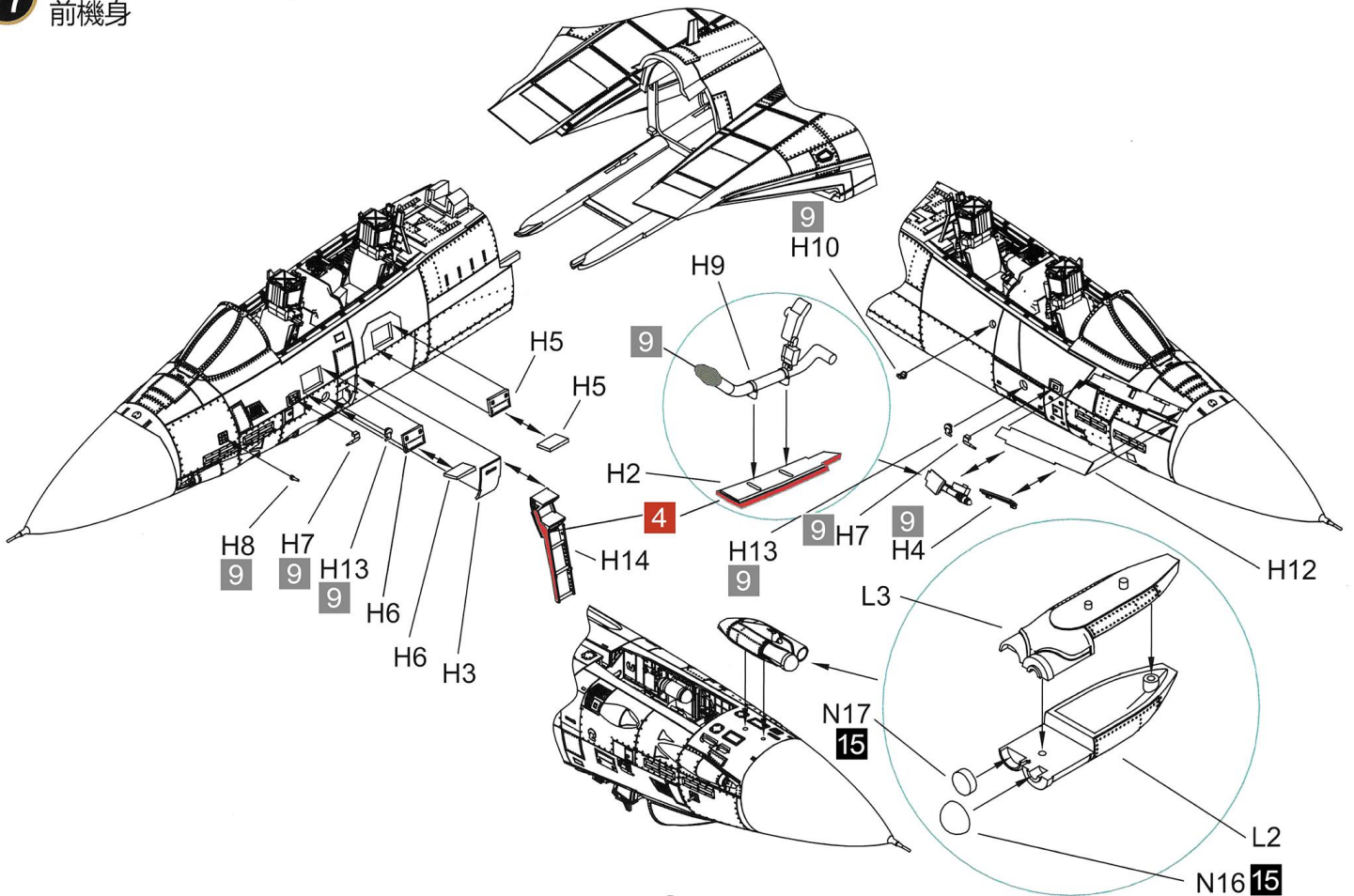



### 18 Front Landing Gear 前起落架

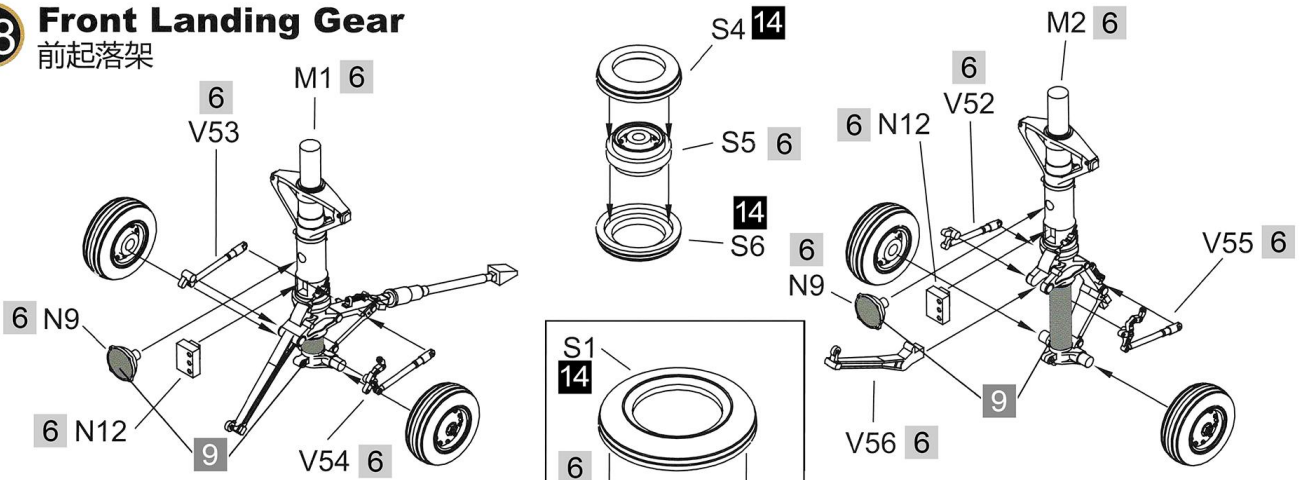

### 19 Main Landing Gears 主起落架

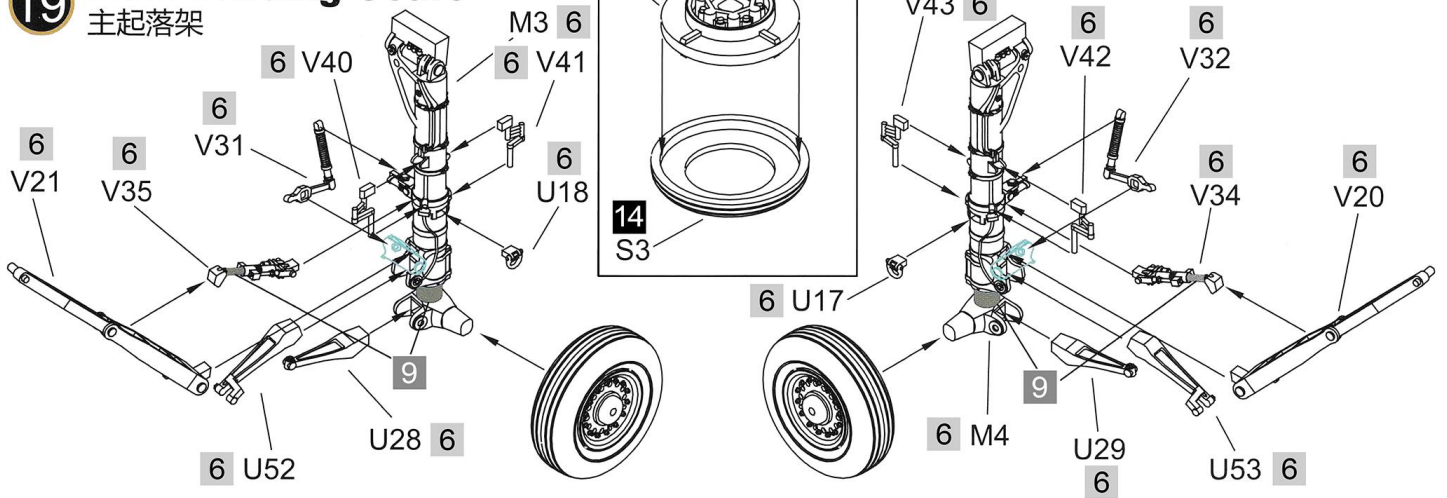

### 20 Attaching Front Landing Gear 組裝前起落架

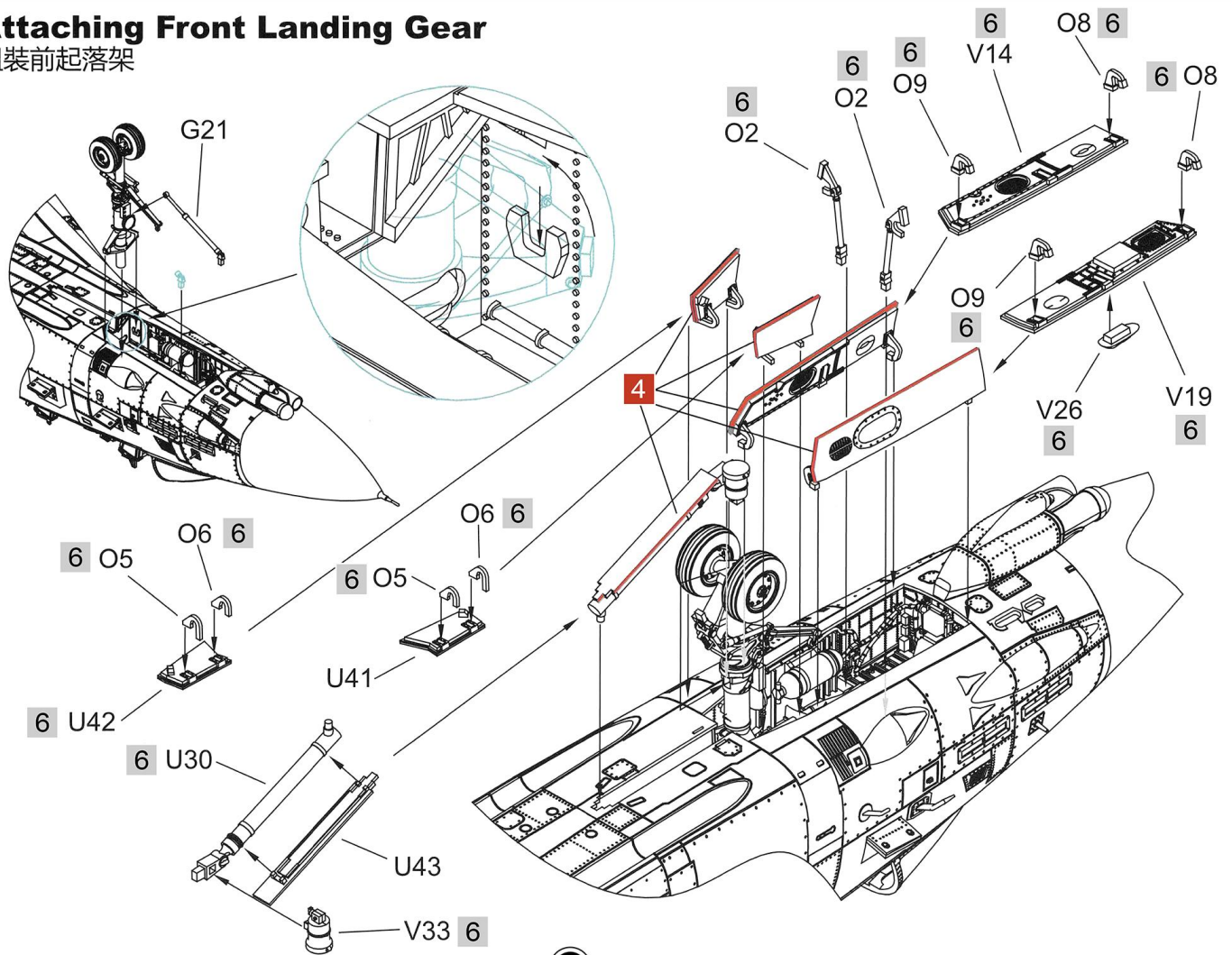

## 21 Attaching Main Landing Gears

組裝主起落架

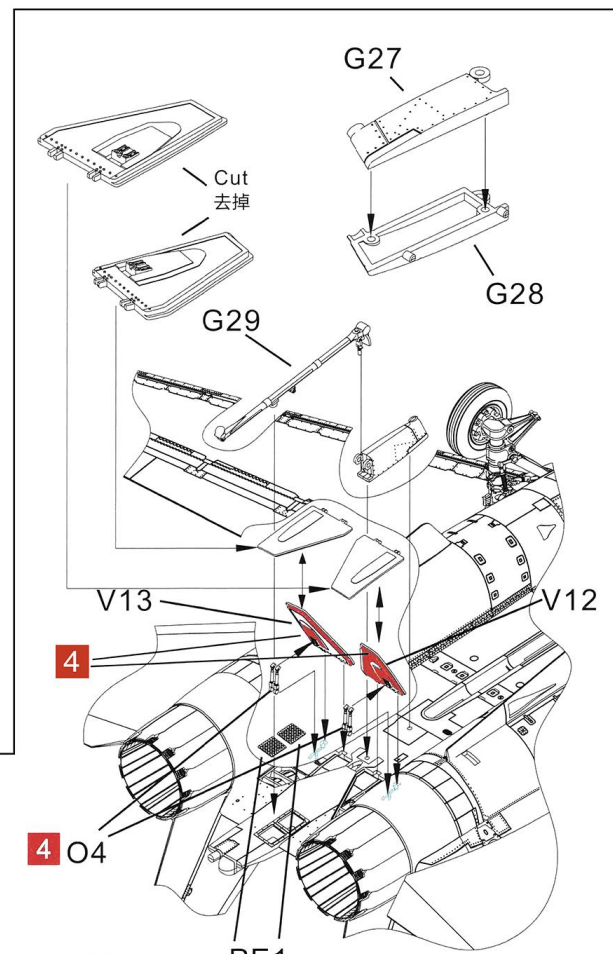
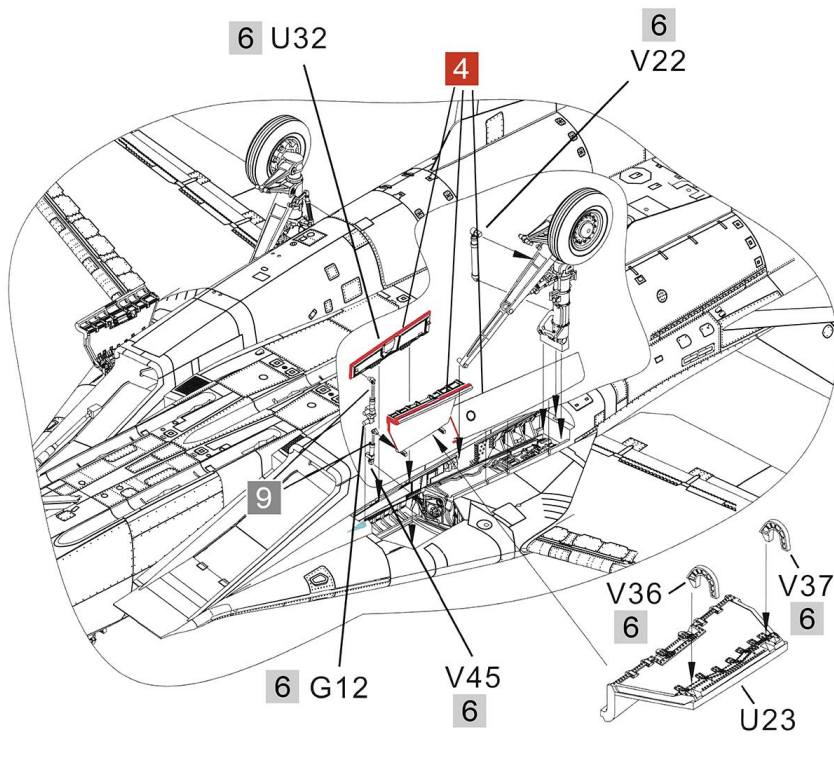
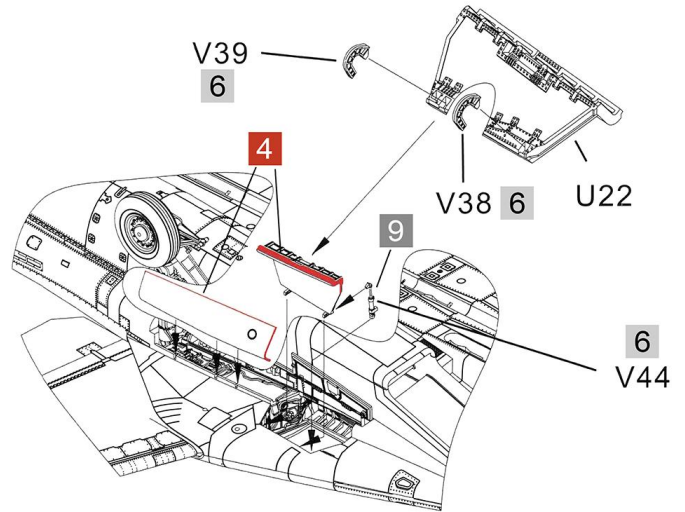
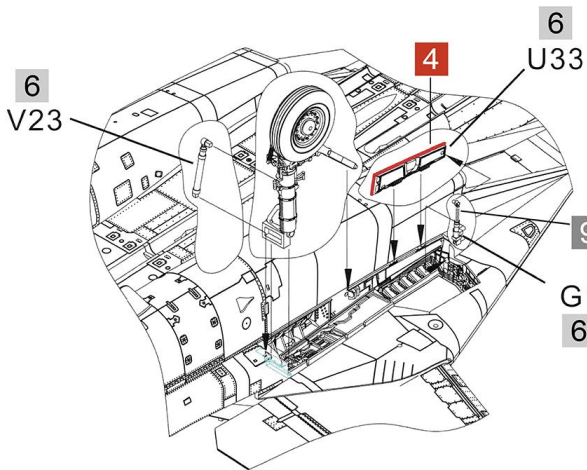

## 22 Attaching Air Brakes

組裝減速板

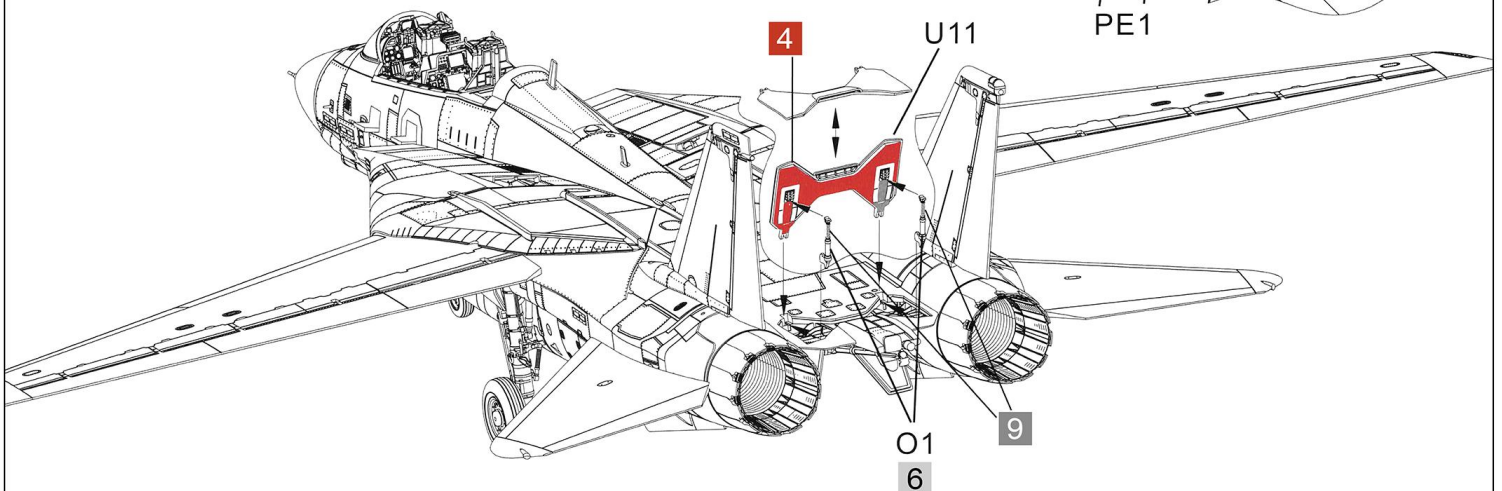

**23** Canopy  
座艙罩

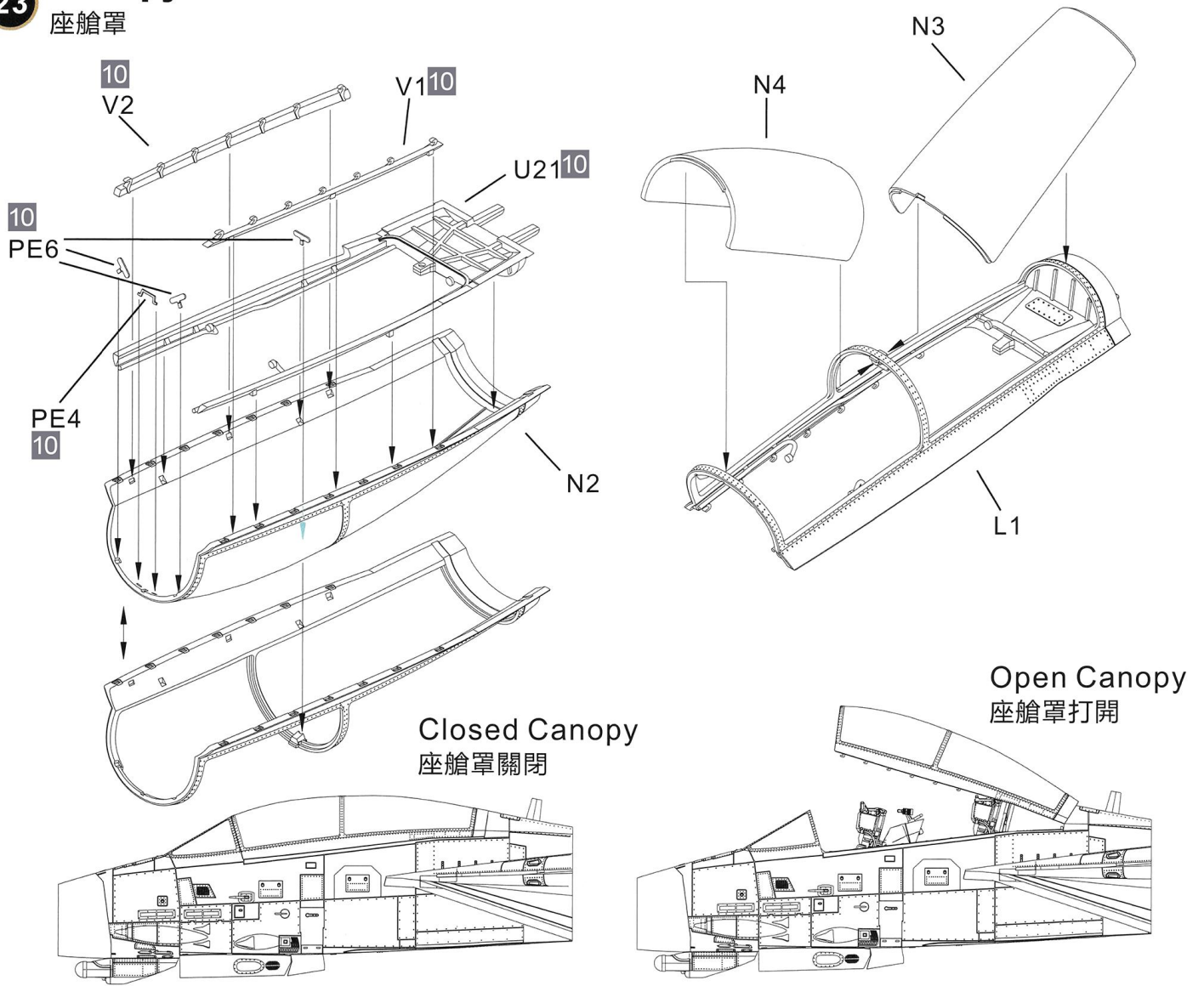

**24** Underfuselage Pallet  
機底掛架

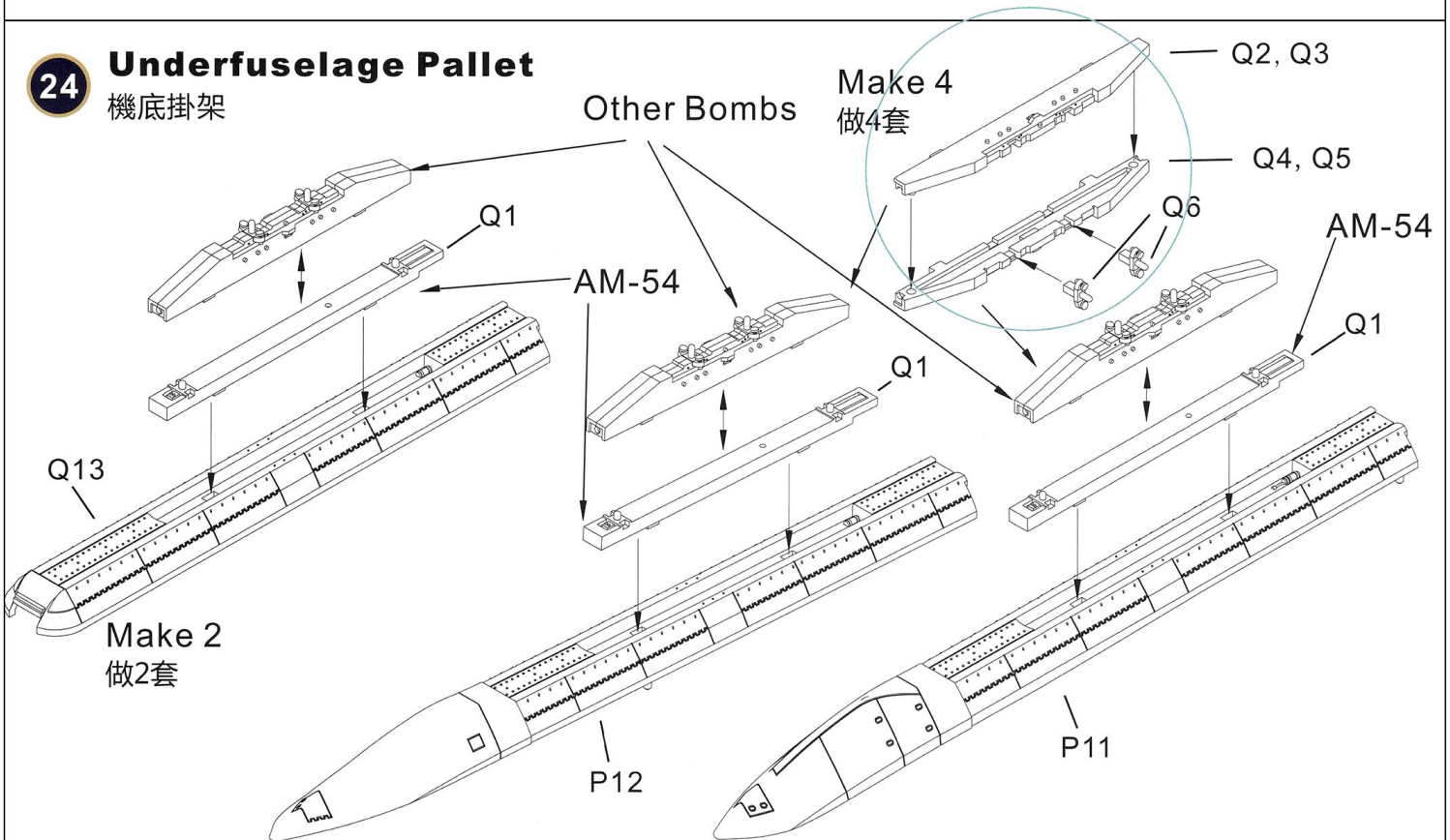

**25 Fuel Tanks**  
油箱

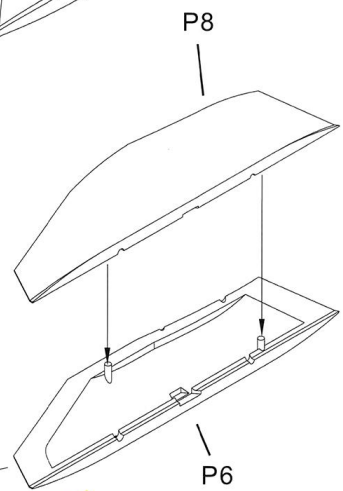
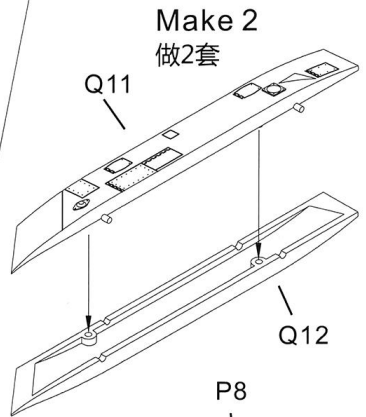
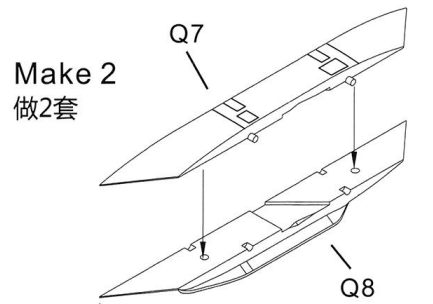
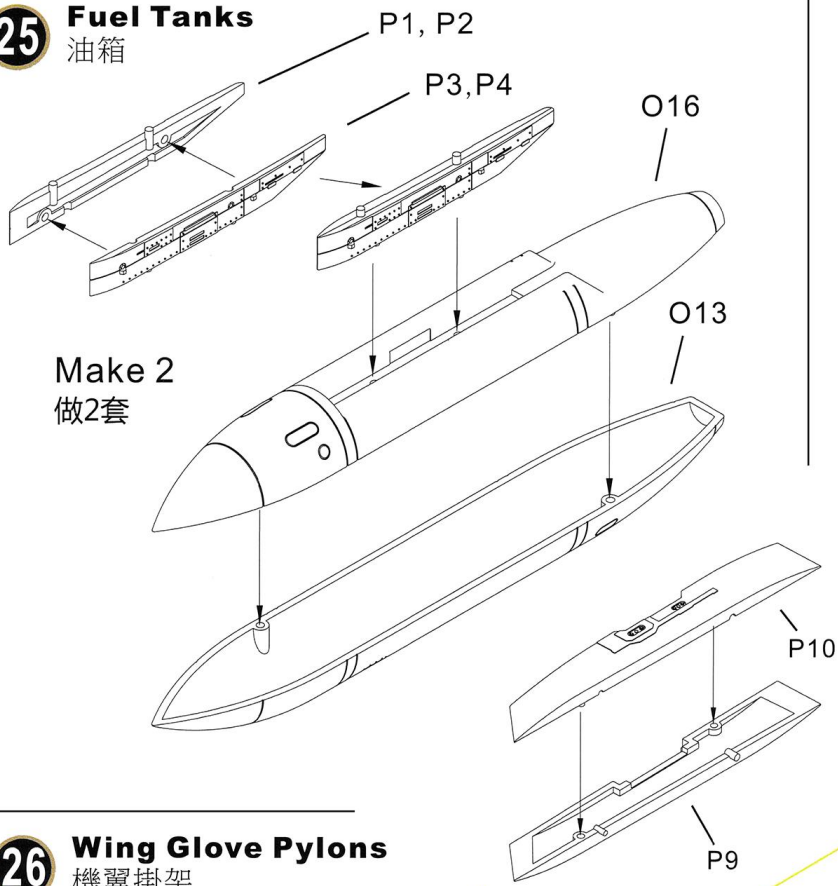

**26 Wing Glove Pyllons**  
機翼掛架

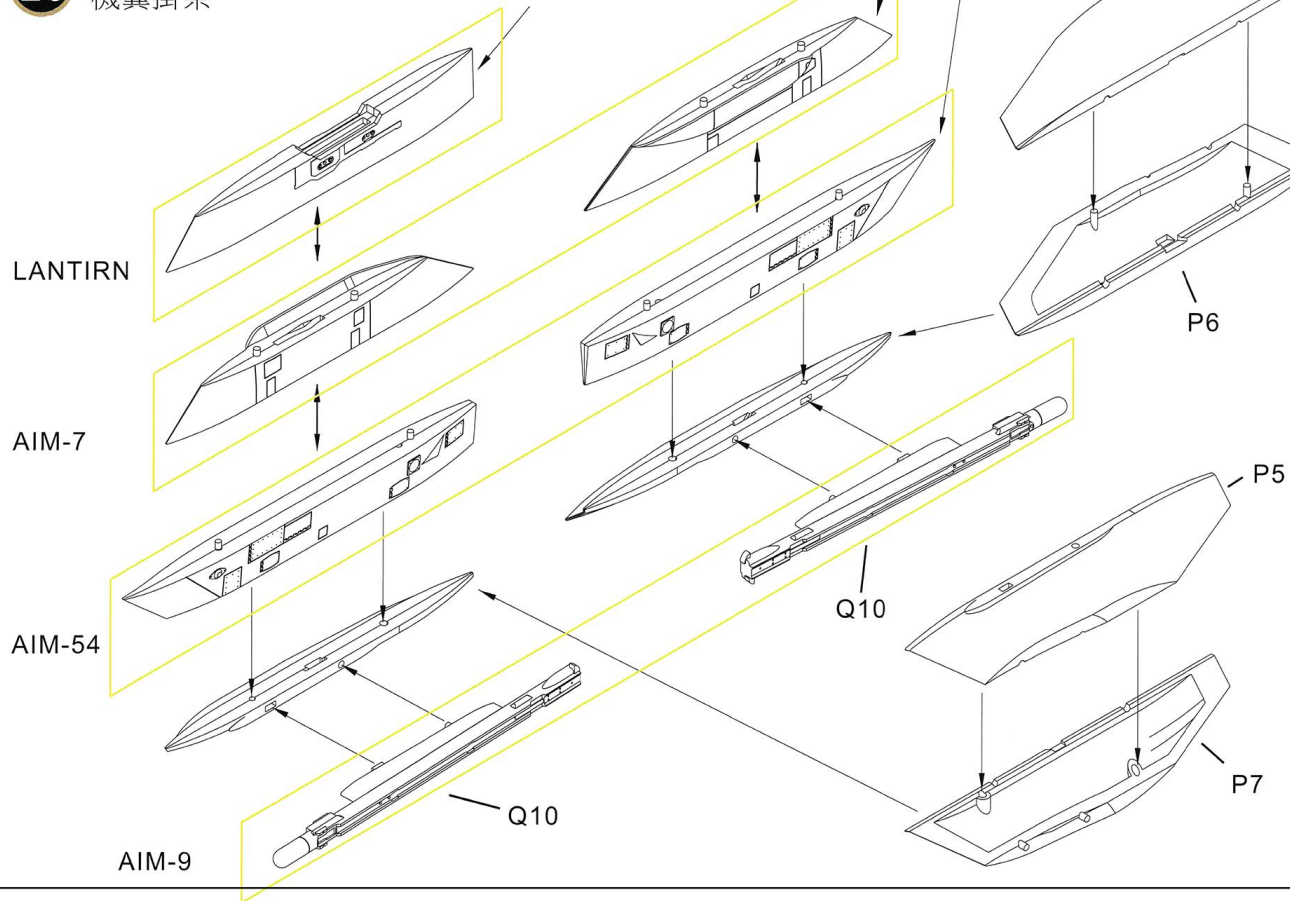

**ZA 08** AIM-54

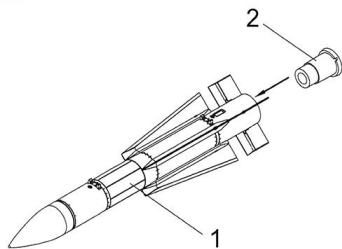

**ZA 09** AIM-7

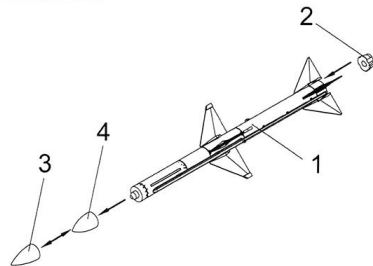

**ZA 10** AIM-9

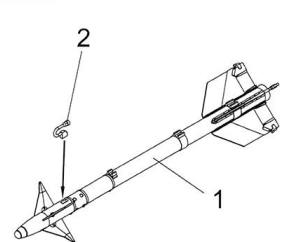

# Weapon Loading

武器掛載

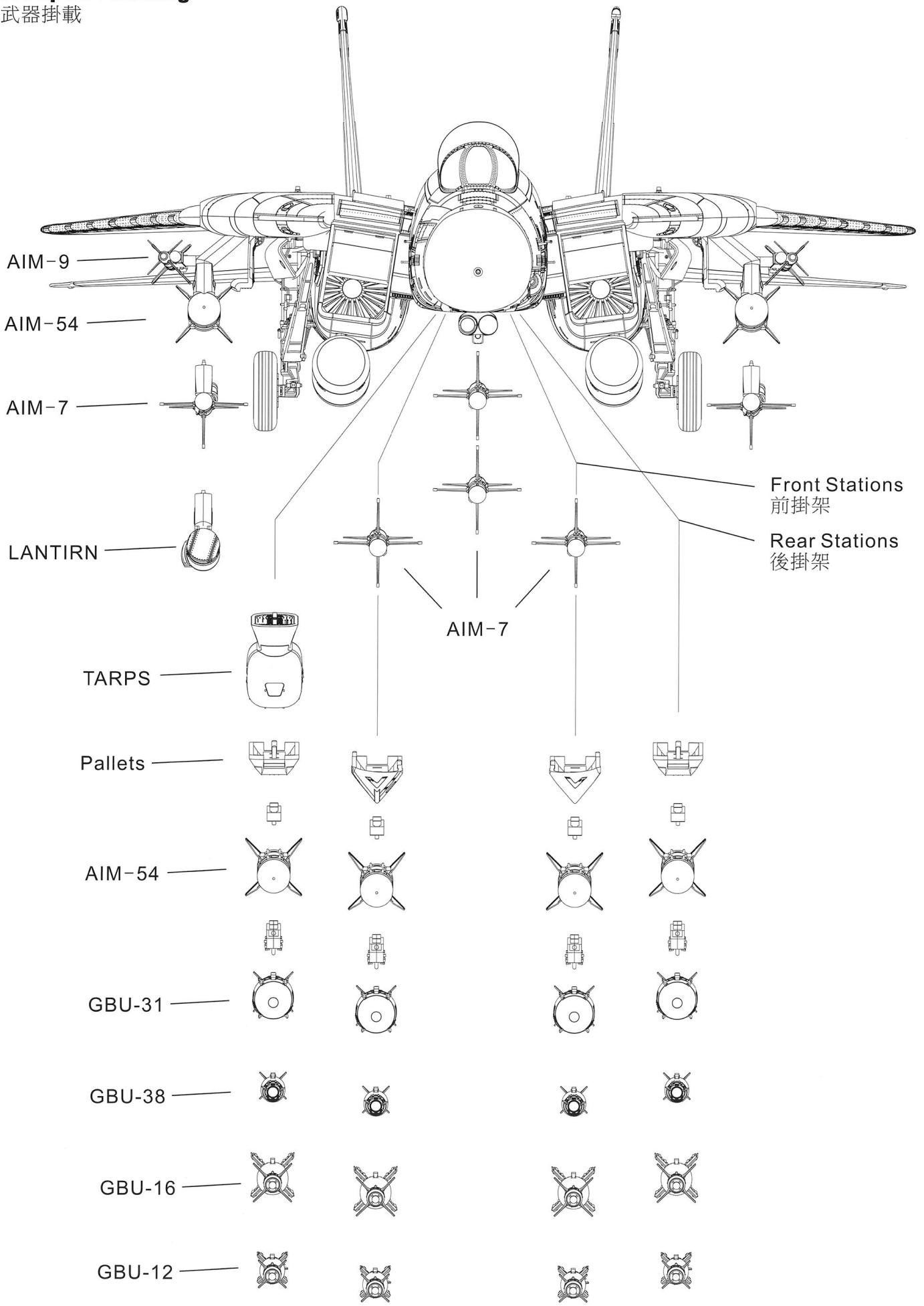

Except AIM-54,  
AIM-7 and AIM-9,  
Other armament  
are NOT included.

# PARTS

**A** PARTS X1  
88A005-01

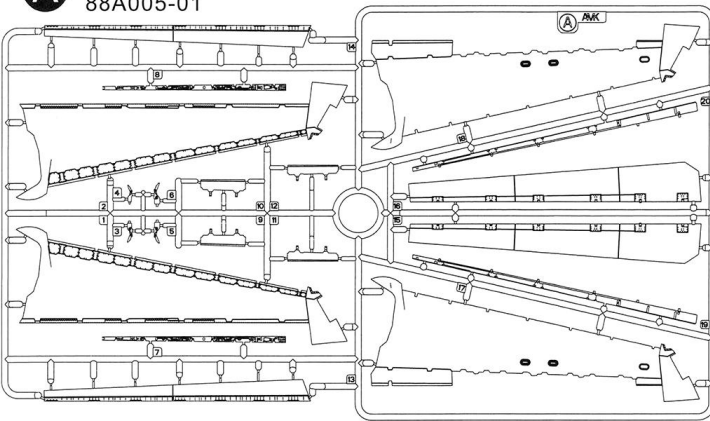

**B** PARTS X1  
88A005-02

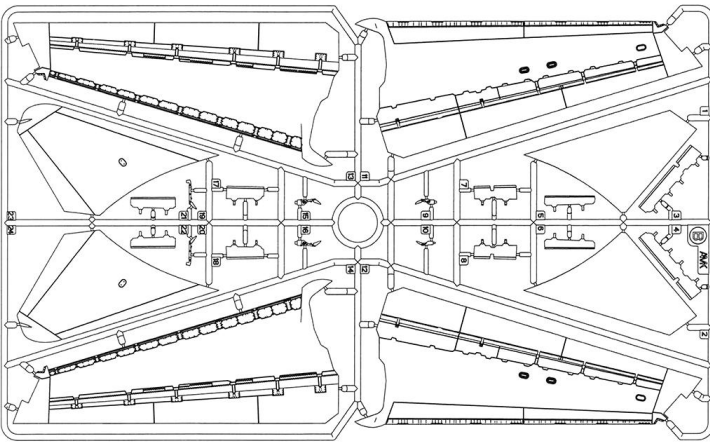

**G** PARTS X1  
88A005-07

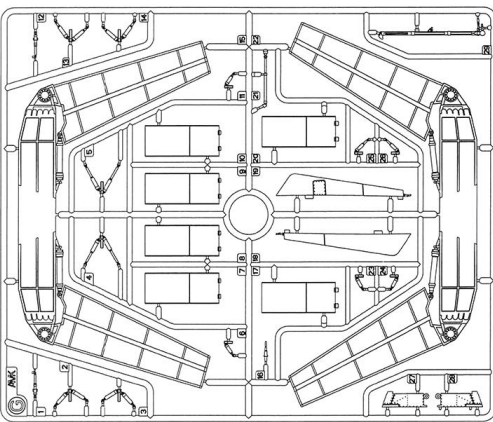

**J** PARTS X1  
88A005-10

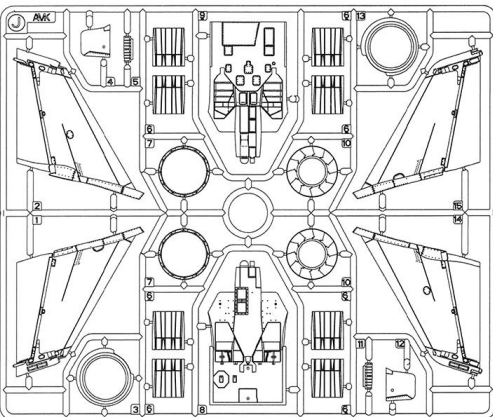

**C** PARTS X1  
88A005-03

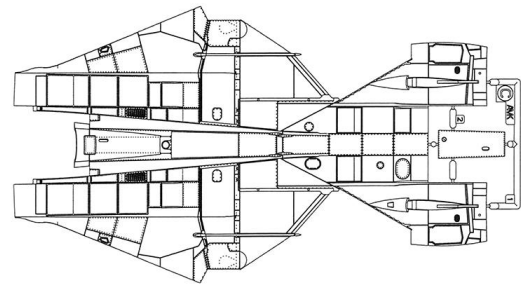

**D** PARTS X1  
88A005-04

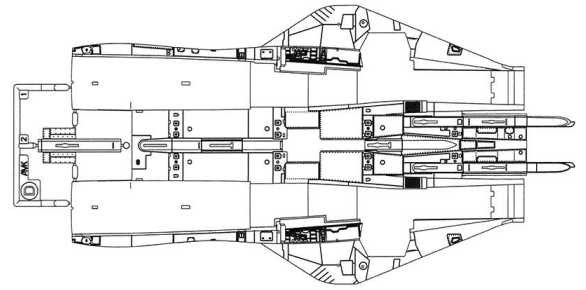

**E** PARTS X1  
88A005-05

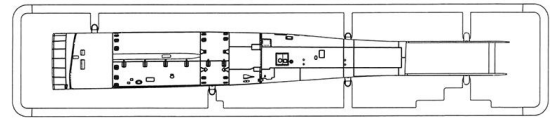

**F** PARTS X1  
88A005-06

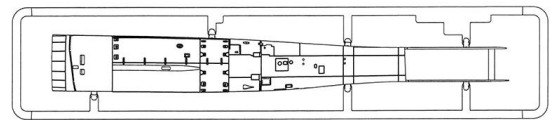

**H** PARTS X1  
88A005-08

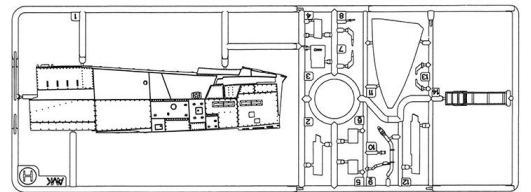

**K** PARTS X1  
88A005-11

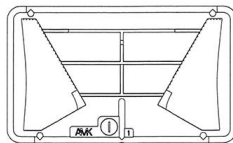

**I** PARTS X1  
88A005-09

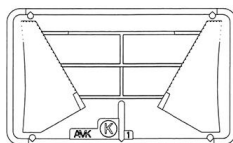

**L** PARTS X1  
88A005-12

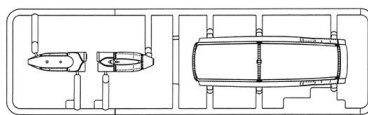

**M** PARTS X1  
88A005-13

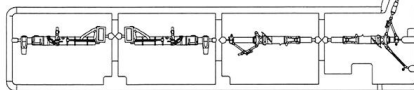

**N** PARTS X1  
88A005-14

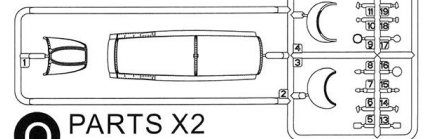

**O** PARTS X2  
88A005-15

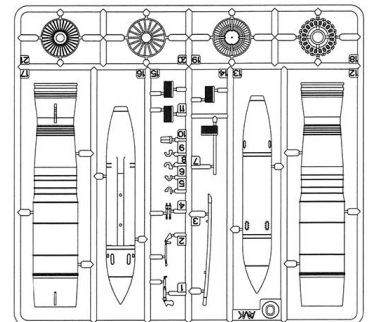

**P** PARTS X1  
88A005-16

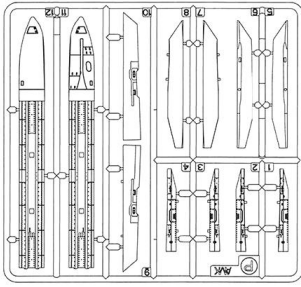

**R** PARTS X1  
88A005-18

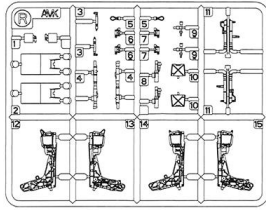

**U** PARTS X1  
88A005-21

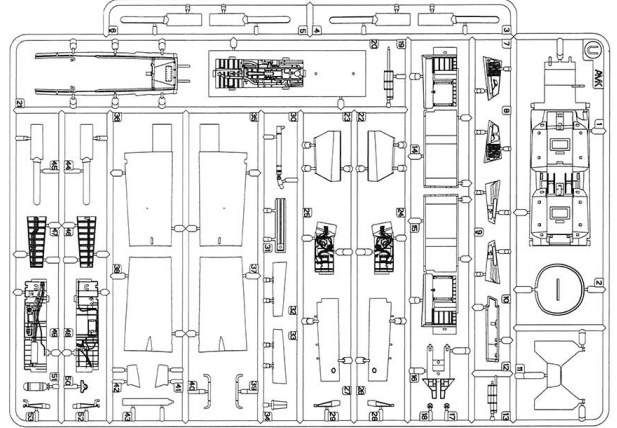

**Q** PARTS X2  
88A005-17

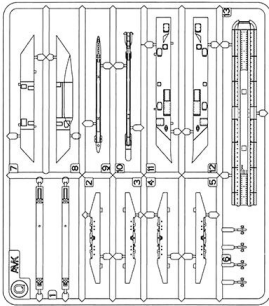

**S** PARTS X2  
88A005-19

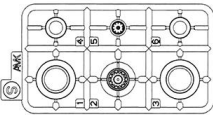

**T** PARTS X1  
88A005-20

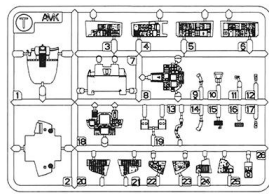

**V** PARTS X1  
88A005-22

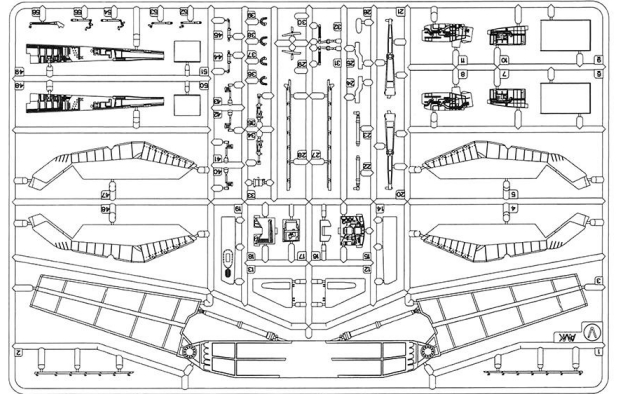

**ZA 08** PARTS X4  
99608

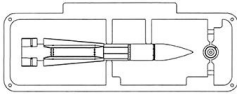

**ZA 07** PARTS X2  
99609

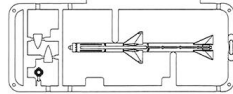

**ZA 10** PARTS X2  
99610

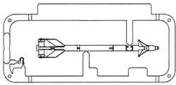

PARTS X1  
88A005-26

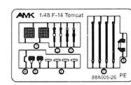

PARTS X1  
88A005-34

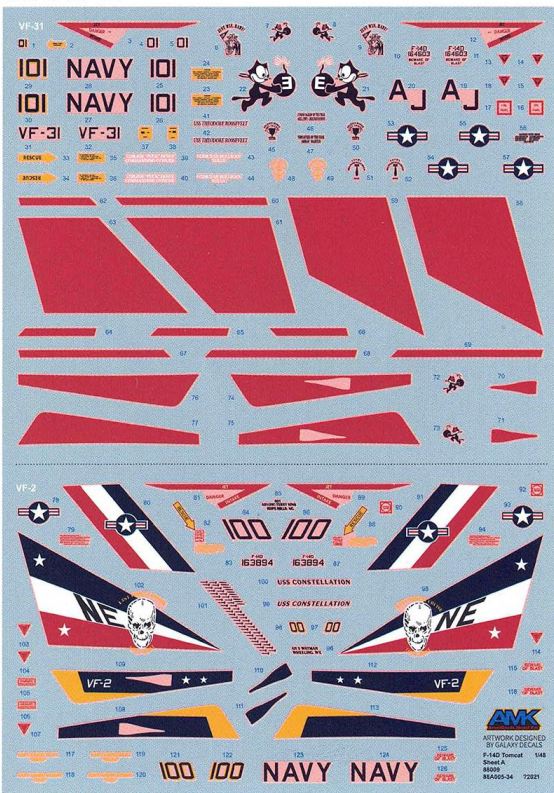

PARTS X1  
88A005-35

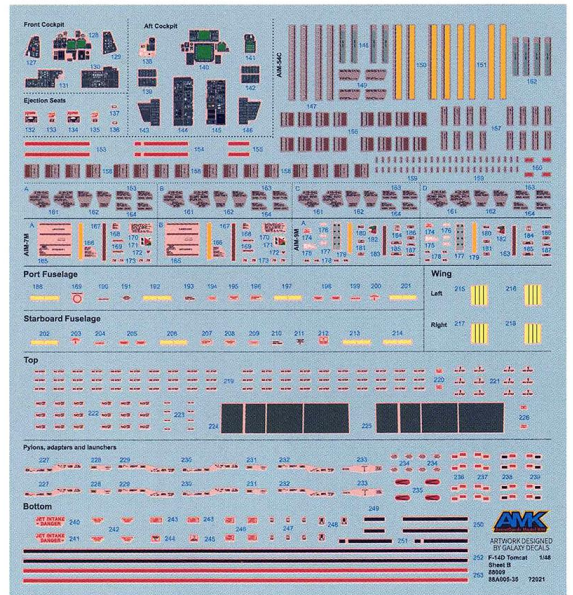

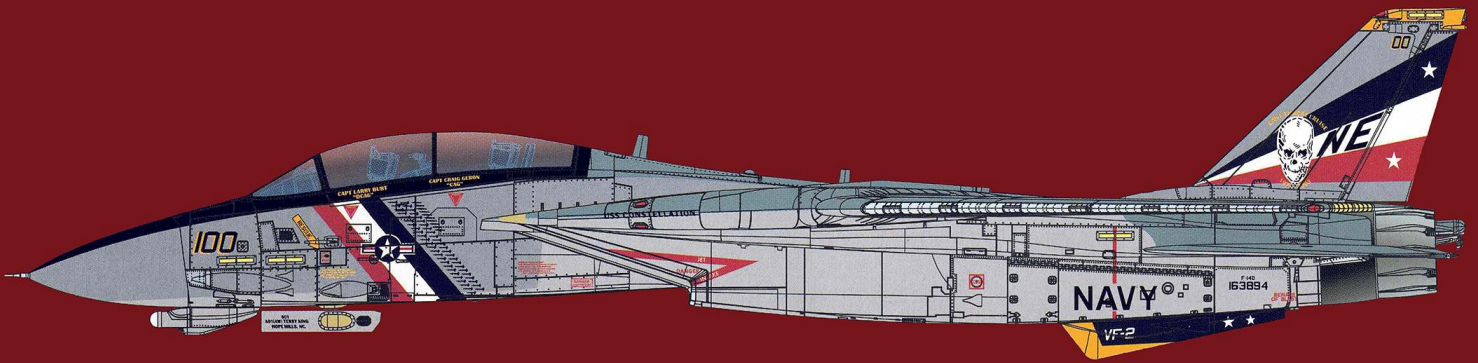

AvantgardeModelKits(AMK)Co.,Ltd.

[www.amkhobby.com](http://www.amkhobby.com)

 AvantgardeModelKits



MADE IN CHINA  
© Copyright 2021, AMK



F-14D  
Super Tomcat  
1/48 SCALE

