

Spitfire F/FR Mk XIVe Conversion

1/32 Conversion Set for Tamiya Spitfire MkXIVe "Low Back"

Laminar Flow Design
 Email : info@laminarflowdesign.com
www.laminarflowdesign.com



- Working with 3D printed parts.
 - Removal of the supports: Parts are printed into an enclosed cage that protects them in the different stages of production, transport and storage. Please cut the 4 pillars at their base on the corners and clean up the remaining mesh to access the parts. Then you can remove the parts from their support, starting by the most accessible on the sides and working your way to the center. Work support by support, using razor saw or new scalpel blade.
 Avoid snapping the part off its supports as it could damage the part in the process.
 - Outer fuselage surfaces (ie: Sides of the cowling) might need Surfacer and sanding work for optimal result. Please try to avoid filling small rivets in the operation.
 - Don't "force fit" parts into assembly. Cured resin is very hard, but will break under pressure.
 - For accurate fitting, prefer trimming and sanding the plastic parts rather than resin. Plastic is easier to form and shape. But ultimately the choice is up to the builder.
 - Washing agent residues can remain on some surfaces, fine grid sand to get rid of them
- Preparatory work
 - Fuselage:
 - Fuselage cuts: Please refer to the image for the tail post and engine cut out. There is no template provided for these cut as they are quite straightforward, and are along the panel lines. Use razor saw for the cut, and finish with scalpel and Flat file.

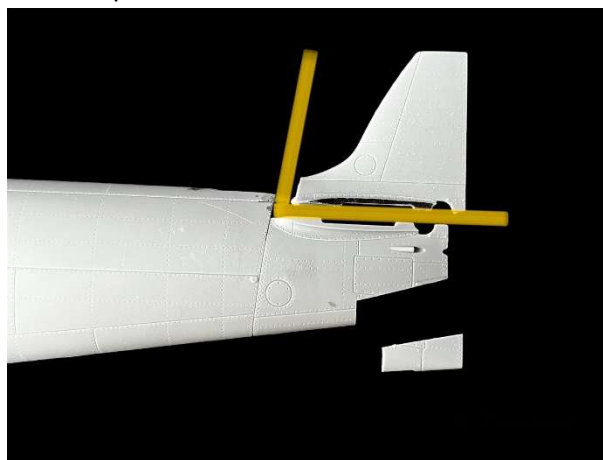
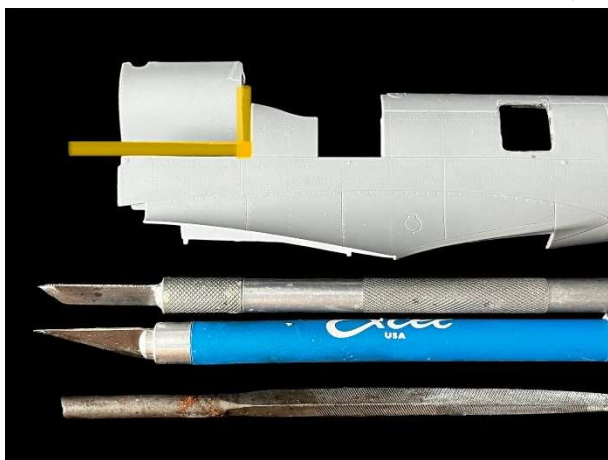

- Griffon Nose: place the windshield base template (located on Mask sheet D5) on a 0.5mm thick plastic sheet and cut a part out of it. Form it to the tank outer curve and CA glue it in the windshield recess on the resin nose. This is to ensure that the windshield part can be glued to the fuselage without CA glue and avoid fogging on the clear part.



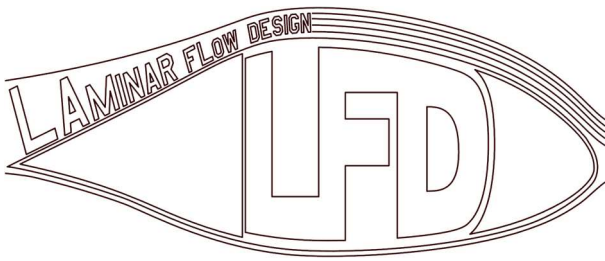

Spitfire F/FR Mk XIVE Conversion

1/32 Conversion Set for Tamiya Spitfire MkXVIe "Low Back"

Laminar Flow Design
 Email : info@laminarflowdesign.com
www.laminarflowdesign.com



- Hatches : Refer on the version you are building. Use the corresponding template to mark the position, once satisfied, attach temporarily the template with tape. Drill multiple holes and finish with scalpel to remove the inner portion. Finish with flat and round files to conform to the template opening. Check the fit of the hatch with your opening regularly, but again, don't force it into, it would break.
 - For FR Spitfire, all 3 hatches needs to be installed. Take extra care on the LH front Hatch, the template must be aligned with the sides of the existing hatch that sits higher on the fuselage. Once opened, fill and sand the remnants of the original hatch (Hinge and panel line)
 - For F spitfire, add the rear right fuselage only. The LH Side front Hatch on the Tamiya fuselage needs to be filled and smoothed, prolong existing rivets lines to blend in your work. (Note: some modern restorations feature a LH side access hatch with no camera opening. It is provided as an option)

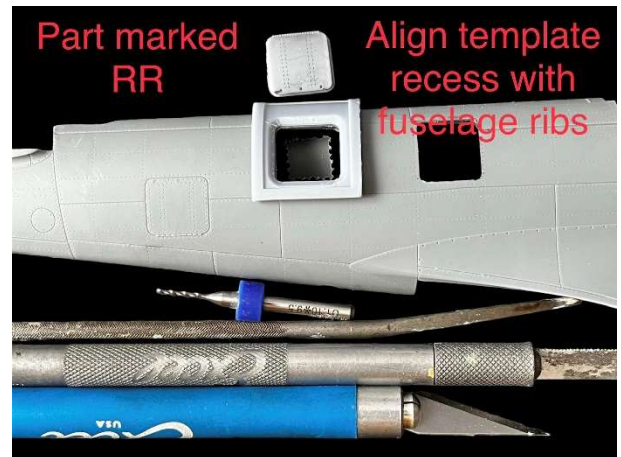

- Retractable Tail Wheel: Start with the LH side template, it slots into the rudder actuator recess on the fuselage. Fix it with tape, then fix the RH side template at the exact same height. Once happy, proceed with razor saw, scalpel and finish with flat file.

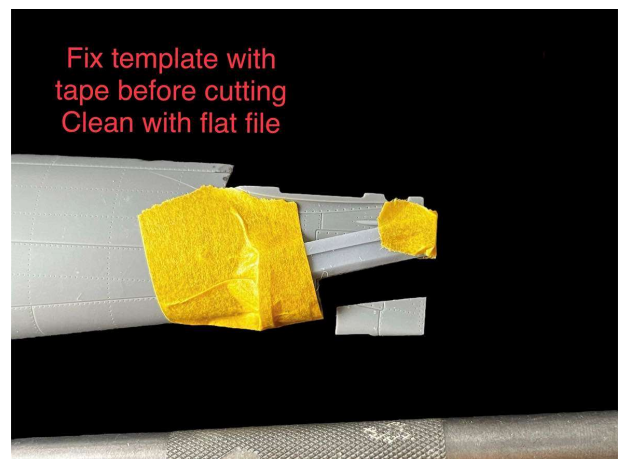

- Tail Post: With the original tail chopped off, all left is to remove material to allow for the strengthening rib on the tail post. Width of the rib is 1mm.

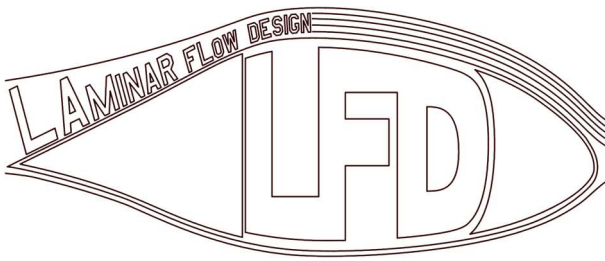

Spitfire F/FR Mk XIVe Conversion

1/32 Conversion Set for Tamiya Spitfire MkXIVe "Low Back"

Laminar Flow Design
 Email : info@laminarflowdesign.com
www.laminarflowdesign.com



- Fuselage ID light: (Optional, check your subject references). Mark a point at 16.5mm from the wing joint, right in the axis. Then drill a 5.1mm diameter hole from that point, use round file to bore at the right diameter.



○ Wings:

- Fuel Tanks: Use templates as shown in the pictures. Mark 1st with a fine pencil, once happy with the location, fix the first template and scribe the outline with your preferred engraving tool. Then fix the 2nd template inside the first, and proceed to engrave the filling port. Sand clean and fix with a small drop of extra thin.

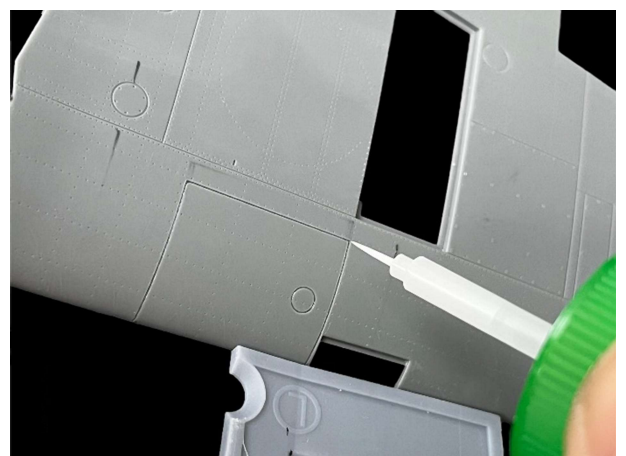
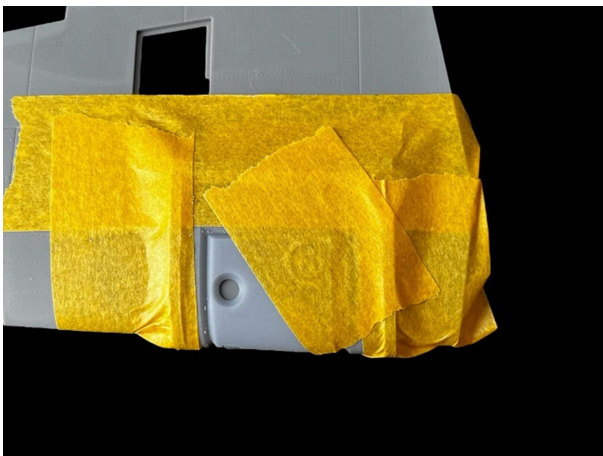
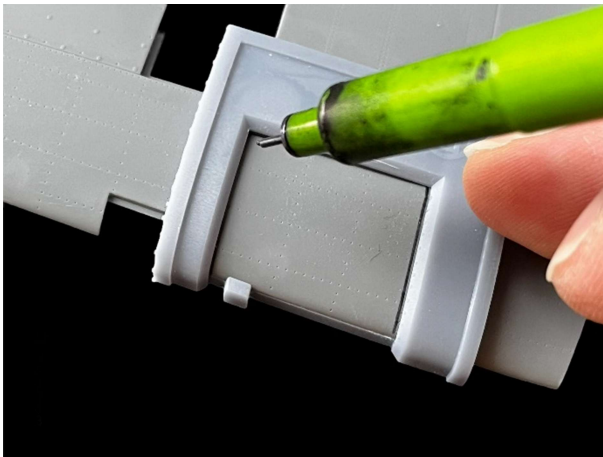

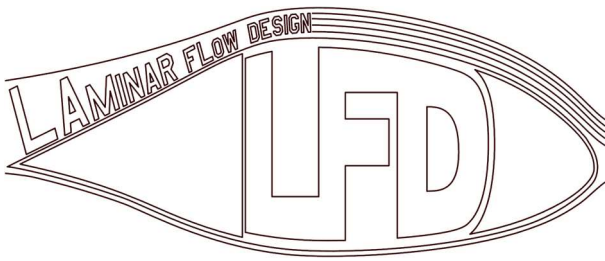

Spitfire F/FR Mk XIVE Conversion

1/32 Conversion Set for Tamiya Spitfire MkXVIe "Low Back"

Laminar Flow Design
 Email : info@laminarflowdesign.com
www.laminarflowdesign.com



Add rows of fasteners and rivets per the last picture (courtesy of MkVIII wing)

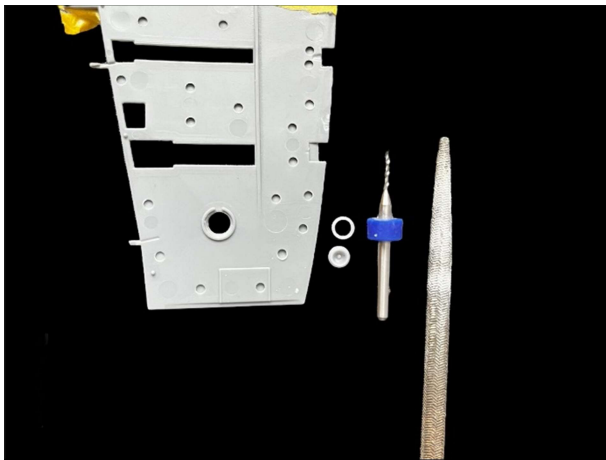
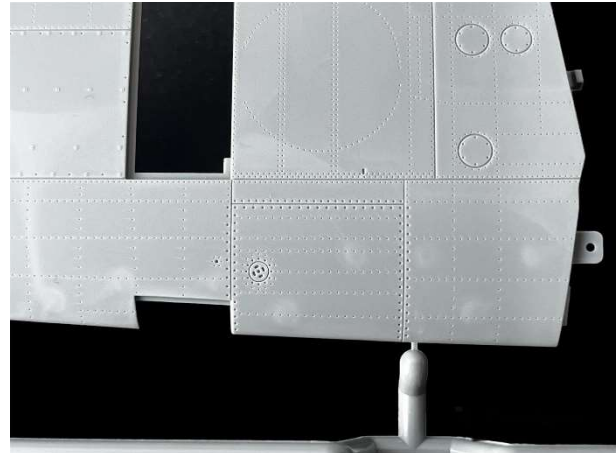

- Downward ID lights (Optional, check your subject references): Drill the pre-molded part inside the wing, finish the diameter with round file. Test fit with the assembly.

- Ailerons Shortening: Cut Parts B5/B6 at the outer line, keep cut parts to reassemble with the wings, eventually add a plastic strip along the seam to keep the alignment. putty and sand the joints to blend in the wing. See Reference pic.

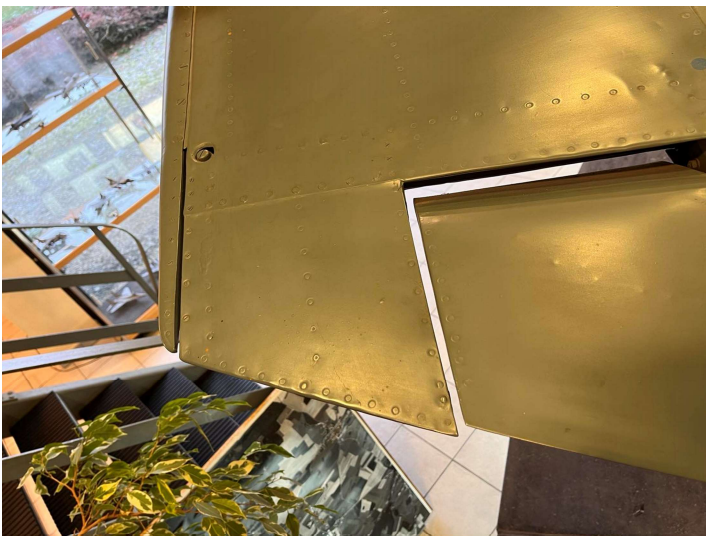

Congratulations, you have finished the preparatory work.

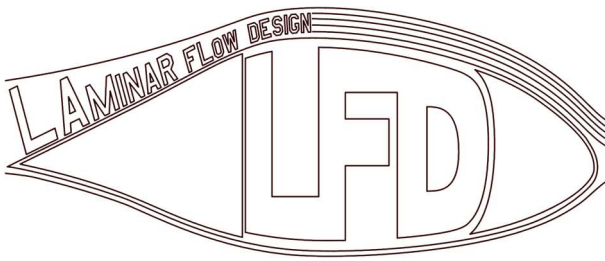

Spitfire F/FR Mk XIVE Conversion

1/32 Conversion Set for Tamiya Spitfire MkXVIe "Low Back"

Laminar Flow Design
 Email : info@laminarflowdesign.com
www.laminarflowdesign.com



- General Assembly:

- Fixation of the nose: Proceed on Step 15 on the model assembly, but omit part G6 when assembling fuselage (Check Tail post instructions when assembling the fuselage). Slide Part G6 (+G3+Polycaps) into the nose protruding pins, but don't glue it.
- Place the nose assembly into the assembled fuselage and place part G6 in its side locating holes. Test fit and CA glue part G6 to the resin nose (via the 2 slide pins). Hold in place and let dry.

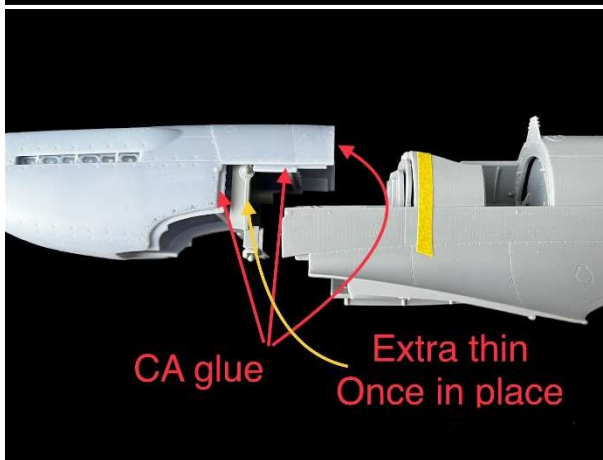

Take out the nose with affixed G6 part, apply CA glue on all contact surfaces and put the nose back in place. To Reinforce the bond, apply Extra Thin glue on the contact surface between G6 Part and fuselage.

Assembly of the nose parts: Use parts from cage 2 and 3.

Add the Spinner Counter plate at its base (Not on the below picture). Avoid Gluing the Propeller Axle, it is designed to allow turning the prop. Assemble part AA27 (provided in the box, but normally unused) to the rear of the carb intake.

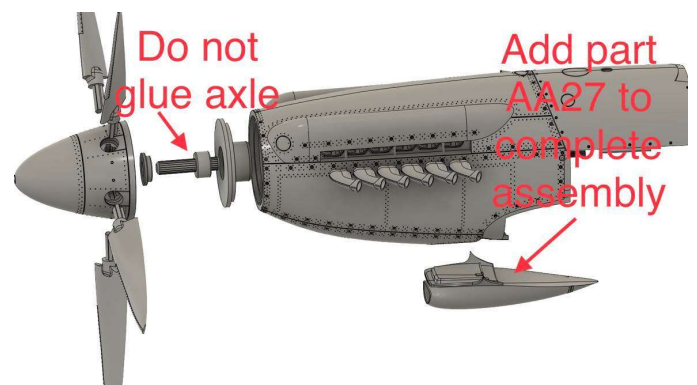
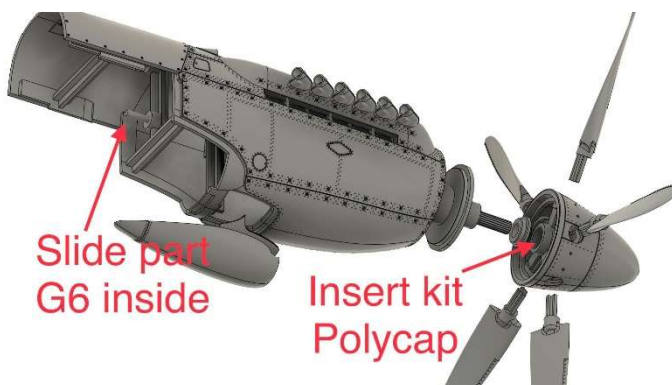

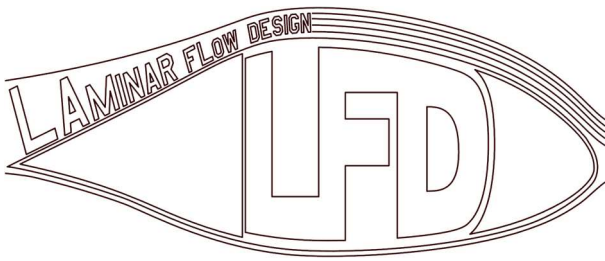

Spitfire F/FR Mk XIVe Conversion

1/32 Conversion Set for Tamiya Spitfire MkXVIe "Low Back"

Laminar Flow Design
 Email : info@laminarflowdesign.com
www.laminarflowdesign.com



○ Radiators

Clean contact parts and between the 2 grills to ensure optimal fitting. Absolutely don't force them into position, again, they would break. Position the vent open or closed at your discretion.

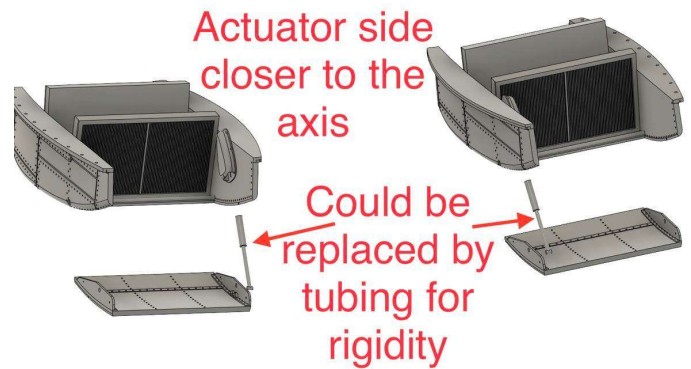

○ Tail Post

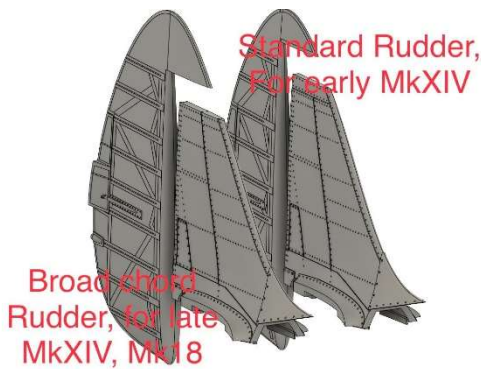

Choose between Std or enlarged rudder (check your references).

While special care has been taken to design the most fittable part as possible, the tail post assembly is a tad wider than the stock part, and thus require a few modeling skills:

The rear fuselage joint needs a bit of shimming to comply with the global width.

When assembling the fuselage, **do not** glue the fuselage part at the rudder junction (see picture).

Shim accordingly up and down to comply with the tail post and wheel well insert.

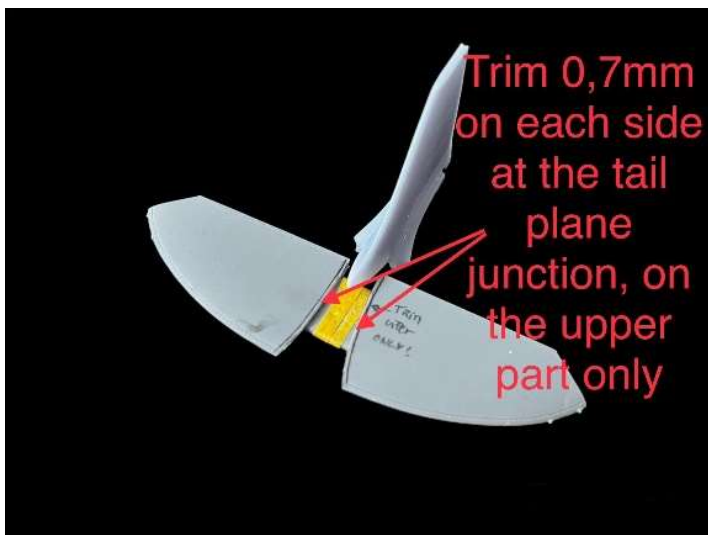
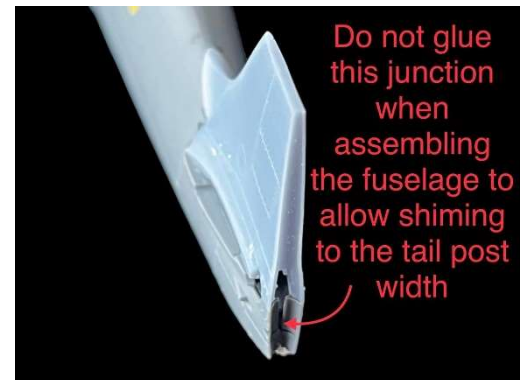

Last step, as the tail is a bit wider, there is 0.7mm to remove along the inner junction on the upper part of the horizontal tail plane. Keep the same contour. Best is to mark the line before committing to cut. See picture.

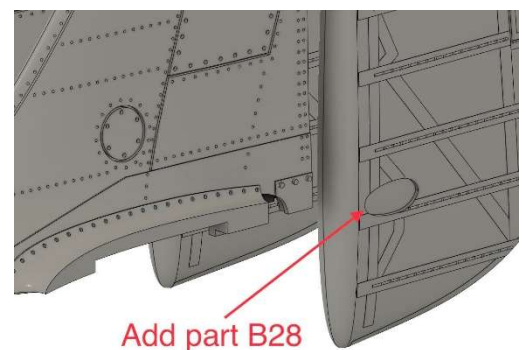

This step ensures there is a minimal gap on the underside of the tailplane.

Prepare the rudder and affix part B28 to it. But wait having shimmed the fuselage to the tail width, to fix the rudder

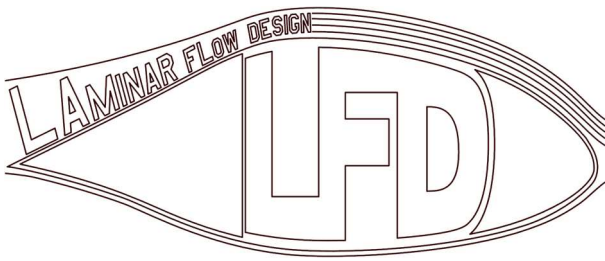

Spitfire F/FR Mk XIVE Conversion

1/32 Conversion Set for Tamiya Spitfire MkXVIe "Low Back"

Laminar Flow Design
Email : info@laminarflowdesign.com
www.laminarflowdesign.com



- Retractable Tail wheel

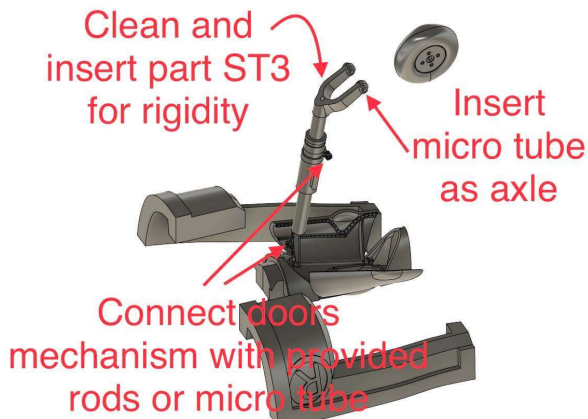

- Fuselage hatch (rear RH side): Use Part Marked RR located in plate 5 (the one inserted in the engine cage) Insert it upper side first, to clear the protruding hinge.

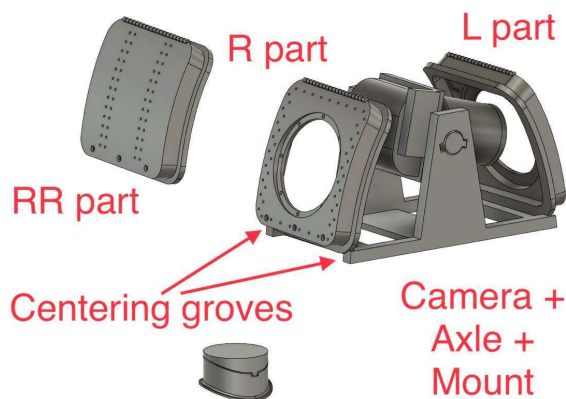

As per picture, insert the well into the fuselage. Slide the fork into its hole. Use a 0.5mm diameter Rod to complete the wheel assembly with the fork. Add the door mechanism rod (parts provided or micro tube)

Once assembled, take extra care to not break the doors as they are very fragile.

This assembly could wait the very end of your build.



- Fighter Recon Parts: Prepare 2 8mm diameter (+/-1mm Tol) round acetate sheets, and affix them to the camera ports from inside. Assemble the support, axle and camera (you can choose the camera looking side) Insert the camera hatches into the fuselage holes (the same way as previous step) Fix the camera assembly to the border of the hatches (self-centering grooves on the support)

- Downward ID light: Prepare 3 4mm diameter round acetate sheets and sandwich them into each light assembly. Slide the

lights into position in the wings and fuselage. Take care of the fuselage lamp orientation, check picture. For better accuracy, you can color the acetate sheet (amber center, ref left, green right).

Fuselage light (amber)



Wing lights (green & red)



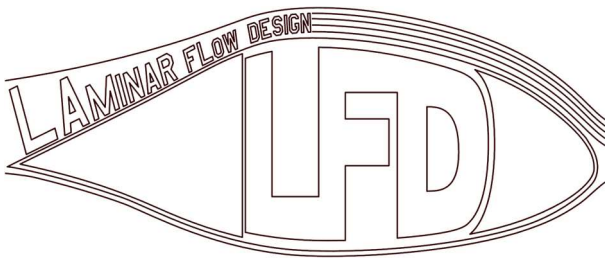

Spitfire F/FR Mk XIVe Conversion

1/32 Conversion Set for Tamiya Spitfire MkXIVe "Low Back"

Laminar Flow Design
 Email : info@laminarflowdesign.com
www.laminarflowdesign.com



- Painting and masks instructions:

- Arrow indicates the front direction, R/L the side of the plane.
- In order to avoid deformation during the mask application, apply a transfer tape over the masks during manipulation.
- Mask borders are to be aligned with panel line to help the positioning. Check on the drawing for the relevant panel lines.

Sheet A

Sheet B

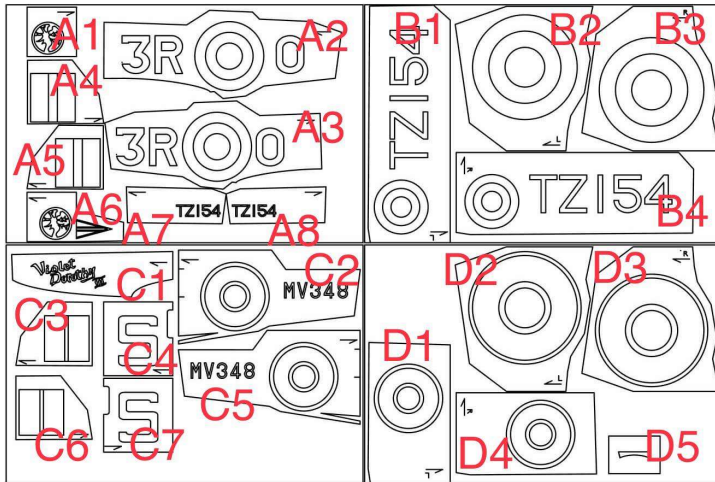

Sheet C

Sheet D

Scheme 1: Spitfire F XIVe SG-97/TZ154 "3R-O" 2nd Wing, 1st Squadron Belgian Air Force. 1949.

Use mask sheet A and B for this scheme.

Standard F Configuration, Mk18 Broad Chord Rudder.

Standard Grey Green RAF Paint Scheme.

Yellow (or white) dotted lines around the canopy

Sqdn Leader Pennant: light blue with dark blue outline and red bars

Thistle badge: White background, Red Outline, Green Thistle

Serial TZ154 (Black) obscured by the squadron letters (White)

Black Spinner

Belgian Flags: Black (Center/Front) Yellow Red (Outer/Rear)

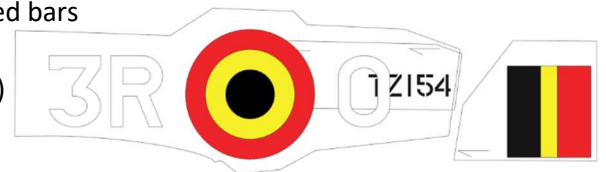
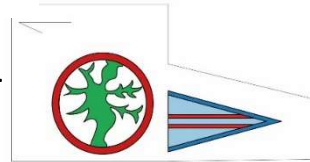

Scheme 2: Spitfire FR XIVe MV348 "S" 2TAF, 414th Squadron RCAF, 1945

Use mask sheet C and D for this scheme.

FR Configuration, Mk14 Standard Rudder, Downward ID lights installed, Fuselage Beam approach system (Part F58 in Tamiya boxing)

Standard Grey Green RAF Paint Scheme.

Cowl Art marking Yellow

"S" Marking : Sky

RAF Tail Flag: Red (Front) White Blue (Rear)

Black Spinner

Fuselage Rear band overpainted



**This wonderful scheme, and many others are covered in the excellent decal sheet from Aviaeology AOD32009m. we encourage you getting a sample of this decal set if working with masks seems a bit complicated. There is also many tips regarding the FR Spitfire equipments & Variants

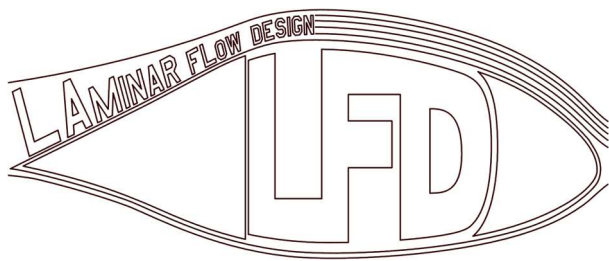

Spitfire F/FR Mk XIve Conversion

1/32 Conversion Set for Tamiya Spitfire MkXVIe "Low Back"

Laminar Flow Design
Email: info@laminarflowdesign.com
www.laminarflowdesign.com

