

# U. S. NAVY **Avenger** TBF

## TORPEDO BOMBER



PLASTIKIT PA31

MONOGRAM MODELS, INC.  
Chicago 32

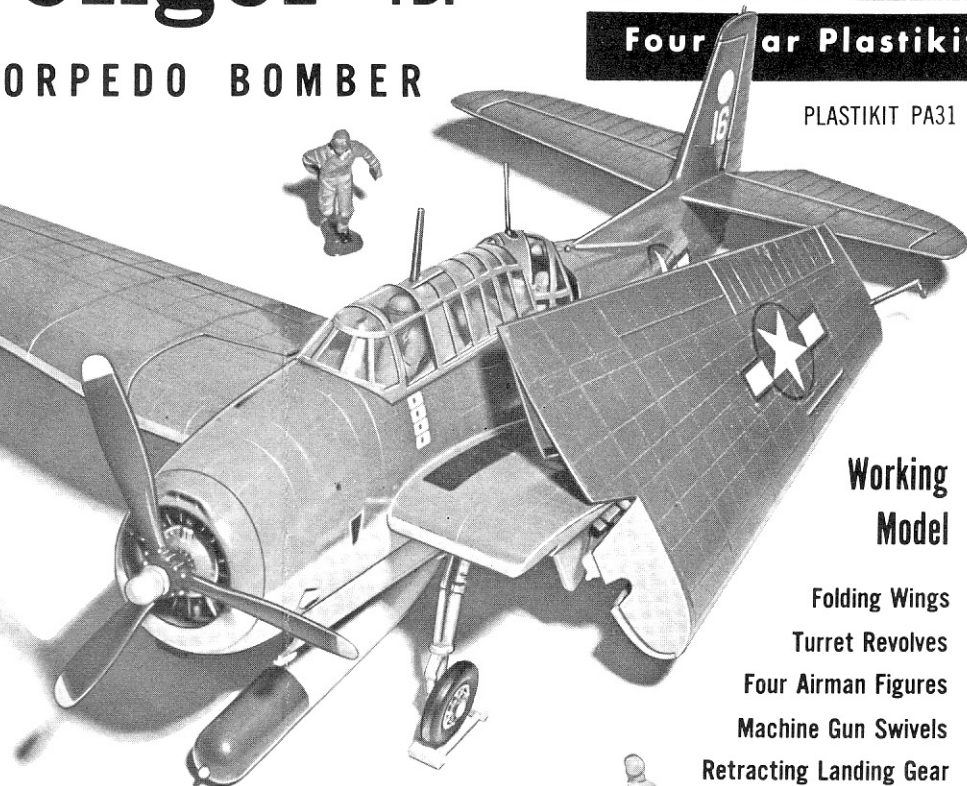

**Working Model**

- Folding Wings
- Turret Revolves
- Four Airman Figures
- Machine Gun Swivels
- Retracting Landing Gear
- Bay Doors Open and Drop Torpedo



## Deadly Torpedo Bomber of World War II

The U.S. Navy's TBF Avenger earned the reputation as the most deadly torpedo bomber ever developed, in the battles in the Pacific during World War II. Developed and built by Grumman Aircraft Engineering Corp., it became the standard torpedo bomber of the Navy and was produced in larger numbers than any other torpedo bomber ever used. Many Avengers were built by General Motors Corp. and designated TBM.

The Avenger is a big plane with a wingspan of 54 feet, 2 inches. It is powered by a Wright double-row R-2600 Cyclone engine developing a maximum of 1600 horsepower and has a top speed close to 300 mph. It is designed to carry a standard torpedo or 2000 lbs. of bombs, and is the first torpedo bomber to carry the torpedo entirely within the fuselage. Armament includes a .50 caliber machine gun in the front cowl, another .50 in the power operated ball turret.

The TBF normally carries a crew of 3 men, pilot, gunner and radioman, who also manned the lower guns in some models.

### About Your Model

Your Monogram model of the Avenger is a faithful miniature of the big plane, developed from plans, specifications and photographs supplied by the U.S. Navy and Grumman Aircraft Co. It has been molded in the correct shade of blue plastic to eliminate the need for lots of painting.

Note the operating features of your model: the wings fold just like those on the big plane for carrier storage; the ball turret turns and the machine gun elevates; the landing gear, tail wheel and arresting hook are retractable; the entrance hatch in the fuselage opens; the torpedo bay doors open to drop the scale torpedo. Note also the beautifully sculptured figures of the pilot, radioman, gunner and flight deck officer. It's a model to provide lots of fun assembling and one you can be proud to show to your friends.

**CAUTION: The wing folding mechanism is very delicate—handle carefully! If desired, wings may be cemented in open or closed position.**

### Finishing Color Suggestions

**BLUE**—Upper portion of fuselage, wings and stabilizer. Do not paint. Framework on clear canopy and ball turret. Match color of paint to color of blue plastic.

**AIRCRAFT GRAY**—Bottom of wing and stabilizer, lower portion of fuselage, and framework on rear window.

**LIGHT GREEN**—Interior of fuselage in cockpit area, floorboard, seats, interior of wing areas visible when wings are folded, interior of wing doors, crew door, strut covers, and tailwheel door.

**BLACK**—Tires, propeller blades, engine cylinders, turret mechanism, machine gun and arrestor hook.

**YELLOW**—Tips of propeller blades.

**SILVER**—Landing struts, tailwheel, propeller spinner, ignition ring and pushrods on engine, and rims and spokes on wheels.

**PILOT, RADIOMAN AND GUNNER**—Tan suits, flesh faces and hands, brown helmets, silver goggles with tan straps, yellow life jackets, light olive drab parachute and straps, black shoes and brown clipboard in hand of radioman.

**LANDING SIGNAL OFFICER**—Flesh face and hands, yellow helmet and jacket, yellow signal paddles with red stripes, silver goggles with tan strap, tan pants and brown shoes.

**TORPEDO**—White body and fins and red nose section.

# STUDY THIS EXPLODED DRAWING

Become familiar with the name of every part, where it goes and how it fits with other parts before you begin assembly.

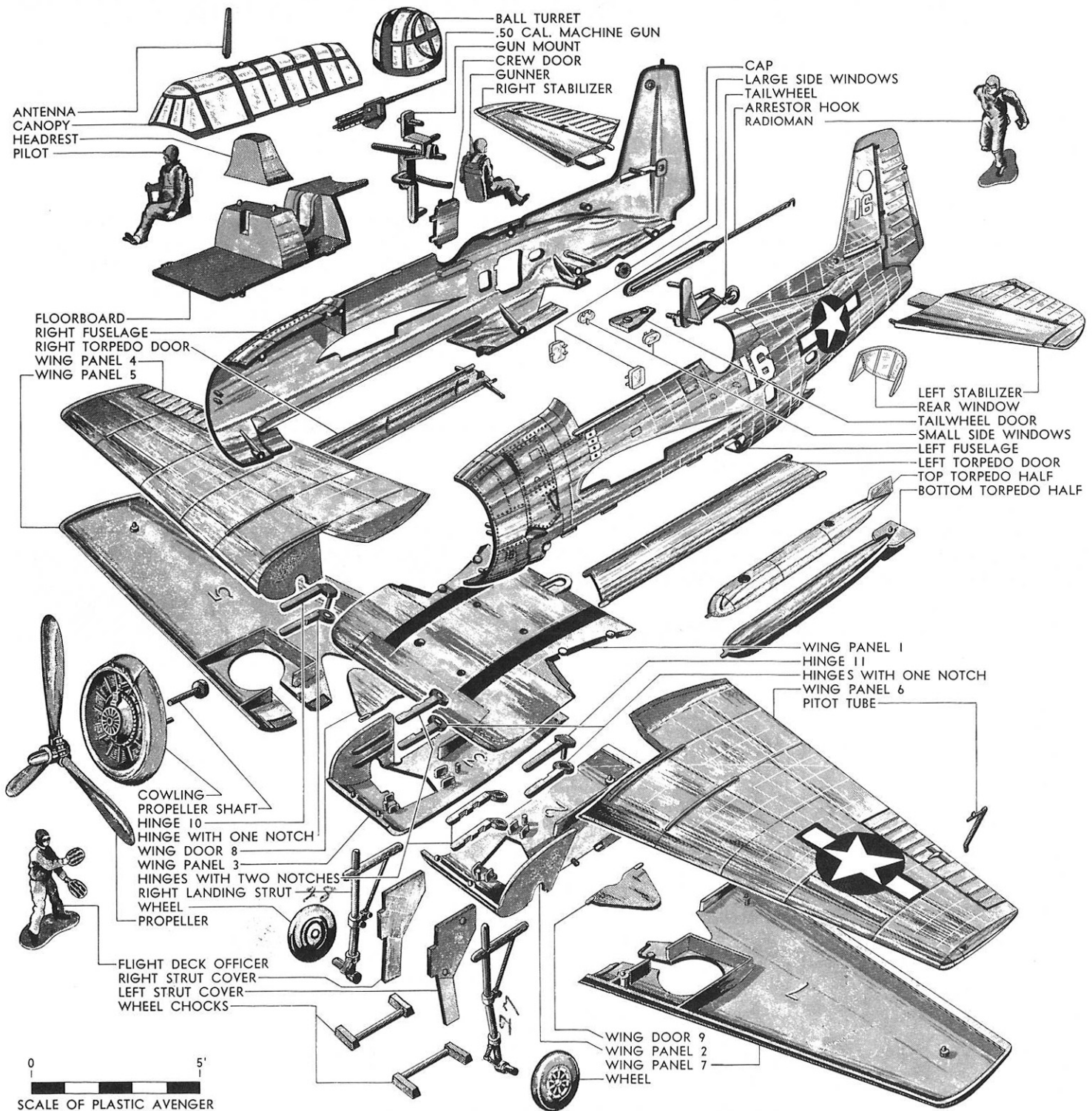

## Read This Before You Begin Assembly

Study the exploded drawing on this page and the assembly sketches to become familiar with all of the parts of the model and how they fit together. Then follow carefully the procedure shown and you will be rewarded with a beautiful scale model.

Before starting assembly, remove all plastic parts from the "trees" to which they are attached and carefully trim away any excess bits of plastic with a sharp knife. Place the parts required for each assembly sketch in front of you. Then check the fit of each part before you cement it in place.

Use plastic cement to join the parts. We recommend the use of **Monogram Plastikit Cement**, an excellent material for bonding all polystyrene plastics. Make a hole in the nozzle of the cement tube with a straight pin. After applying cement to a part, replace the straight pin immediately to prevent the cement from drying out. Use rubber bands where necessary to hold parts firmly together and allow cement to dry thoroughly before handling the parts. If you are going to paint the details on your model, refer to the "Color Finishing Suggestions" on page one, and to the paragraph "Painting Your Model" on page three.

## HOW TO APPLY DECALS

Cut the decal apart with scissors inside the dotted line. For a neat job, trim right close to color outline with scissors. Work with one subject at a time. Dip it in water for a few moments until it slides easily on the paper backing. Study drawings for correct location. Slide the decal partly off of the paper backing, holding decal in correct place on model while sliding backing out from underneath. The decal can be shifted on the model into the correct position after lifting it and applying a little water around the edges with your finger. Press out bubbles and blot with a soft rag.

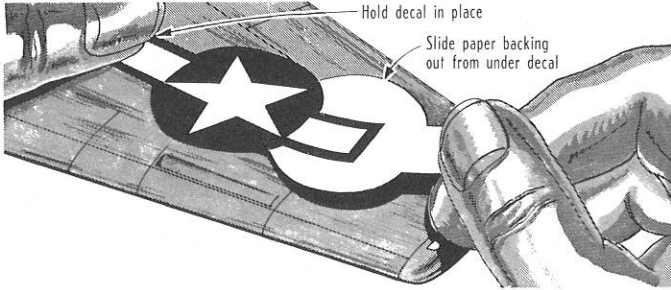

## PAINTING YOUR MODEL

If you are going to paint your model, read the assembly instructions before you begin assembly and plan your work because it is easier to paint some parts **before** they are attached to the model and before decals are applied. Follow the suggested colors on the front page. Only **enamel** or **paint for plastics** should be used. Use a small pointed brush for details. Do **not** paint surfaces that will be cemented because cement will not hold well to a painted surface. Allow time for paint to dry thoroughly before handling parts. Clean and wipe brushes thoroughly before using another color.

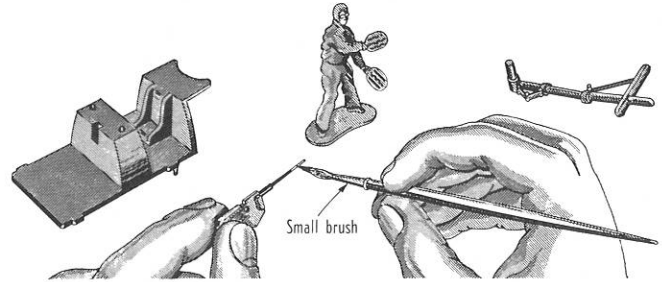

## AVENGER ASSEMBLY DIRECTIONS

**CAUTION: WHEN USING CEMENT, USE SPARINGLY. TOO MUCH WILL CAUSE PLASTIC TO SOFTEN**

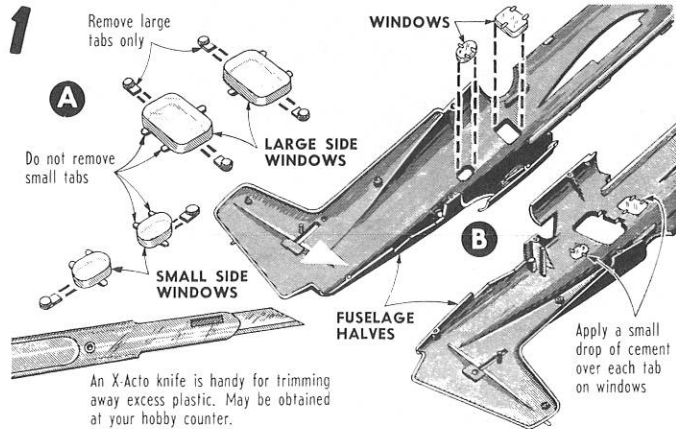

(A) Remove the large and small side windows from tree and break off large tabs. **Do not remove small tabs.** Carefully trim off excess material with a sharp knife at places where large tabs were attached. (B) Insert windows into openings in both fuselage halves as shown. Cement windows to fuselage by putting a small drop of cement over each tab.

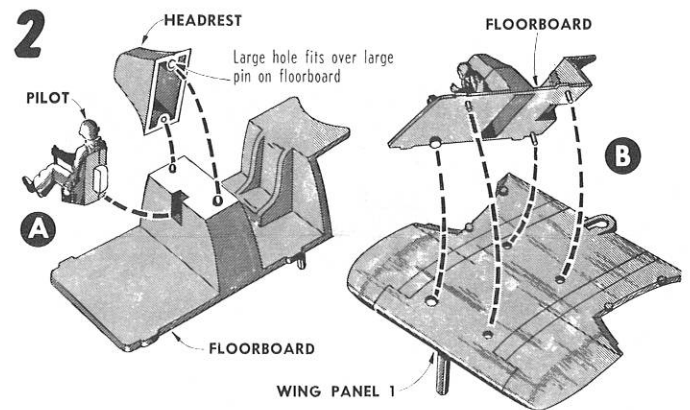

(A) Apply cement to two holes in headrest and attach it to top of floorboard. Cement pilot into slot at front of floorboard. (B) Apply cement into four holes in wing panel 1 and attach floorboard. Large pin on bottom of floorboard fits into large hole in wing panel 1.

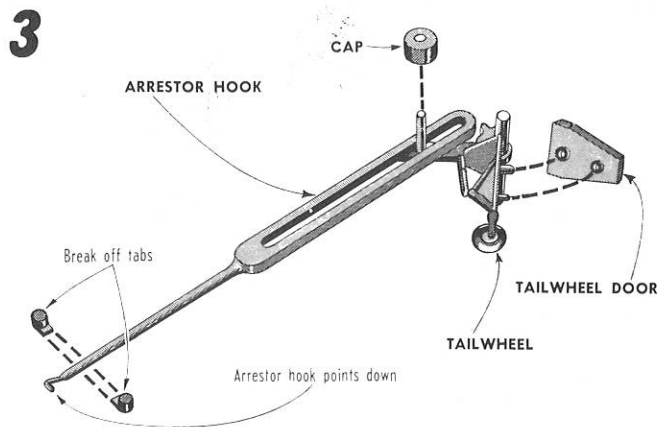

Break tabs off arrestor hook and trim away excess material with a sharp knife. Slip arrestor over pin on tailwheel making sure arrestor hook points down as shown above. Slip cap over pin on tailwheel and then apply cement. Cap must not be pressed against arrestor too tightly. Arrestor must slide on pin. Cement tailwheel door to two short pins on tailwheel.

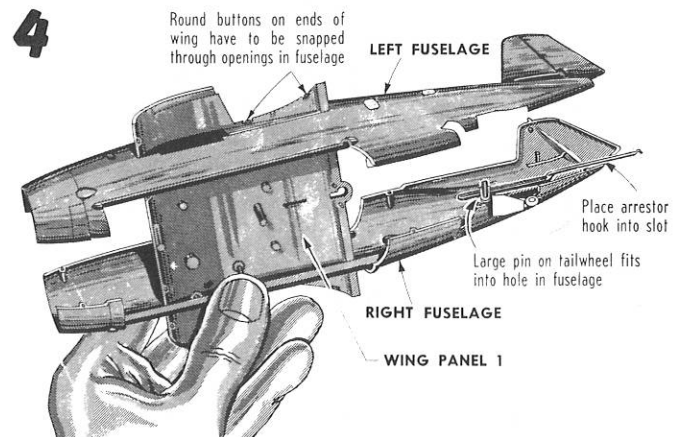

Slip both fuselage halves over ends of wing panel 1. **Do not cement.** Round buttons on ends of wing have to be snapped through openings in fuselage halves. Separate fuselage halves as shown by sliding them to ends of wing. Insert (do not cement) large pin on tailwheel into hole at rear of right fuselage and place arrestor hook into slot at rear. Then—



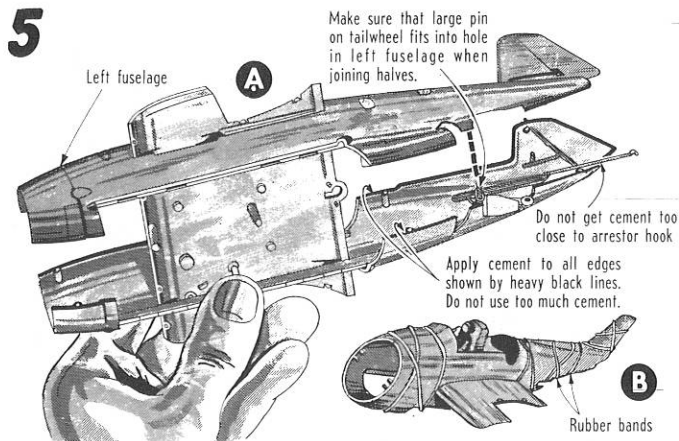

(A)—apply cement to all edges of right fuselage shown by heavy black lines above. Do not get cement too close to arrestor hook. Join fuselage halves, making sure that large pin on tailwheel fits into hole at rear of fuselage and that arrestor hook is in slot at rear. Push tailwheel and arrestor hook into fuselage. (B) Bind the fuselage with rubber bands for a tight cement joint.

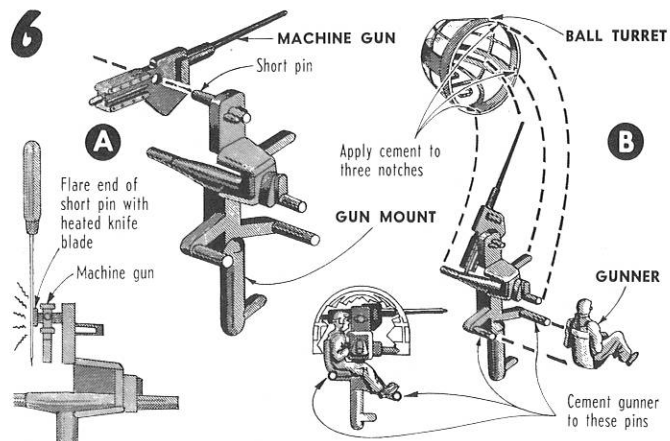

(A) Slip machine gun over short pin on gun mount with barrel pointing in direction shown. Flare end of short pin with heated blade of an old knife to hold machine gun on pin. (B) Cement gunner to two pins shown above. Apply cement to notches in ball turret and fit it onto three pins shown. Barrel of machine gun fits through slot in ball turret. Set turret aside to dry.

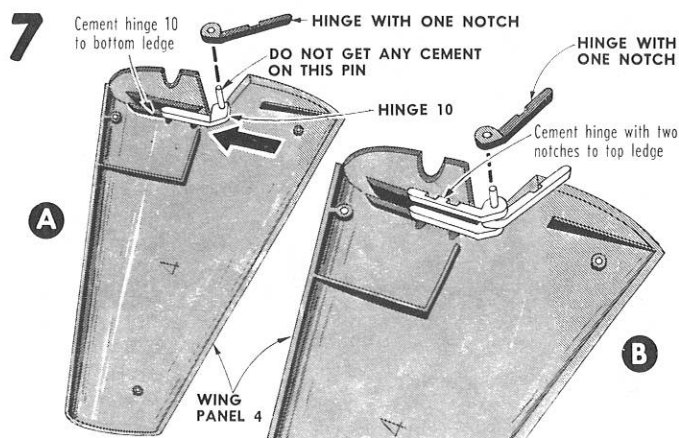

(A) Cement hinge number 10 to bottom ledge on wing panel 4 exactly as shown. Push hinge in direction indicated by large arrow as far as it will go. Slip a hinge with **one notch** over pin. **Do not cement.** (B) Slip a hinge with **two notches** over long pin and cement it to top ledge on wing. Finally slip a hinge with **one notch** over pin. **Do not cement.**

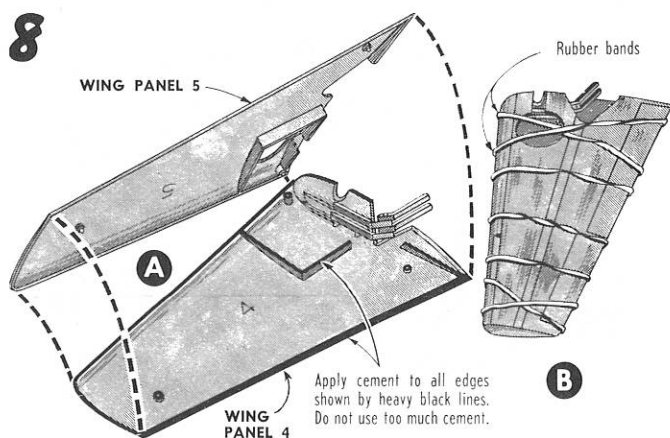

(A) Apply cement to edges of wing panel 4 as shown by heavy black lines and attach wing panel 5. (B) Bind wings tightly together with rubber bands for a tight cement joint. **CAUTION!** In the following steps where wings are attached to hinges, make certain hinges and wing panels are well cemented. **DO NOT ATTEMPT TO FOLD WINGS UNTIL CEMENT HAS DRIED AT LEAST 3 HOURS.**

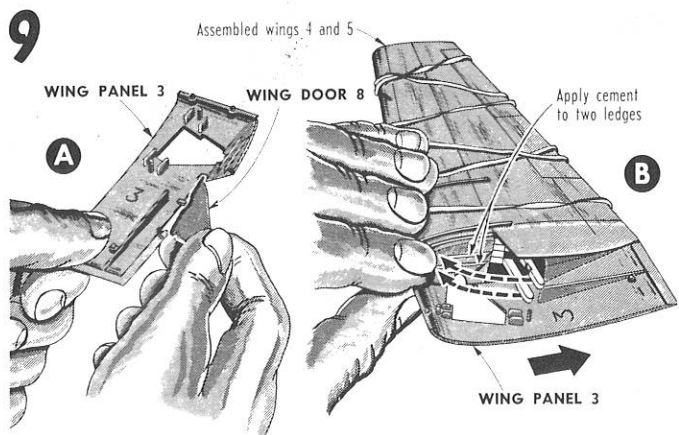

(A) Hold door 8 in vertical or opened position and insert front pin into front hinge in wing panel 3. Then snap rear pin into place. **Do not cement.** (B) Hold wing panel 3 against end of assembled wings 4 and 5 as shown. **Do not cement.** Apply cement to two ledges on wing panel 3 and press hinges into place on ledges. Push panel 3 in direction of large arrow as far as it will go and hold the hinges in place until cement sets.

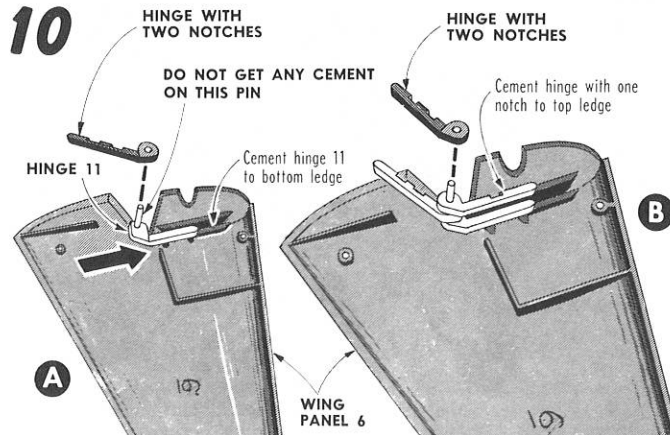

(A) Cement hinge number 11 to bottom ledge on wing panel 6 exactly as shown. Push hinge in direction of large arrow as far as it will go. Slip a hinge with **two notches** over pin. **Do not cement.** (B) Slip a hinge with **one notch** over long pin and cement it to top ledge on wing. Finally slip a hinge with **two notches** over pin. **Do not cement.**

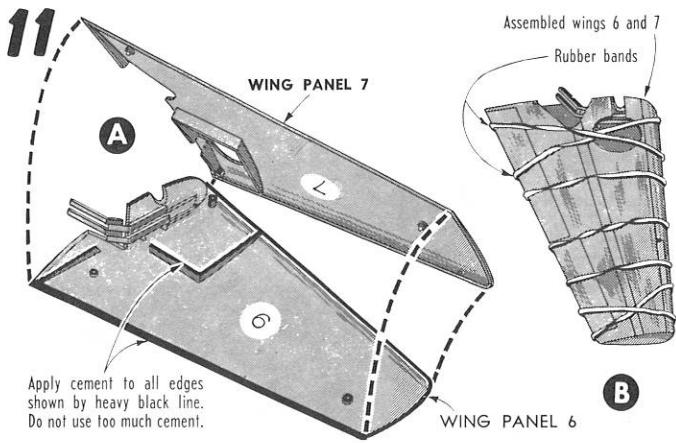

Apply cement to all edges shown by heavy black line. Do not use too much cement.

(A) Apply cement to edges of wing panel 6 as shown by heavy black lines and attach wing panel 7. (B) Bind wings tightly together with rubber bands for a tight cement joint. **ALLOW CEMENT TO DRY VERY THOROUGHLY BEFORE ATTEMPTING TO FOLD WING AT THE HINGE.**

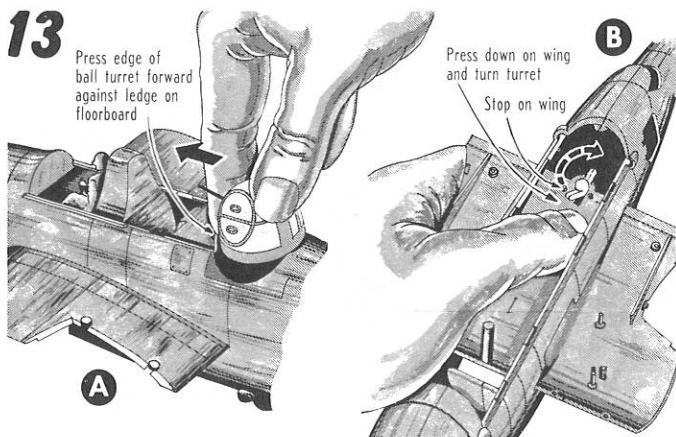

Install ball turret into fuselage as follows: (A) Place edge of ball turret against top ledge on floorboard with machine gun pointing forward as shown. Press turret forward against ledge so that it will spring and allow turret to fit into fuselage. (B) Turn fuselage over and fit tab on turret into slot in wing. Press down on wing and turn turret so that tab goes over stop on wing. **Do not cement.**

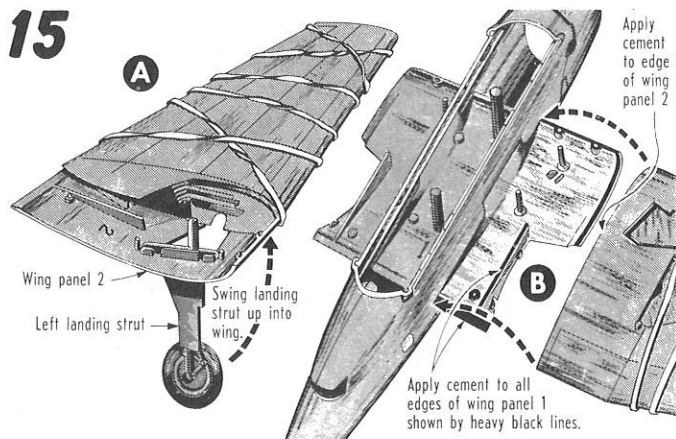

(A) Insert left landing strut into place on wing panel 2 and swing it up into wing. Slide a rubber band over the landing strut to keep it inside the wing. (B) Apply cement to edges of wing panel 1 as shown by heavy black lines and to edge of wing panel 2 and join the wings. Hold in place until cement sets. Insert right landing strut into place on wing panel 3 and attach other wing in the same manner.

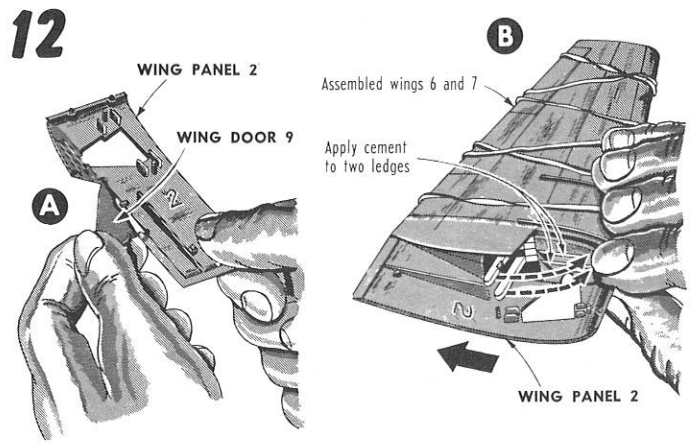

(A) Insert front pin on door 9 into front hinge in wing panel 2 and then snap rear pin into place. **Do not cement.** (B) Hold wing panel 2 against end of assembled wings 6 and 7 as shown. **Do not cement.** Apply cement to two ledges on wing panel 2 and press hinges into place on ledges. Push panel 2 in direction of large arrow as far as it will go and hold the hinges in place until cement sets.

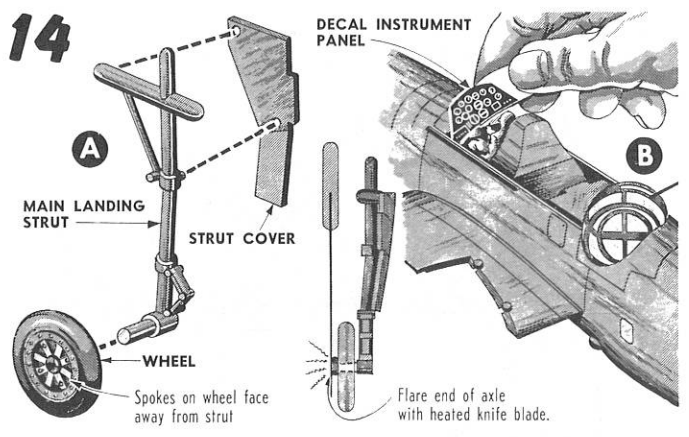

(A) Slip wheels onto axles of two main landing struts with spokes on wheels facing away from struts. Flare ends of axles with the heated blade of an old knife to hold wheels on axles. Cement strut covers onto pins on struts. (B) Cut out decal instrument panel close to black edge and apply it to front of cockpit.

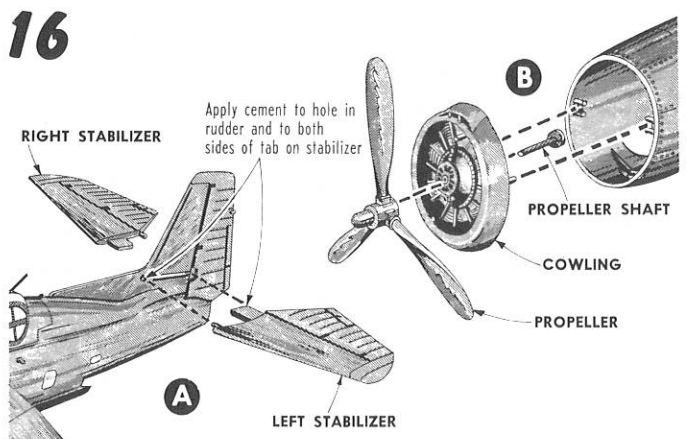

(A) Apply cement to small round hole in rudder and to both sides of tab on stabilizer and attach stabilizer to fuselage. Cement right stabilizer to fuselage in the same manner. (B) Insert propeller shaft through back of cowling. Apply cement to end of shaft and attach propeller. Cement cowling to front of fuselage.

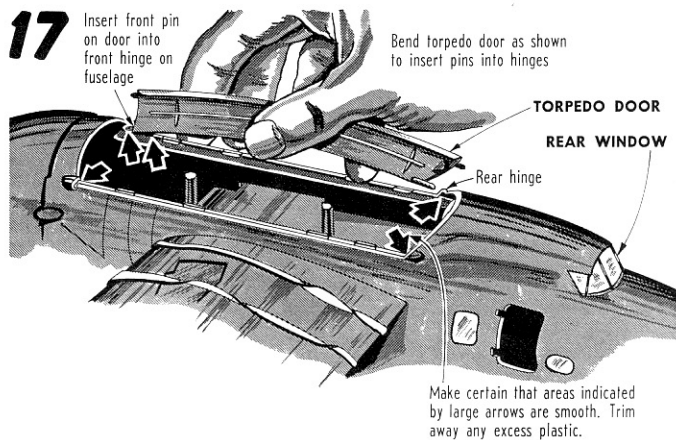

For best performance, torpedo doors must operate without binding. Any excess plastic on edges of doors or on door hinges in fuselage should be trimmed away carefully. To insert door, bend it as shown and insert front pin into front hinge on fuselage. Then insert rear pin into place. **Do not cement.** Install other door in the same manner. Apply cement to edges of rear window opening in fuselage and press rear window into place.

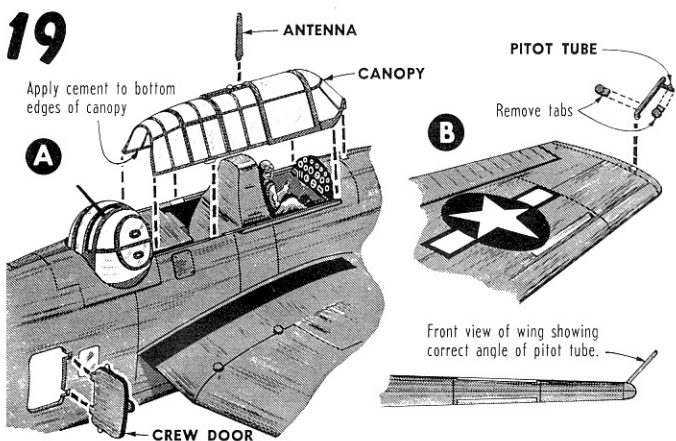

(A) Cement antenna into hole in top of canopy. Apply cement sparingly to bottom edges of canopy and attach it to fuselage. Cement crew door in either closed or open position. (B) Remove tabs from pitot tube and trim away excess material. Apply a drop of cement into hole in left wing tip and insert pitot tube. Note correct angle of pitot tube when viewed from the front.

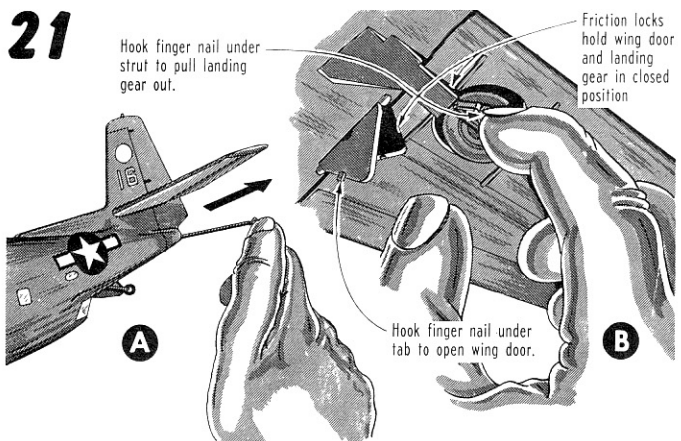

(A) To extend tailwheel, pull arrestor hook out as far as it will go and then push it back into fuselage. To retract tailwheel, push it up into fuselage. (B) Landing gear and wing doors are held in closed position with friction locks. To extend landing gear, hook finger nail under strut and pull gear out and down until it locks into the full open position. Open the wing door by means of the small tab.

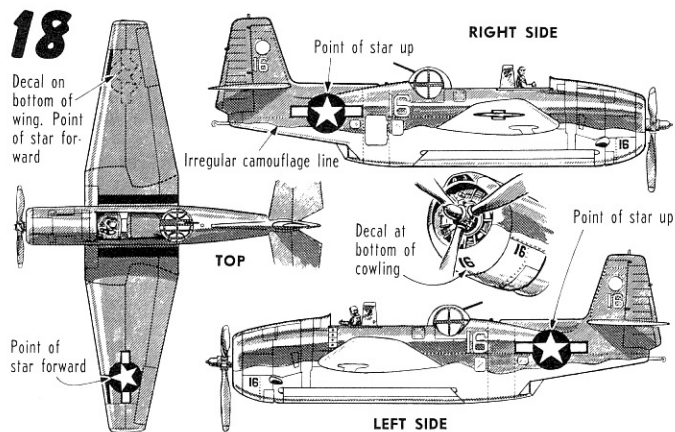

If you intend to camouflage paint your model it should be painted now. After paint has dried attach all the decal insignia in locations shown above. Notice that point on each star should face in direction indicated above. Refer to the paragraph "How to Apply Decals" on page three and follow these instructions closely for best results.

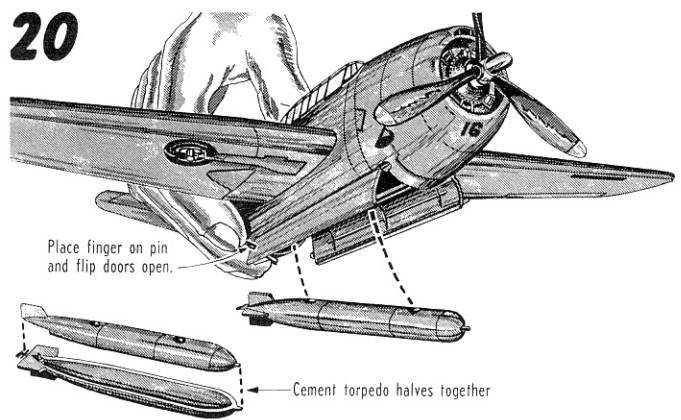

Cement torpedo halves together. To load torpedo, open doors and place torpedo onto two large pins inside fuselage. Close right door first, then the left. Friction locks on doors will keep them closed. To release torpedo, hold model in right hand in a flying attitude with finger on long pin at rear of right door and flip doors open with an upward and outward movement. If friction locks fit too tightly, add a bit of oil or vaseline.

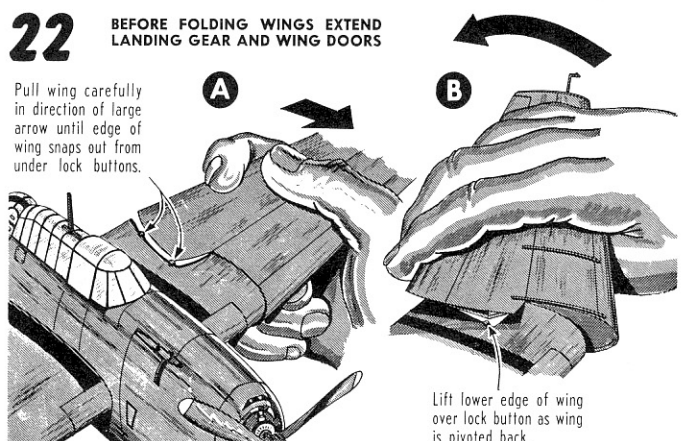

**IMPORTANT!** Before folding wings, first extend the landing gear and wing doors. (A) Grasp wing as shown and pull forward carefully until edge of wing snaps out from under round lock buttons. (B) Lift lower edge of wing (shown above) over lock buttons as wing is pivoted back. When folded, wing tips bind against stabilizer to hold wings in place. To extend wings, reverse the above procedure.



