

VIII.

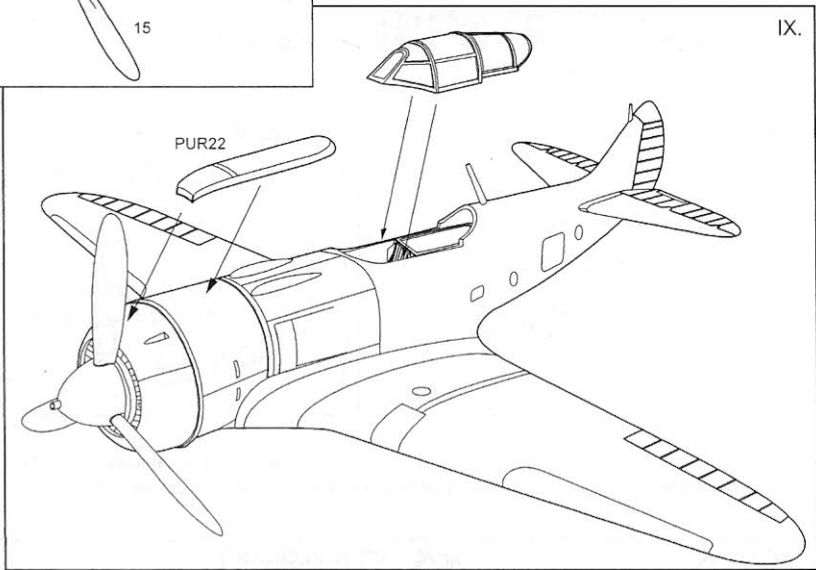

Camouflage & Decal application

La - 5FN, v.č. 39 21 19 23, 26.2.1946, letiště Piešťany, Slovensko.

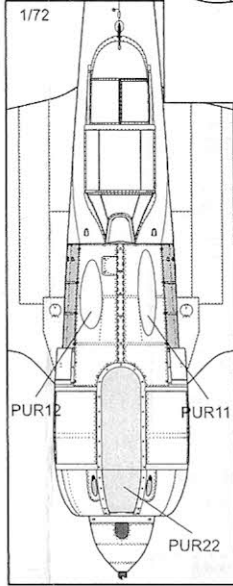
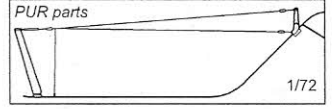
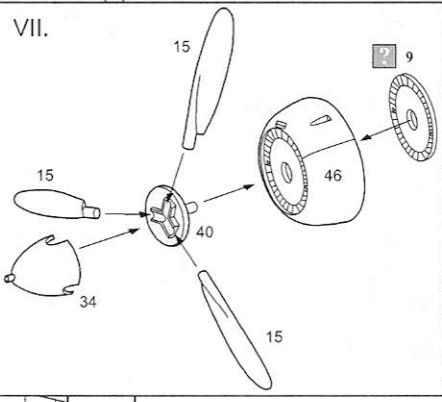
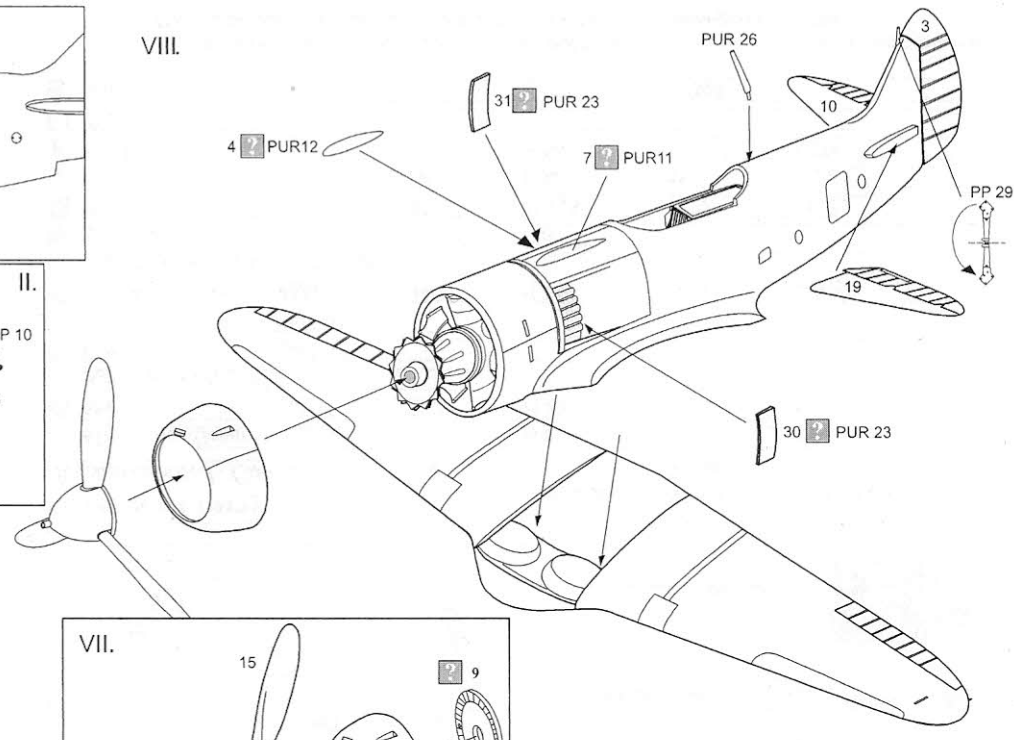
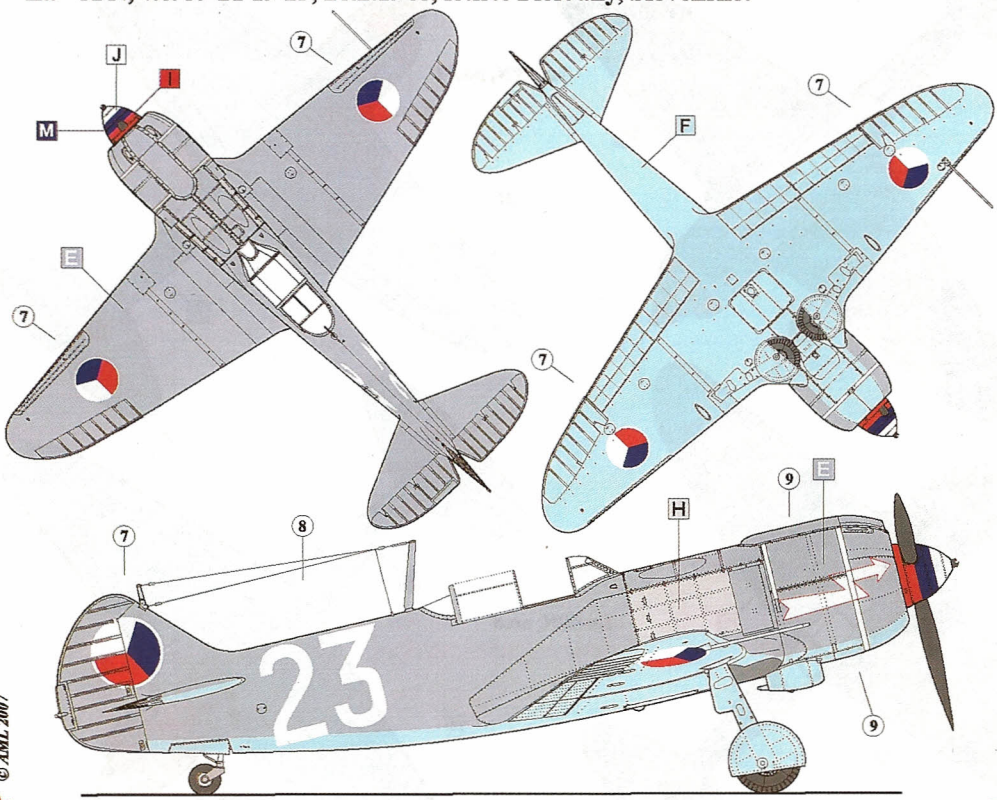

Děkuji Ing.Ladislavu Hladíkovi, Michalu Bradáčovi a Miroslavu Bílému z MBI Publications za pomoc při vzniku tohoto obtiskového aršíku.

Doporučené barvy						
Recommended Colours						
		F.S.	Humbrol	Gunze Sangyo	LIFECOLOR	
A	Matt Grass Green	AMT-4	4128	H 80	H 73	UA 146
B	Matt Black	AMT-6	7038	H 33	H 12	LC 02
C	Dark Green	RLM 71	4079	H 116	H 309, H 64	UA 052
D	Dark Grey	AMT-12				
E	Grey-Blue	AMT-11				
F	Matt Aircraft Blue	AMT-7	5450	H 65	H 67	UA 037
G	Light Blue Small Avion	2036.65				
H	Steel Grey			H 87		
I	Red	8913	H 153	H 327	LC 22	
J	White	7875	H34	11	LC 01	
K	Aluminium		H 56		LC24	
M	Blue					
N	Yellow	RLM 04	3538	H 154	H 413	UA 140
O	Black Green	RLM 70	4050	H 91	H 65	UA 051

NOTE: This above list references to Federal Standard /FS 595A / numbers do not include the prefix number. This just denotes the sheen of the colour e.g. 1= Gloss, 2= Semi-gloss, 3= Matt.

Lavochkin La - 5FN

AML 72 040
AML D 72 040
AML D 48 011

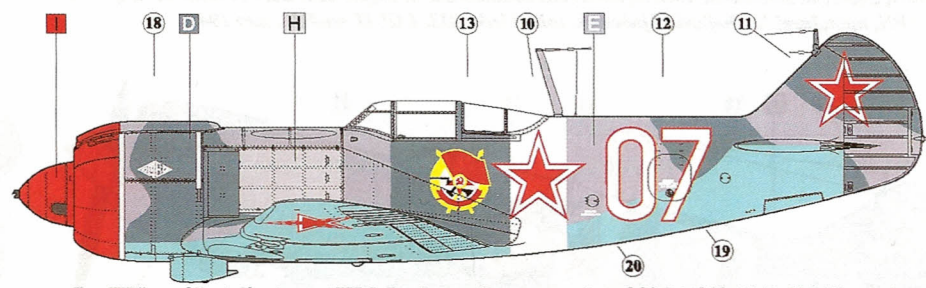

La-5FN, no.07, st. lieutenant Y.M. Lyubenyuk, commander of flight, 813. IAP, 12 kills, spring 1945.
La - 5FN, npor.Juryj Michajlovič Ljubeňuk, velitel letky 813. IAP, 11 sestřelů, jaro 1945.

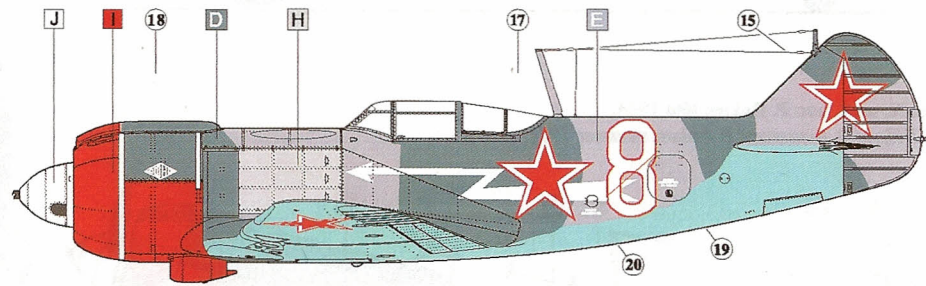

La-5FN, no.8, por. P. Rakov, léto 1944.
La-5FN, no.8, lieutenant P. Rakov, summer 1944.

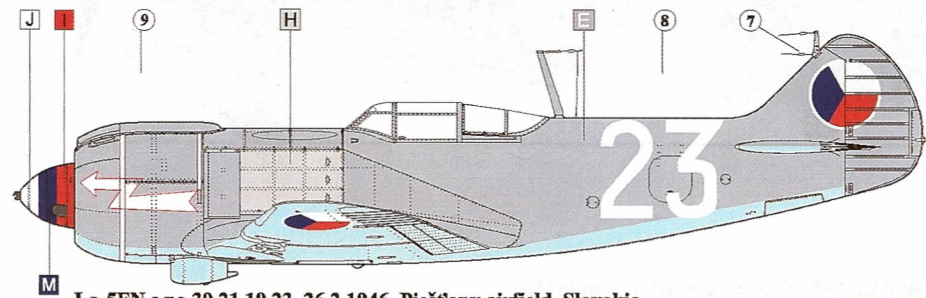

La-5FN, s.no.39 21 19 23, 26.2.1946, Piešťany airfield, Slovakia.
La-5FN, v.č.39 21 19 23, 26.2.1946, letiště Piešťany, Slovensko.

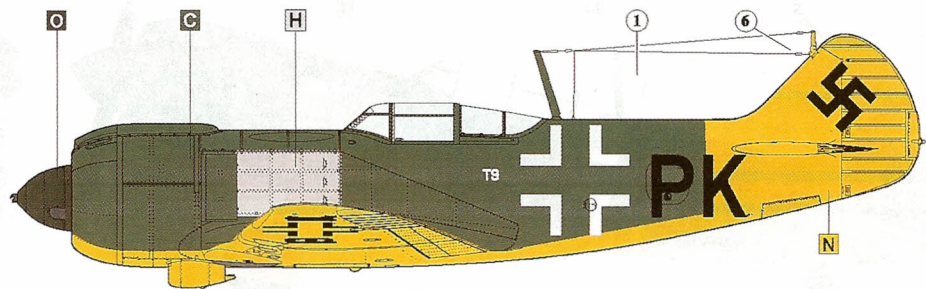

Kořistní La-5FN, T9+PK, Stendal, duben 1945.
A captured La-5FN, no.T9+PK, Stendal, Duben 1945.

La-5FN, no.07, st. lieutenant Y.M. Lyubenyuk, commander of flight, 813. IAP, 12 kills, spring 1945.
 La - 5FN, npor.Juryj Michajlovič Ljubeňuk, velitel letky 813. IAP, 11 sestřelů, jaro 1945.

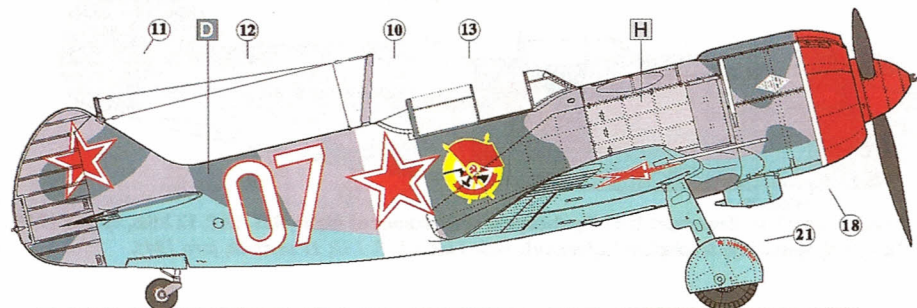

La-5FN, no.8, por. P. Rakov, léto 1944.
 La-5FN, no.8, lieutenant P. Rakov, summer 1944.

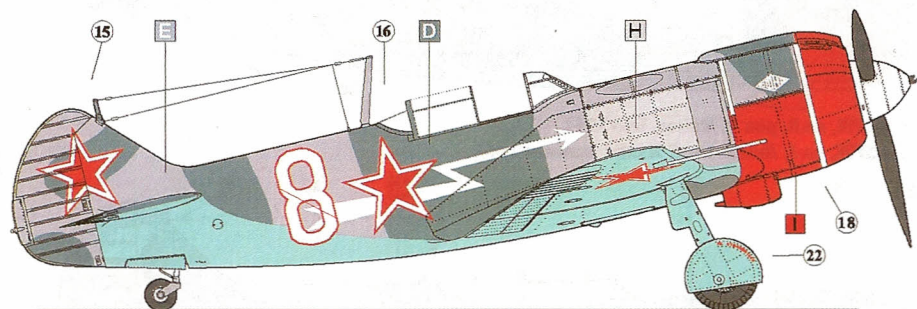

Kořistní La-5FN, T9+PK, Stendal, duben 1945.
 A captured La-5FN, no.T9+PK, Stendal, Duben 1945.

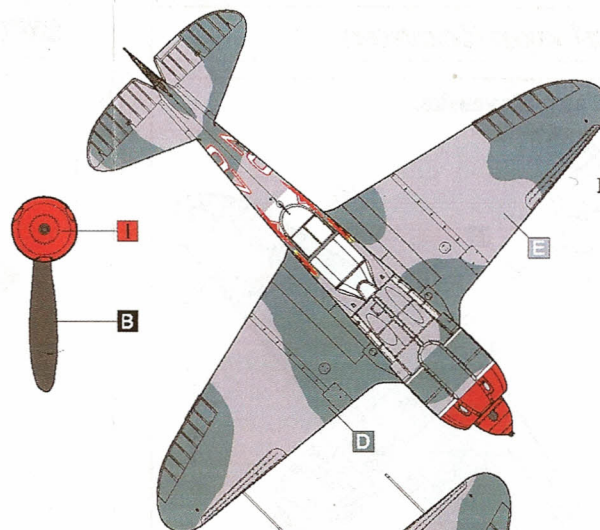
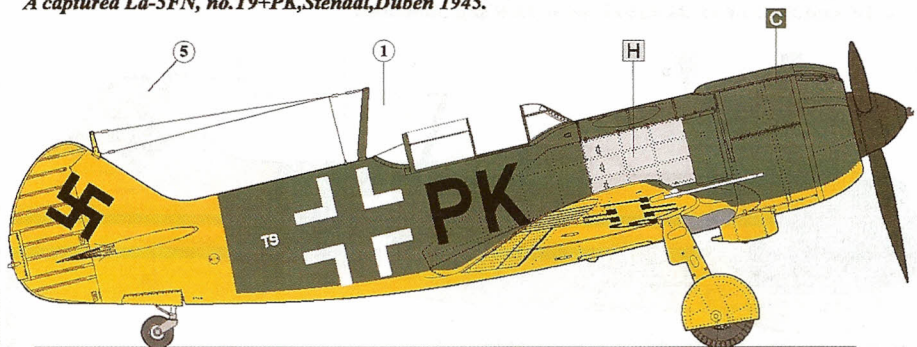

La-5FN, no.07

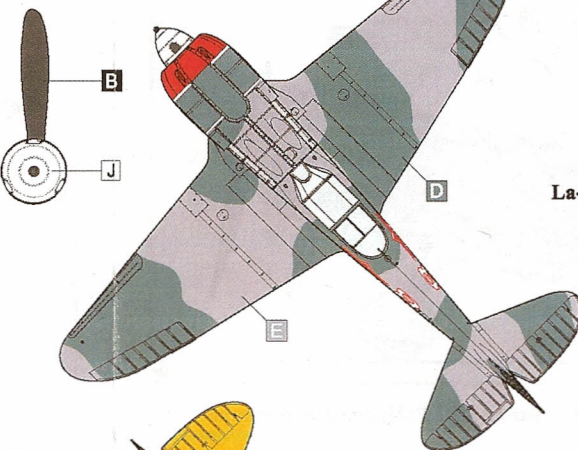
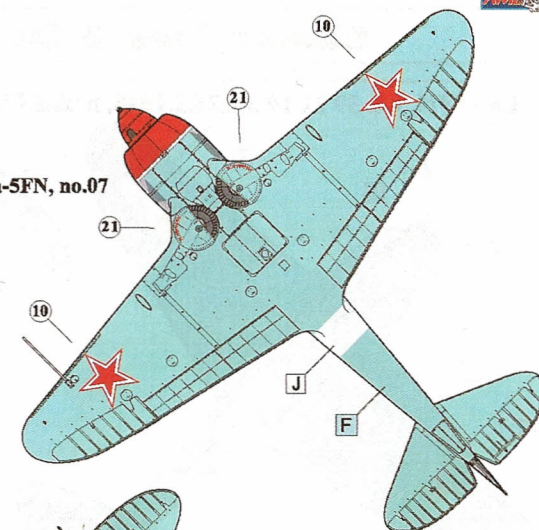

La-5FN, no.8

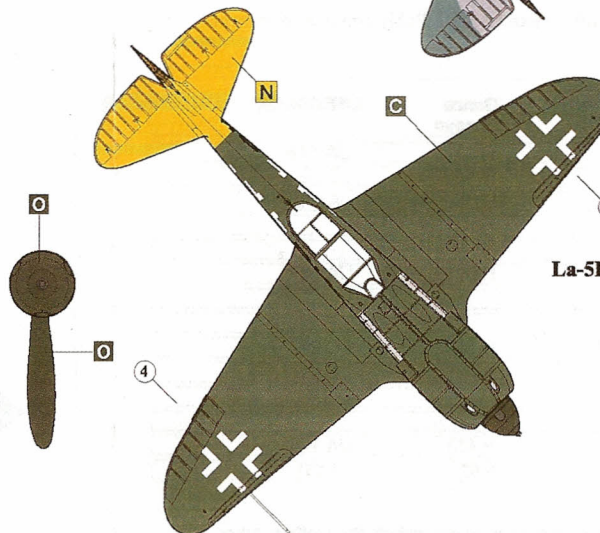
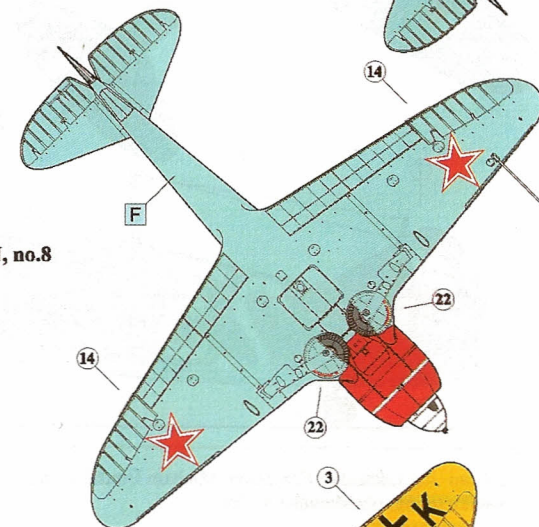

La-5FN, T9+PK

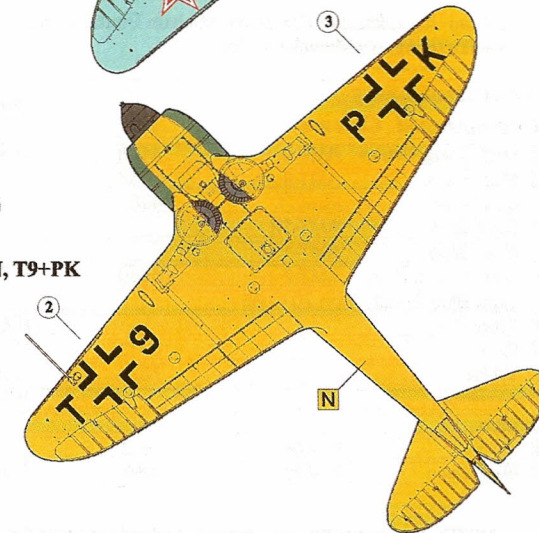

K letovým zkouškám byly spodní kryty podvozku demontovány.