

Fouga CM.175 Zéphyr



Cvičný proudový letoun Fouga Magister vznikl, ač se to může zdát neuvěřitelné, vývojem z celokovového motorizovaného větroňe C.M.8.15 konstruktérů P. Mauboussina a J. Szydłowského. Tento větroň s proudovým motorem poprvé vzlétl v roce 1949. Přes několik typů pokusných strojů, včetně dvoutrupého typu Gemeaux se oba konstruktéři dopracovali, podle požadavků Armée de l'Air, k typu CM.170 Magister. Všechny tyto spojovala koncepce ocasních ploch do "V". Nejprve byly objednány tři prototypy Magisteru. První z nich vzlétl 23.7.1952. Jeho vlastnosti byly dobré, ale nakonec byla postavena desetikusová ověřovací série, na které byly testovány úpravy, které se objevily na sériových strojích. Výjimkou byl druhý prototyp, který nesl klasické ocasní plochy dle požadavků vojáků. Nevykazoval ale žádné lepší vlastnosti než stroje s motýlkovými ocasními plochami. Proto byly všechny sériové stroje vyráběny dále s ocasními plochami do "V". Kromě normální cvičné/lehké bitevní verze se v sérii vyráběla jen navalizovaná verze Magisteru, označená Fouga CM-175 Zéphyr. Tu používalo pouze francouzské námořnictvo pro nácvik přistání na palubách letadlových lodí. Tato verze se lišila celkově zesílenou konstrukcí odolnou vůči zvýšené zátěži během přistávacího manévru a mezi hlavní vnější odlišnost patří zesílený podvozek, předělaná před, překrytí kabin odsunovatelné vzad a umožňující otevření kokpitu za letu a jeho případné rychlé opuštění během nepovedeného startu či přistání a samozřejmě také přistávací hák. Všechny ostatní verze Magisteru zůstaly v prototypech nebo v projektech.

Magistry zařadilo do výzbroje nejen francouzské Armée de l'Air. O letoun byl velký zájem a ve třech státech byl vyráběn licenčně. V roce 1958 začaly první kusy vyrobené v licenci dostávat letecké síly Finska a Německa. Oba státy před tím koupily část strojů přímo ve Francii. Licenční výroba v Izraeli dala první stroje v roce 1960. Izraelské stroje pojmenované Tzukit byly použity nejen k výcviku pilotů, ale s úspěchem zasáhly do několika izraelsko-arabských konfliktů. S úspěchem byly použity jako bitevníky. Pro bitevní akce byly montovány dva kulometry do předě a používala se různá podvěšená výzbroj, od bomb, až po neřízené rakety. To se týká všech Magisterů obecně.

V Evropě se dalšími uživateli stala Belgie, Rakousko a Irsko. Ovšem mnohem širší je seznam uživatelů v Africe, Asii a Jižní Americe. Mezi exotické uživatele, kteří byli bezesporu osloveni především nízkými provozními náklady Magisterů, patřilo například Alžírsko, Bangladéš, Biafra, Brazílie, El Salvador, Libye, Maroko, Togo či Uganda. Jako civilní létají Magistry i dnes.

rozpětí: 12,50 m (s přídatnými nádržemi), délka: 10,06 m, max. rychlost: 715 km/h, dolet: 1200 km, dostup: 11 000 m



The successful French Fouga CM.170 Magister lightweight jet trainer found its origins in a powered glider design of all-metal construction called the C.M.8.15 which sported a butterfly style tail empennage and was designed by P.Mauboussin and J.Szydłowski. This turbojet-powered glider flew for the first time in 1949 and during development of this design a number of test machines emerged including a unique twin-fuselage aircraft designated as the Gemeaux. The final stage of development of the C.M.8.15 glider led to the CM.170 Magister which was designed to meet an Armée de l'Air specification and like the powered gliders which preceded it this also sported a distinctive butterfly-type empennage.

An initial order for three prototype Magisters was made, the first of which made its maiden flight on 23 July, 1952 and as the performance was found to be acceptable this led to a follow on order for a batch of ten pre production aircraft. As per usual most of the prototype and pre production aircraft were used for testing of various components and improvements which would later be incorporated into full production airframes, the only exception to this was the second prototype which at the request of the military was modified to accept a standard fin and tailplanes. However as the flying characteristics in this configuration were found to be no better, all subsequent machines continued to feature the trademark butterfly tail. As well as serving with the French military the Magister was also an export success for Fouga which sold the type to a multitude of foreign operators and it was even built under licence in three countries. The first licence-built Magisters entered service with the air forces of Germany and Finland in 1958 where they also joined French-built Magisters and the third licence producer of the Magister was Israel, which produced its first aircraft in 1960. The Israeli Magisters were known locally as the Tzukit (or Thrush) and as well as basic training they were also used in the light-attack role where they proved successful during several of the Israeli-Arab conflicts. In the ground attack role the Magister could carry a pair of machine guns fitted in the nose section and various weaponry was mounted under the wings in the form of bombs and unguided rockets.

Within Europe the Magister was flown by France, Belgium, Austria and Ireland but there were also many other operators worldwide in Africa, Asia and South America, many of whom were no doubt attracted by its lightweight design and low operating costs. Among these far flung operators were countries such as Algeria, Bangladesh, Biafra, Brazil, El Salvador, Libya, Morocco, Togo and Uganda. Some Fougas are still flying these days, many of them in civilian hands.

Besides the standard trainer and light attack versions there was also a navalized variant of the Magister known as the Fouga CM.175 Zéphyr which was operated solely by the French Navy to carry out deck landing training for its trainee fast jet pilots. This airframe was stronger to cope with the rigours of deck operations and the main external differences were a set of strengthened undercarriage legs, a different nose section incorporating rear-sliding canopy hoods which could be opened in flight to aid swift exit in case of emergency during take off and landing at sea and of course it was also equipped with an arrestor hook. Further variants of the basic Magister design concept were also proposed but most remained on the drawing board as paper projects or did not proceed past the prototype stages.

Wingspan: 12,50 m (with wing-tip fuel tanks), Length: 10,06 m, Max. Speed: 715 km/h, Range: 1200 km, Ceiling: 11 000 m

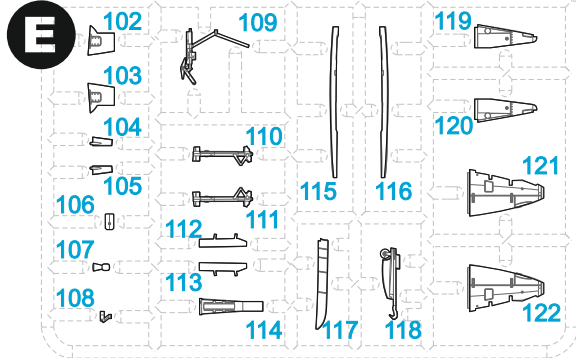
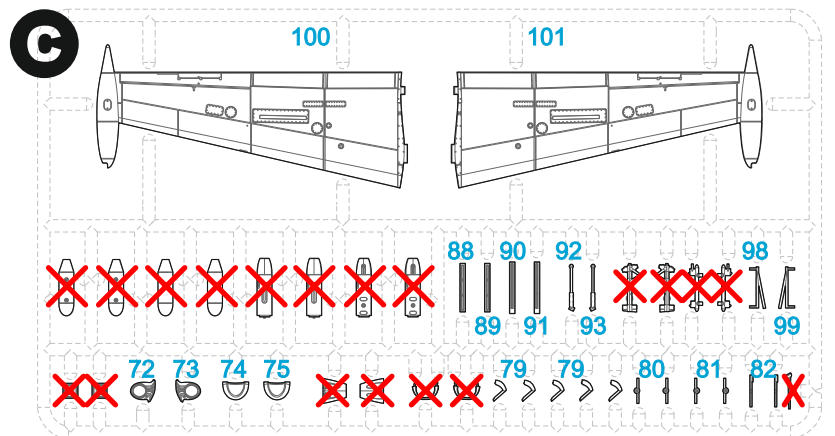
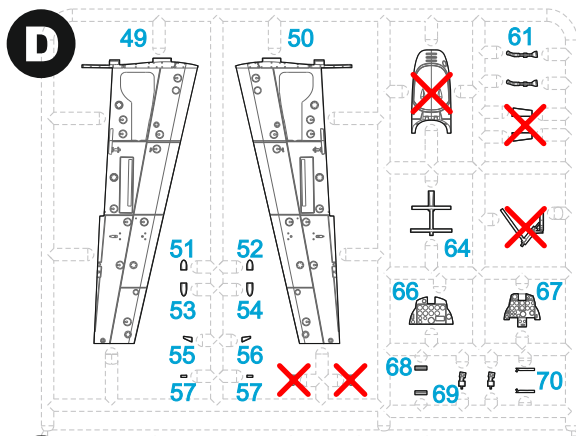
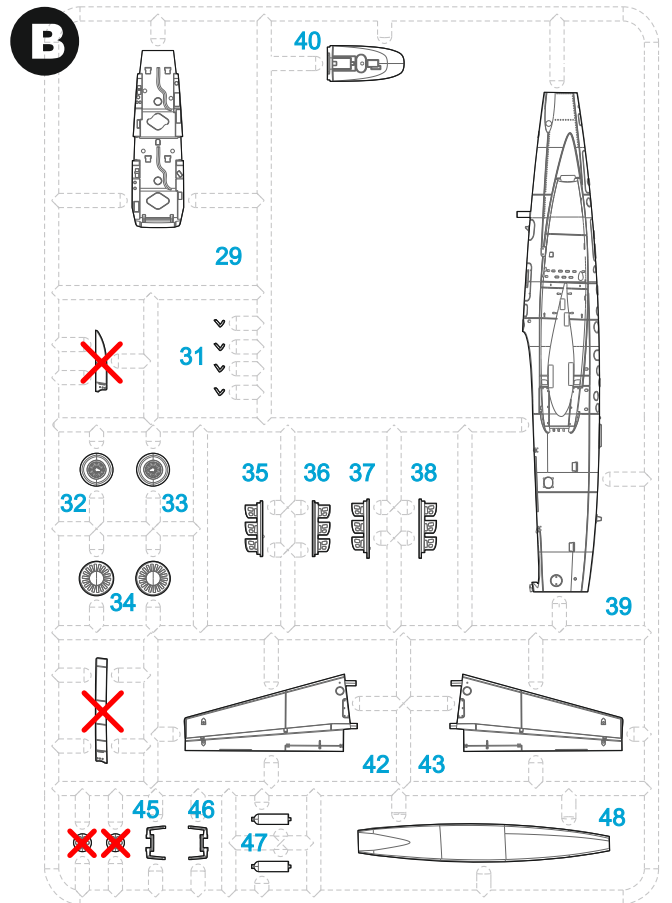
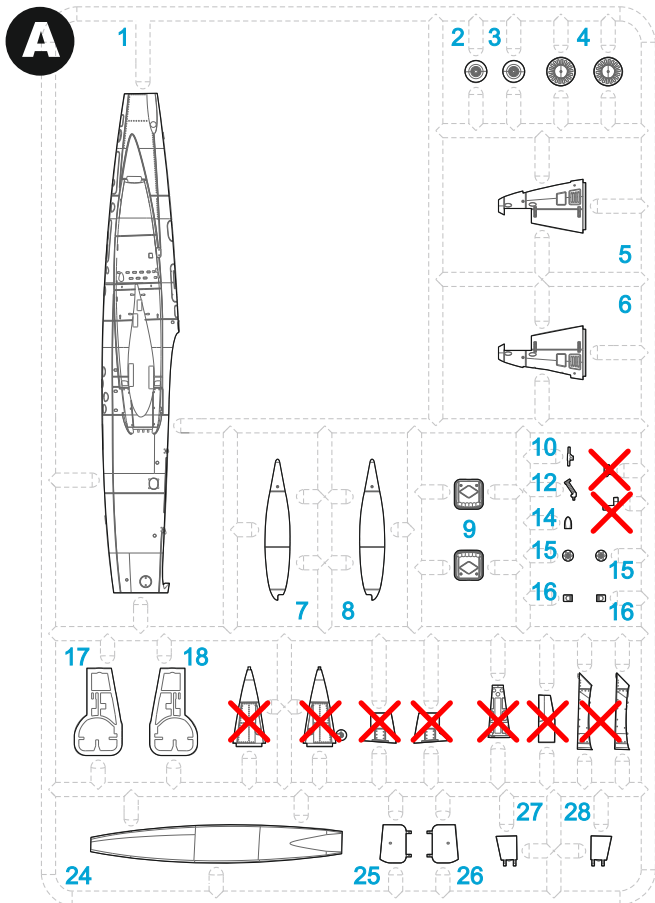

CLEAR Parts

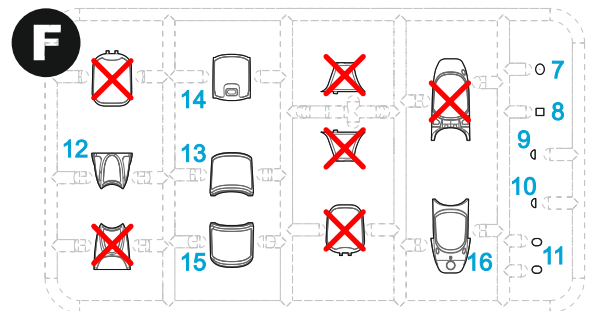

X = Tento díl nepoužít - Do not use this part

SYMBOLS

? MOŽNOST VOLBY
OPTIONAL
NACH BELIEBEN
OPTION

💧 POUŽÍT KYANOAKRYLÁTOVÉ LEPIDLO
INSTANT CYANOACRYLATE GLUE
ZYANOAKRYLÁTKLEBER
ADHÉSIF CYANOACRYLAT

↪ OHNOUT
BEND
BIEGEN
COURBER

✋ ZHOTOVIT NOVĚ
SCRATCH BUILD
FERTIGSTELLEN
ACHEVER

✂ ŘEZAT/VRTAT
CUT OFF/DRILL
ENTFERNEN
DETACHER

A NATRÍT
COLOUR
FARBEN
PEINDRE
GSI colours code

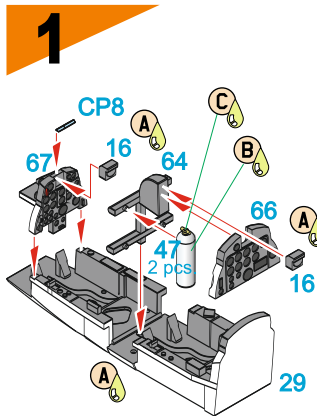

Kit part 67 + decal "A"



Kit part 66 + decal "B"

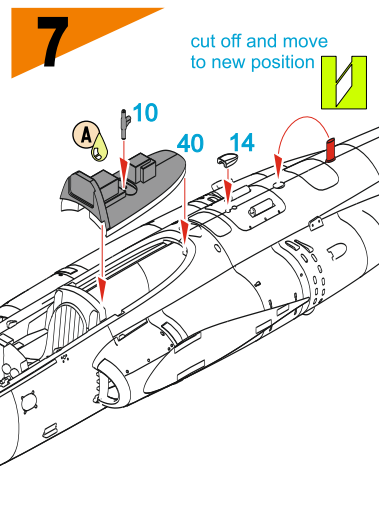
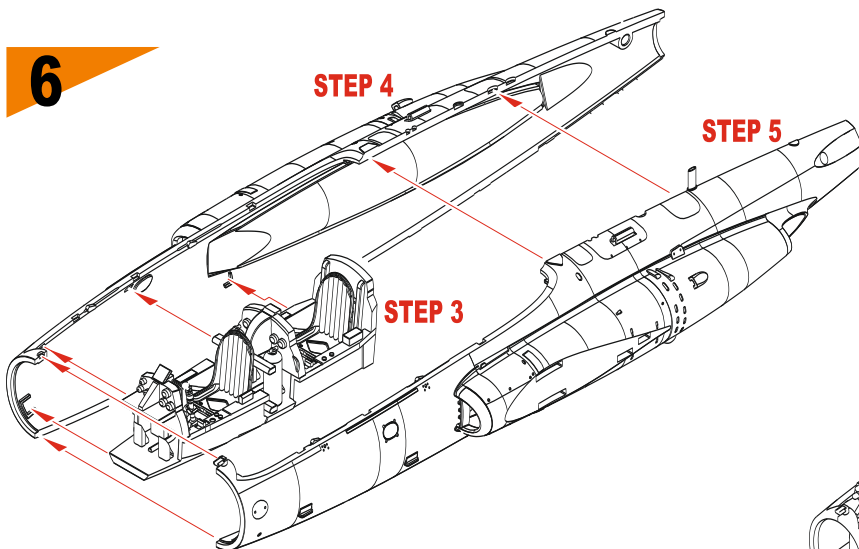
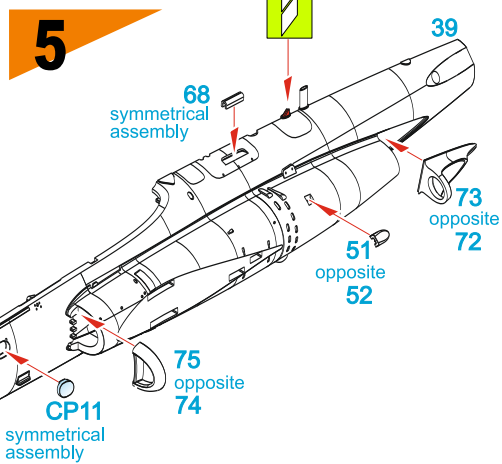
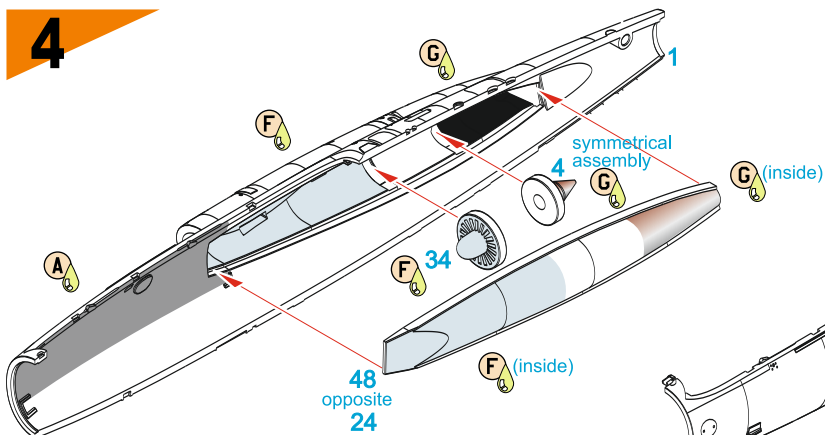
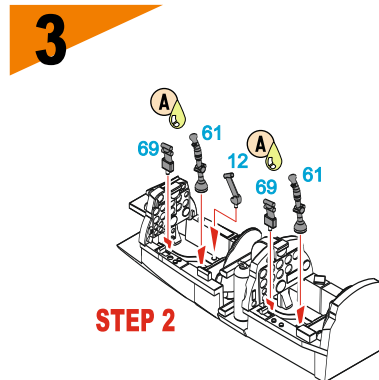
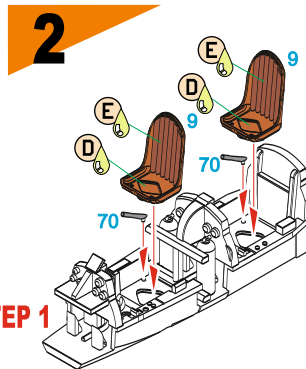
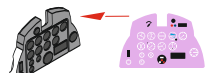

Barvy GUNZE/ GUNZE Colour No.

A	Černá / BLACK	H12/C33
B	Bílá / WHITE	H11/C62
C	Mosaz / BRASS	MC219
D	Hnědočervená / BAKELITE	H47/C41
E	Hnědočervená / LEATHER	M47/C41+H92/C49 80% 20%
F	Hliník / ALUMINIUM	H8/C8
G	Opálený kov / BURNT IRON	H76/C61
H	Žlutá / YELLOW	H4/C4
I	Světle žlutá / PALE YELLOW	H34
J	Červená / RED	H3/C3
K	Červená čirá / CLEAR RED	H90/C47
L	Modrá čirá / CLEAR BLUE	H93/C50
M	Barva pneu / TIRE BLACK	H77/C137

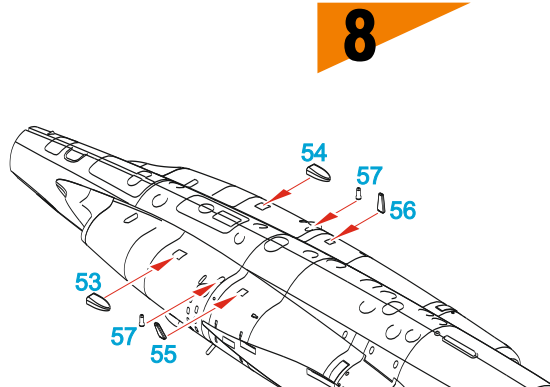

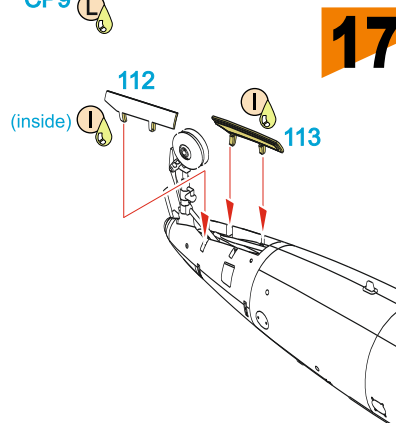
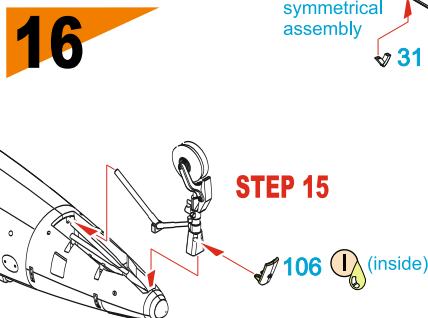
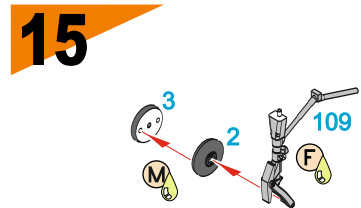
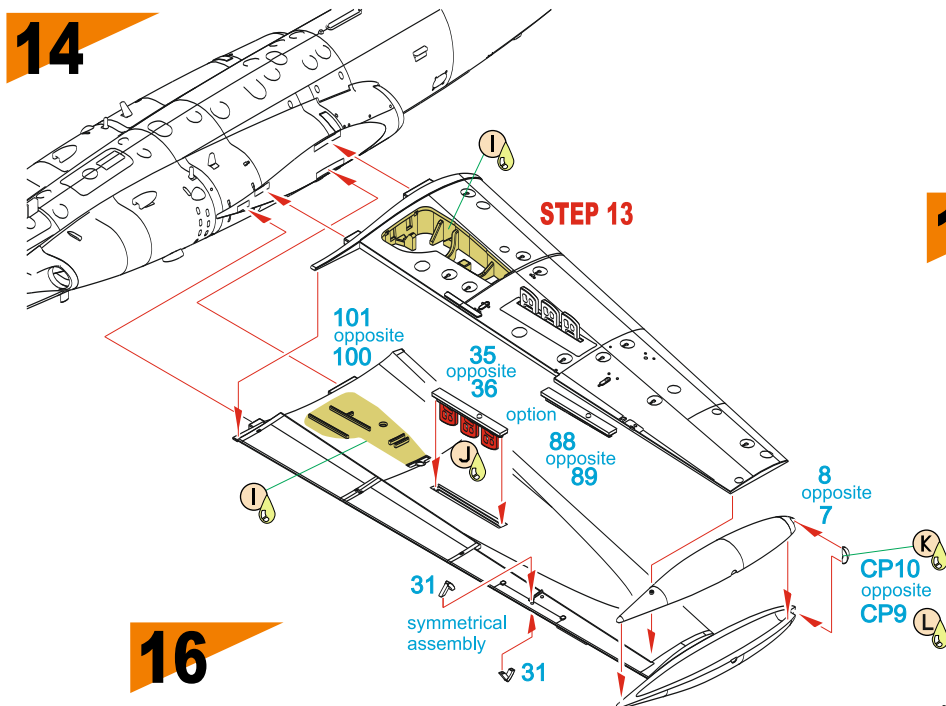
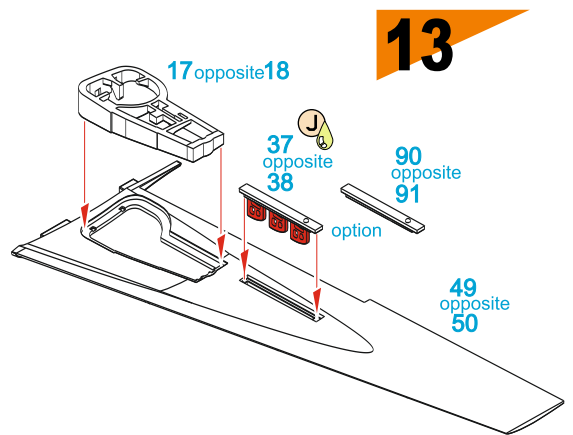
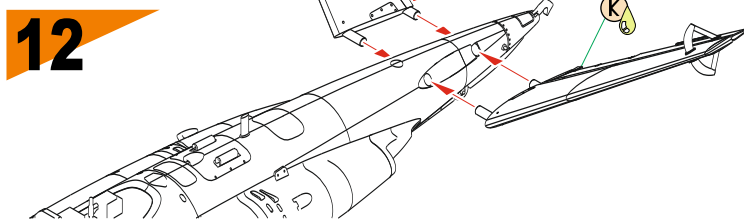
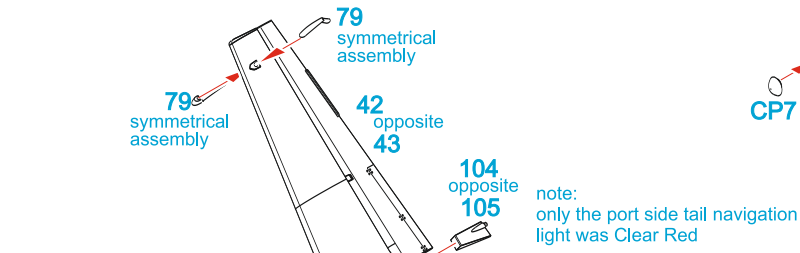
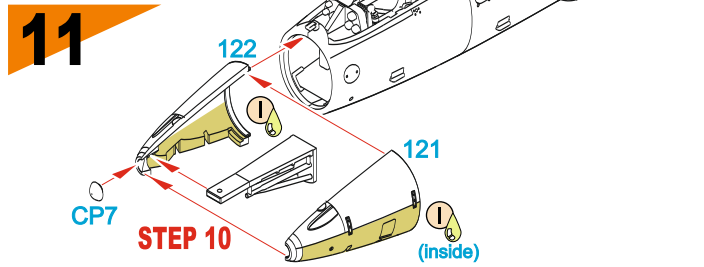
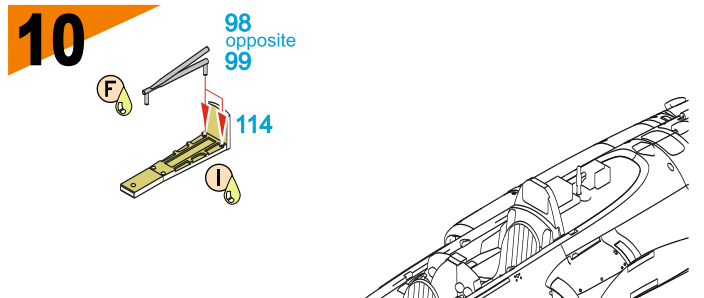
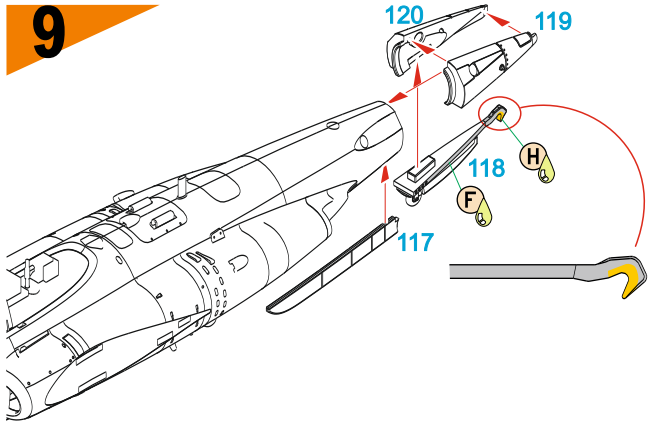

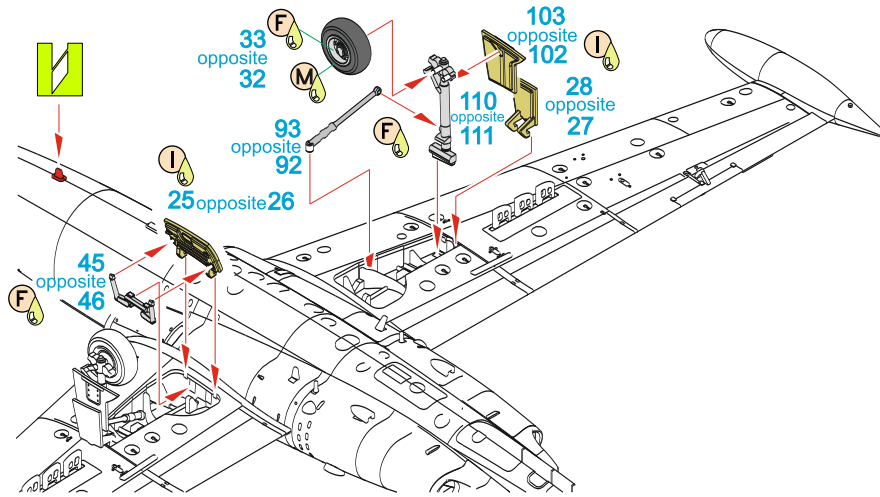
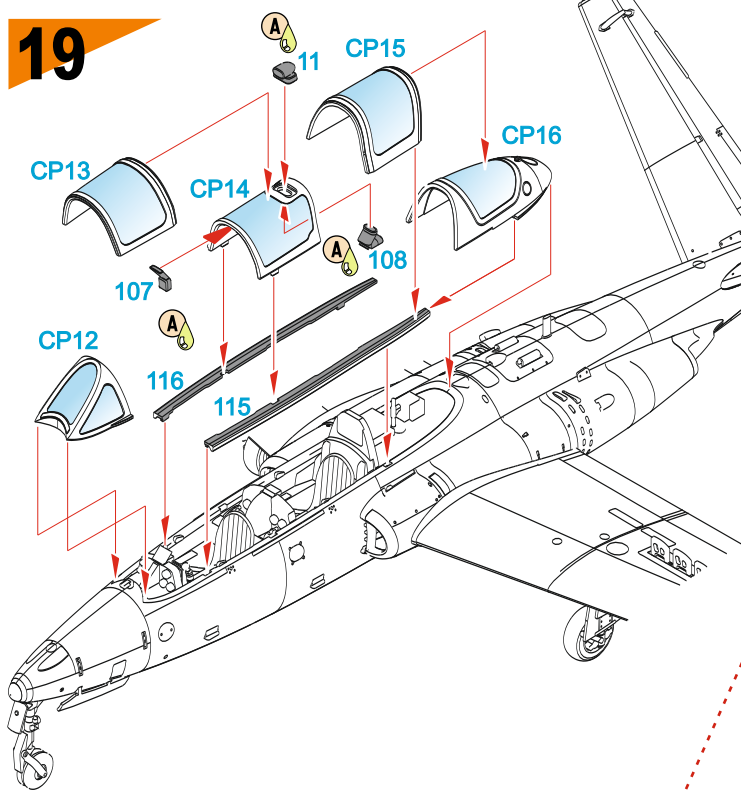
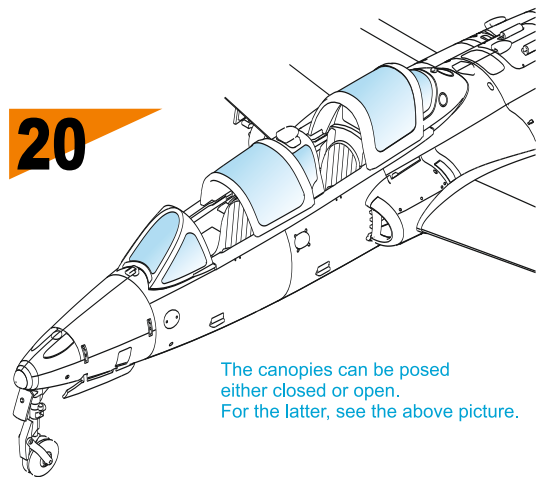
18**19****20**

The canopies can be posed either closed or open. For the latter, see the above picture.

Vzhled svého modelu CM.175 Fouga Zéphyr můžete vylepšit použitím detailních resinových sedaček a podvozkových kol ze CMK setů Q72227 a Q72228. Při stavbě modelu vám práci usnadní i samostatně prodáváná stříkací maska M72040 CM.175 Zéphyr MASK. Žádejte u svého obchodníka nebo objednávejte na našem e-shopu www.specialhobby.eu.

You can spruce up your CM.175 Fouga Zéphyr with these detailed resin seats and wheels (CMK sets 129-Q72227 and 129-Q72228). To make your build easier, we also offer the 100-M72040 CM.175 Zéphyr MASK, sold separately. You can ask about them at your local store or order them from us at www.specialhobby.eu.

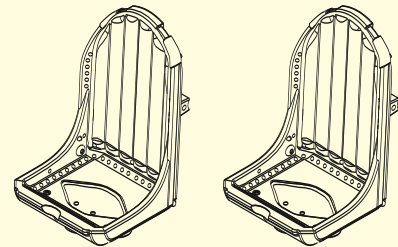
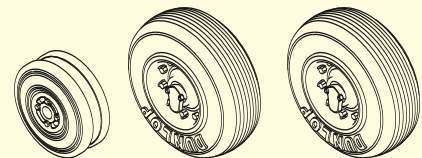
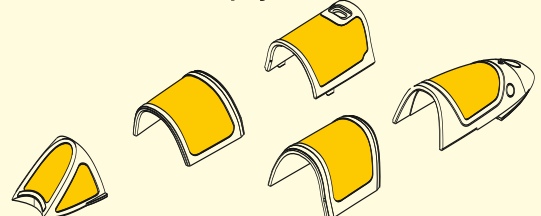
Q72 227 Resin Seats Set**Q72 228 Resin Wheels Set****M72040 CM.175 Zéphyr MASK**

Fouga CM.175 Zéphyr, s/n 4, stroj původně patřící Escadrille 59s ze základny francouzského námořnictva (BAN - Base d'Aéronautique Navale) Hyères, nyní je vystaven v Grimbergenu v Belgii.

Fouga CM.175 Zéphyr, s/n 4, ex-Escadrille 59s, BAN (Base d'Aéronautique Navale) Hyères machine, nowadays displayed at Grimbergen, Belgium.

CAMO. A

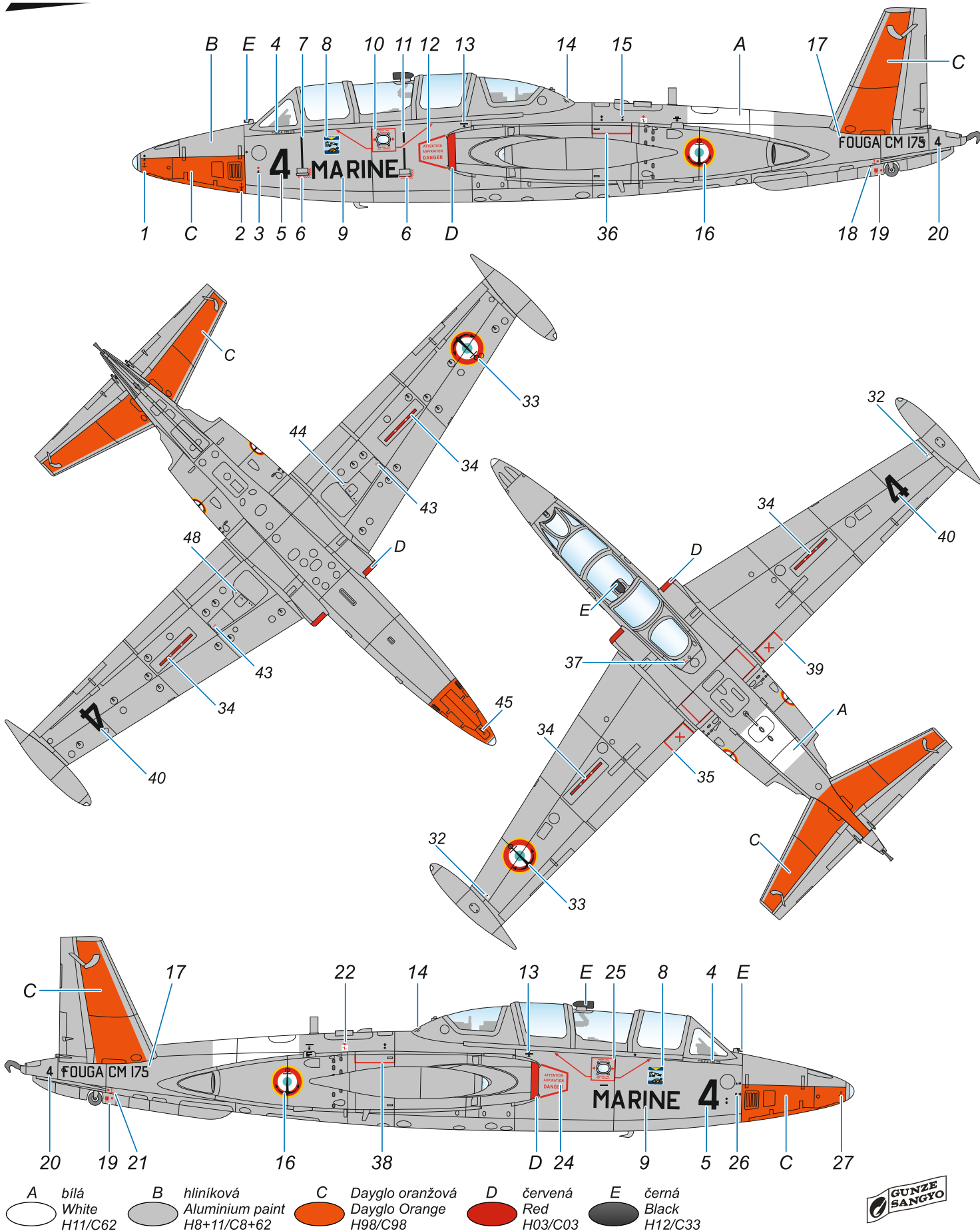

- | | | | | |
|-----------------------------------|--|--|------------------------------------|------------------------------------|
| A bílá
White
H11/C62 | B hliníková
Aluminium paint
H8+11/C8+62 | C Dayglo oranžová
Dayglo Orange
H98/C98 | D červená
Red
H03/C03 | E černá
Black
H12/C33 |
|-----------------------------------|--|--|------------------------------------|------------------------------------|



Fouga CM.175 Zephyr, s/n 11, Escadrille 59s, BAN Hyères, Francie. V tomto zbarvení Zephyry létaly mezi koncem 70.let a jejich vyřazením v 1994. Během celé doby jejich služby (1959-1994) provedly více jak 5000 přistání na palubách letadlových lodí Clemenceau, Foch a Arromanches.

Fouga CM.175 Zephyr, s/n 11, Escadrille 59s, BAN (Base d'Aéronautique Navale) Hyères, France, late 1970s until 1994. Fouga Zephyrs performed over 5.000 carrier landings on the deck of PA (Porte Avions - Aircraft Carrier) Clemenceau, Foch and Arromanches during the service which lasted from 1959 until their retirement in 1994.

CAMO. B

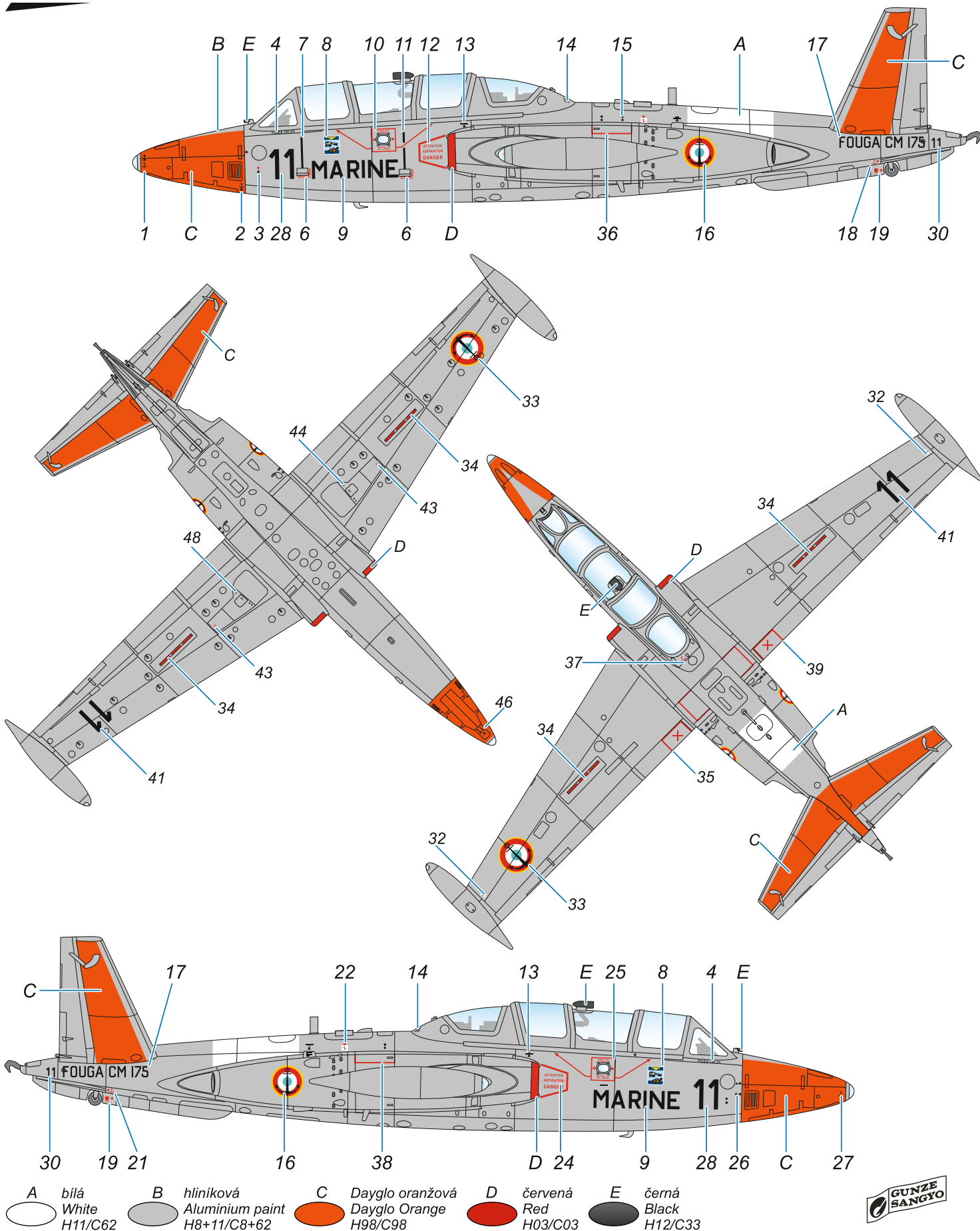

Fouga CM.175 Zéphyr, s/n 16, Escadrille 59s, základna francouzského námořního letectva v Hyères, Francie, od konce 70.let až do roku 1994.

Fouga CM.175 Zéphyr, s/n 16, Escadrille 59s, BAN (Base d'Aéronautique Navale) Hyères, France, late 1970s until 1994.

CAMO. C

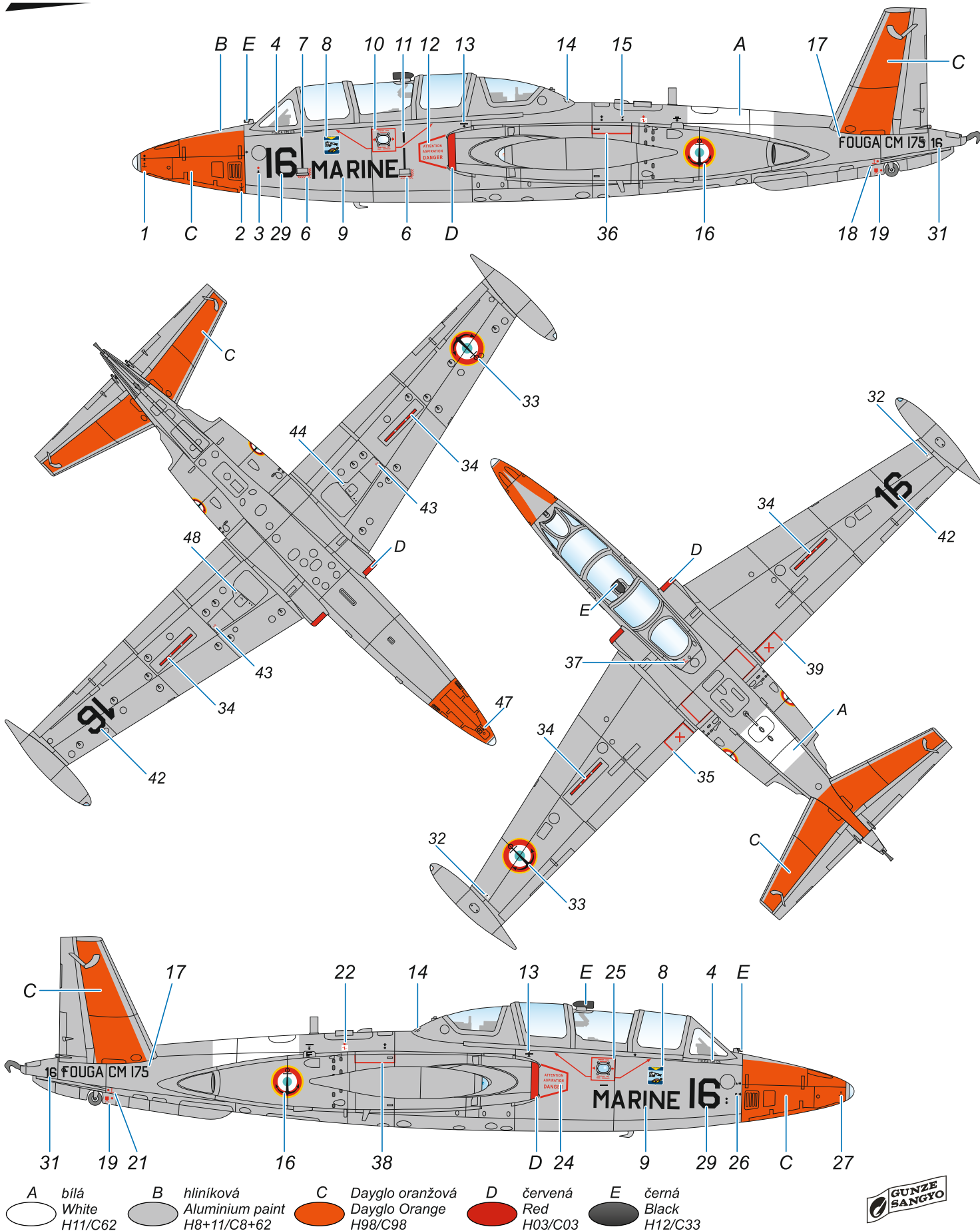

- | | | | | |
|-----------------------------------|--|--|------------------------------------|------------------------------------|
| A bílá
White
H11/C62 | B hliníková
Aluminium paint
H8+11/C8+62 | C Dayglo oranžová
Dayglo Orange
H98/C98 | D červená
Red
H03/C03 | E černá
Black
H12/C33 |
|-----------------------------------|--|--|------------------------------------|------------------------------------|

Fouga CM.175 Zéphyr, 57.S-23, Escadrille 57s - École de Chasse de la Marine (škola stíhacích pilotů francouzského námořnictva). V letech 1959 - 1960 na základně Khouribga v Maroku, od 1960 do 1962 v Port Lyautey, Maroko.

Fouga CM.175 Zéphyr, 57.S-23, Escadrille 57s - École de Chasse de la Marine. Based at Khouribga, Morocco, 1959-1960 and Port Lyautey, Morocco, 1960-1962.

CAMO. D

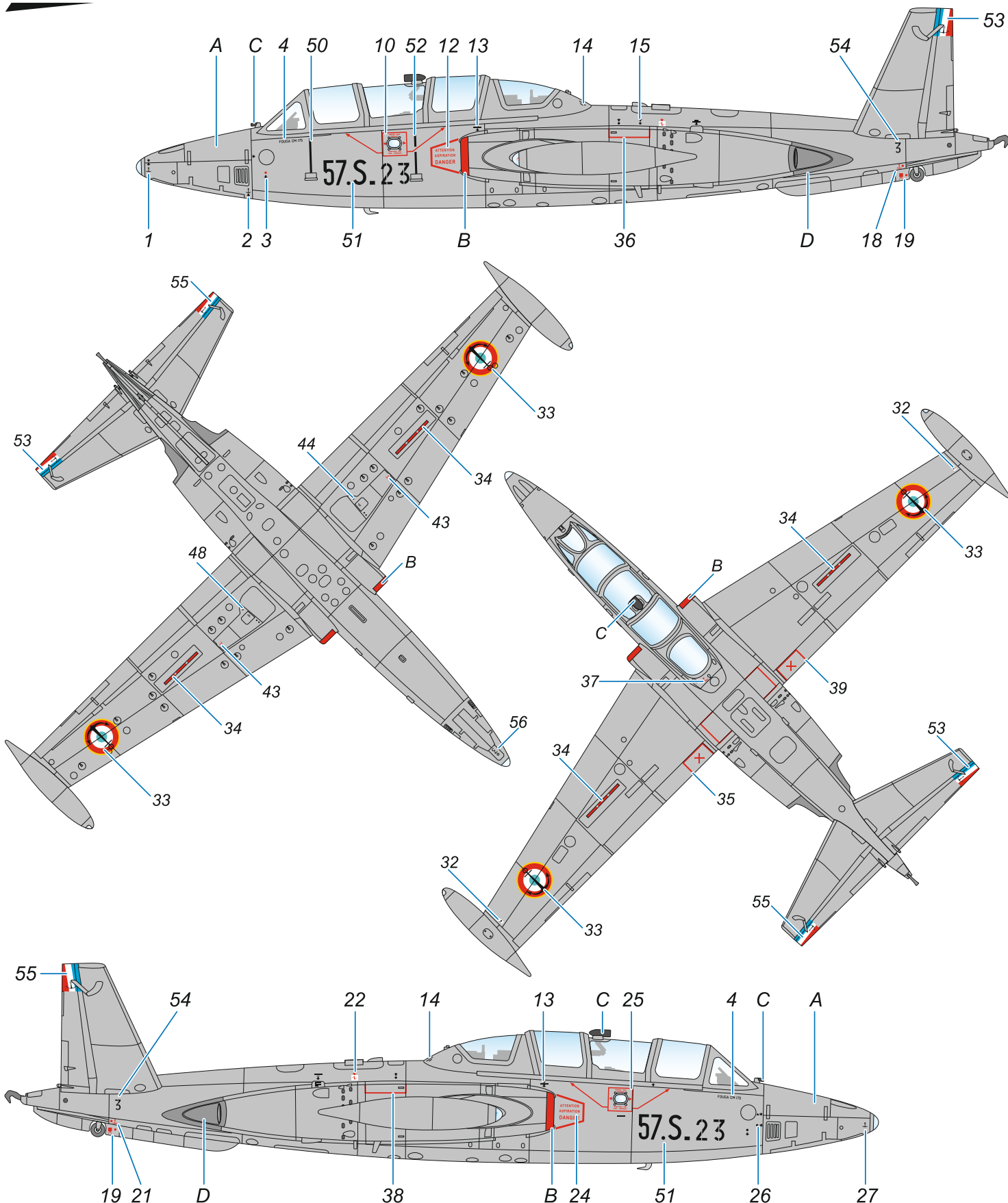

- | | | | | | | | |
|----------|---|----------|---------------------------|----------|---------------------------|----------|------------------------------------|
| A | hliníková
Aluminium paint
H8+11/C8+62 | B | červená
Red
H03/C03 | C | černá
Black
H12/C33 | D | tmavý kov
Dark Metal
H76/C61 |
|----------|---|----------|---------------------------|----------|---------------------------|----------|------------------------------------|



ATTRACTIVE 1/72 SCALE MODELS & SETS

SH72414 Mirage F.1 Duo Pack & Book

M72013

Mirage F.1 Single Seater Mask

Special MASK

M72014

Mirage F.1 Two Seater Mask



SH72417 SMB-2 Super Mystère / Sa'ar Duo Pack & Book

M72001

SMB-2 Super Mystere Mask

Special MASK



F-14A Tomcat CMK sets for Academy kit



7452
F-14A Tomcat
Cockpit



7453
F-14A Tomcat
Port Side
Cannon
Installation



7454
F-14A Tomcat
Port Engine

AH-1G/Q/S CMK sets for Special Hobby and Revell kit



Q72330
AH-1G Early
Emerson Electric
TAT-102 (single
weapon) turret



Q72331
AH-1G
Emerson
Electric M28
(dual weapon) turret



Q72338
AH-1Q/S
Hughes M65
Telescopic
Sight Unit



F72349
AH-1
Sitting pilots
(2 figures)
and ground
crew
(1 figure)

Special HOBBY



facebook.com/specialhobby

WWW.SPECIALHOBBY.EU | WWW.CMKKITS.COM

CMK
CZECH MASTER'S KITS



SH72358

A.W. Meteor NF MK.11



SH72360

A.W. Meteor NF MK.12



SH72424

Gloster Meteor F.8 Prone Pilot

1/72 SH72364



M72027 **Special MASK**
A.W. Meteor NF Mk.14 Mask

A.W. Meteor NF Mk.14 'The Last of Night Fighters'

1/72
SH72431



Supermarine Sea Otter Mk.I/ASR Mk.II 'Foreign Service'

1/72 SH72451 **SF-260 Duo Pack & Book**

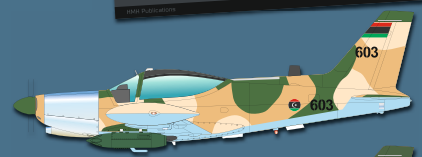
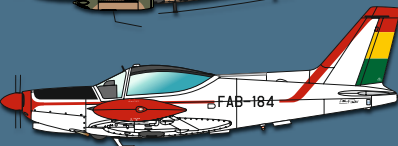
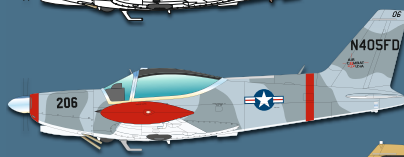
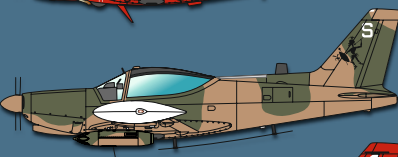
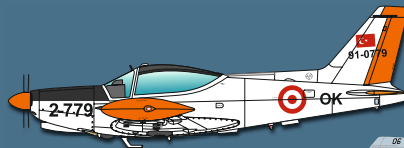
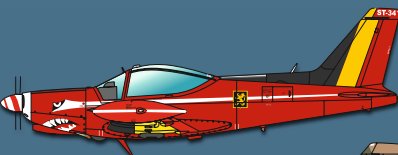

Special HOBBY

[facebook.com/specialhobby](https://www.facebook.com/specialhobby)
WWW.SPECIALHOBBY.EU | WWW.CMKKITS.COM

