

Messerschmitt Bf 109F

Conversion set for HASEGAWA Bf 109G-6 kit

RESIN PARTS

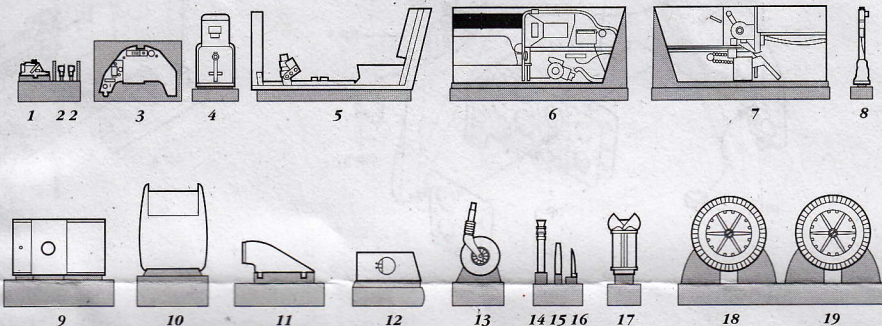
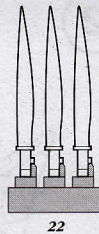
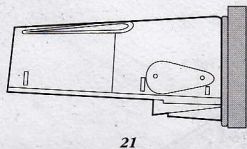
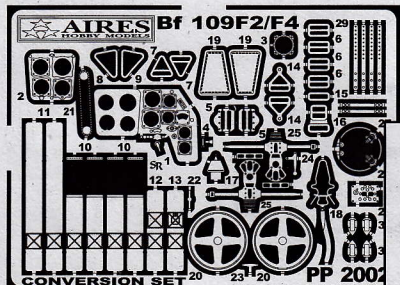
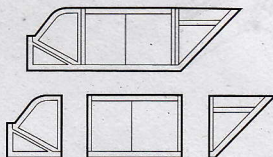

PHOTO-ETCHED METAL PARTS



CANOPIES



1

? *OPTION* Only F-1/F-2 variants
VOLBA Pouze varianty F-1/F-2

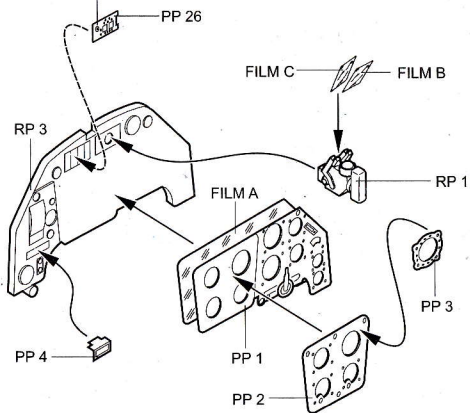

3

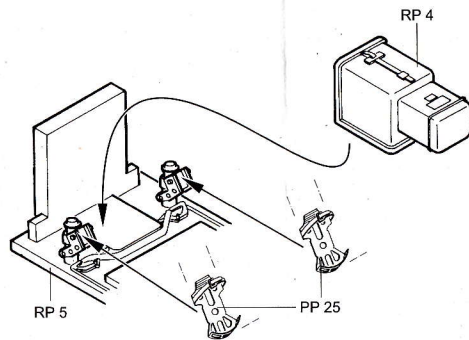

2

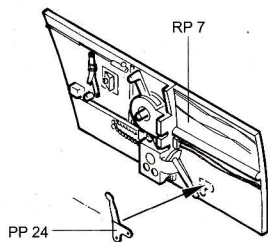

4

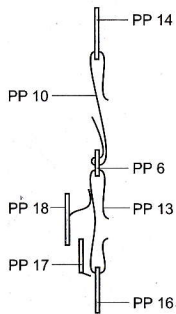
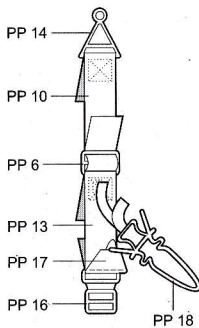

5

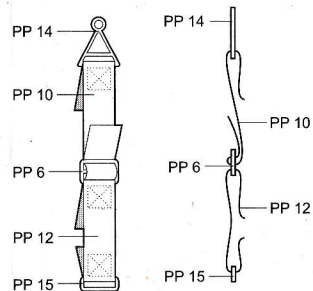

6

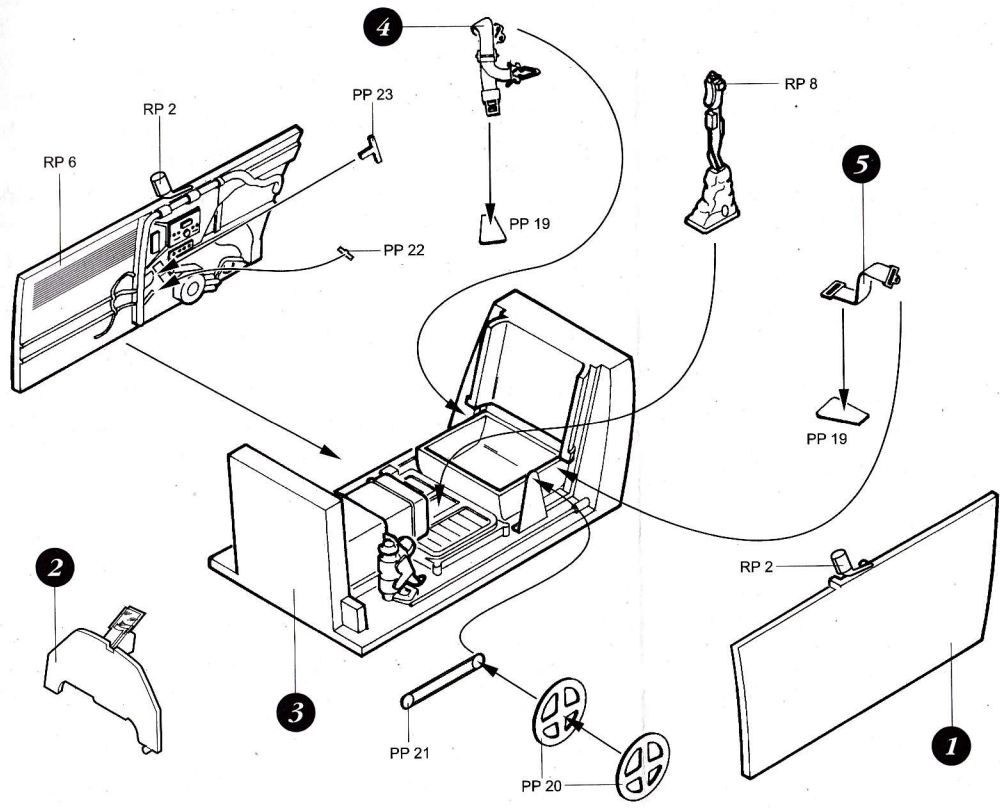

7

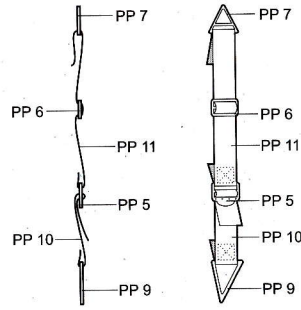

8

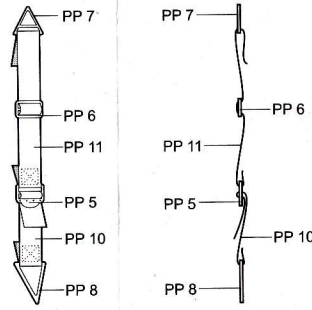

9

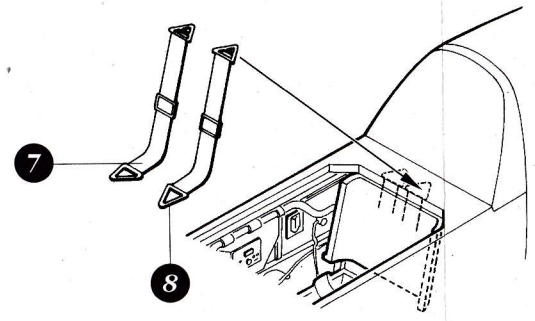

10

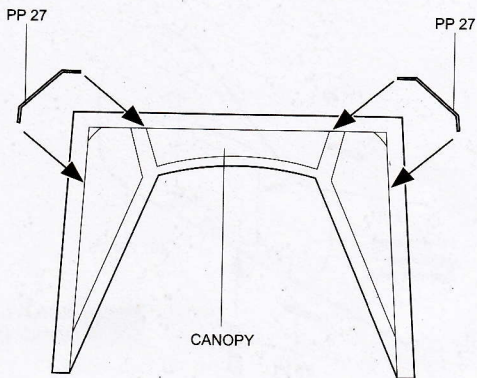

11



*OPTION
VOLBA*

Some variants
Některé varianty

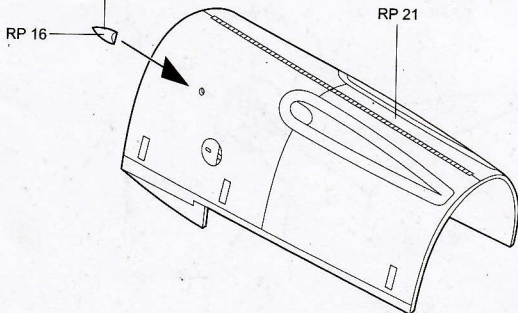

12

MIRROR ASSEMBLY
ZRCADLOVÁ MONTÁŽ

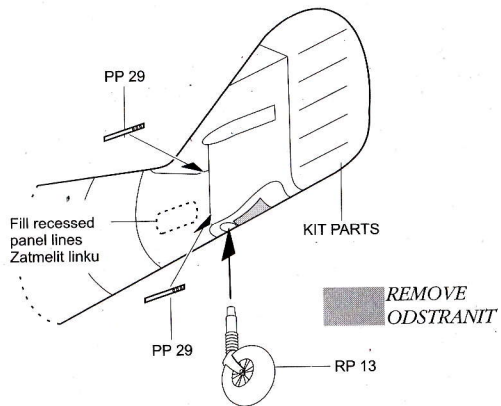

13

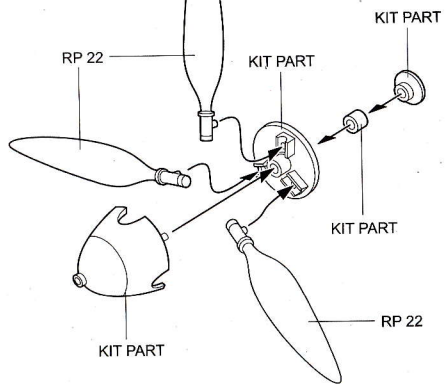

14

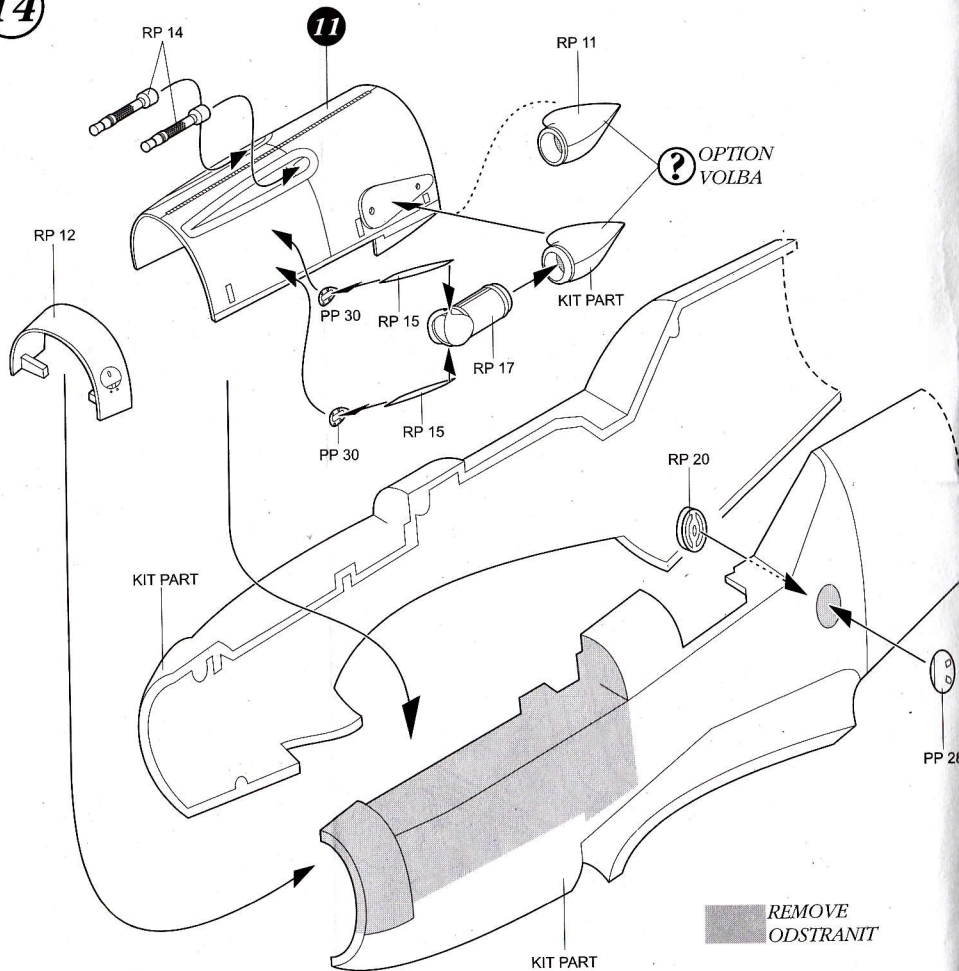

15

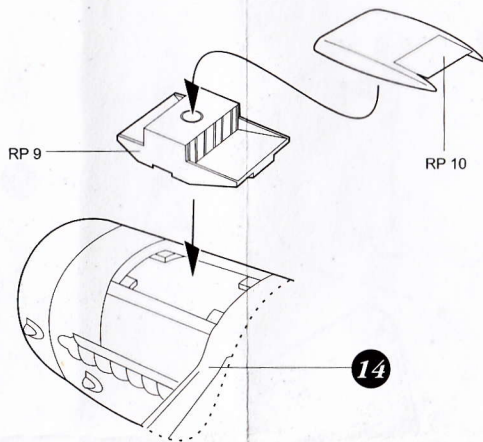

16

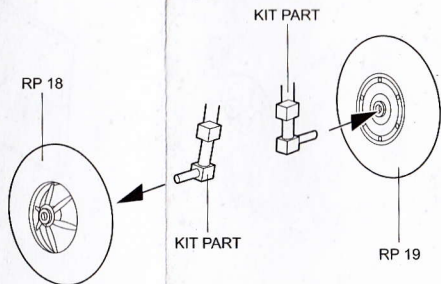

Researching the facts for this kit was interesting and enlightening. We found that the wealth of information available was at times, very controversial.

It seems, among many other facts, that some F-2 were retrofitted to F-4 standards.

Many authoritative books, at times caption one A/C as an F-2, and the next book calls it an F-4. Of course this could be a case of mistaken identification.

We suggest you look at pictures of the selected A/C and follow the features of that particular airplane. Happy Modelling

Warning: Thinning of the plastic parts and dry-fitting of the assembly needed!
Upozornění: Nutno zeslabit některé plastové díly stavebnice!
Před lepením zkontrolujte dopasování dílů!