

Option4: 64th Anti-Tank Regt RA,78th Infantry Division Italy 1944 Camouflage Scheme-Overall Colour SCC5 Light Mud with SCC14 Blue-Black camouflage pattern and White undershading.
1944年在意大利作战之英国第78步兵师64反坦克旅下属车辆，全车涂沙灰色附加蓝黑斑状迷彩。

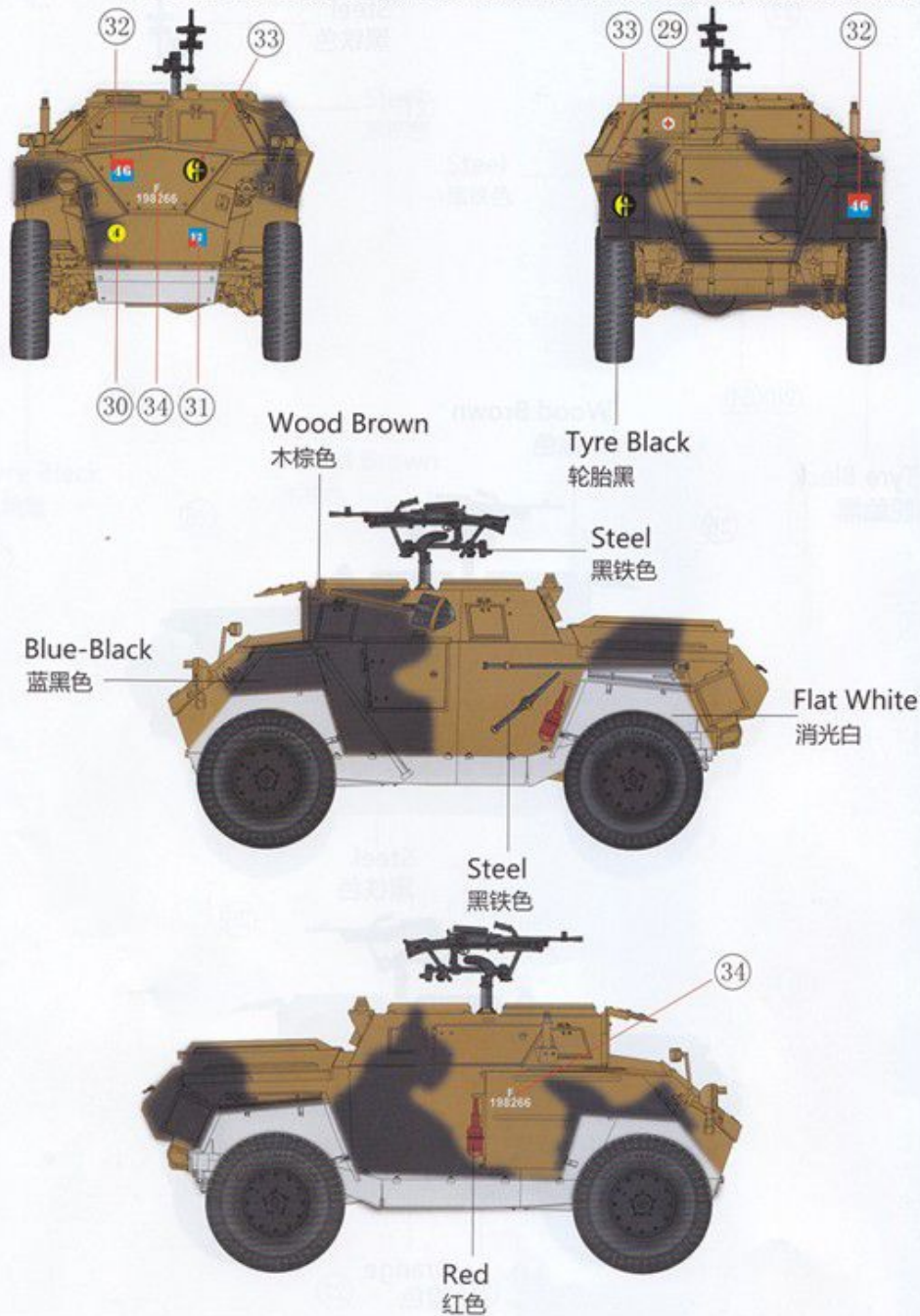

BRONCO

Bronco Models

WWII British Humber MK.I Scout Car & AFV Crew Set

英国‘亨伯’MK.I轻型侦察装甲车与英联邦军乘员组



The Humber Scout Car entered service in 1943, probably too late to see service in the Tunisian campaign, but was then widely used in Italy and North-West Europe. As it was a Scout Car, it was used by many different units, including the Royal Armoured Corps, Armoured Guards battalions, as well as by the Royal Engineers, Royal Artillery and at the various Formation Headquarters. In some cases it seems that units 'tweaked' the establishment to put the larger Humbers in the HQs, with their Dingos being used at Troop level. Users included Liaison Officers, Intelligence Officers, Signals Officers, Technical Adjutants, and Commanding Officers as their 'run-around' when not mounted in their tank. It was frequently used in Formation HQs as an un-allocated 'pool' vehicle. It was also used by Britain's allies, including the Canadians and Poles. It has already been noted that production was stopped in 1945, as the war in Europe ended. A decision had been made to continue to use the smaller but generally more capable Dingo as the Scout Car for the post-war army, and thus most of the Humber Scout cars were scrapped or sold off. They did continue to serve in Malaya until the early 1950s, being used by Brigade HQs and Armoured Car regiments, some converted to mount twin MGs with a spotlight between, for anti-ambush purposes. They were used by the French, Belgian, Dutch and Danish armies, the French apparently using them in Indo-China in the war with -the Viet Minh. A few surviving examples can be found in museums, and a small number of beautifully restored examples survive to grace military vehicle rallies.

Information & research by Dick Taylor

‘亨伯’侦察车正式于1943年投入服务，虽然太迟未能参与北非战役，但却广泛使用于稍后之意大利及西欧战线。由于此车性能超卓为英军各不同部队如装甲兵、炮兵、工程兵等争相采用。除英国本身外当时还供应其他盟国如加拿大及波兰等部队使用。

1945年中欧战结束后，‘亨伯’侦察车也正式停止生产。随后此车部份遭解体或出售至丹麦、法国、荷兰、比利时及其他英联邦国家如马来西亚等部队使用。在上世纪50年代中南半岛之战中，此车也曾替法军立下不少汗马功劳。直到现在各国之军事博物馆中还可见到此车之展品保存得非常好状态。

ILLUSTRATION 图示说明：

Caution: This kit contains a lot of small accurate parts, please carefully to read before to assembly.

此套件包含不少精细零件，请在制作前先翻阅说明书了解清楚。

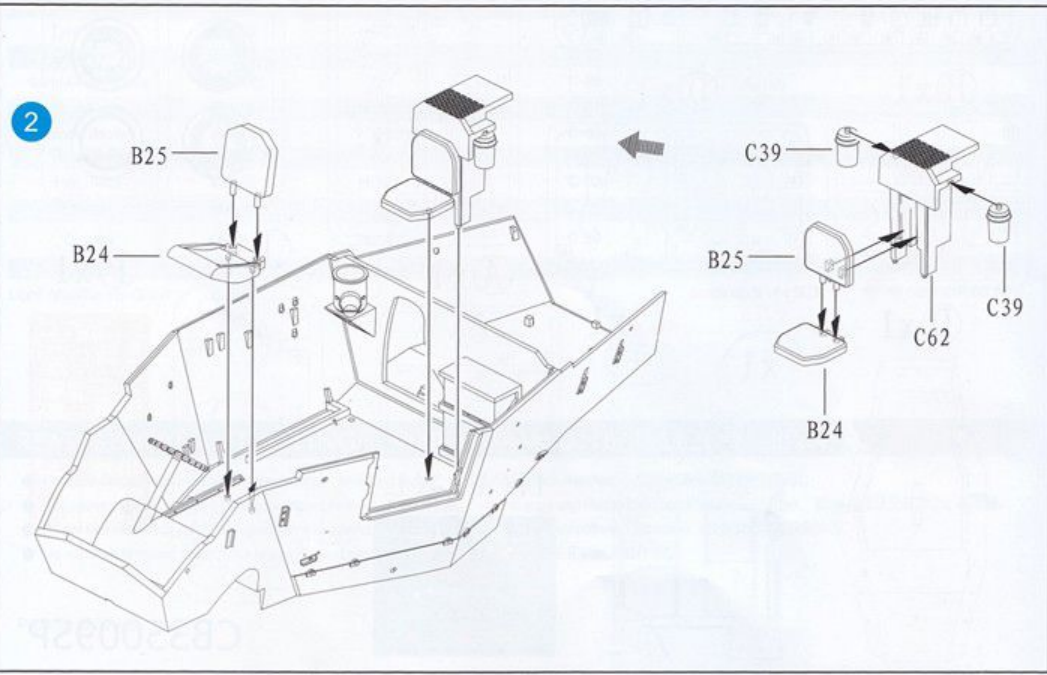
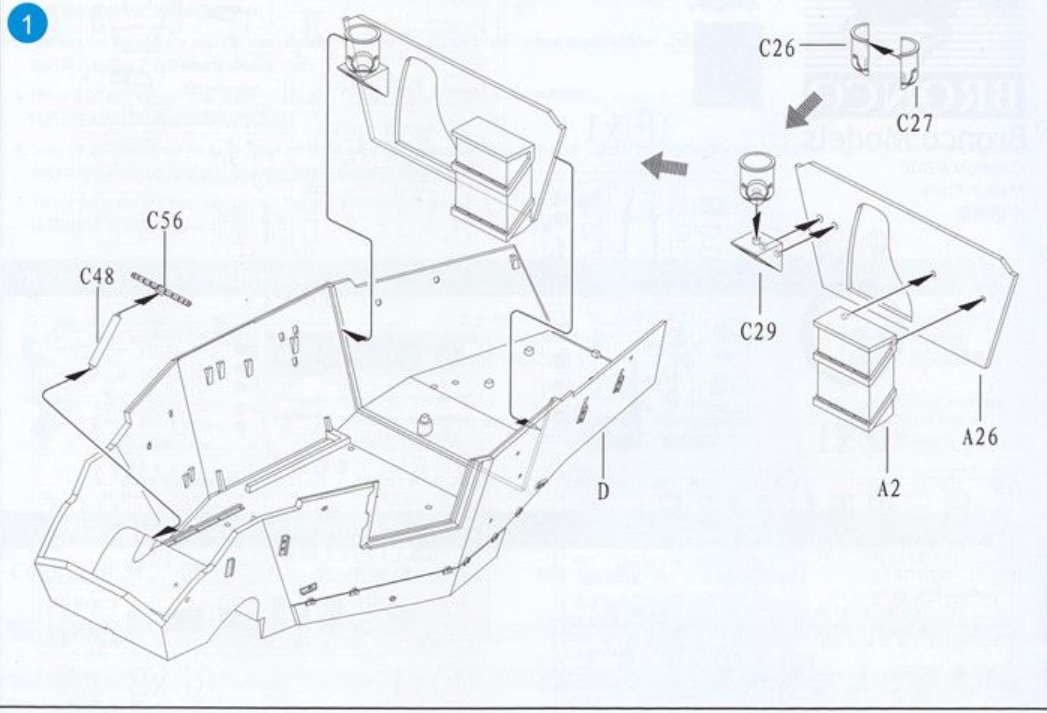
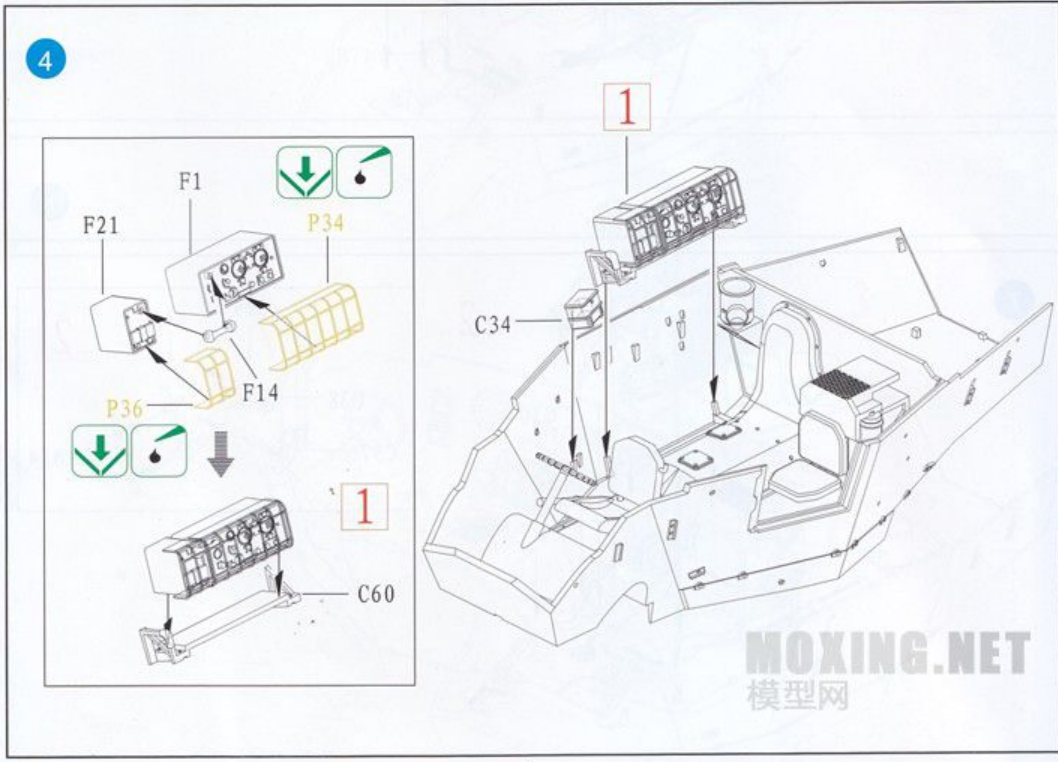
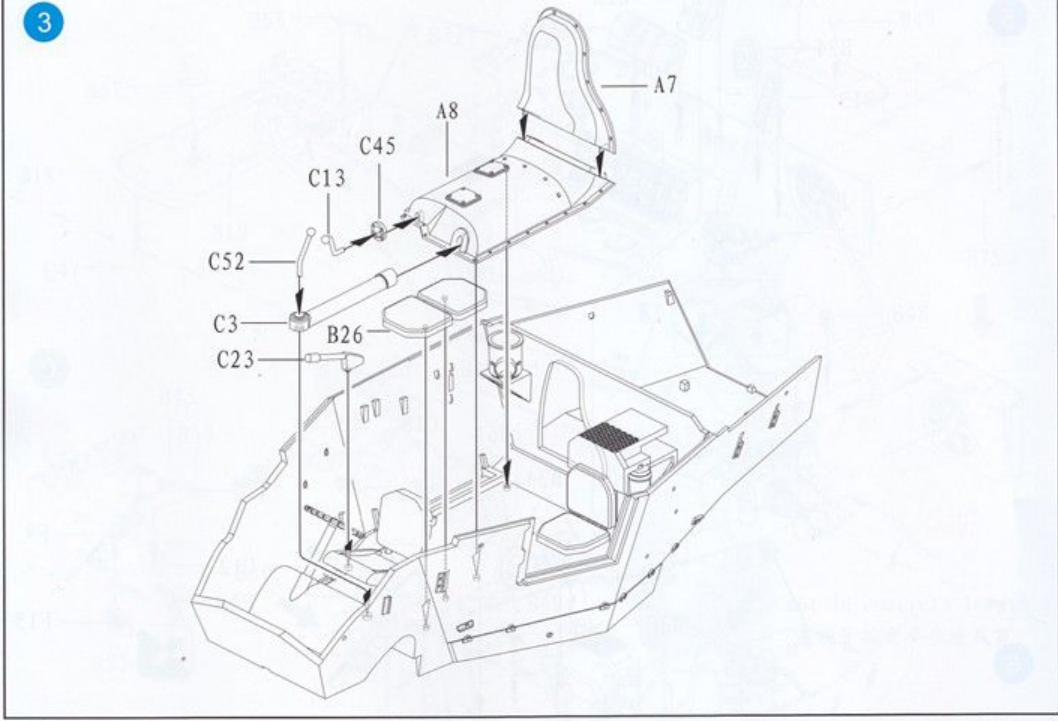

ILLUSTRATION 图示说明：



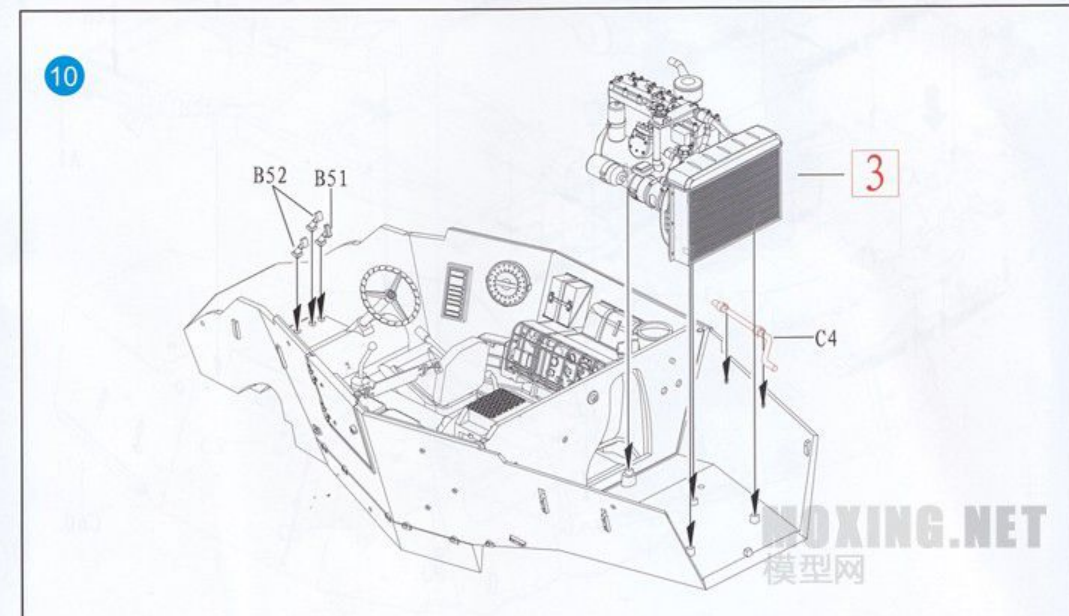
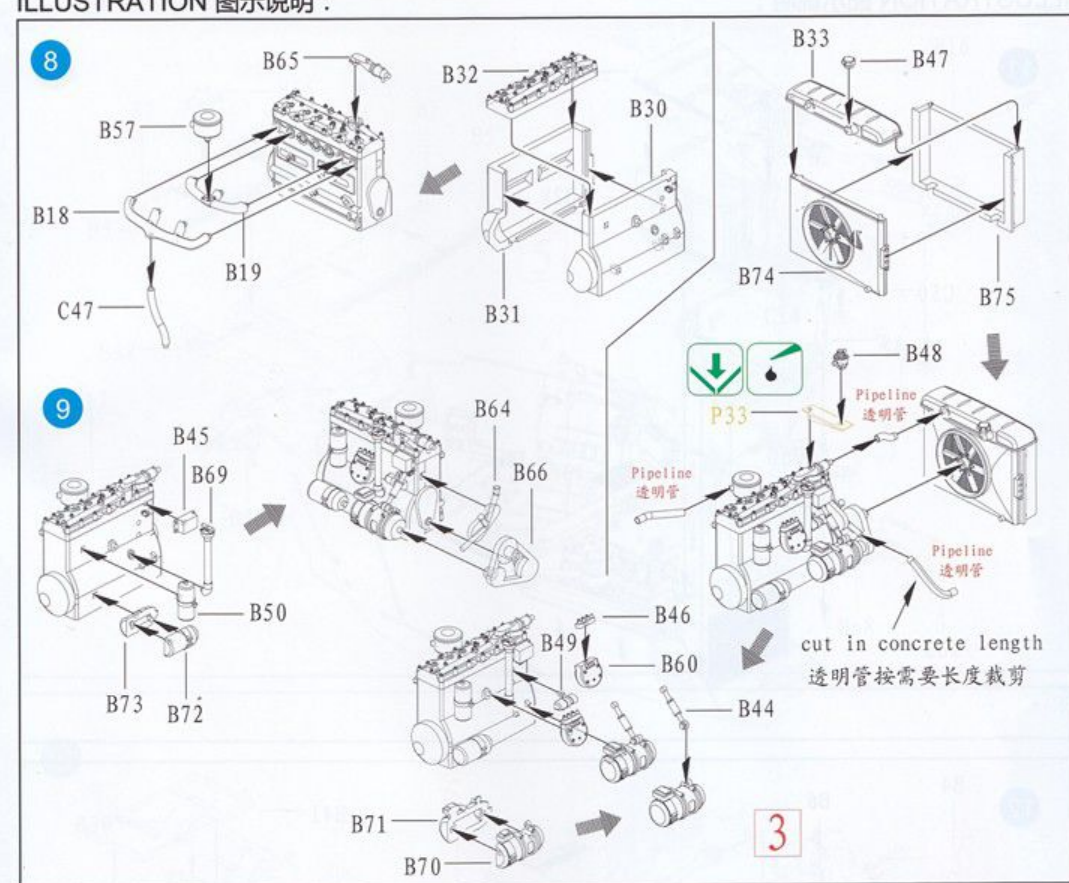
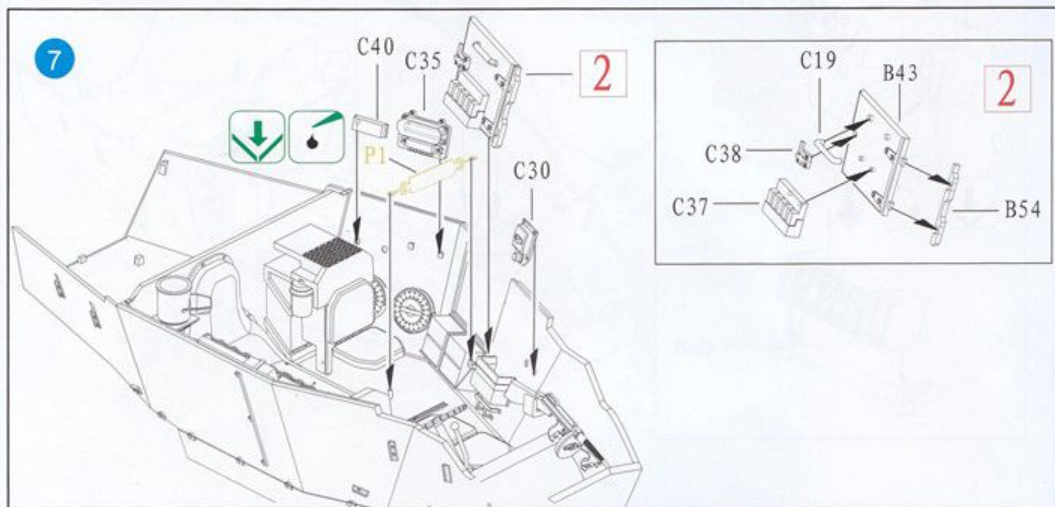
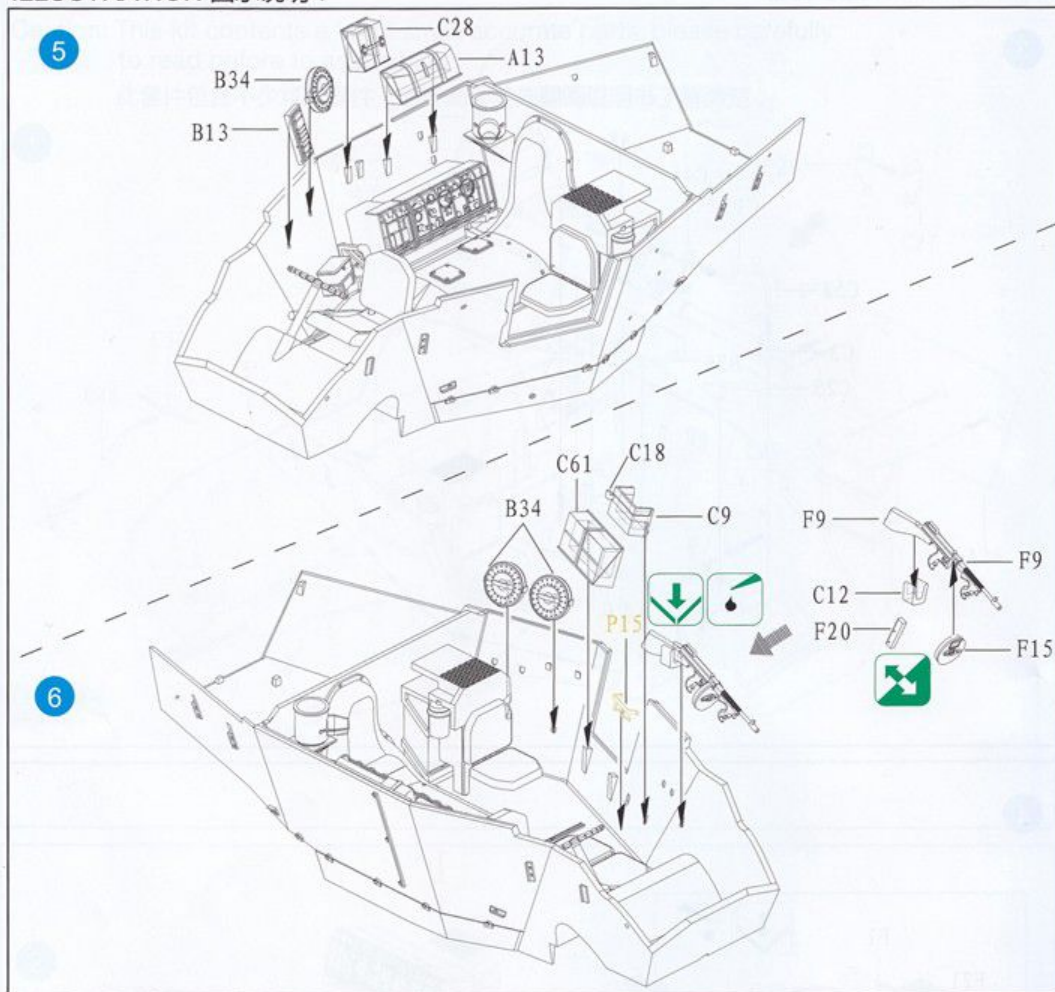

ILLUSTRATION 图示说明：

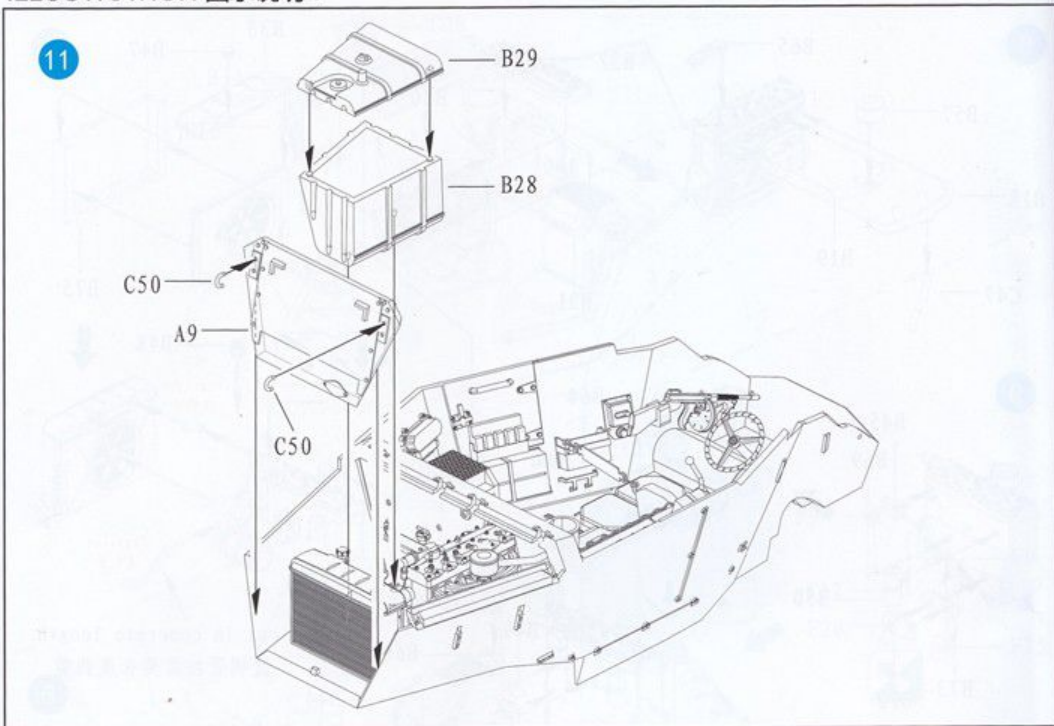

ILLUSTRATION 图示说明：

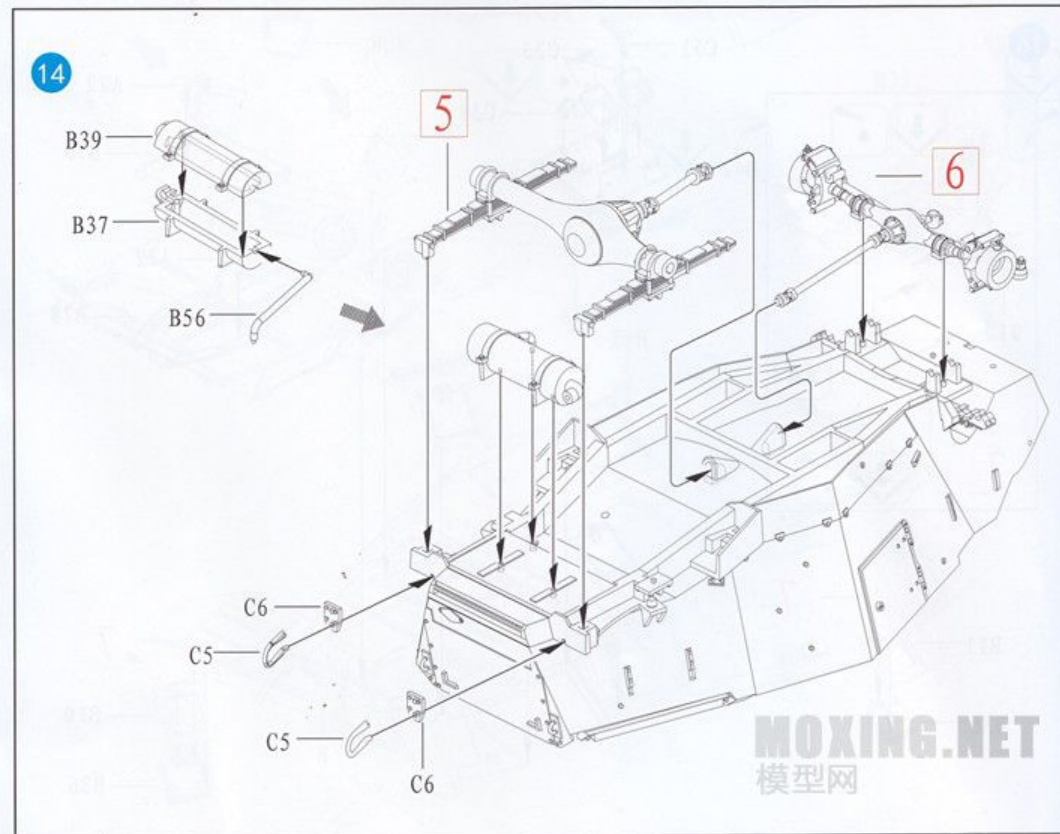
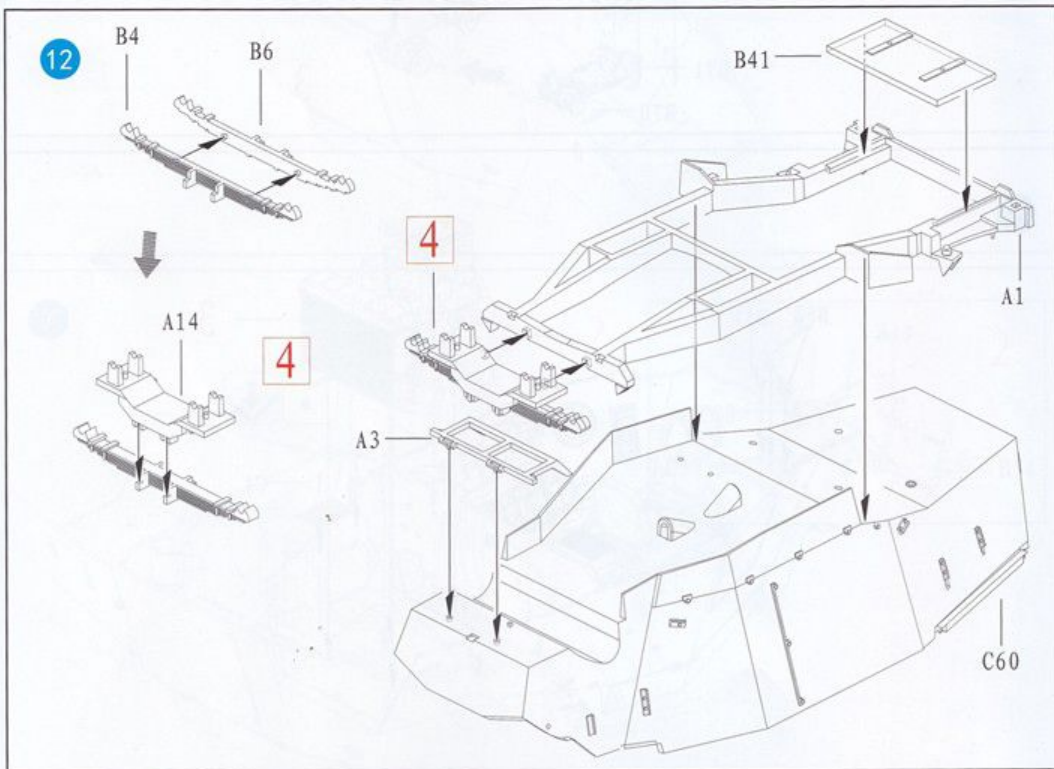
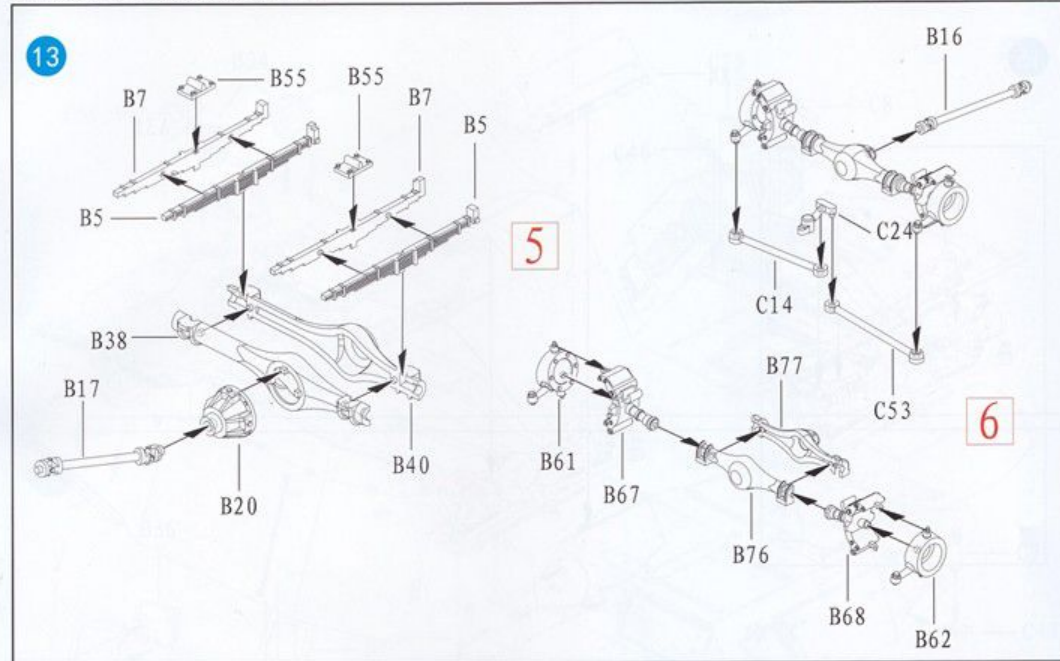

ILLUSTRATION 图示说明：

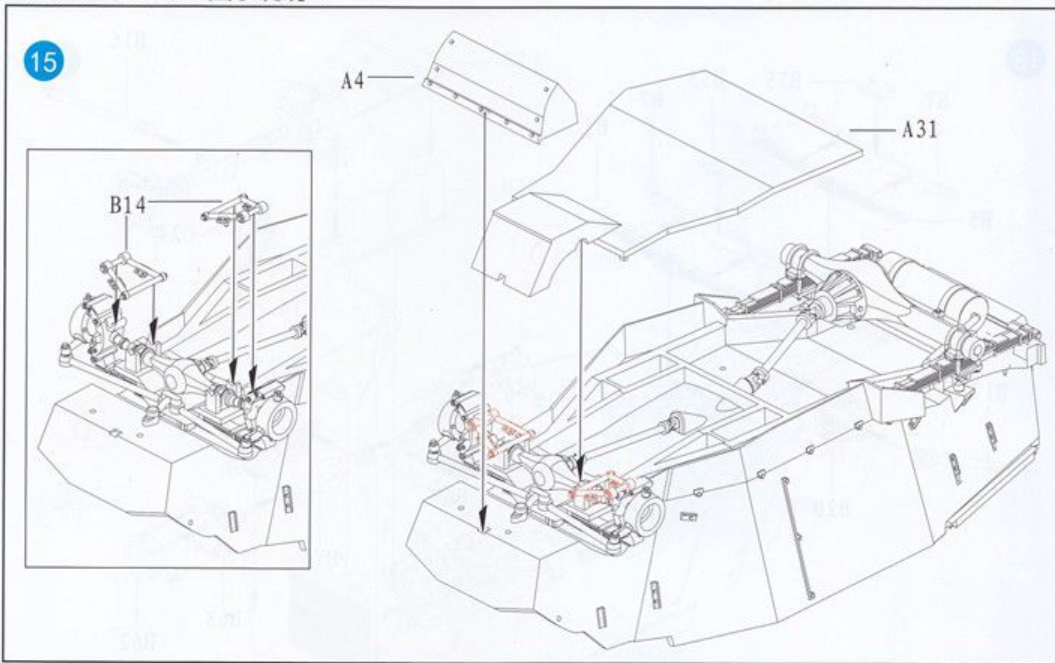
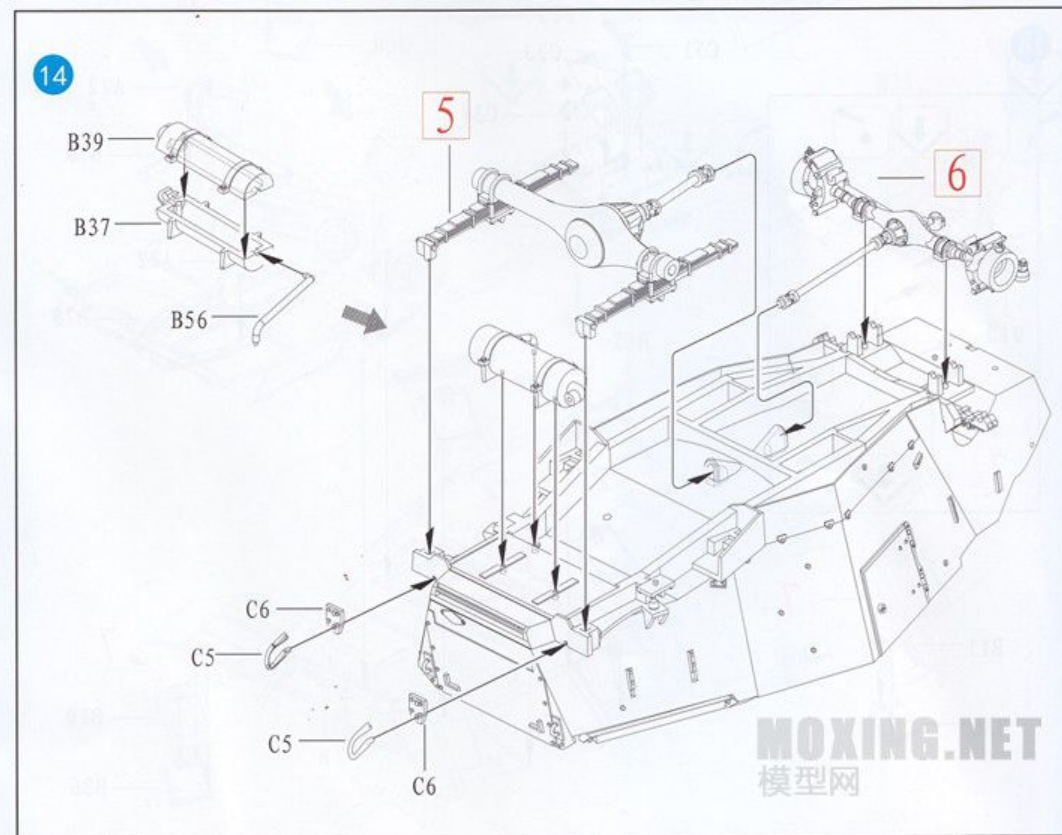
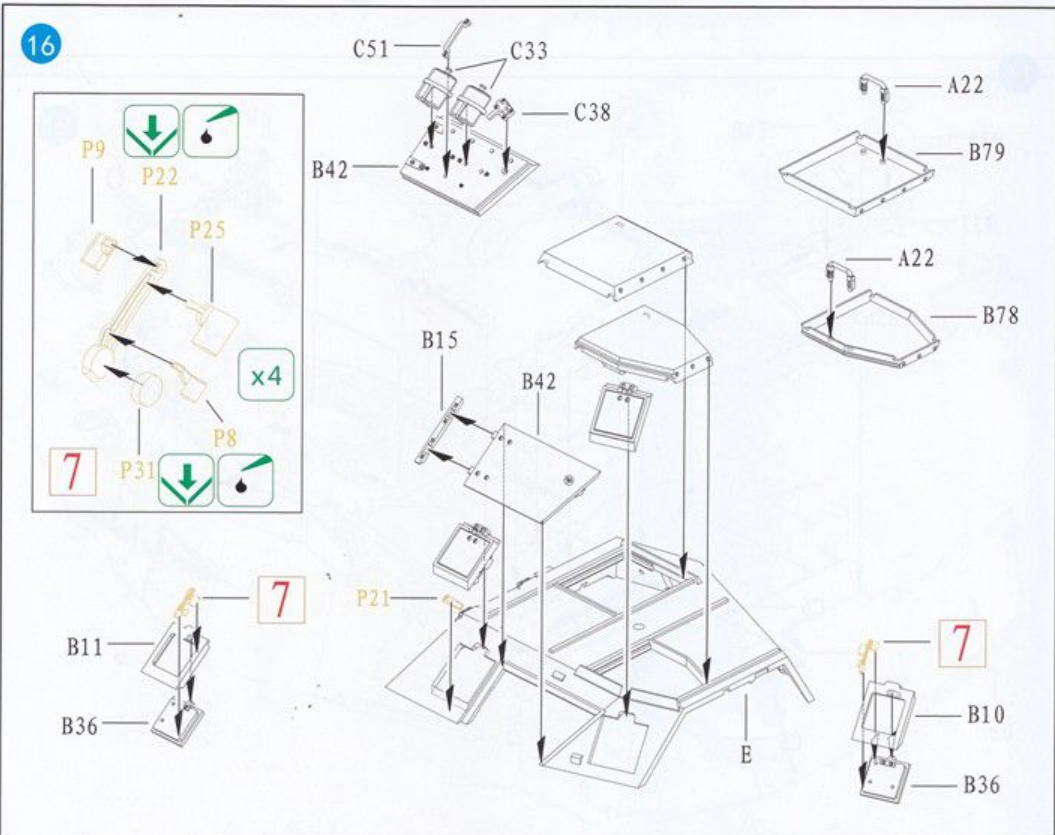
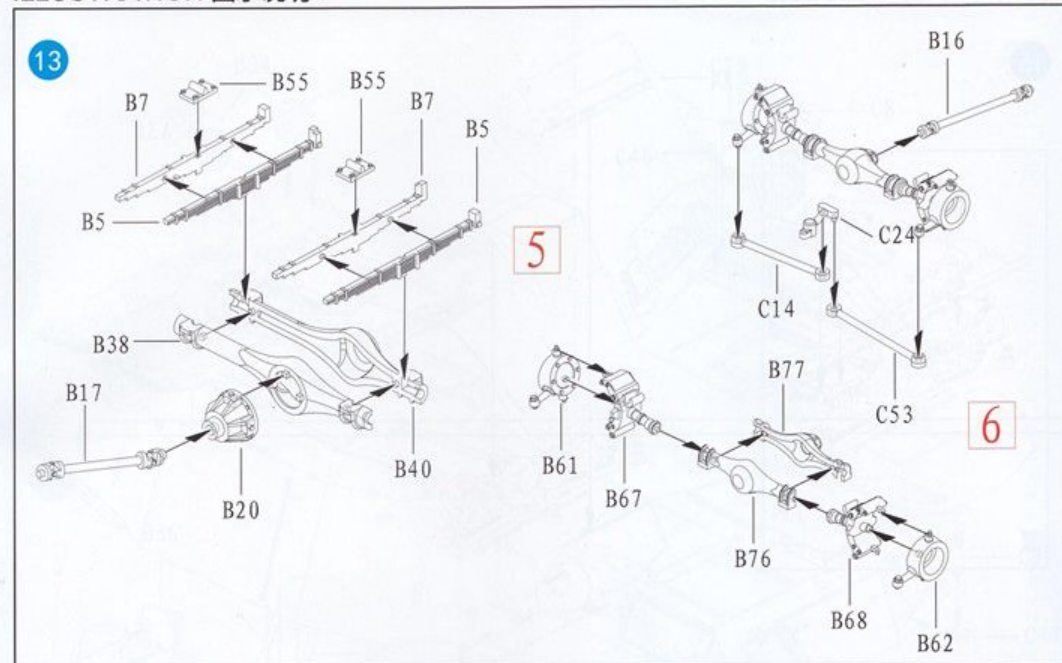
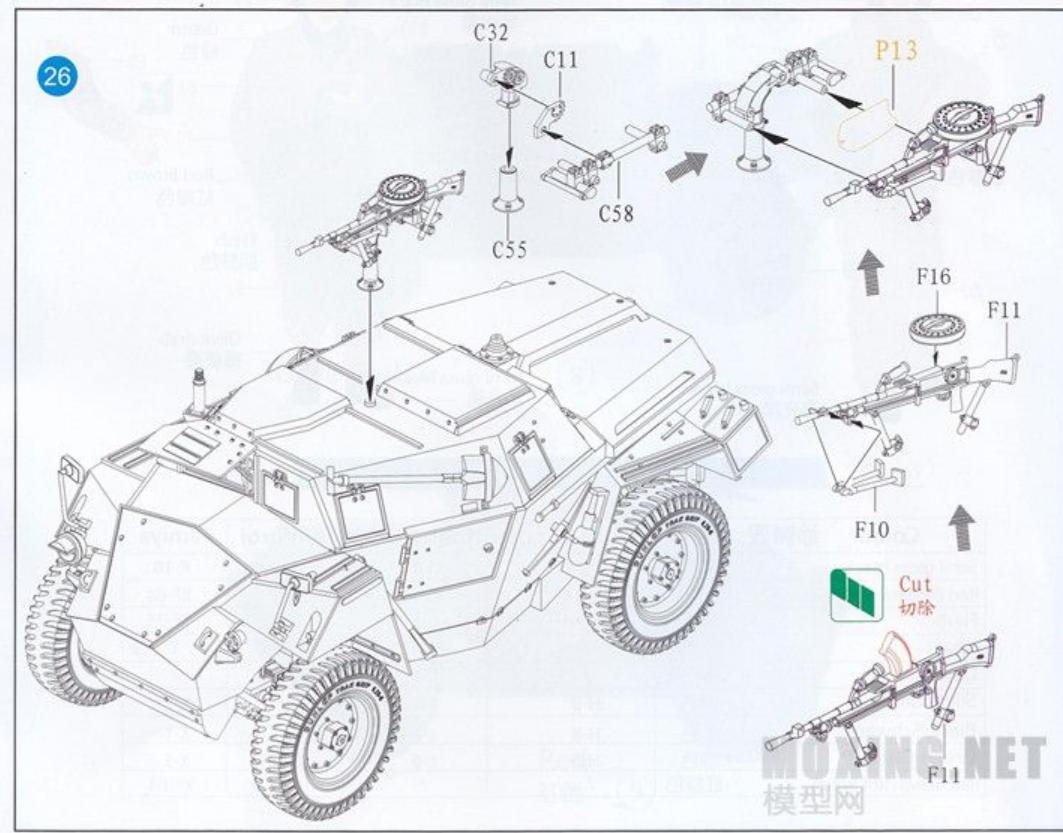
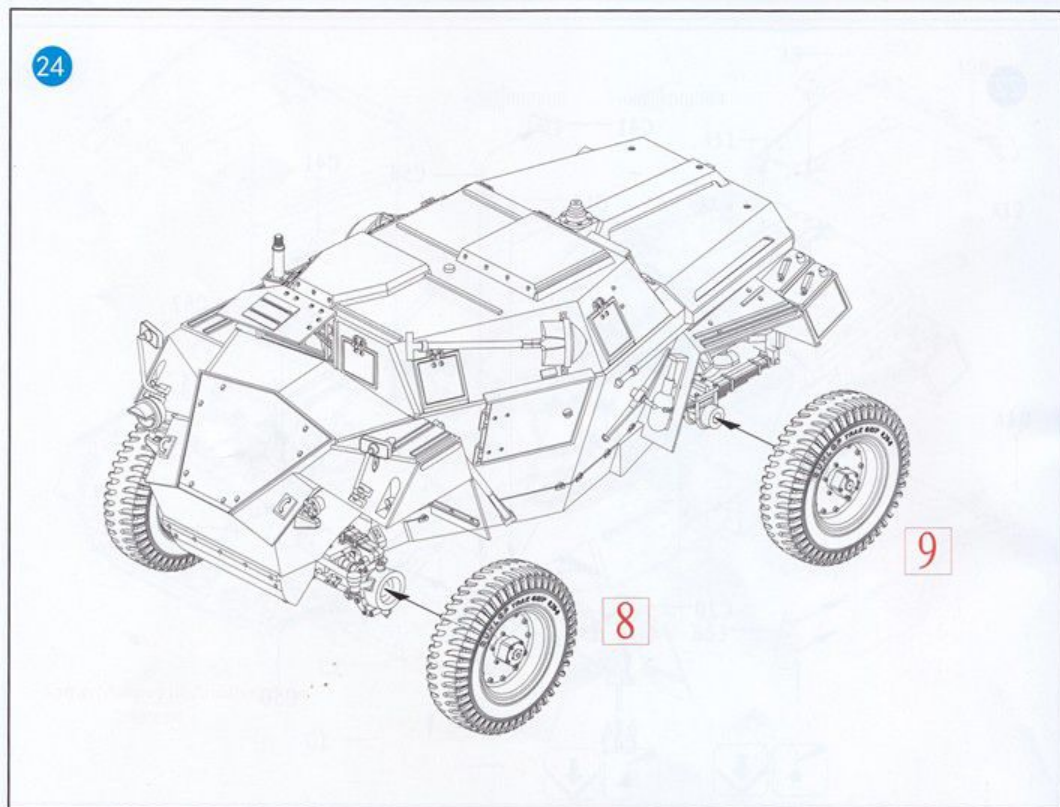
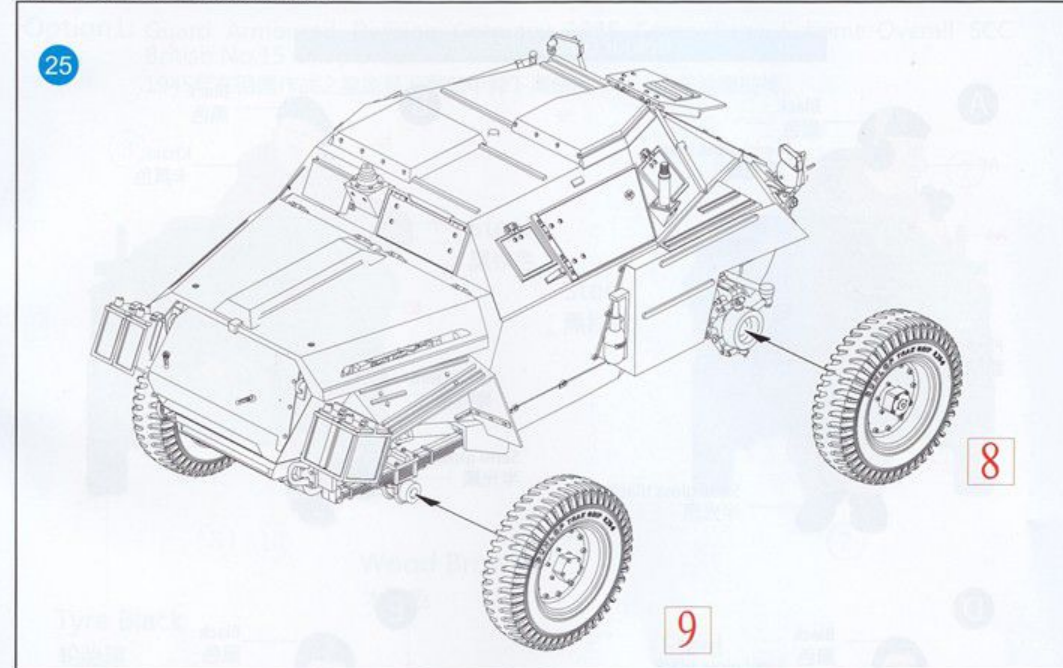
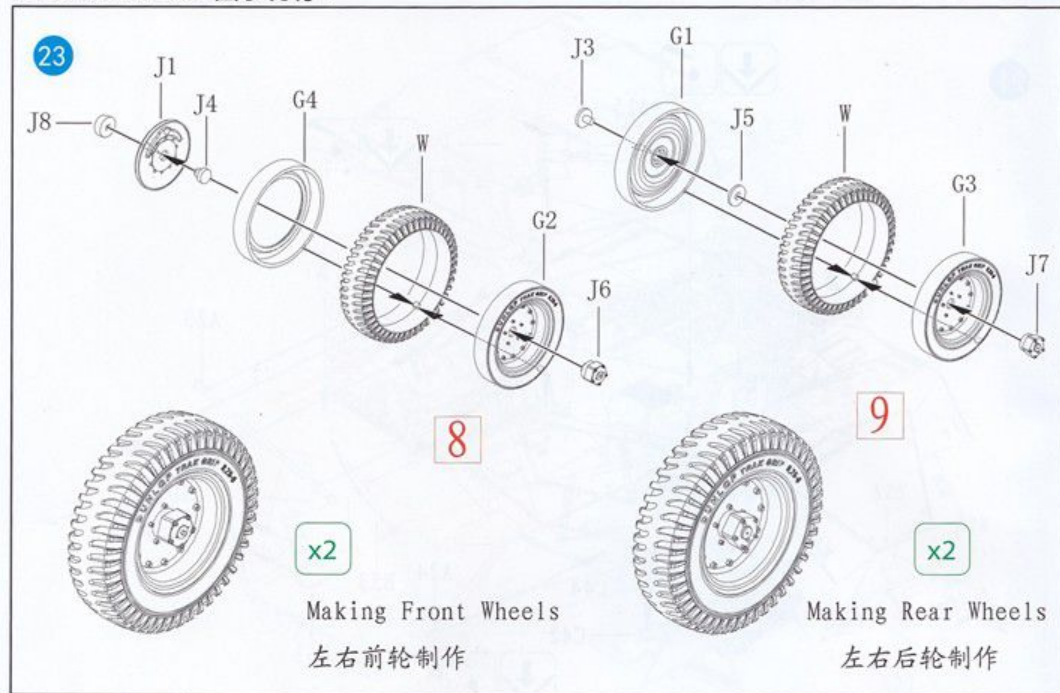

ILLUSTRATION 图示说明：





Colour Guide 涂装指示 :



color suggestion 涂装指引 :

Colour	涂料表	Gunze Sangyo	Hobby Color	Humbrol	Tamiya
Semi gloss black	半光黑	/	C-92	/	X-18
Red Brown Rot Braun	红褐色	H-47	C-41	160	XF-64
Flesh	肌肤色	H-44	C-51	61	XF-15
Khaki	卡其色	/	C-159	/	/
Olive drab	橄榄褐	/	C-163	/	/
Silver Silber	银色	H-8	J-8	11	X-11
Black Schwarz	黑色	H-8	c-2	21	X-1
Green Grün	绿色	H-6	c-6	3	X-5
Red brown Rot Braun	红棕色	/	/	/	XF-64

Option1: Guard Armoured Division Germany 1945 Camouflage Scheme-Overall SCC British No.15 Olive Drab.

1945年在德国作战之皇家禁卫军装甲师下属使用车辆, 全车涂橄榄褐。

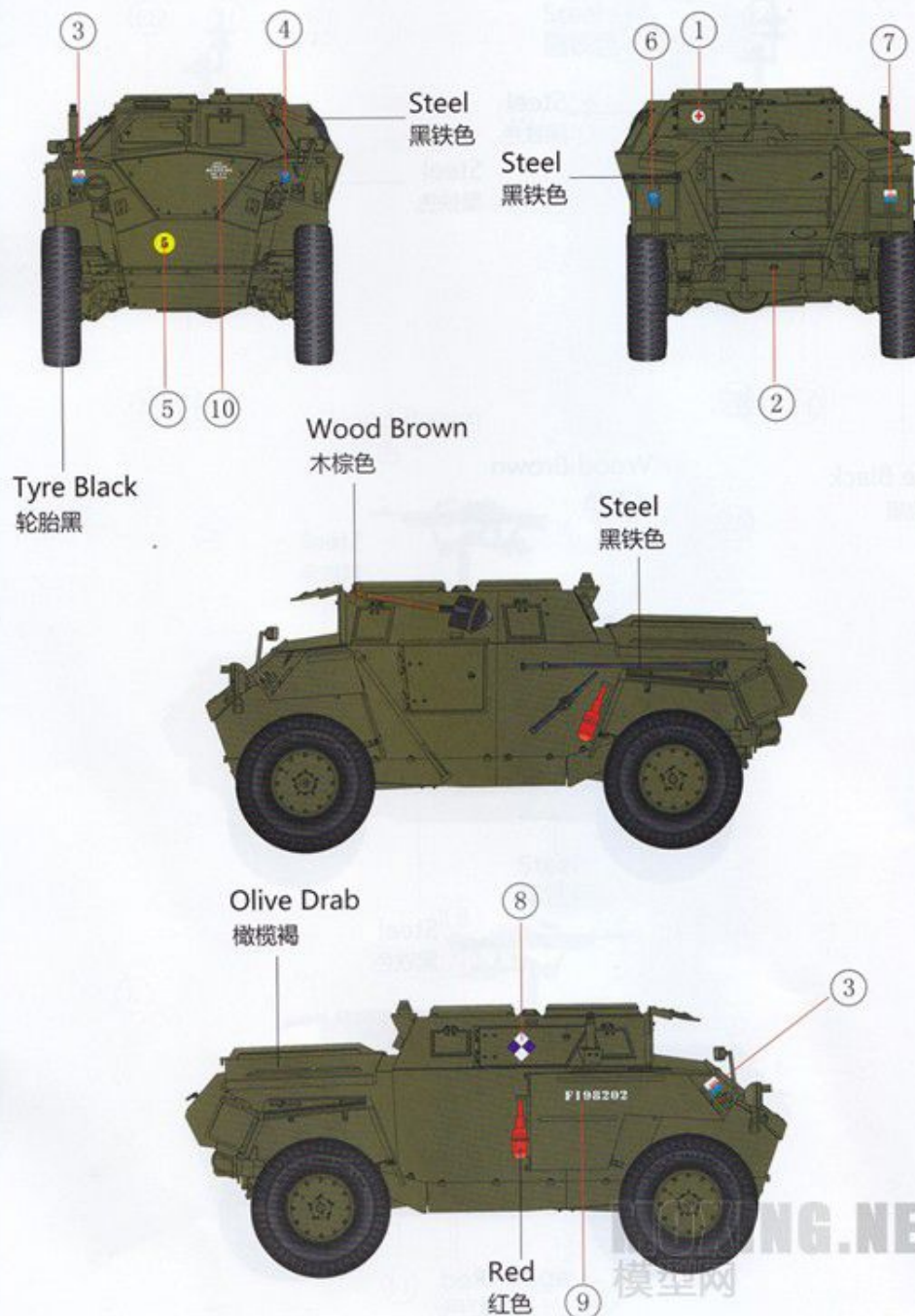

Option2: HSC of AFV Driving & Maintenance School,Lulworth 1943 Camouflage Scheme-Overall Colour SCC2 Brown.

1943年英格兰诺和夫装甲驾驶学校训练用车辆，全车涂咖啡色。

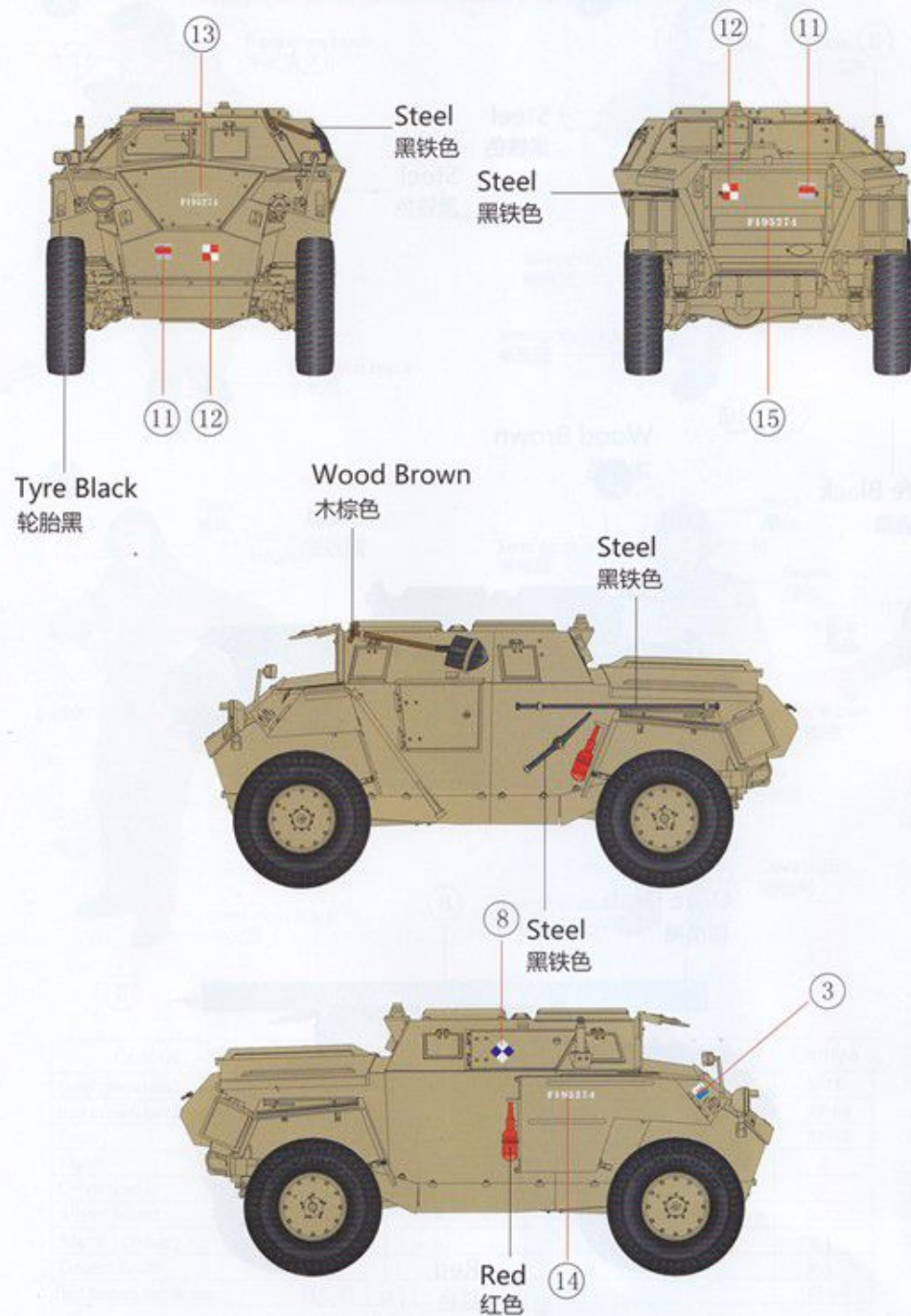

Option3: RHQ-3RTR, 29th Armoured Brigade, 11th Armoured Division Germany 1945. Camouflage Scheme-Overall British SCC15 Olive Drab.

1945年在德国作战之英国第11装甲师第29装甲旅下属车辆，全车涂英式橄榄褐15号。

