

1

A/C 3: Bf109 G6 of an unidentified unit, Spring of 1943, possibly a training unit. Very rare camouflage of RLM82/83/76 with RLM 76 splotches over Greens. No cowling or wing tip markings. Spinner RLM 70. Short antennae mast. Upper surfaces camouflage is conjectural. Notice unusual position of lower wing crosses. A truly rare bird!

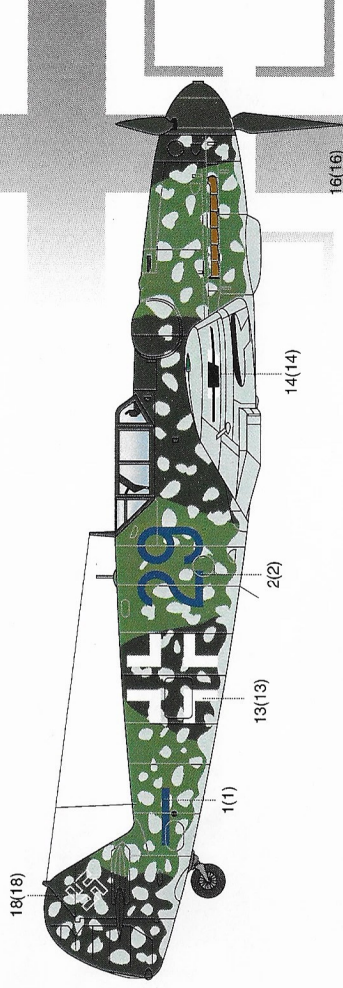

2

Untoffz. Gerog Amon, who finished the war with 9 kills, served with 7/JG53. Depicted in June, 1943, his Bf109G-6 Trop wears RLM74 Dunkelgrau, RLM 75 Grauviolet and RLM74/75 mottling over RLM76 Lichtrau. Note the RLM04 Gelb cowl chin and RLM70 & White prop spinner. White fuselage band and lower wing tips. Notice wide band covers more than just one fuselage section.

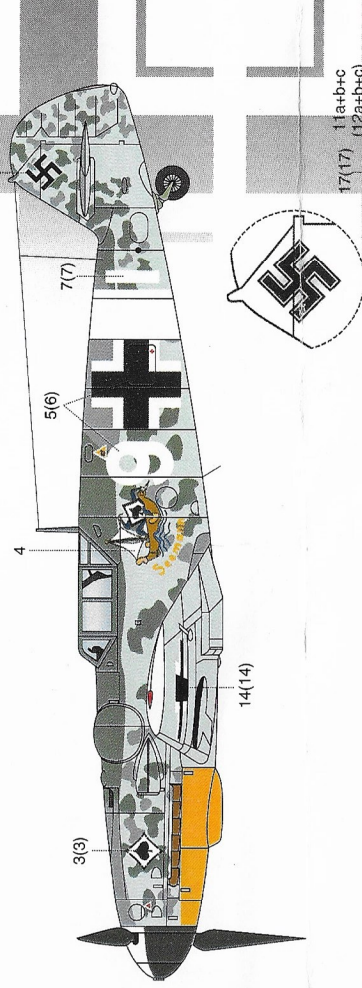

3

Bf109G-6 flown by Hauptmann Anton Hackl, III JG/II, Germany, early 1944. Standard camouflage of RLM 74/75/76 with Yellow rear fuselage band and lower cowling. White vertical fin and rudder. Notice paint is chipping or wearing out from between the swastikas arms (see inset). Spinner seems to be 1/2 or 1/3 White and the rest RLM 70. 20 mm underwing guns were carried in this A/C. A very successful fighter pilot, Hackl shot down among many, 25 US Heavies (4 engines) and survived the war, dying in 1984.

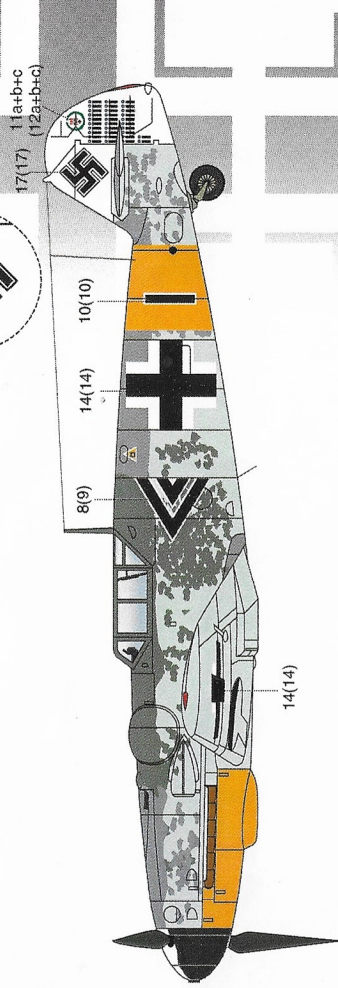

BF-109G GENERAL STENCIL PLACEMENT & CAMOUFLAGE PATTERN

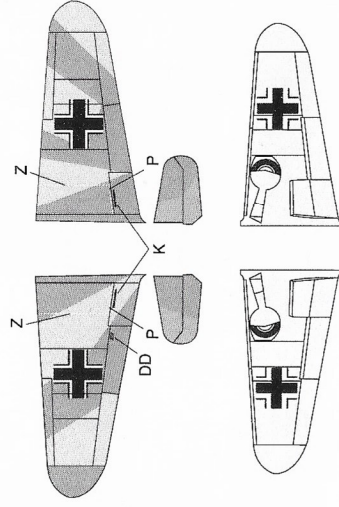
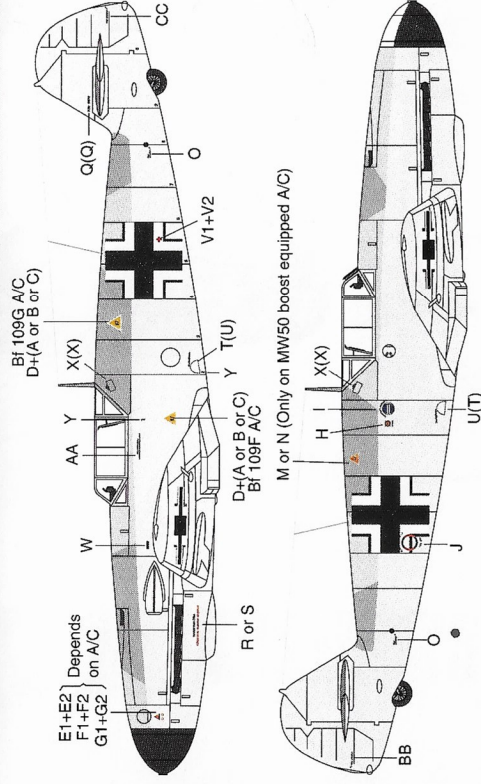

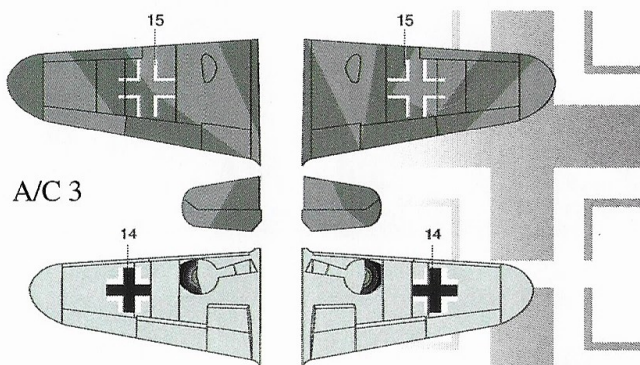
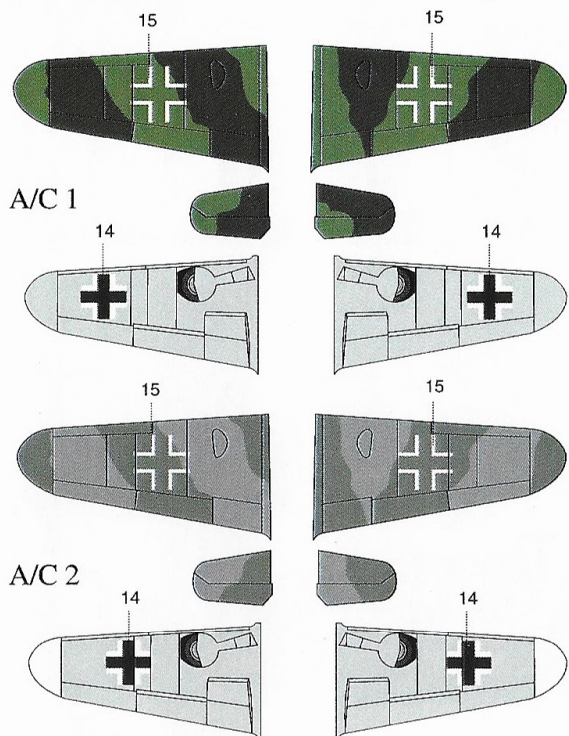

References:

1. Shigeru Nohara. Luftwaffe Aces in WWII.
2. Shigeru Nohara., M. Shiwaku. Aero Detail 5: Messerschmitt Bf 109. Dai Nippon Kaiga Co., Ltd, 1992.
3. Sundin C., C. Bergstr m. Luftwaffe Fighter Aircraft in Profile. Schiffer Publishing Ltd, 1997.
4. Keskinen K.,K. Stenman, K. Niska. Suomen Ilmavoimien Historia: Messerschmitt Bf 109G. Forssan Kirjapaino OY Forssa, 1976.
5. Shigeru Nohara. Messerschmitt Bf 109F "Friedrich".
6. Shigeru Nohara. Messerschmitt Bf 109G/K Augsburg Eagle.

Recommended Kits:

Hasegawa BF 109 G6 Family.

Decaling: Apply decals only to a glossy surface.

1. With a sharp scissors or knife, carefully cut item to be used, being careful of not cutting off the clear film around it or that belonging to an adjacent item.
2. Submerge in clean tap water for over 10 seconds and lay over an absorbent paper towel. Decal will slide freely in about 20 seconds. Do not leave decal on water bowl over ten seconds, or adhesive quality will suffer.
3. With a clean brush, apply a setting solution to the area where the decal will finally lay. (Micro, Super or Aero Set will do). With a clean pointed brush slide the decal on to the final area. Allow the setting solution to dry for about 3-5 minutes.
4. With another clean brush, apply a solvent solution over the decal (Micro, Super or Aero Sol will do). Do this if possible in one stroke since your decal will soften up and wrinkle immediately. This is an important step in the process, whatever you do **DO NOT TOUCH THE DECAL**, after this process until it is totally dry, preferably overnight.
5. When thoroughly dry, rinse your model with tap water and mild soap to wash of excess glue.
6. Finish your model with the desired final coat (gloss, flat, or semi-gloss).



**EAGLE STRIKE
Productions**

12982 SW 132nd Ave. Miami, FL. 33186
U.S.A.
Ph: (786) 293-6859, Fax: (786) 293-9286.

32038