

**Notes on Construction**

Step 1. Drive Sprockets – Use part V19

Step 4. Use parts T5, MA10, MA11

Step 5. Use U31 and U30

Step 6. Don't use part X17

Do not U19 – Fill hole

Step 8. Don't use W18 – make up a 4mm x 2mm

patch from .25 styrene

Don't use W17 – sand hull smooth at that location

Do not use W7

Use resin engine deck in place of W8 and W14

Install V32

Step 9. Do not use MA49

AIM kit Step 10. Use cupola instructions (left)

Step 14. Use W13 and W12 in place of W15 and W16

Use Q11 instead of Q8

Do not use Q5

Use Q6 and Q7, Do not use Q9 and Q10

Use N8, Do not use X31

Step 16. Do not use X6

AIM Step 14. Add part Q2 (below)

AIM Step 17. Assemble air con unit  
(right)

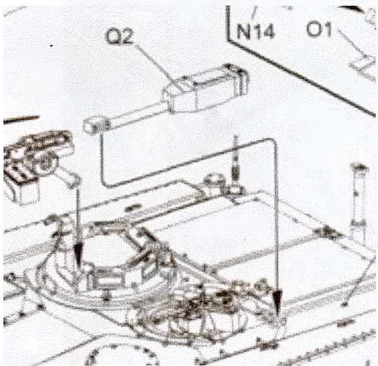
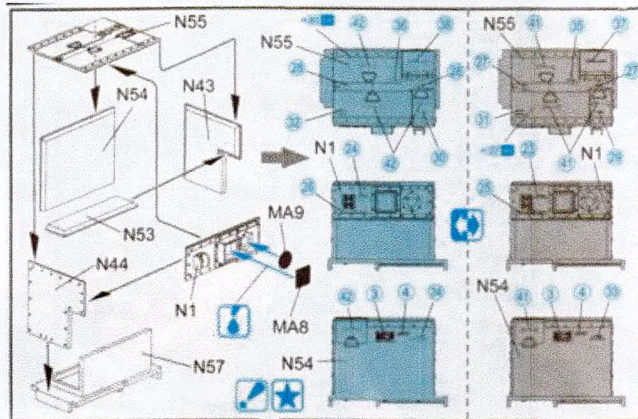
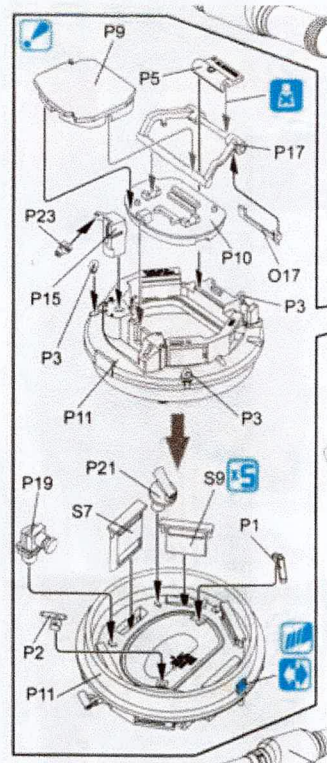

**BLACK OPS MODELS**

Version 1.0

# 1/35 Australian M1A1 AIM SA Abrams

## Conversion Kit for Dragon M1A2 SEP No.3536



## Kit Instructions

- Please read all instructions before starting assembly.
- Wash all parts in warm soapy water before assembly.
- Use cyanoacrylate (CA) or epoxy glue for assembling resin parts.
- Use only paints suitable for resin model kits.

## Safety Warning

- All parts are a choking hazard, therefore keep parts and bags away from children.
- Wear protective eye ware when cutting parts and beware of sharp edges.
- Do not breathe in the dust from resin, wear a protective mask when sanding, gluing and painting.
- Use paints and glue in a well ventilated area.

## PARTS

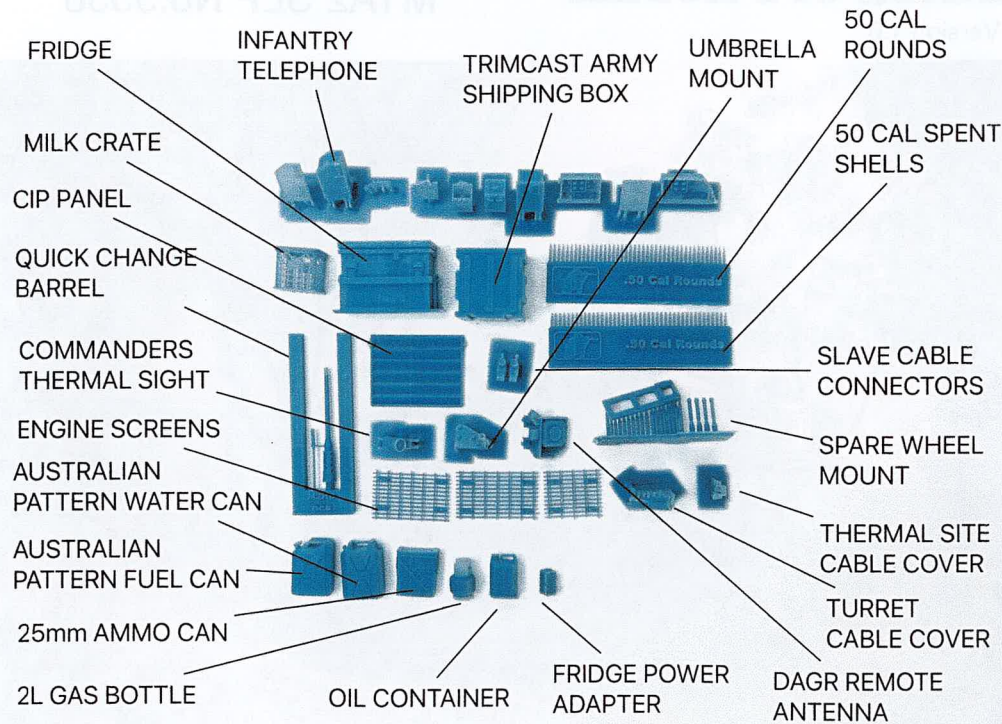

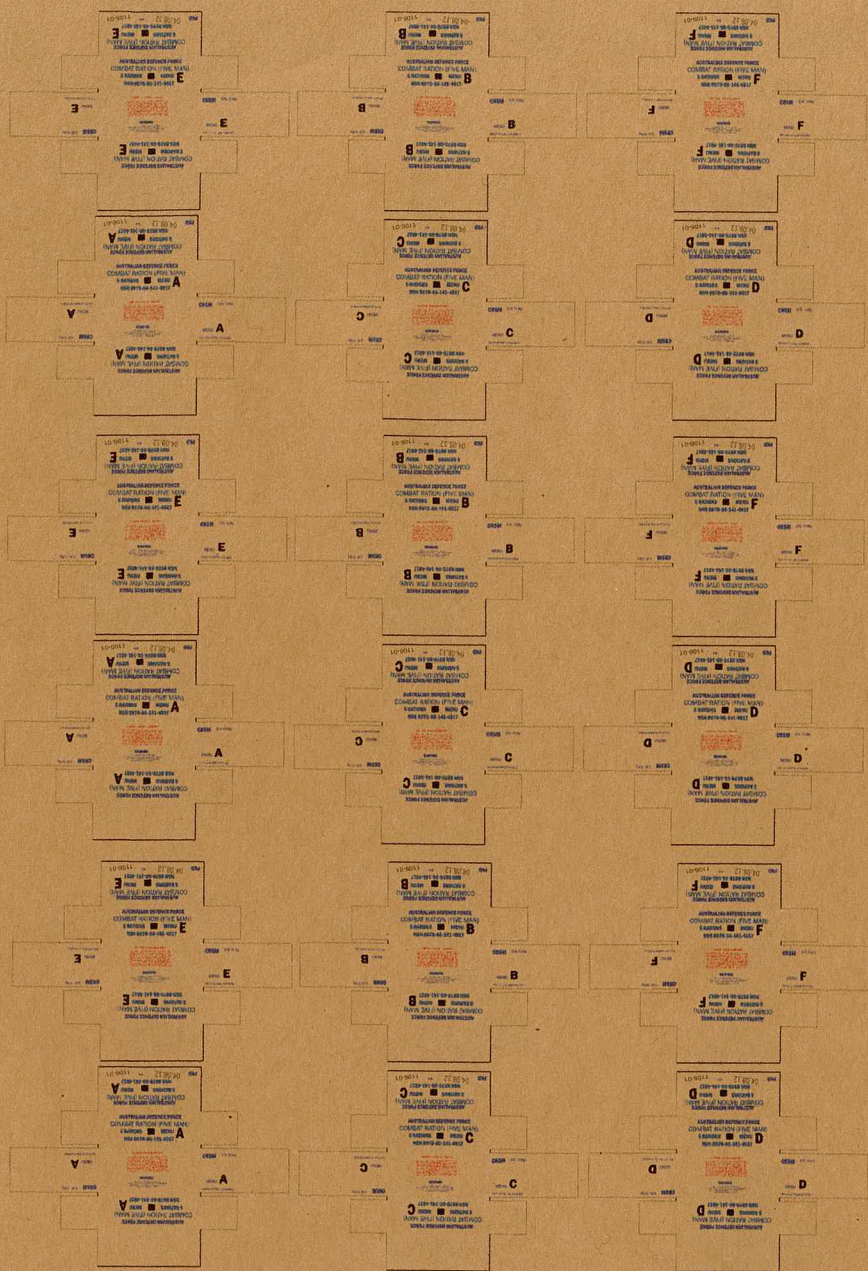

AUSTRALIAN ARMY CR5M 1/35



BLACK OPS MODELS