

The right color for your F-16XL!

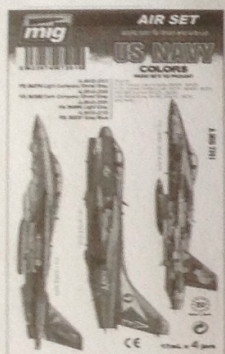

AMO-7201 US NAVY COLORS



AMO-7202 USAF COLORS Grey Modern jets



AMO-7200 IAF Desert color



1/48 F-16XL Experimental Fighter



F-16XL

F-16XL EXPERIMENTAL FIGHTER

The F-16XL is a derivative of the F-16, with a cranked-arrow delta wing. It was originally conceived as a technology demonstrator, later entered in the United States Air Force's Enhanced Tactical Fighter (ETF) competition but lost to the F-15E. Several years after the prototypes were shelved, they were turned over to NASA for additional aeronautical research.

The F-16XL could carry twice the ordnance of the F-16 and deliver it 40% farther. The enlarged wing allowed a total of 27 hardpoints.

In 2007, NASA request a study into the feasibility and cost of returning F-16XL #1 to flight status and upgrading it with many of the improvements found in the USAF's F-16 Block 40. This was studied while F-16XL #1 was taxi tested at Dryden and given systems checks. However, both F-16XLs were retired in 2009 and stored at Edwards AFB.

CAUTION

- *Read carefully and fully understand the instructions before commencing assembly.
- *Keep out of reach of children. Children must not be allowed to put any parts in their mouths, or pull plastic bag over their heads.
- *When using adhesives and paints, please make sure not to use them in closed room or near the fire.
- *When assembling this kit, tools including knives are used. Extra care should be taken to avoid injury.

WARNING: CONTAIN SMALL PARTS NOT FOR CHILDREN UNDER 14 YEARS OF AGE.

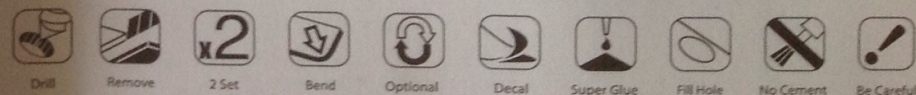

TOOLS RECOMMENDED

Cement

Side Cutter

Modeling Knife

Tweezers

1/48 F-16XL Experimental Fighter

SKUNK MODELS WORKSHOP

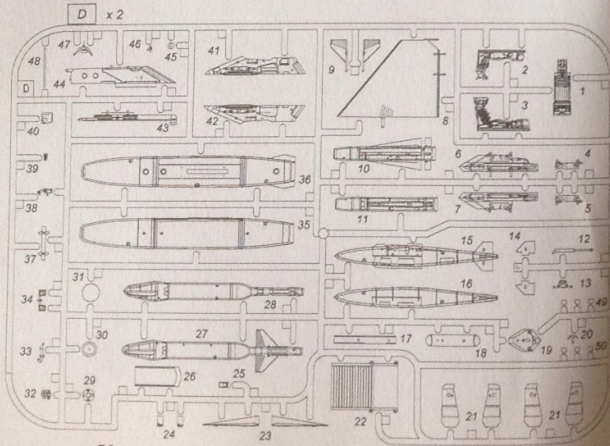
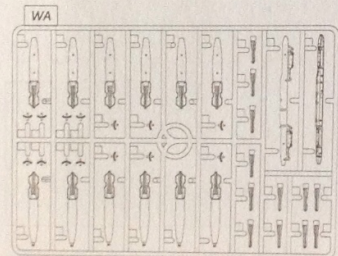
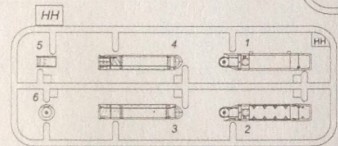
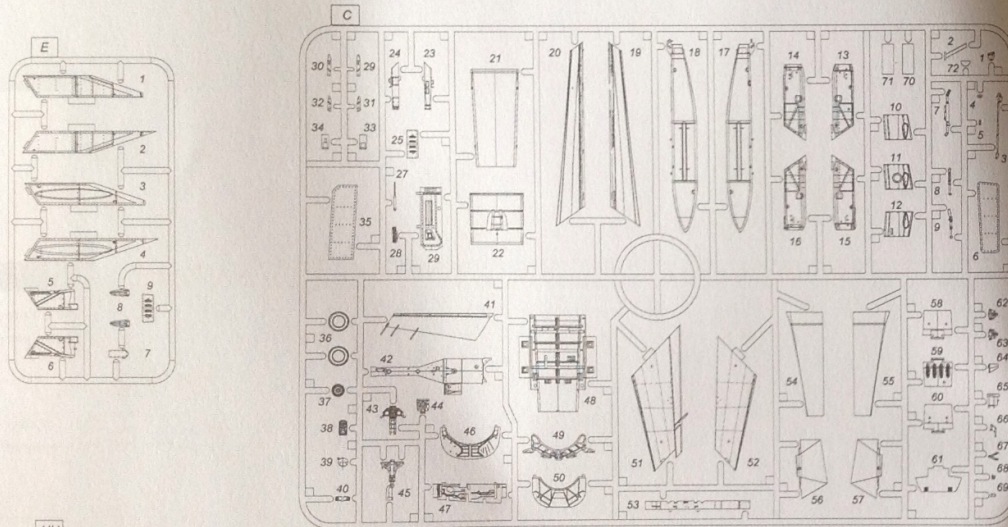
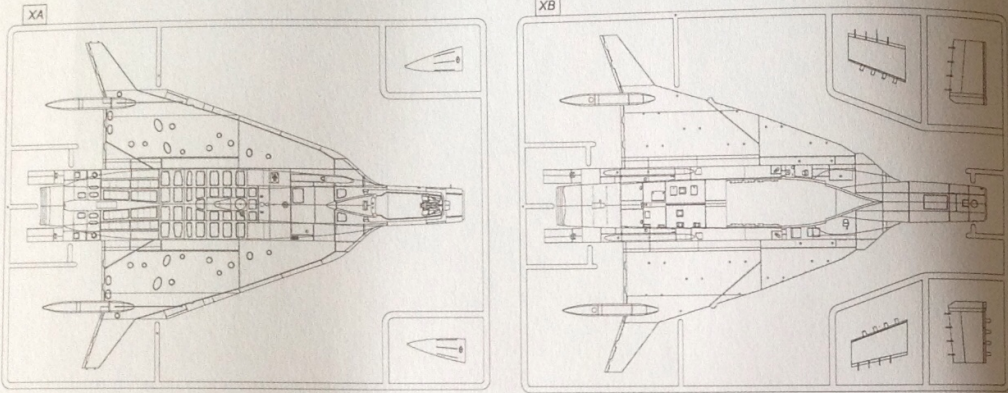

1/48 F-16XL Experimental Fighter

SKUNK MODELS WORKSHOP

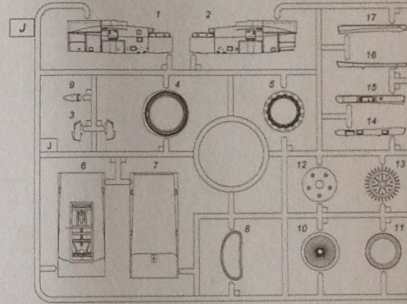
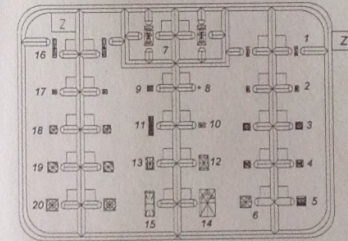
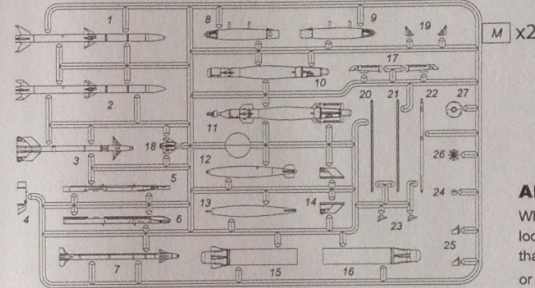
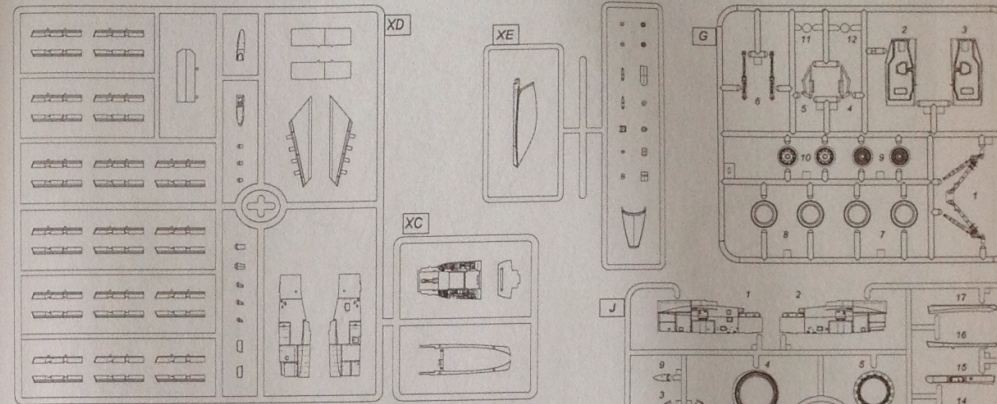

AFTERMARKET SERVICES CARD

When requesting replacement parts, please take or send this form to your local dealer so that the parts required can be correctly identified. Please note that specifications and availability are subject to change without notice, or visit <http://www.kineticmodel.com> for latest information.

For more information, please contact services@kineticmodel.com

Parts Code	Item	SW48026
00-100-014	Dx2	F-16 Parts - 370 Gal Fuel Tank (Parts D)
00-100-015	E	F-16a/b Vertical Fin Parts (Mt-116-015) Parts E
00-100-017	G	Block 15 Landing Gear - Parts G
00-100-020	J	Nsi Intake - Parts J
00-100-021	Mx2	Weapon Set (Aim-9x,9m,120b/c,gbu-12) Parts M
00-100-022	Z	Clear Parts For F-16 - Parts Z
00-100-031	Hh	Aaq-13/aaq-14 Parts Hh
00-143-001	WAx2	1/48 Mk83 Snakeye Bomb W/ Mer
00-148-001	XB	1/48 F-16xl Bottom Parts
00-148-002	XA	1/48 F-16xl#1 Top (Single Seat)
00-148-003	XC	1/48 F-16xl Comment Parts
00-148-004	XD	1/48 F-16xl#1 Single Seat Parts
00-148-006	XE	1/48 F-16xl Clear Parts/canopy
01-100-001		F-16 Stencil Decal
01-148-48026		1/48 F-16xl #1 Decal
03-148-48026		1/48 F-16xl #1 Manual

PAINT INDEX

Color	Ammo Mig	Humbrol Enamel/acrylic	Italen Acrylic Paint	Tamiya Enamel/acrylic	GSI Creos Mr. Color	Vallejo Model Color
FLAT BLACK	46	33	4768AP	XF-18	33	950
FLAT WHITE	50	34	4796AP	X-2	-	951
CLEAR RED	93	1321	-	X-27	47	934
CLEAR GREEN	92	1325	-	X-25	138	-
US Ghost Grey	208	127	-	-	308	-
Gun Metal	45	53	4681AP	X-10	-	863
SATIN BLACK	32	-	-	-	-	-
Light Green Khaki	58	-	-	-	-	-
Medium GunShip Gray (FS36118)	204	-	-	-	-	-
Medium GraY (FS36270)	211	-	-	-	-	-
Red (FS31350)	49	-	-	-	-	-
Insignia Blue (FS35044)	214	-	-	-	-	-
BS 638 (FS36231)	205	-	-	-	-	-
Dark Gray (FS36280)	215	-	-	-	-	-
Gray (FS36307)	216	-	-	-	-	-
Tan (FS30219)	202	-	-	-	-	-
Middleston (FS33531)	200	-	-	-	-	-
Light Gray Green (FS34424)	201	-	-	-	-	-
Light Compass Ghost Gray (FS36375)	203	-	-	-	-	-
Oliver Drab base	926	-	-	-	-	-

1

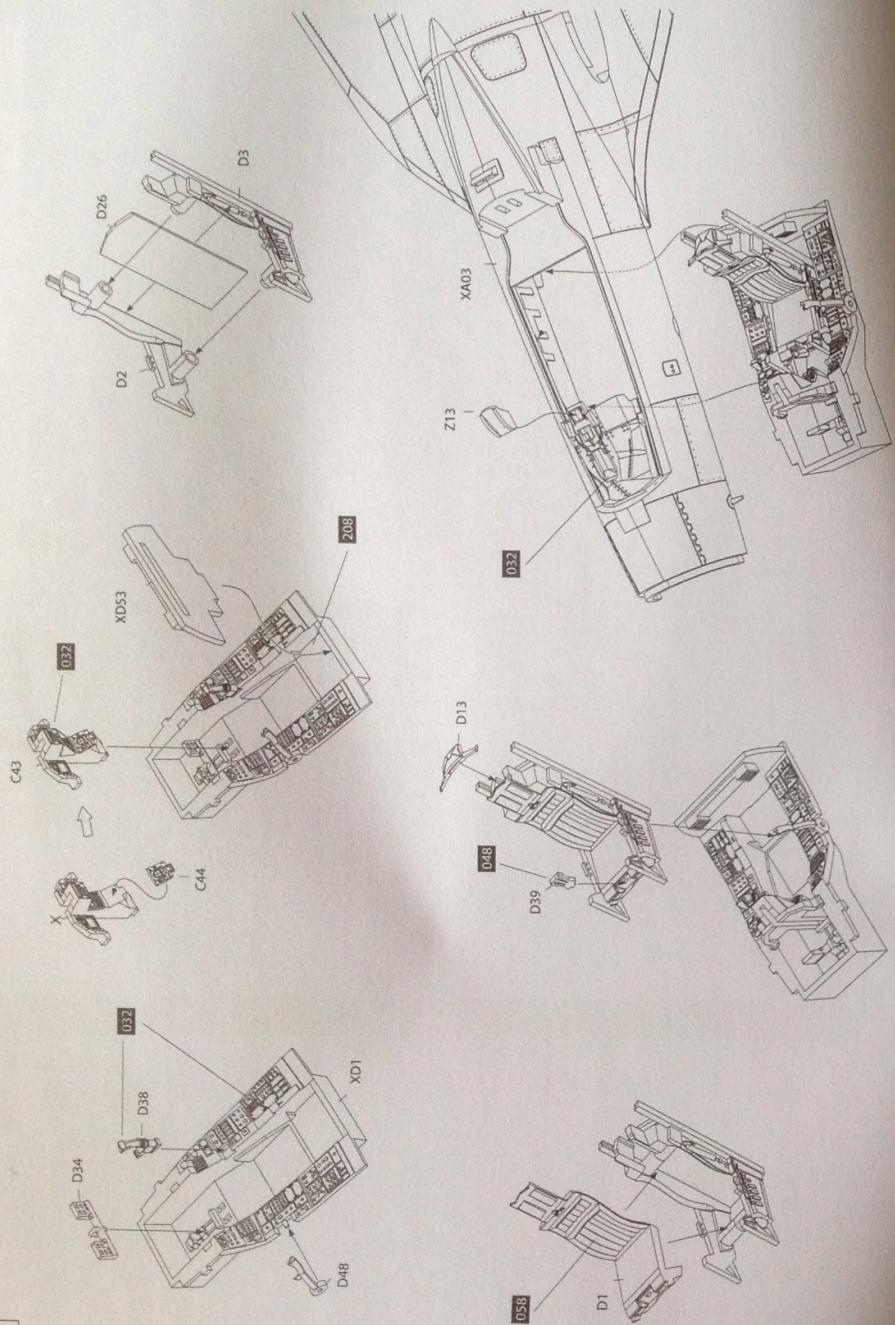

2

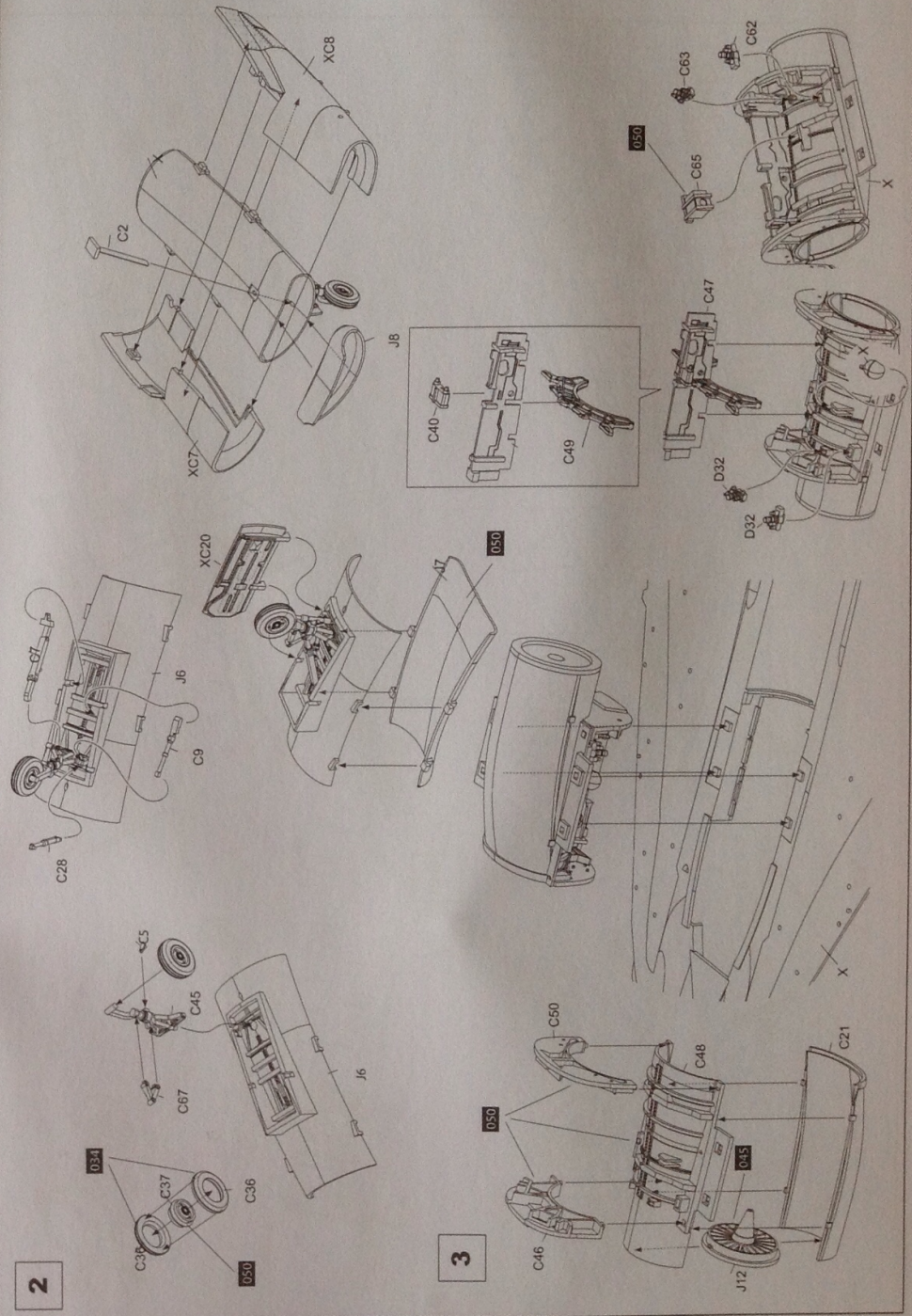

3

4a

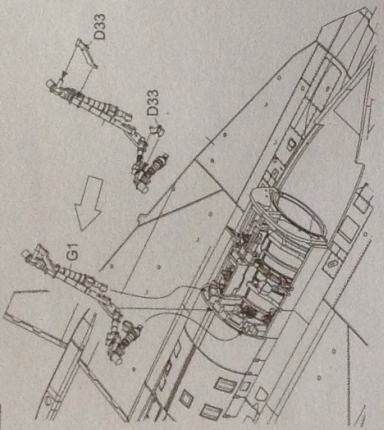

4b

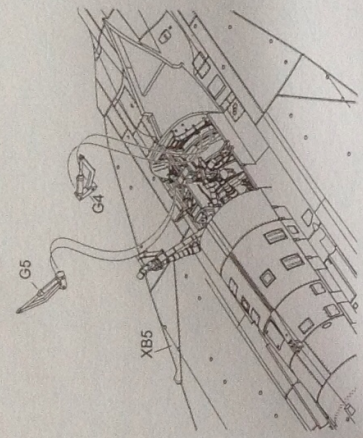

4c

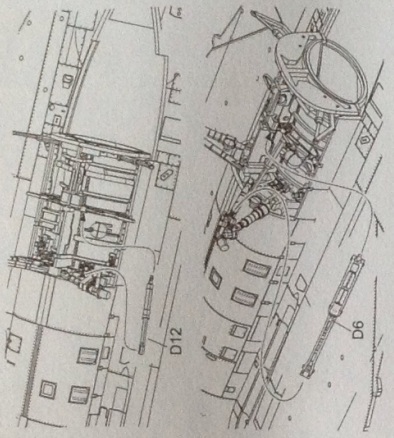

4d

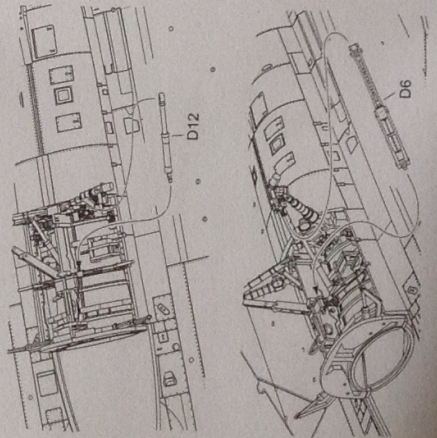

4e

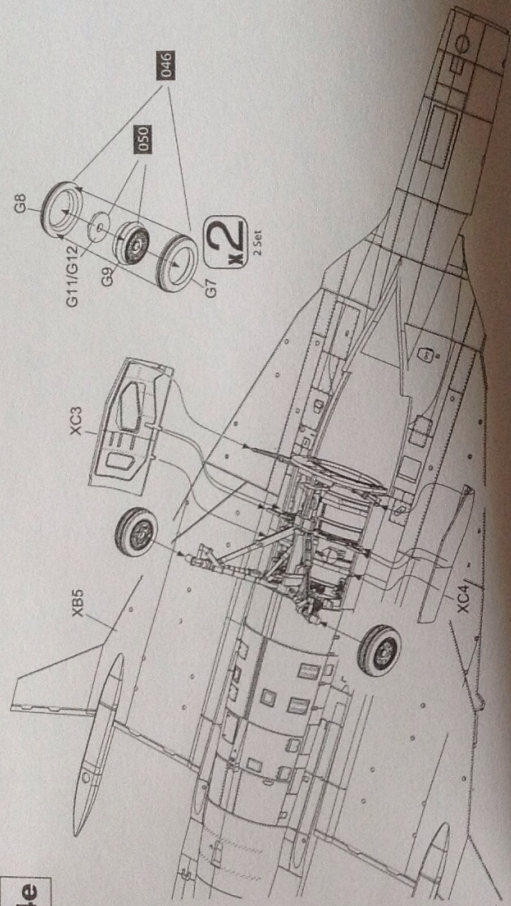

5

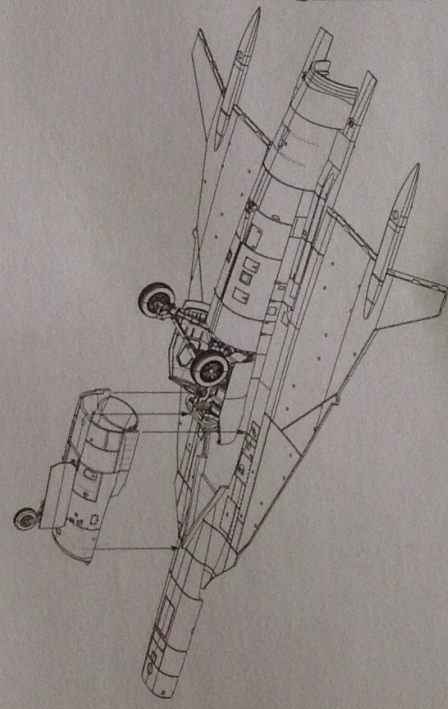

6

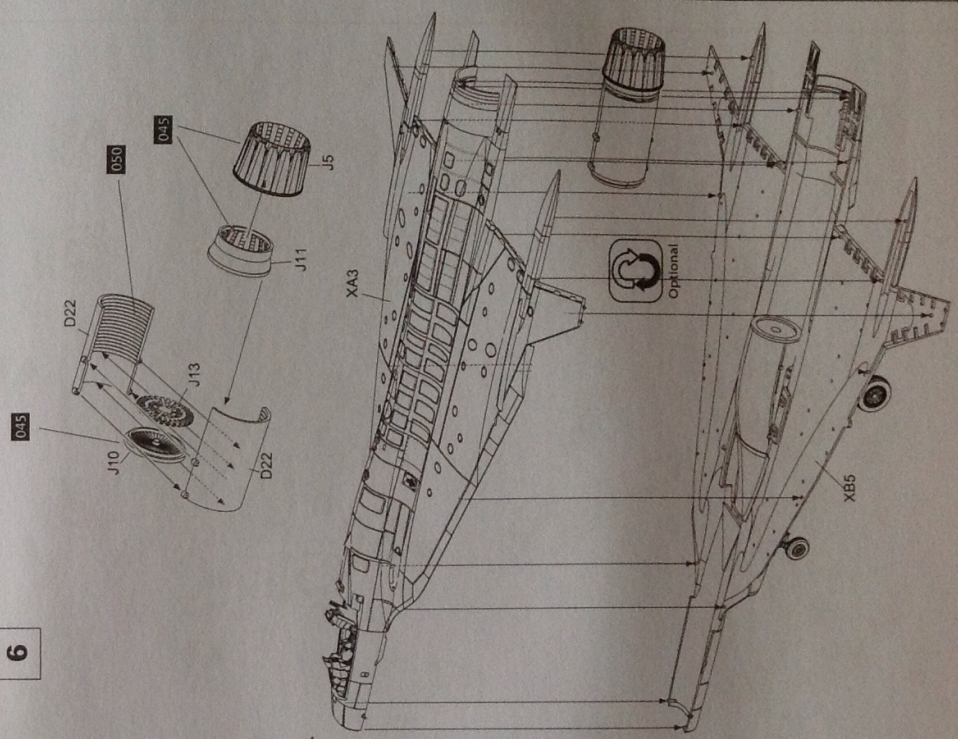

7

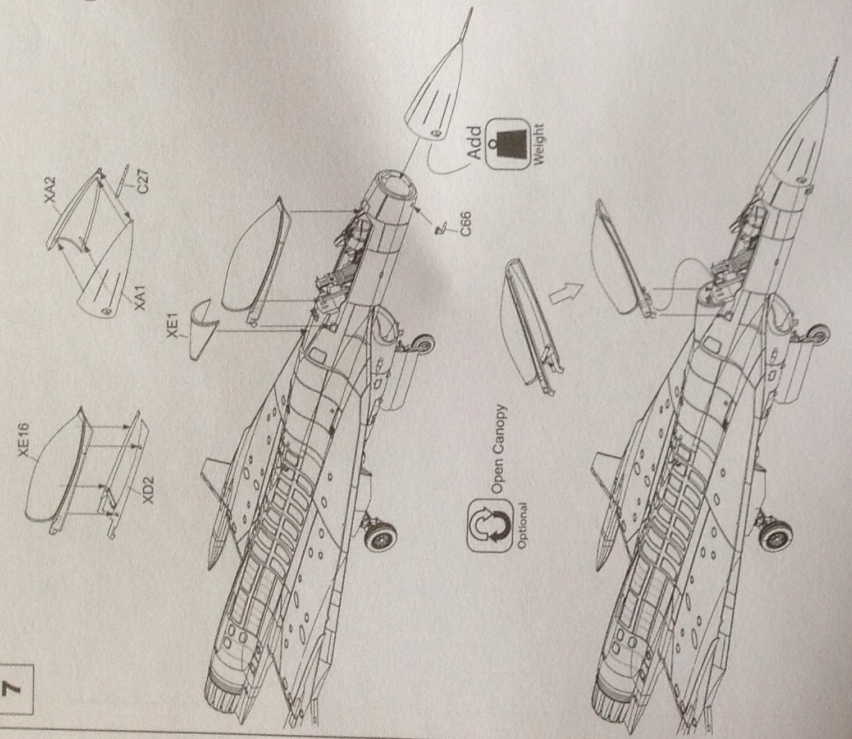

8

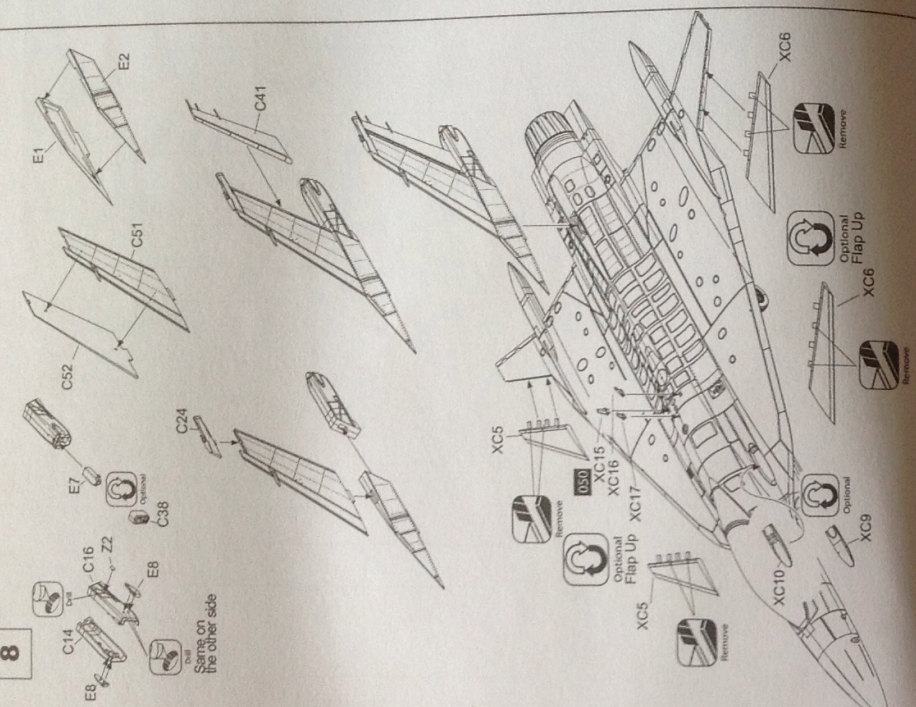

9

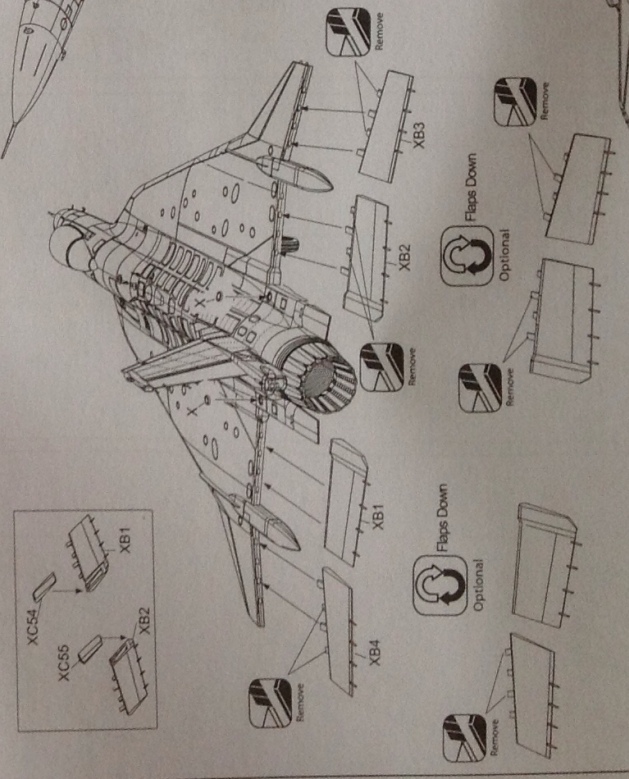

10

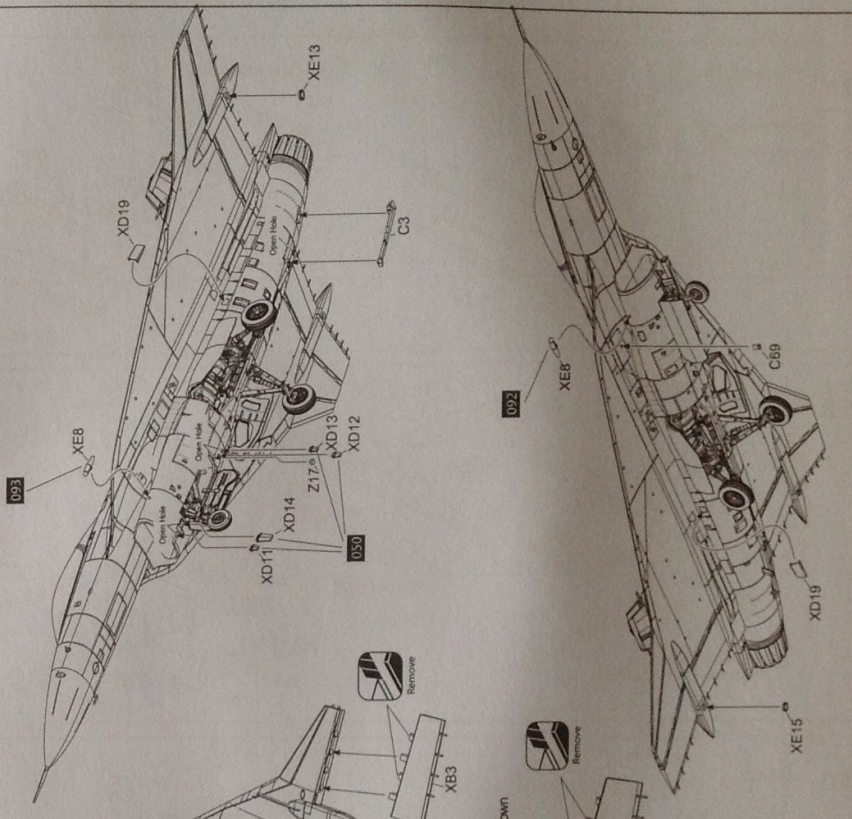

11

370 Gallon Wing Tank

300 Gallon Centenline Tank

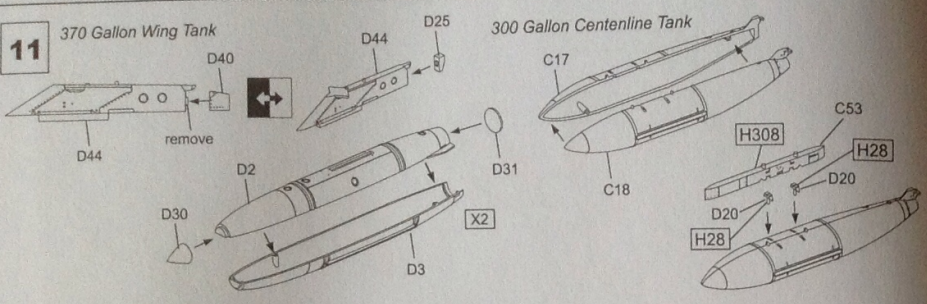

12

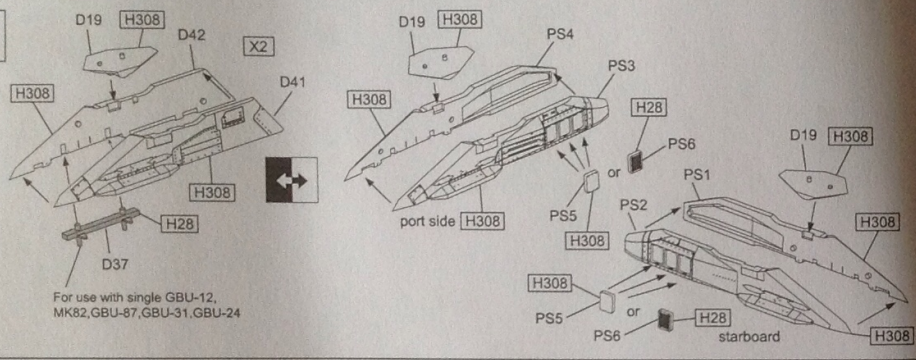

13

AIM-9M

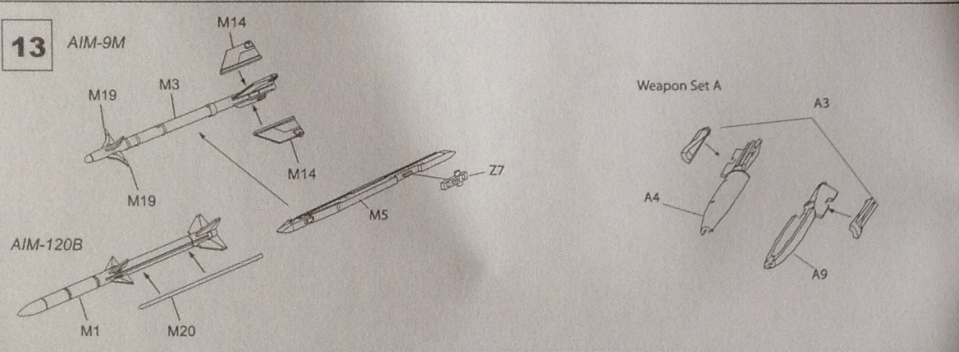

14

AGM-65

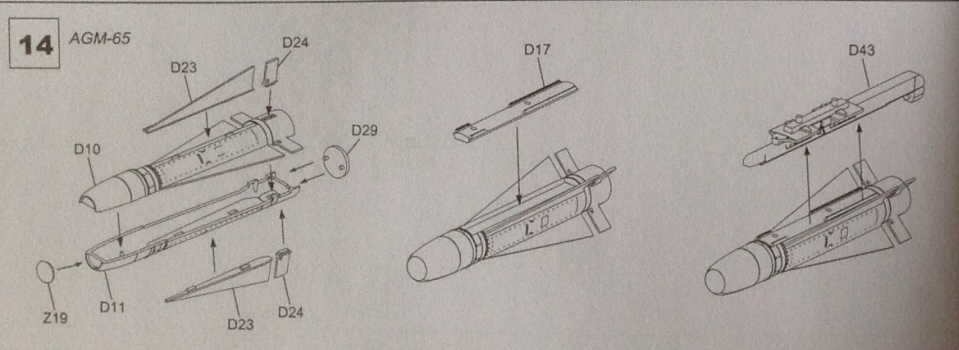

15

GBU-31

GBU-87

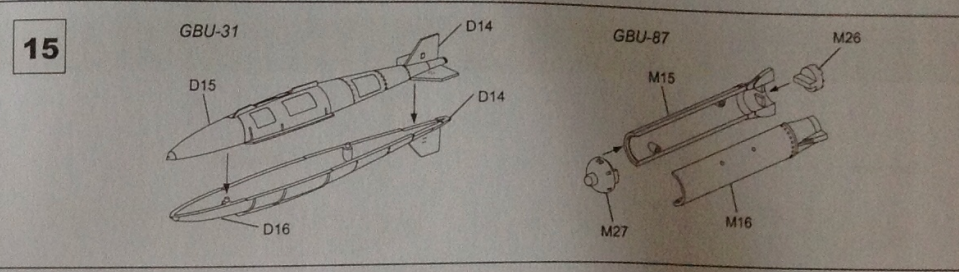

16

GBU-12

GBU-24

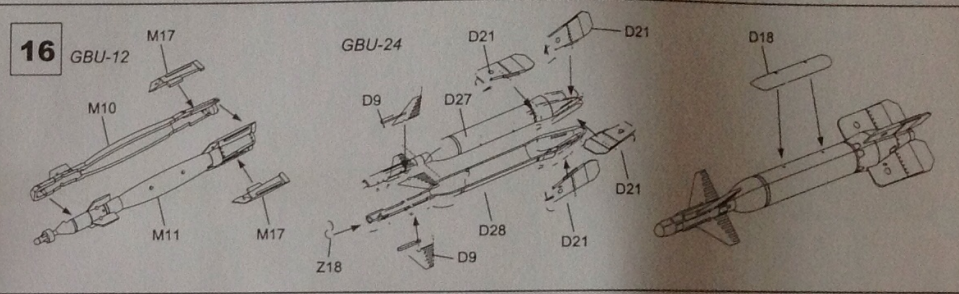

17

AN/AAQ-13

AN/AAQ-14

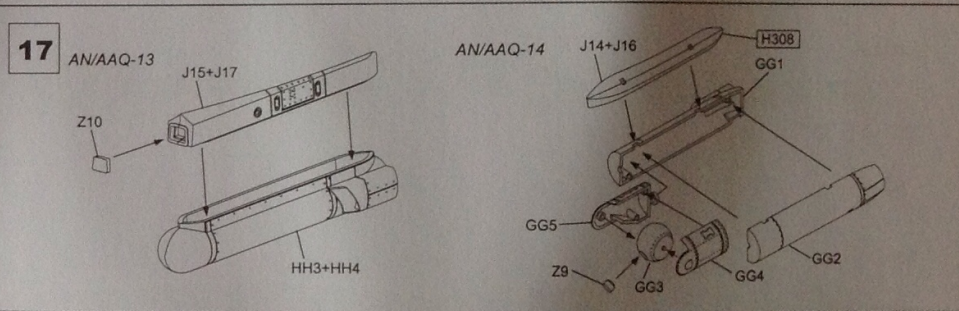

18

XC22,24,26,28,30,32,34,36, 38,40,42,44,46,48,50,52

TER

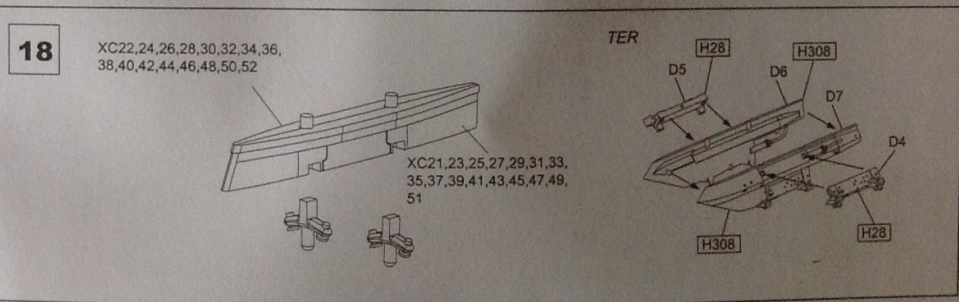

Painting & Decal Placement - External Stores

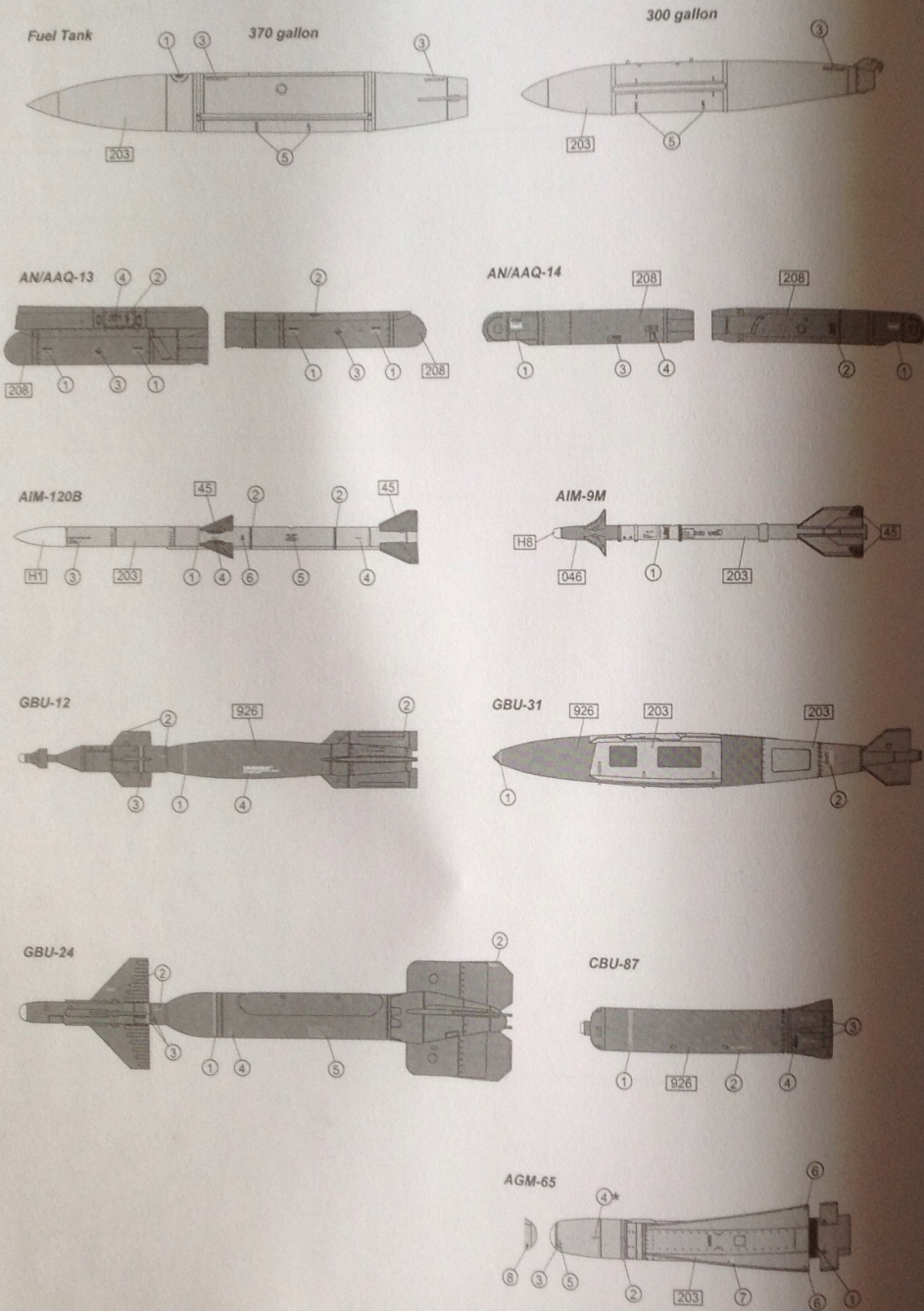

External Stores

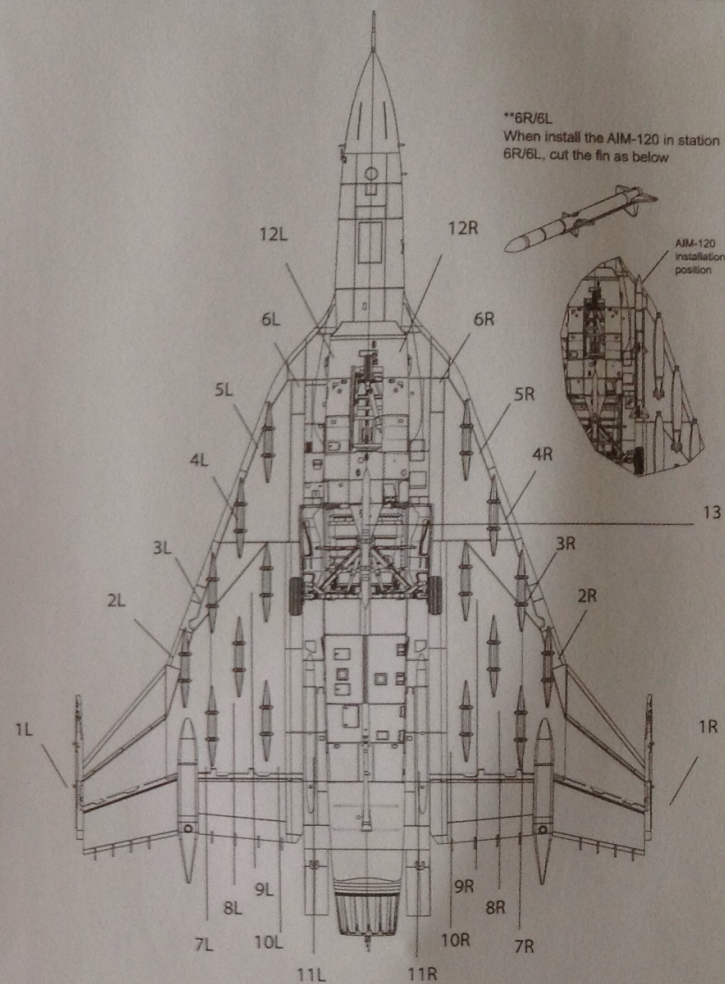

WEAPON	HARD POINT												
	1L/1R	2L/2R	3L/3R	4L/4R	5L/5R	6L/6R	7L/7R	8L/8R	9L/9R	10L/10R	11L/11R	12L/12R	13
AIM-9M	●												
AIM-120B						●						●	
MK82		●	●	●	●		●	●	●	●			
GBU-12		●	●	●	●								
GBU-31		●	●	●	●		●	●	●	●			
GBU-87													
GBU-24		●											
AGM-65			●	●	●								
370 GAL TANK			●										●
300 GAL TANK												●	
AAQ13/14													●
ALQ-131													●

1. F-16XL, Prototype scheme, 1982.

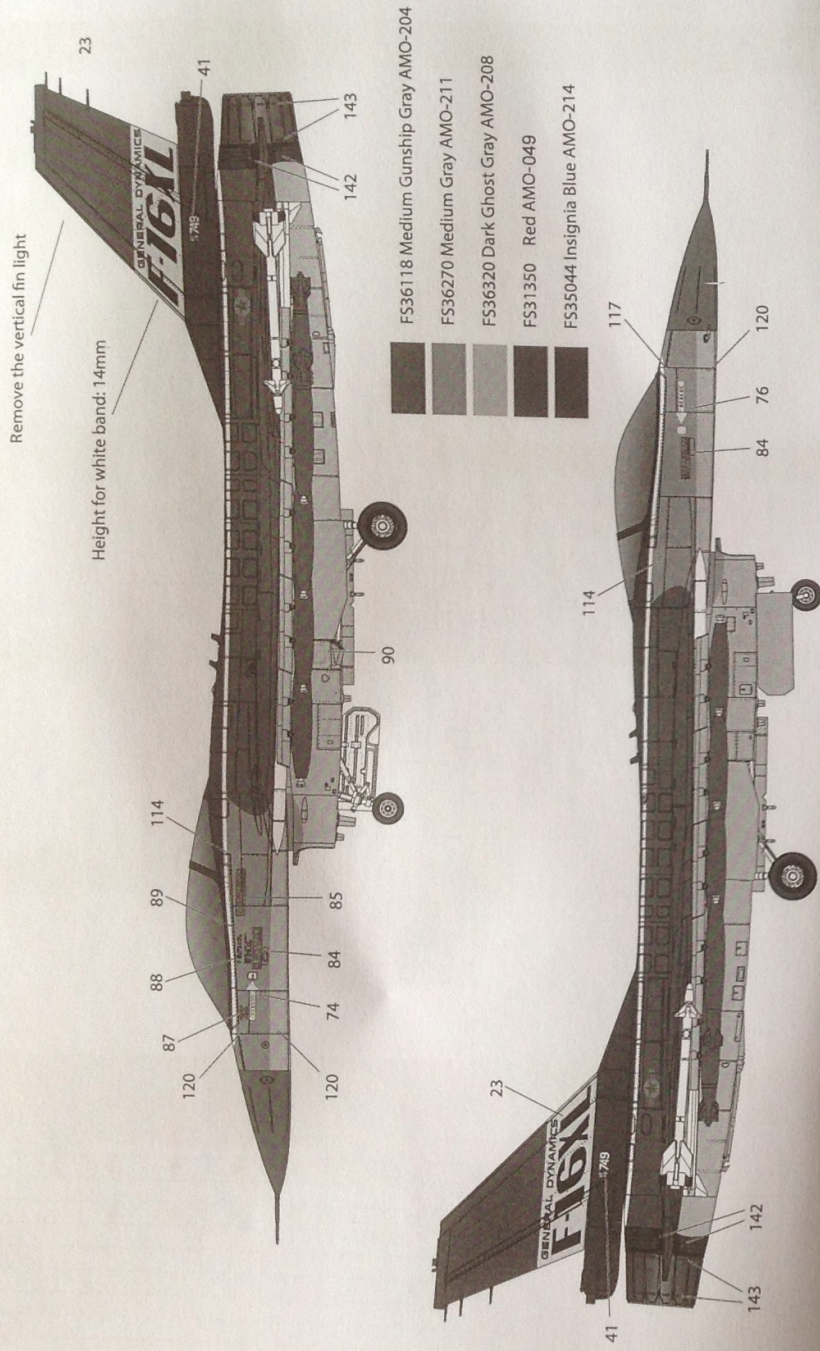

- FS36118 Medium Gunship Gray AMO-204
- FS36270 Medium Gray AMO-211
- FS36320 Dark Ghost Gray AMO-208
- FS31350 Red AMO-049
- FS35044 Insignia Blue AMO-214

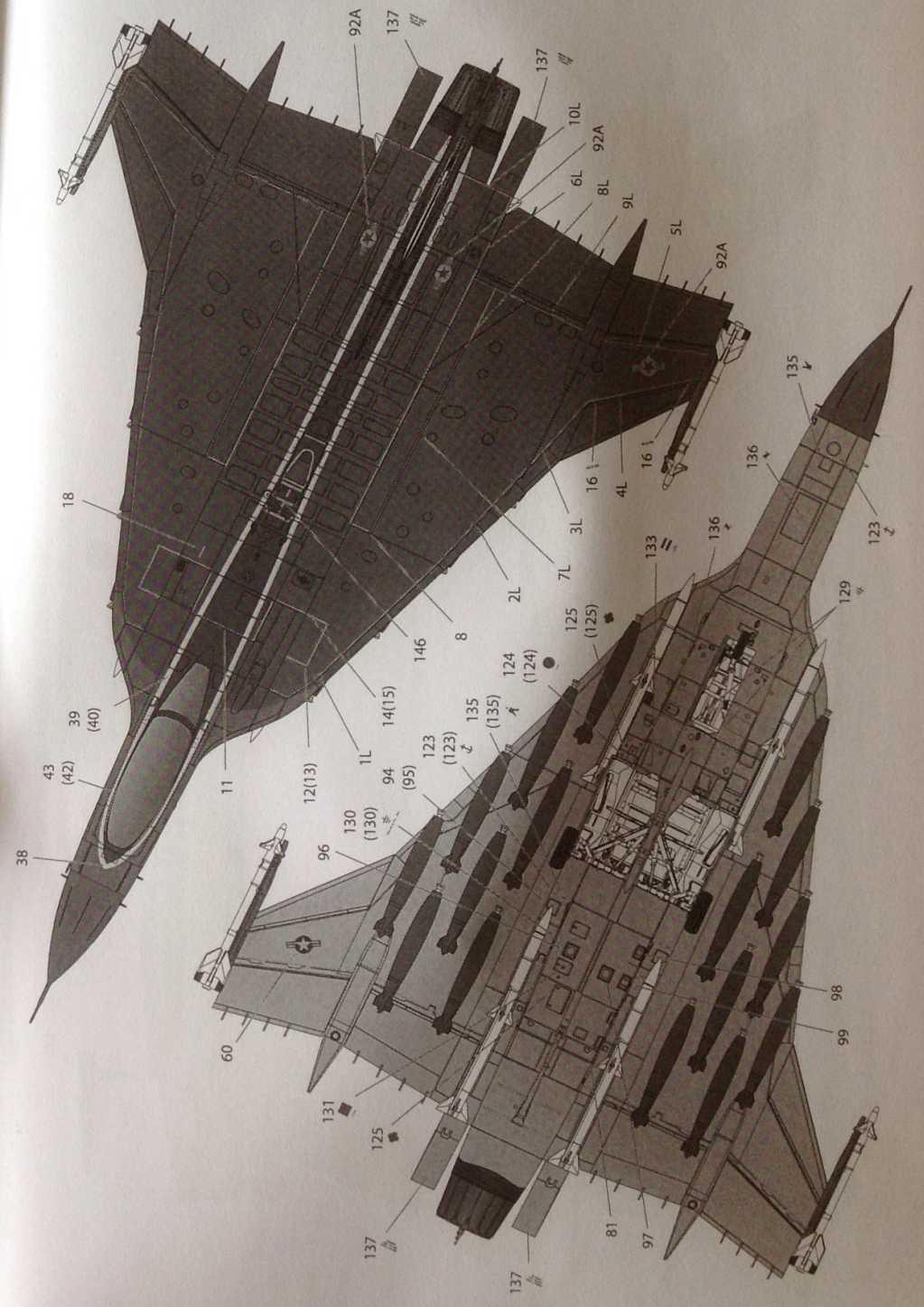

2. F-16XL, NASA, 1993~

Painting and marking
has been changed, as:

* : 1995~1997

** : 1997~

*** : 1999~

**** : 2007~

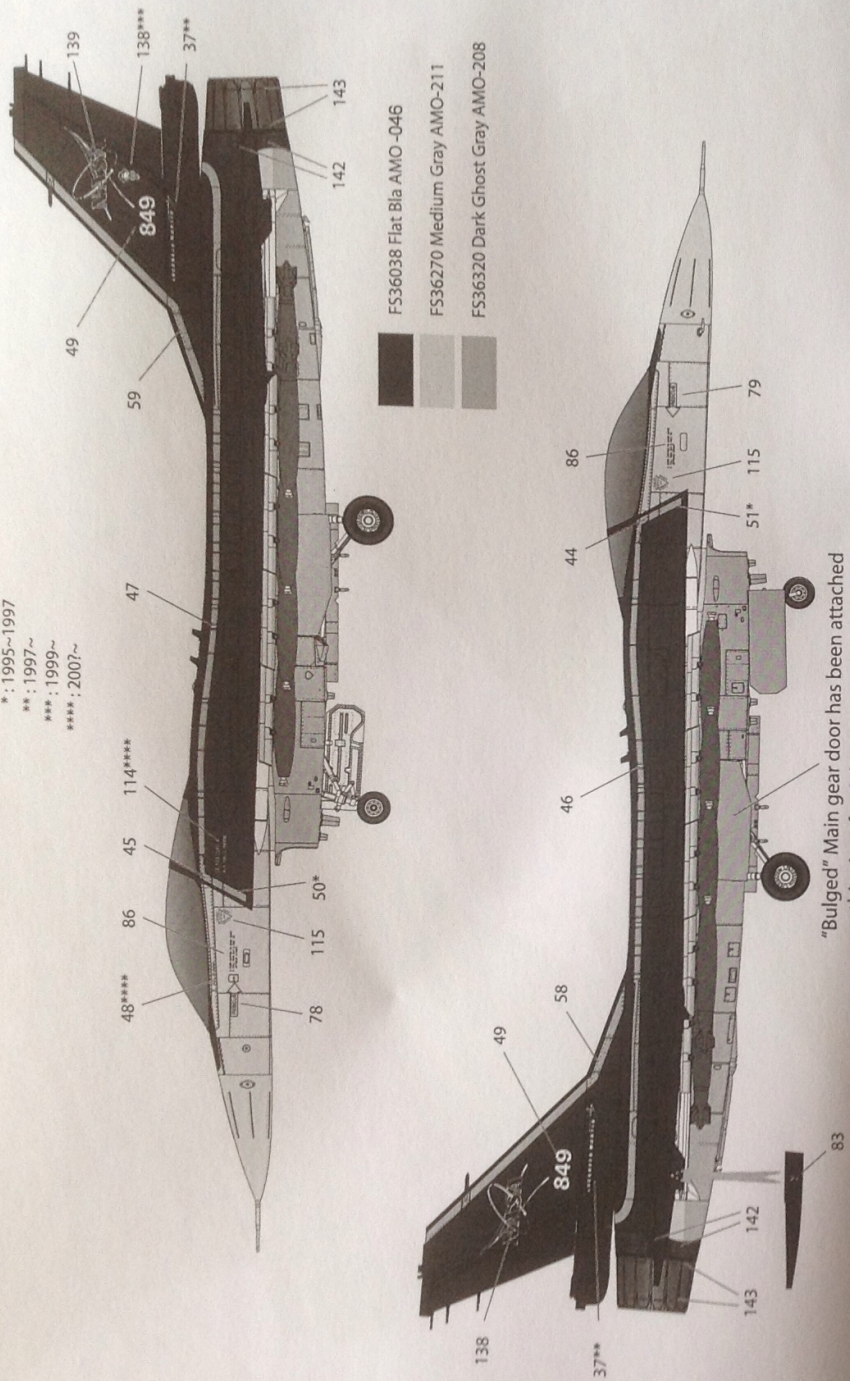

"Bulged" Main gear door has been attached
on this aircraft t's lease to NASA in 1989.

except black sidewinder-lookalikes seen around 1997.

Note: Actual NASA F-16XL has never armed

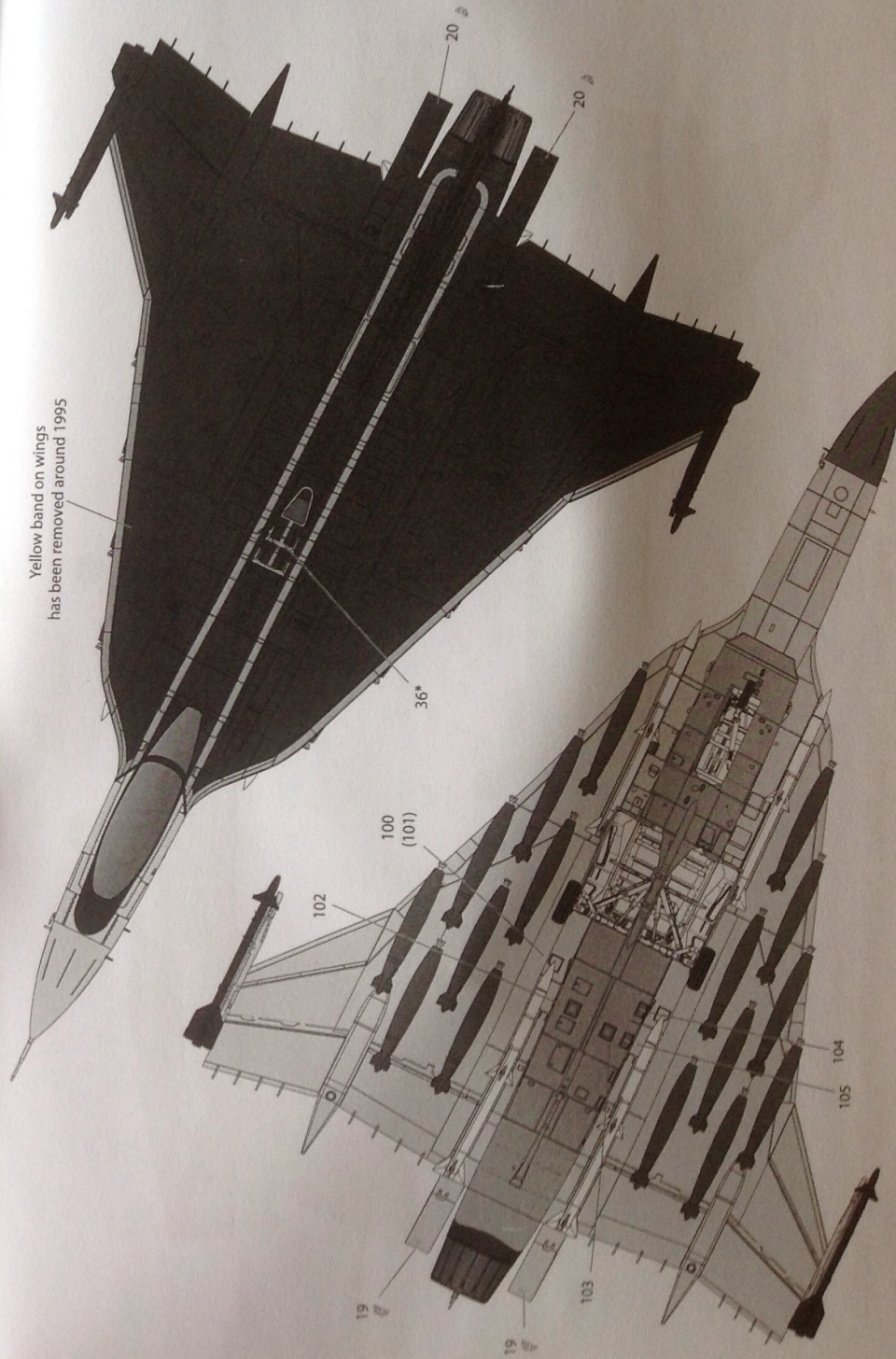

3. F-16XL, 75th Fighter Squadron, 23d Wing "Flying Tigers", USAF, 1995: Fictional

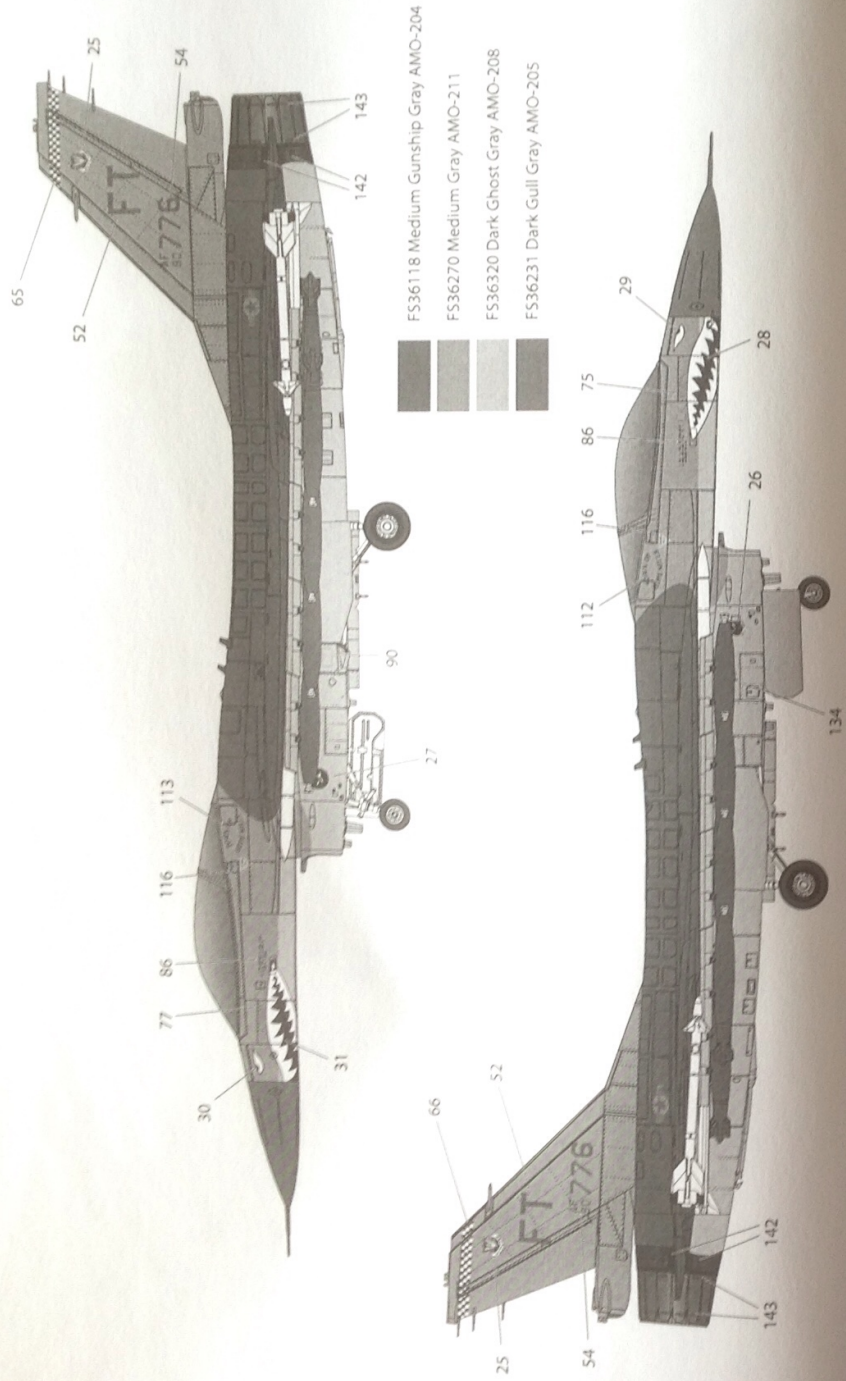

Note: 75th SQ, sister squadron of 74th, actually operates A-10A and "Town of Hope Mills" has been marked on A-10A 80-0252.

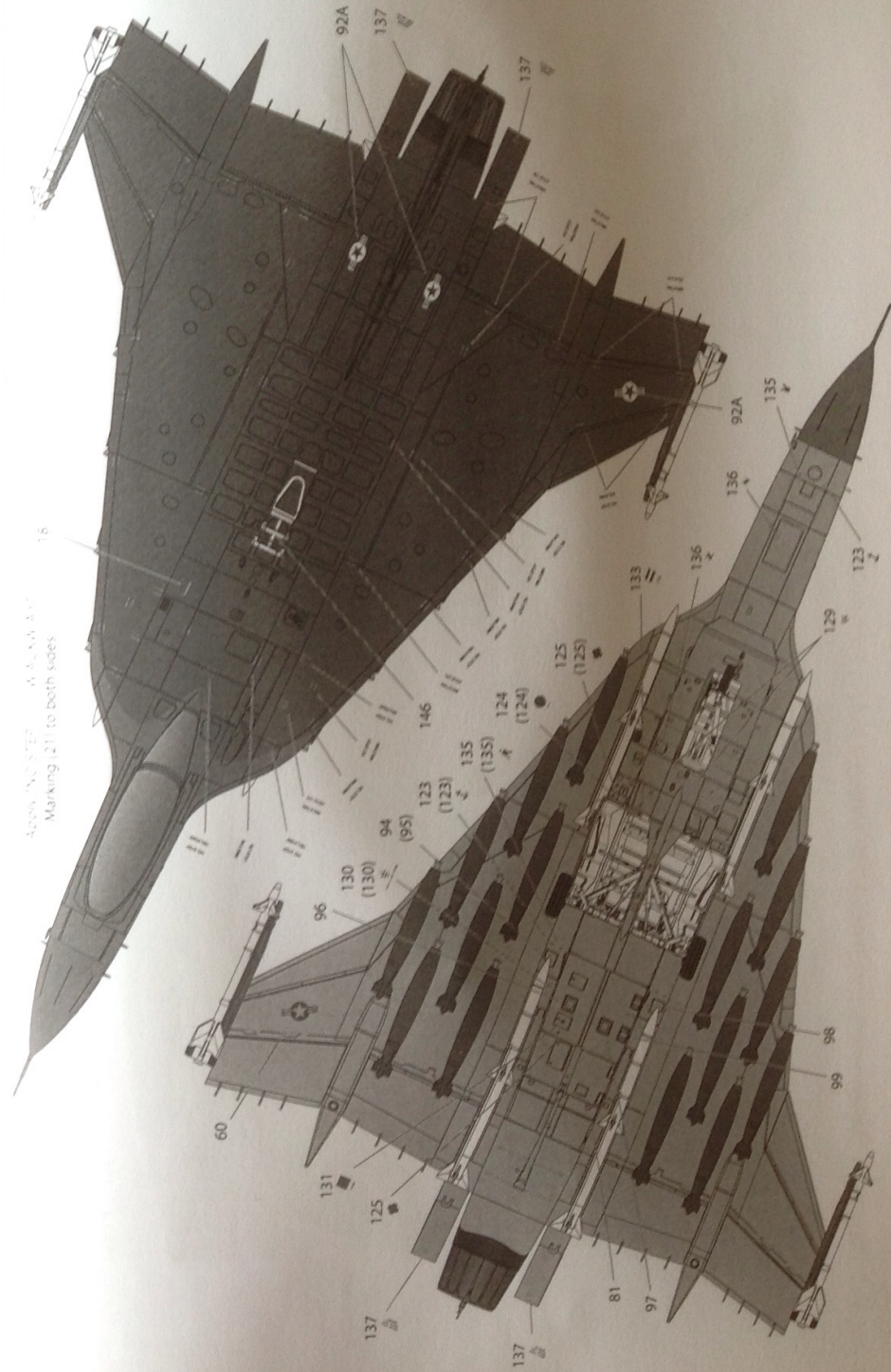

5. F-16XL, Tayeset (Squadron) 101, Israeli Defence Force : Fictional

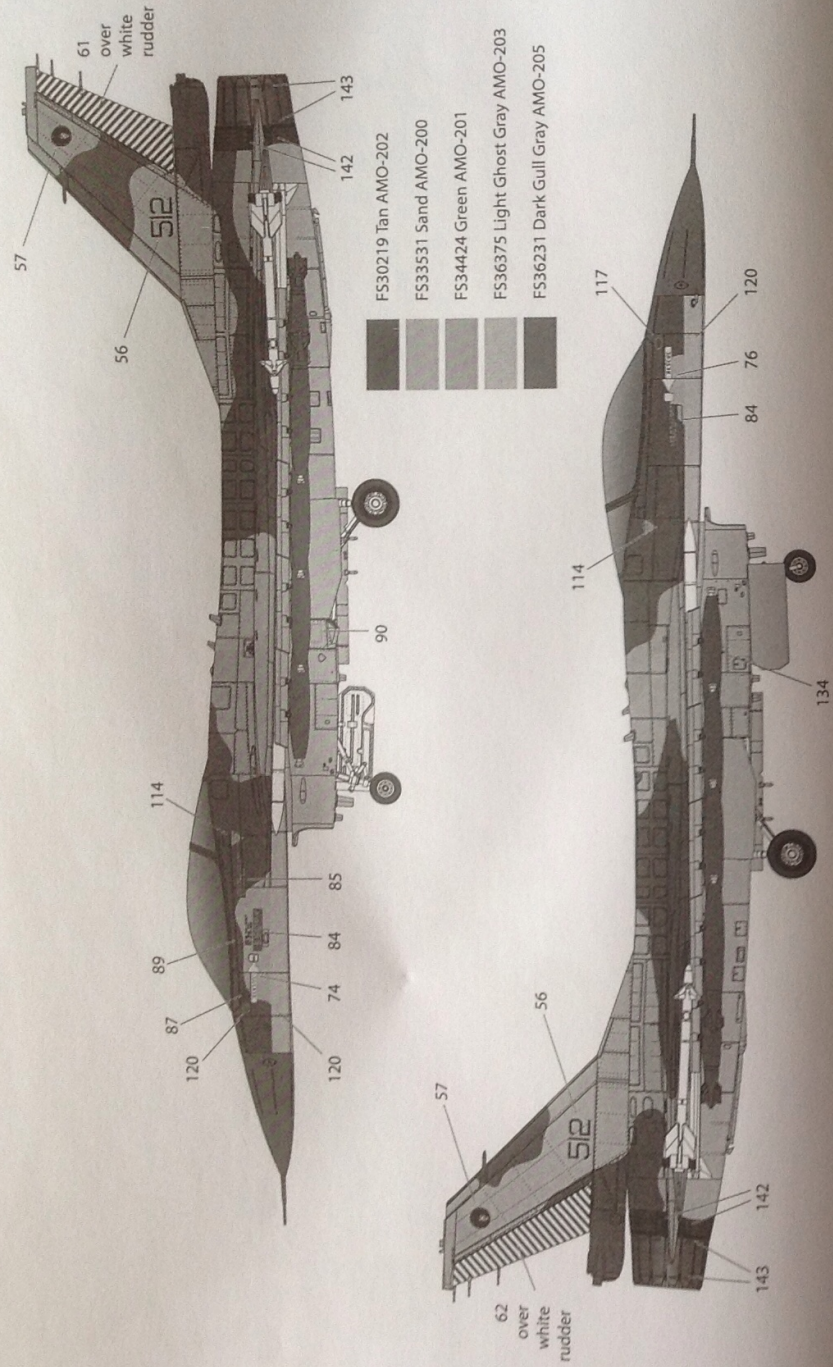

Note: IDF no. 512 actually is a F-16C Block 40, assigned to the same squadron.

