



©2018

1/72 scale
Bell 412 HR.2 Griffon
84 Sqn. RAF Akrotiri
Update Set
Set # WBA72155

Introduction

After having served in Aden, the squadron was reformed in Cyprus on 17 January 1972 from 1563 Flt and a detachment from 230 Sqn. with Westland Whirlwind HAR.10s at RAF Akrotiri. The squadron was also based at Nicosia International Airport to aid UNFICYP operations and operate search and rescue. It later (December 1981) replaced the Whirlwind with the Westland Wessex HC.2 and later still (June 1984) with the Westland Wessex HU.5C. It was the last squadron to use the Westland Wessex.

No. 84 Squadron was the first RAF contingent into Beirut in the Lebanese Crisis of 1983. This resulted in the evacuation of the peace-keeping element from the city.

Since January 2003 the squadron has been assigned to British Forces Cyprus at RAF Akrotiri in the search and rescue role using the Bell Griffin HAR.2. The helicopters are leased from and maintained by a civilian company. 84 Squadron aircraft are also used for UN duties in maintaining the buffer zone separating Cypriot and Turkish forces. In recognition of this role the aircraft are always unarmed and carry a light blue band around their tail, matching the blue berets of UN peacekeepers. These aircraft are the subject of this Detail Set.

84 Squadron is the only serving squadron never to have been based in the United Kingdom.

What you get - resin parts: *Preparation: general instructions*

replacement cabin doors
flotation gear + mountings
FastFin tail unit
replacement exhaust - extended pipes
winch, winch pylon and connecting block
Decca box
SARBE mount
air vents for above nose
cargo hook well
2 x IR detectors for tail boom
3 x whip aerial mounts
3 x under fuselage lamps
2 x domes - alongside engine housing
upper position light
lower position light
small port cabin door with dinghy pack
large landing light - under fuselage
rounded avionics housing
blade aerial - cockpit roof
position light - starboard cabin roof
IR floodlight
spotlight on cabin roof aft of air intake
spotlights on tail boom
Small round dome on centre line
Light unit at junction of fuselage and tail boom

Remove resin parts carefully from the moulding blocks to which they are attached using a scalpel or razor saw.. Sand lightly to remove any roughness and tidy up any mould lines - remember that resin dust can be harmful; we therefore suggest that you use a mask when sanding, and sand wet rather than dry.

Note that some masters have been produced using 3-D printing, and the parts therefore have an extensive support framework which must be removed with great care to avoid damage.

Resin and etched brass items can be attached with cyanoacrylate adhesive.

produced by

Whirlybird,
73 High Street,
Wombwell,
BARNSLEY, South Yorks.
S73 8HS ENGLAND
+44 (0)1226 345635
sales@whirlybirdmodels.com
Website:
www.whirlybirdmodels.com



©2018

*custom decals for
the discerning
modeller*

Etched brass fret:

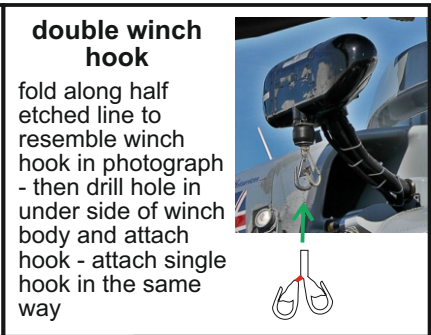
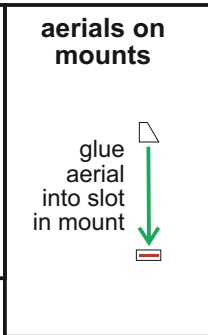
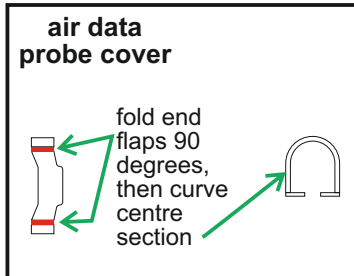
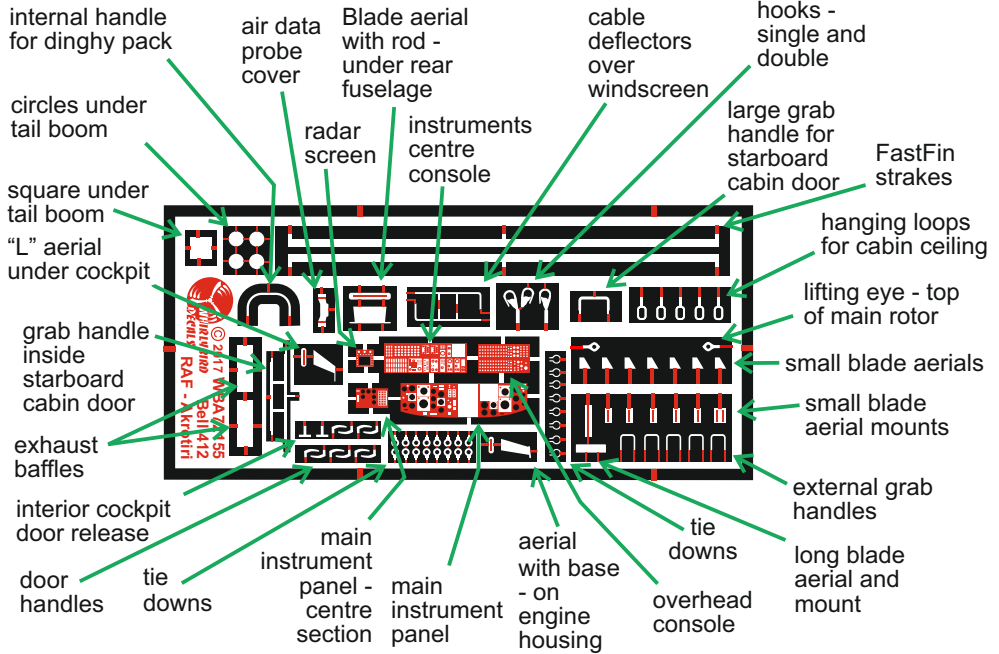

Construction Notes

This Update Set is designed for the Italeri Bell 412 kit. The kit has been released in several different versions - any will do. Make the kit using the kit instructions, except as detailed here.

- Remove from underside of fuselage and smooth - light fitting under nose and mounting for cargo hook.
- Make hole in underside where cargo hook mount was (6mm).
- Remove position light on cabin roof (stbd) and replace with resin part provided as indicated (*port side remains as in kit*)
- Fill in location point for single blade aerial on front section of engine housing fairing (part 40A) (*ZJ705 has twin small swept blade aerials there - aerial not on any other 84 Sqn. Griffin*)
- NB: Different configurations of front section of cabin door - Seems to depend on whether flotation gear is fitted or not e.g. ZJ703 - 4 Jul 2009 no flotation gear - stbd front section RED ORANGE with window - 16 Nov 2010 with flotation gear - stbd front section GREY with no window

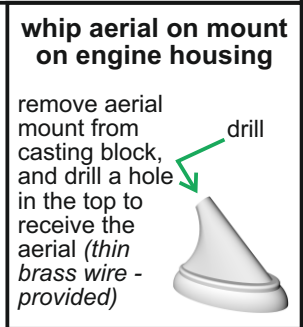

Cockpit

remove engraved detail from kit part 1B, and add centre console



add radar screen and centre section to main instrument panel, and glue to part 16B after removing raised detail

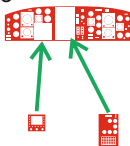

remove engraved detail from kit part 17B, and add overhead console

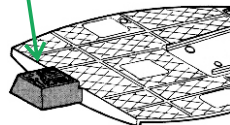
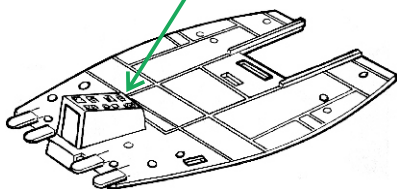

Use the other cockpit and cabin parts as supplied in the Italeri, Astrokit or Revell kit.

Because the 84 Sqn. Bell 412s carried a lot of extra fittings and equipment in the cabin, **WHIRLYBIRD** have produced a Detail Set for the cabin (**WHIRLYBIRD** part no. WBA72162 - Bell 412 HR.2 Griffon - Interior set) which provides some of the items such as crew seats, fire extinguishers, a new starboard cabin bulkhead etc. which would be difficult to scratch build. This is available from **WHIRLYBIRD** direct, or from **WHIRLYBIRD** stockists.

Airframe - starboard side, starting from nose going aft

blade aerial with rod on roof of engine compartment

remove position light from cockpit roof, and replace with resin unit in this position

grab handles on side of fuselage and on cockpit roof - both sides

2 vents (to clear water from wind-screen - one each side)

use kit radar nose and pitots

air data probe cover

add tie from end of skid to skid support - both sides

flotation gear - see later for construction

door handles

kit part 99A

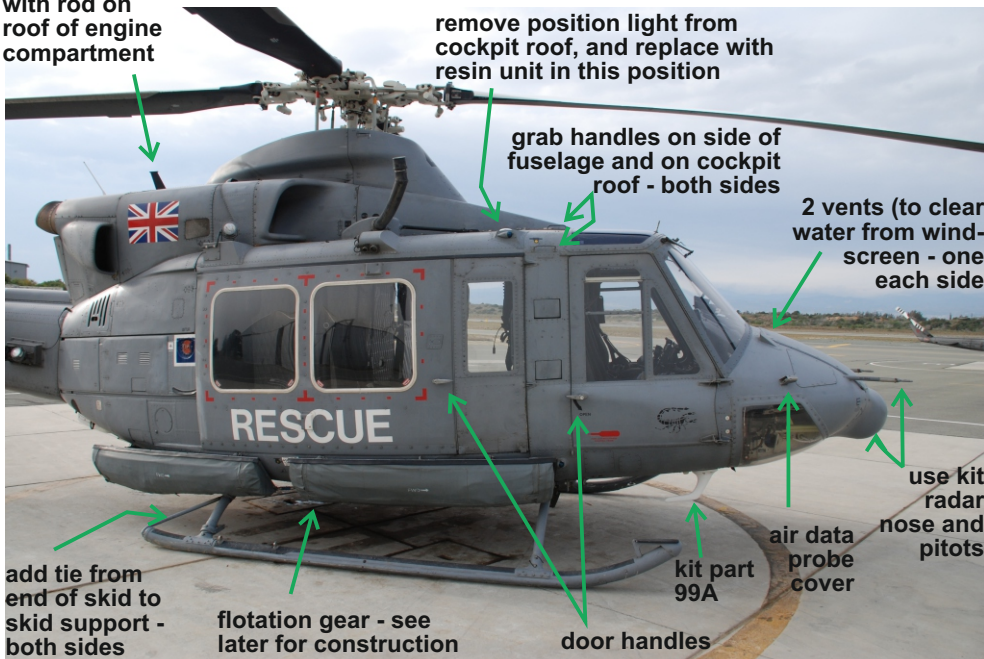

Airframe - starboard side, starting from nose going aft continued

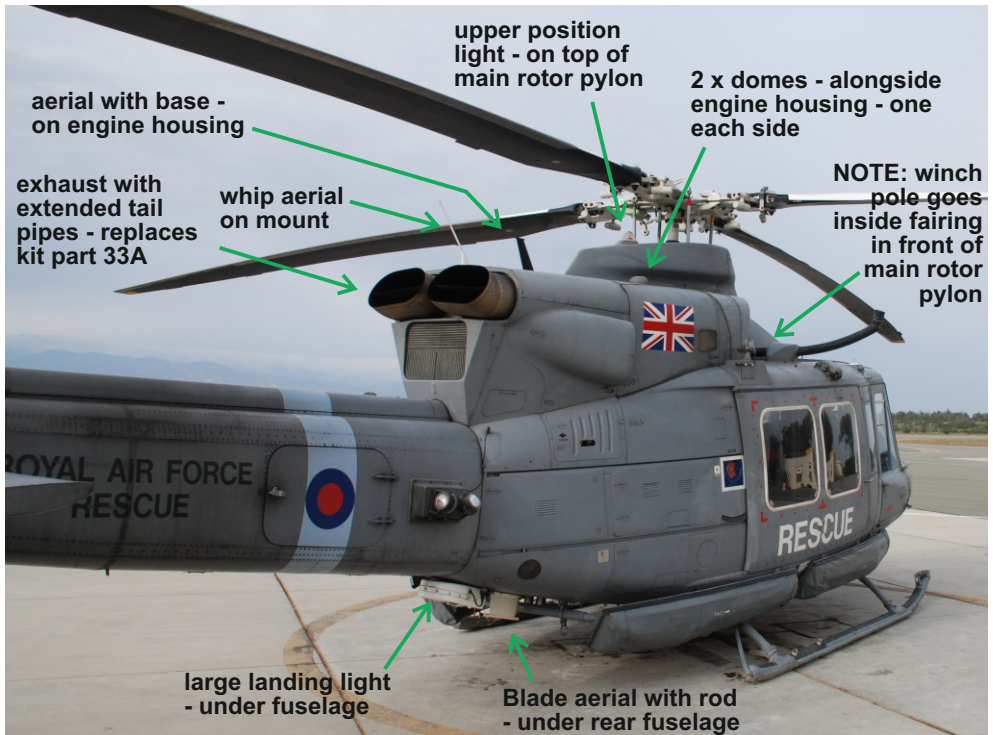
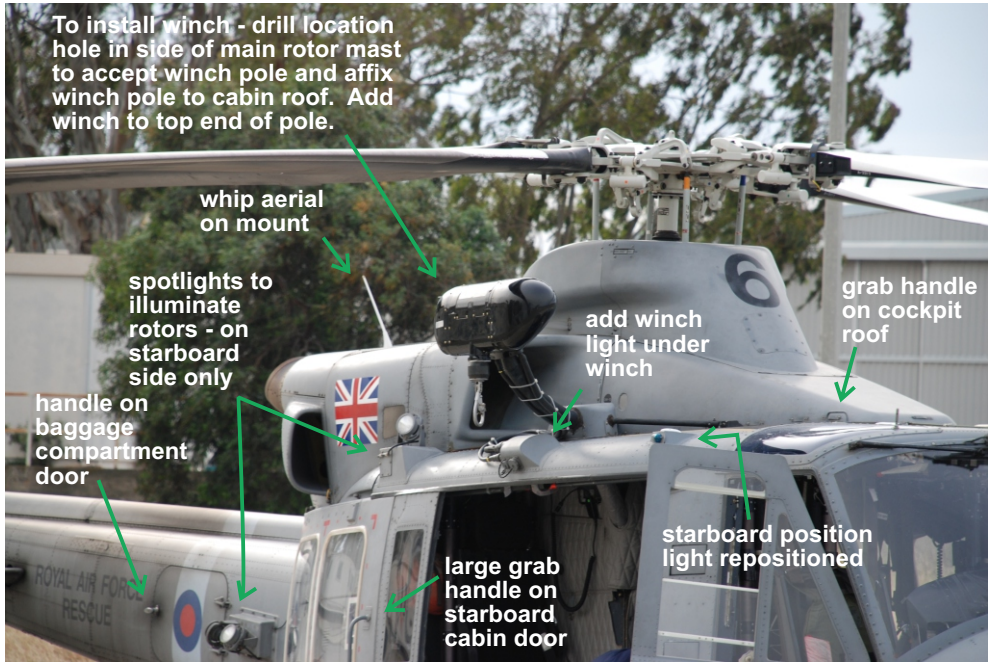

Airframe - port side, starting from nose going aft

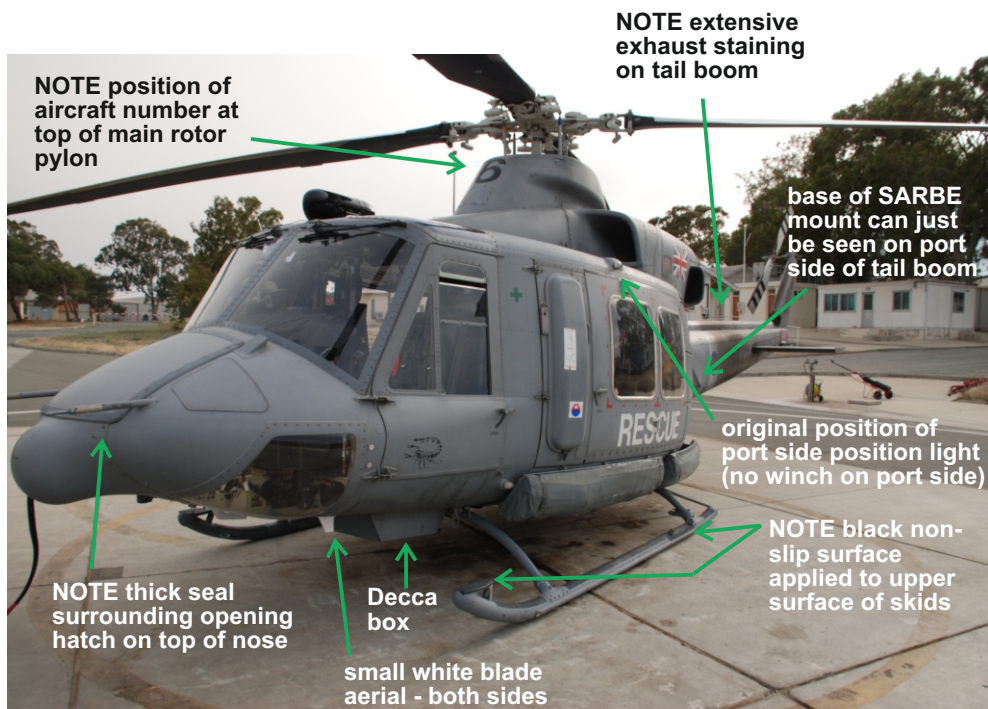

Under aircraft - view from front

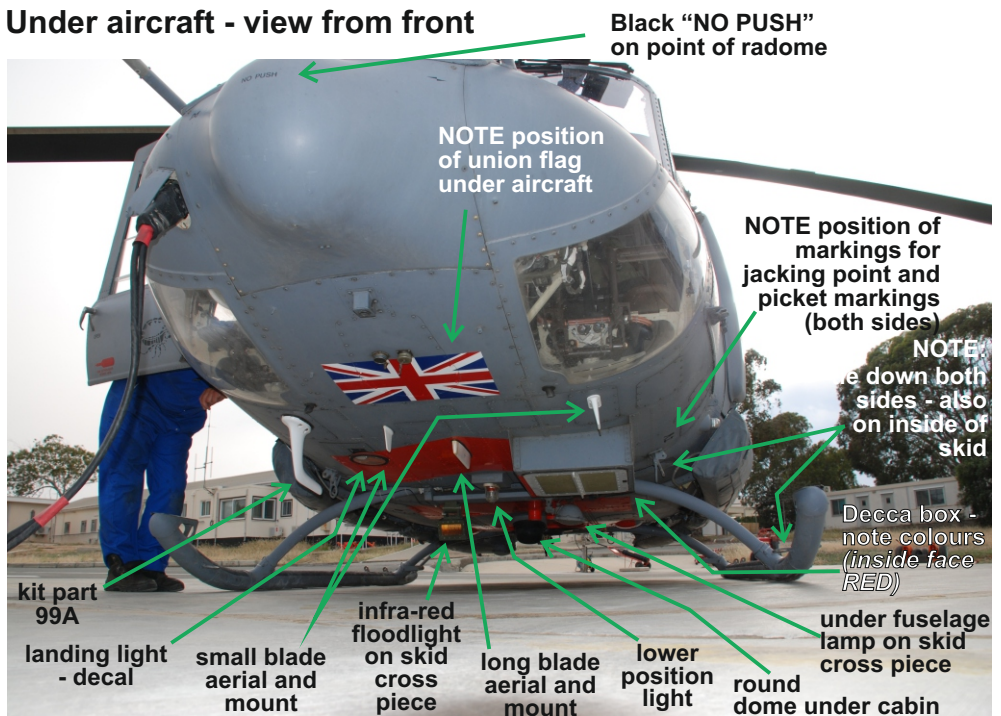

Under aircraft - view from rear

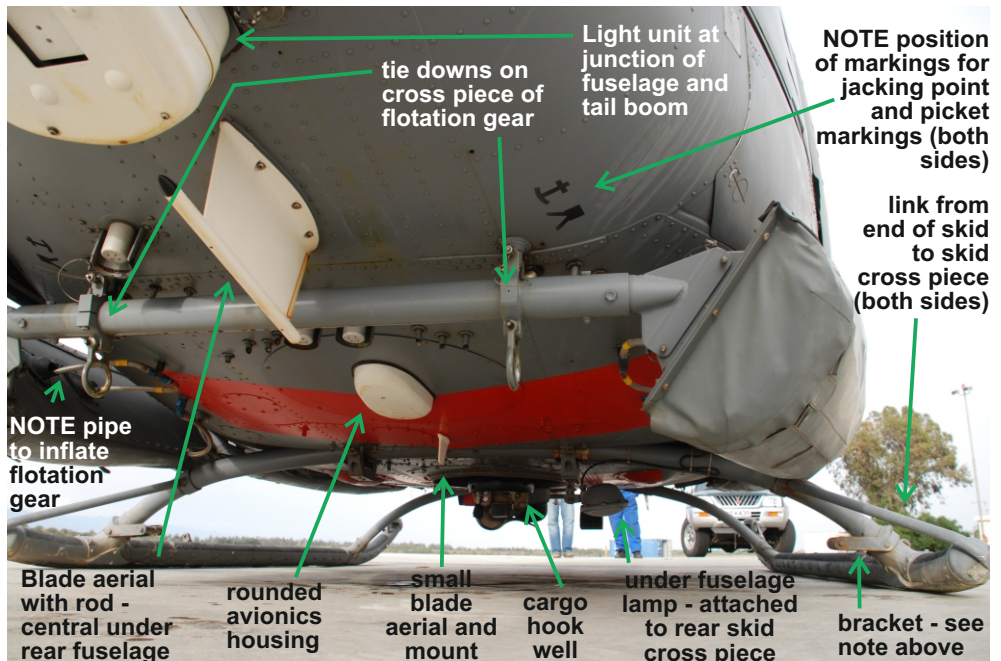

Flotation gear

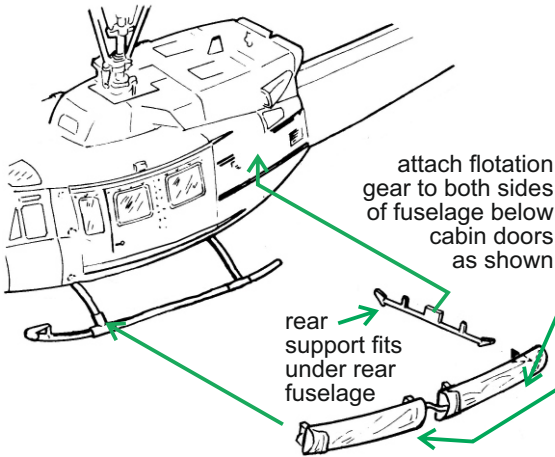
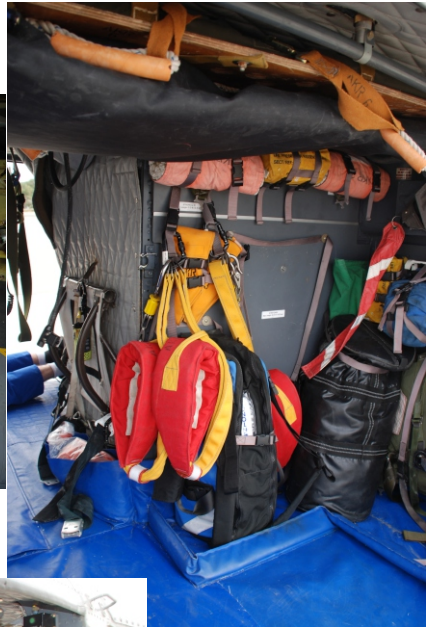

diagram shows flotation gear being fitted to a Bell 212 - the 412 is similar.

usually dark grey - almost black

overhead windows tinted dark blue



these 2 photographs give a glimpse of the interior of the cabin, with all the rescue and survival equipment and crew seats etc.

WHIRLYBIRD produce a Cabin Detail set which provides many of the items which would be hard to scratch build to detail the cabin. Set **WBA72162 Bell 412 HR.2 Griffon - Interior set**



Some more detail shots

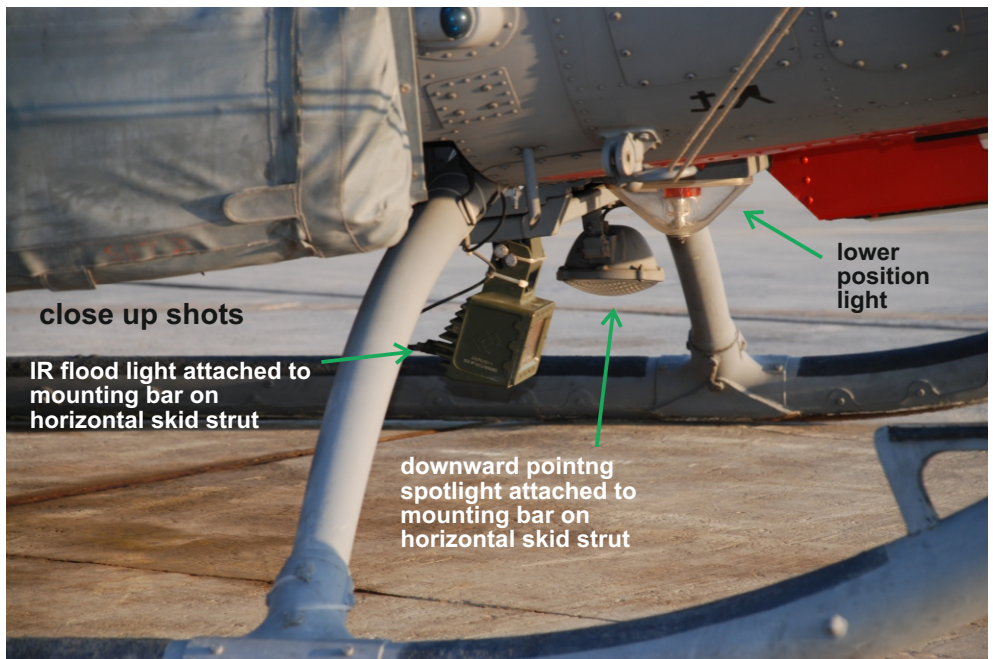
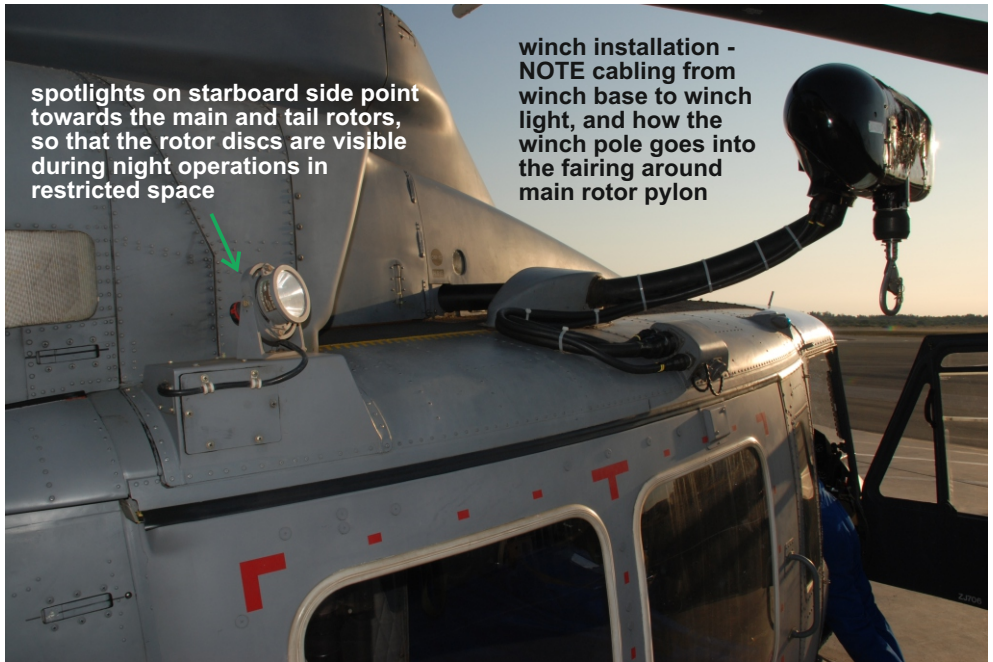

Grateful thanks to Nick Turner, who provided all the photographs and has generously allowed us to reproduce them here. All photographs copyright Nick Turner ©