

# Curtiss P-40E Kittyhawk 1a

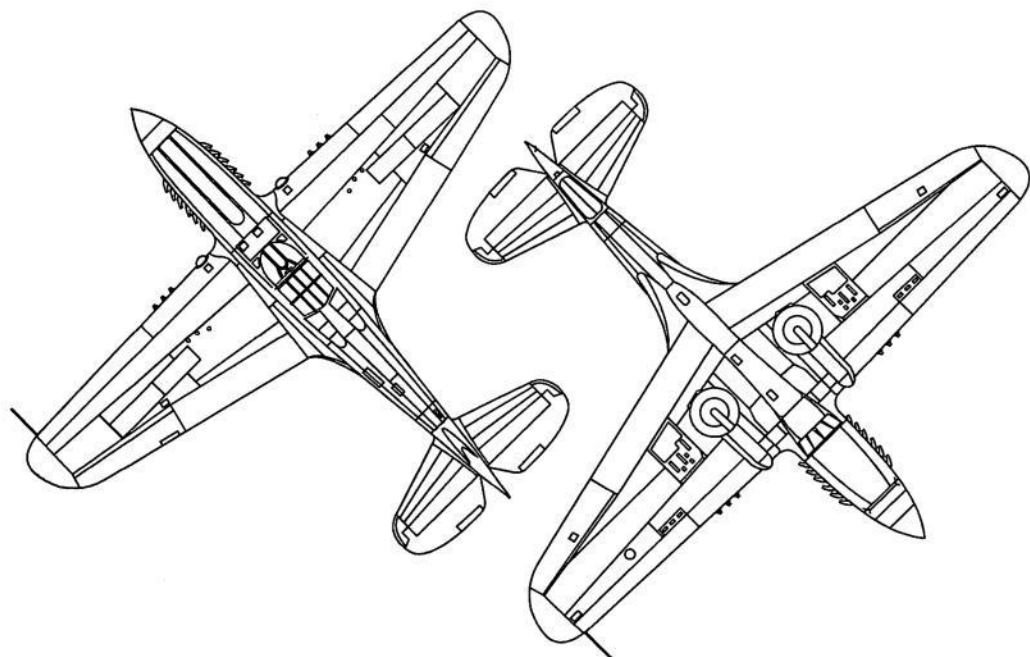
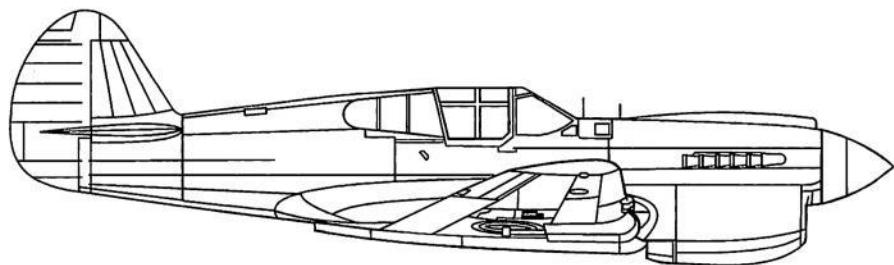
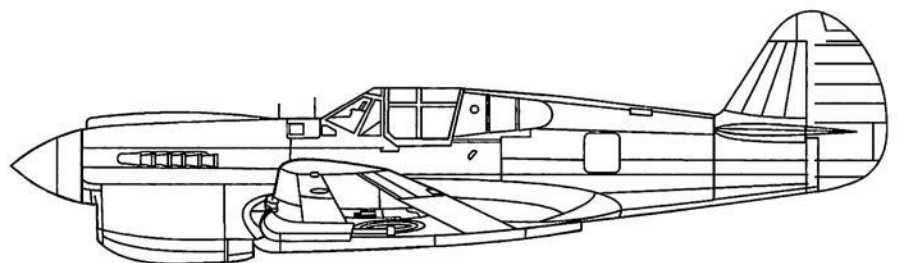

**AZmodel**  
Plastic kits

# Curtiss P-40E Kittyhawk 1a

Plastic kits

Scale 1/72

The Curtiss P-40 Warhawk was an American single-engine, single-seat, all-metal fighter and ground attack aircraft that first flew in 1938. The P-40 design was a modification of the previous Curtiss P-36 Hawk which reduced development time and enabled a rapid entry into production and operational service. The Warhawk was used by the air forces of 28 nations, including those of most Allied powers during World War II, and remained in front line service until the end of the war. It was the third most-produced American fighter, after the P-51 and P-47; by November 1944, when production of the P-40 ceased, 13,738 had been built, all at Curtiss-Wright Corporation's main production facilities at Buffalo, New York. The P-40E or P-40E-1 was similar in most respects to the P-40D, except for a slightly more powerful engine and an extra .50 in (12.7 mm) gun in each wing, bringing the total to six. Some aircraft also had small underwing bomb shackles. Supplied to the Commonwealth air forces as the Kittyhawk Mk 1A. The P-40E was the variant that bore the brunt of air-to-air combat by the type in the key period of early to mid 1942, for example with the first US squadrons to replace the AVG in China (the AVG was already transitioning to this type from the P-40B/C), the type used by the Australians at Milne Bay, by the New Zealand squadrons during most of their air to air combat, and by the RAF/Commonwealth in North Africa as the Kittyhawk 1A.

We would like to express our thanks to Mr. Terry McGrady for his help with the kit.

Plastic part

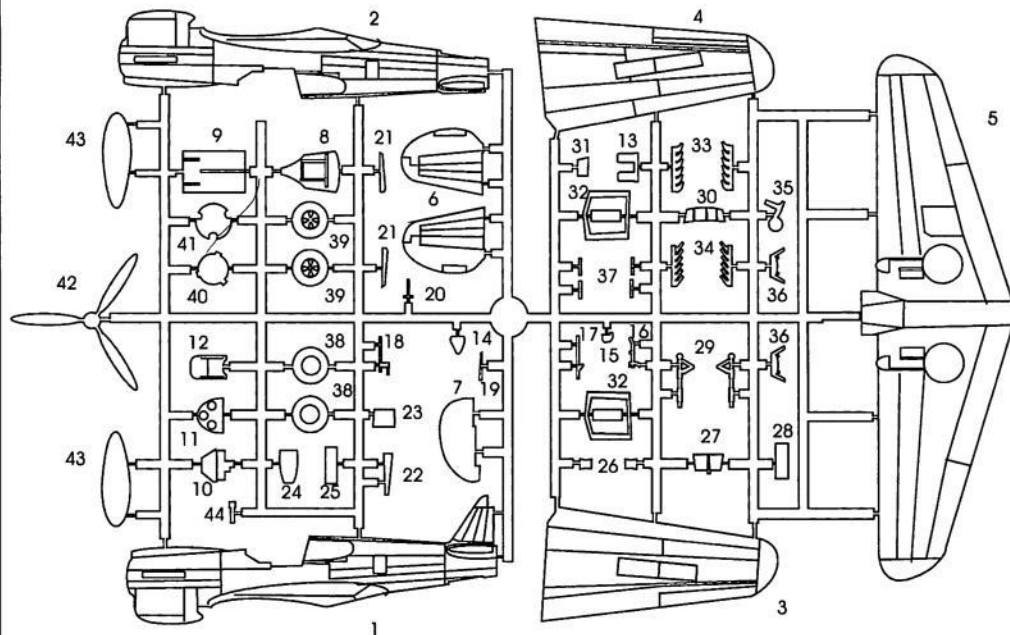

Transparent part T1



T2



T2

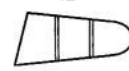

Photo-Etched parts



P-40E  
AZmodel

| Colour name      | Number | Colour name  | Number |
|------------------|--------|--------------|--------|
| A Black          |        | F Silver     |        |
| B White          |        | G Gunmetal   |        |
| C Interior Green |        | H Dark Brown |        |
| D Light Grey     |        |              |        |
| E Dark Grey      |        |              |        |

