

G.W.H.[®]

1/48 SCALE L4824



SU-27

"FLANKER B" HEAVY FIGHTER
Su-27 "侧卫B" 重型歼击机

Special thanks to design supervisors Yufei Mao, Gabor Szekeres and Alexander Drannikov

A Part x1

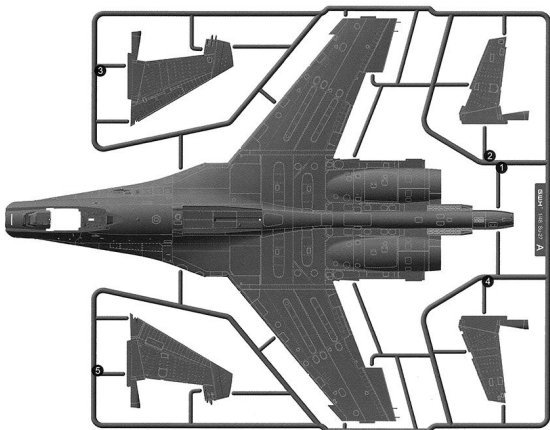

C Part x1

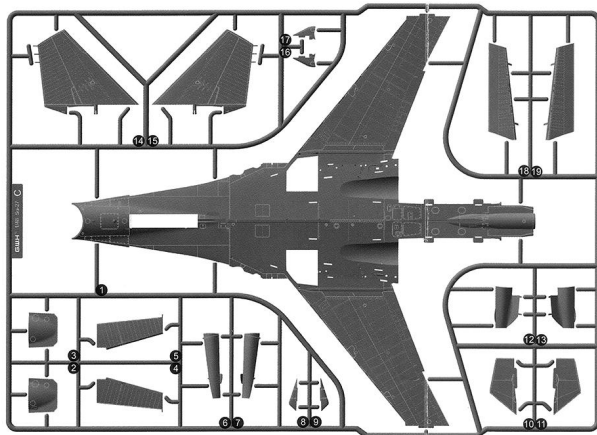

D-1 Part x1



D-2 Part x1



E Part x1

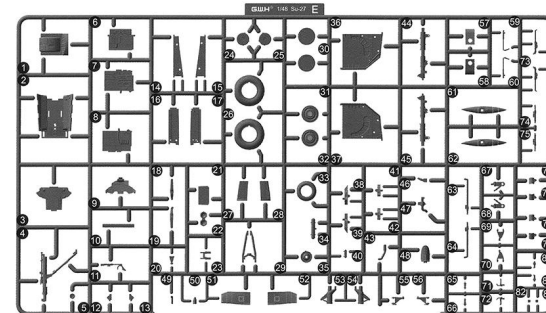

V1 Part x1



Twin Part x2

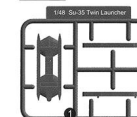

H Part x1



F Part x1

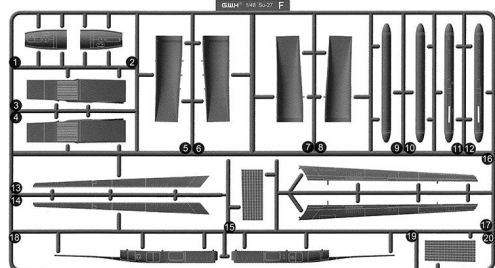

X Part x1

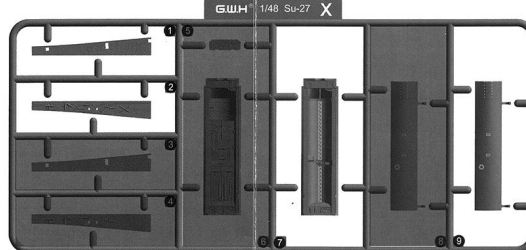

P Part x1

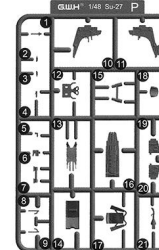

AKU-470 Part x2

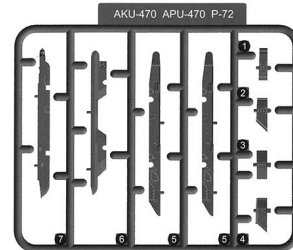

B-13L Part x4

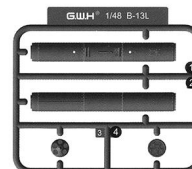

W Part x1

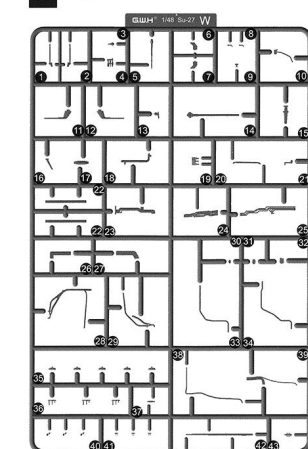

I Part x2

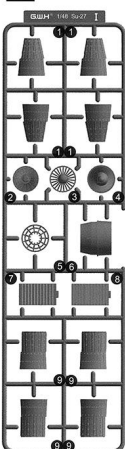

BD3 Part x2

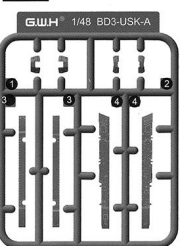

Q Part x1



R-73E Part x4



R-27ET Part x2



R-27ER Part x4



N Part x1

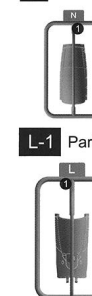

L-1 Part x1



U Part x1

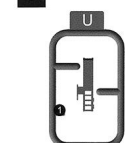

Twin Part x2

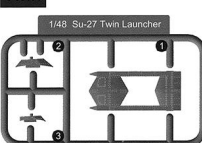

S Part x1



R Part x1



L Part x1

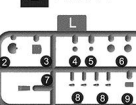

阴影零件不使用
DO NOT USE THE
SHADOW PARTS

Decal A



PE 1



PE 2

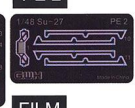

FILM



Decal B



Decal C

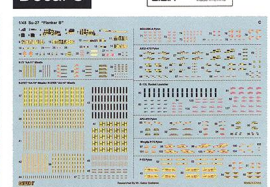

注意事項 CAUTION 組み立てのご注意

- (1) 勿于近火处使用胶水或油漆, 并打开窗户保持空气流通。
- (2) 涂料的号码请参考本栏以下的说明。本品本身不包括胶水和涂料。
- (3) 自板件中取出部件时, 应用模型专用剪, 并用介刀或小锉除去多余胶料。
- (4) 各图形的含义可参考本栏以下说明。

- (1) When you use glue or paint, do not use near a open flame, and use in a well-ventilated room.
- (2) See below for the color list. Glue and paint are not included in the kit.
- (3) When you take parts off the runner frame, use the modeling scissors and trim excess plastic with a cutter or a file.
- (4) See below for the meaning of symbols.

- (1) 接着剤や塗料は火の近くで使わないで下さい、使用の際は換気をよくして下さい。
- (2) 塗料指定のは下記のとおりです、接着剤や塗料は入っていませんので別に求めて下さい。
- (3) 部品のランナーから切り離す時は模型用ハサミ等を使い、余分な部分はカッターやヤスリ等で仕上げて下さい。
- (4) 組立図のサインマークは下の説明を御覧下さい。

图形含义 CAUTION マーク



填平
FILL HOLE
穴を埋めて下さい



水印粘紙
APPLY DECAL
デカールを貼って下さい



切除
CUT OFF
切り取って下さい



弯折
BEND
折り曲げて下さい



制作两组
MAKE TWO SET
2個作って下さい



另一側相同制作
DO THE SAME ON THE OPPOSITE
反対側も取り付けます



胶水
CEMENT
接着して下さい



钻孔
OPEN HOLE
穴を開けて下さい



选择使用
OPTIONAL
どちらを選んで下さい



不用胶水
NO CEMENT
接着しないで下さい



注意
BE CAREFUL
注意して下さい



瞬间胶
INSTANT GLUE FOR METAL
瞬間接着剤 (金属用)

所使用工具 RECOMMENDED TOOLS 専用工具

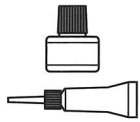

塑胶件用模型胶水
Cement
プラスチック用接着剤

模型用瞬间胶水
Instant Cement
瞬間接着剤

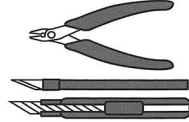

模型用剪钳
Side cutters
模型用ニッパー

模型用刻刀
Modeling knife
模型用ナイフ

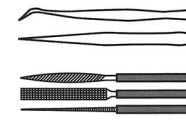

模型用镊子
Tweezers
ピンセット

模型用锉刀
Diamond file
模型用ヤスリ

水贴纸使用说明 DECAL APPLICATION スライドマークの貼り方

- (1) 用模型剪刀或刻刀切下所需的图案部分。
- (2) 将水贴纸浸泡在温水中10秒左右取出放置于戏水的干布上。
- (3) 手拿着水贴纸基的一角, 用模型镊子小心夹住浮起的水贴图案移至模型表面准确位置。
- (4) 用手指适当沾水均匀涂于水贴图案表面, 使其延展移动至精确位置。
- (5) 用柔软吸水的干布将水贴图案中的气泡向一边挤出, 使水贴在模型表面保持平整。

- (1) Cut off decal from sheet.
- (2) Dip the decal in tepid water for about 10 sec. and place on a clean cloth.
- (3) Hold the backing sheet edge and slide decal onto the model.
- (4) Move decal into position by wetting decal with finger.
- (5) Press decal down gently with a soft cloth until excess water and air bubbles are gone.

- (1) 貼りたいマークをハサミで切り抜きます。
- (2) マークをめるま湯に10秒ほど浸してからタオル等の布の上に置きます。
- (3) 台紙のはしを手で持ち、貼るところにマークをスライドさせてモデルに移して下さい。
- (4) 指に少し水を付けてマークを濡らしてながら、正しい位置にずらしします。
- (5) 柔らかな布でマークの内側の気泡を押し出ししながら、押しつけるようにして水分をとります。

蚀刻片使用说明 PHOTO-ETCHED PARTS エッチングパーツ

- (1) 使用蚀刻片专用剪刀或模型专用刻刀将蚀刻片零件切割下待用。
 - (2) 切割下的零件上有蚀刻片的残留连接点部分, 使用模型专用锉刀细心打模干净。
 - (3) 蚀刻片部分在涂装之前必须使用专用的模型金属底漆打底。
- 注意事项: 蚀刻片很薄外延较为尖锐, 有刮伤手的可能, 在使用之时请务必小心。

- (1) Cut off photo-etched parts using a modeling knife.
 - (2) Carefully remove any excess using a file.
 - (3) Apply metal primer prior to painting.
- Attention, please: Extra care should be taken to avoid personal injury when handling photo-etched parts.

- (1) 切り離す時はカッターナイフを使用してパーツを切り離します。
 - (2) 切り出した時、部品に出張った部品が残っている場合は、ヤスリなどで丁寧に削り落とします。
 - (3) 塗装が必要なパーツは下地にメタルプライマーを吹きつけてから塗装します。
- ご注意: エッチングパーツは大変薄く、手などを切り恐れがあります。取扱いには十分注意して下さい。

涂装色表 PAINT REQUIRED カラー番号リスト

■ C|000 GSI CREOS Mr.COLOR ■ 00-000 ACRYLICOS VALLEJO ■ FS00000 联邦色号

C 1 亮光白 Light white	C 34 光泽天蓝 Brilliant sky blue	C 73 飞机灰色 Aircraft grey
C 3 亮光红 Light red	C 35 光泽明灰 Brilliant grey	C 79 亮红色 Shine Red
C 4 亮光黄 Light yellow	C 43 木棕色 Wood brown	C 92 半光泽黑 Semi-gloss black
C 8 亮光银 Light silver	C 45 帆布色 Sail color	C 117 RLM76浅蓝 RLM76 pale blue
C 9 亮光金 Light gold	C 47 透明红 Clear red	C 135 俄国绿(1) Russian Green(1)
C 25 暗海灰 Dark grey sea	C 60 RLM02灰色 RLM02 grey	C 136 俄国绿(2) Russian Green(2)
C 28 黑铁色 Steel	C 61 烧铁色 Burnt iron	C 137 消光轮胎黑色 Dull tire black
C 33 哑光黑 Matt black	C 72 雾蓝色 Intermediate blue	C 138 透明绿 Transparent green
C 301 FS36081深灰色 FS36081 dark grey	C 324 半光浅灰色 Light grey	
C 305 FS36118深灰色 FS36118 dark grey	C 325 FS26440灰色 FS26440 gray	
C 306 FS36270灰色 FS36270 gray	C 338 FS36495浅灰色 FS36495 light grey	
C 308 FS36375浅灰色 FS36375 light grey	SM 03 超级熟铁色 Super wrought iron	
C 311 FS36622灰色 FS36622 gray	SM 05 超级钛金属色 Titanium color	
C 313 FS33531沙黄色 FS33531 yellow	SM 08 特效电镀银色 Special plating silver	
C 319 浅松绿色 Light green		
C 323 亮光浅蓝色 Light blue		

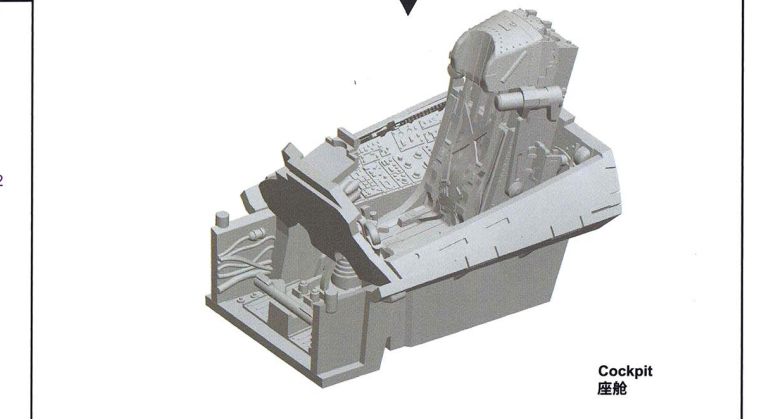
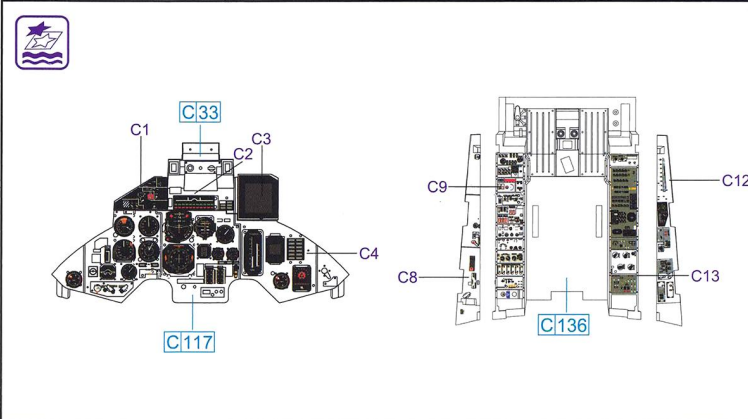
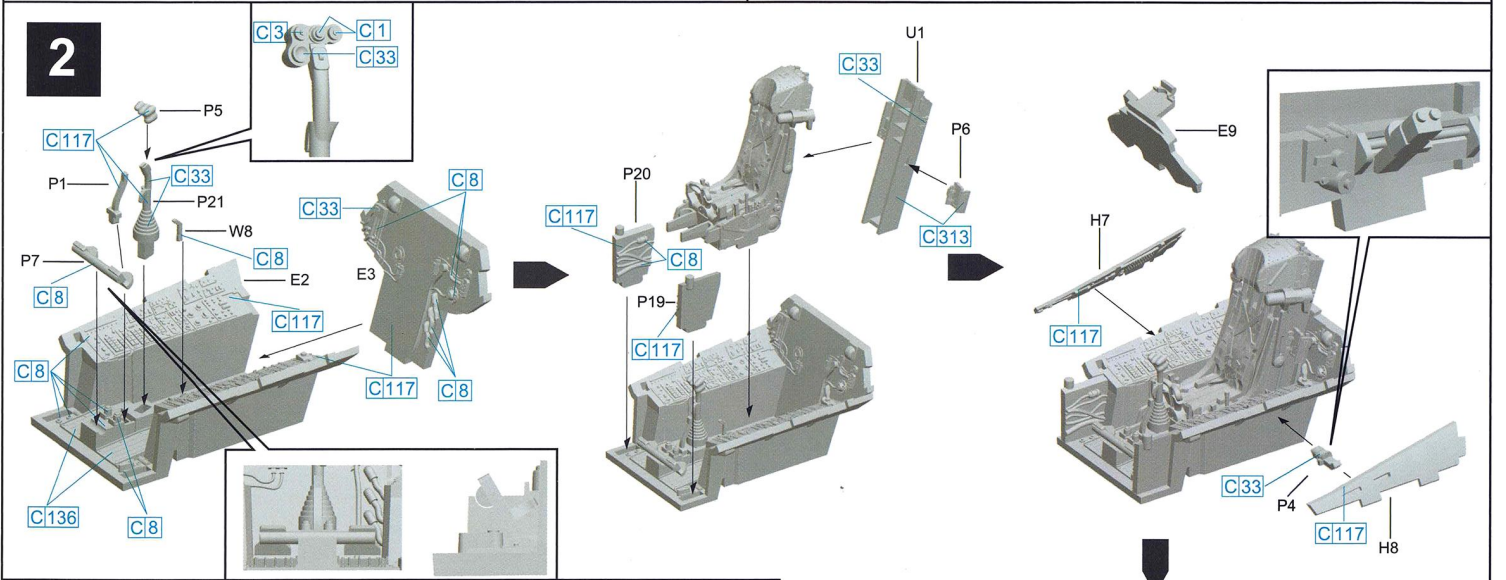
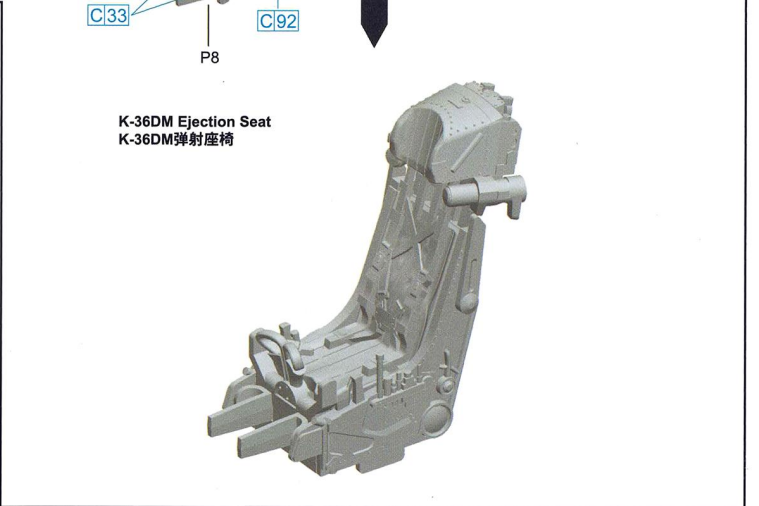
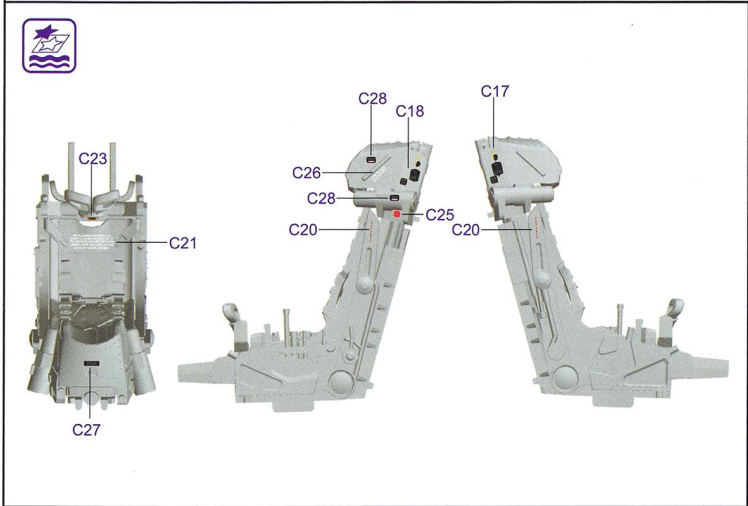
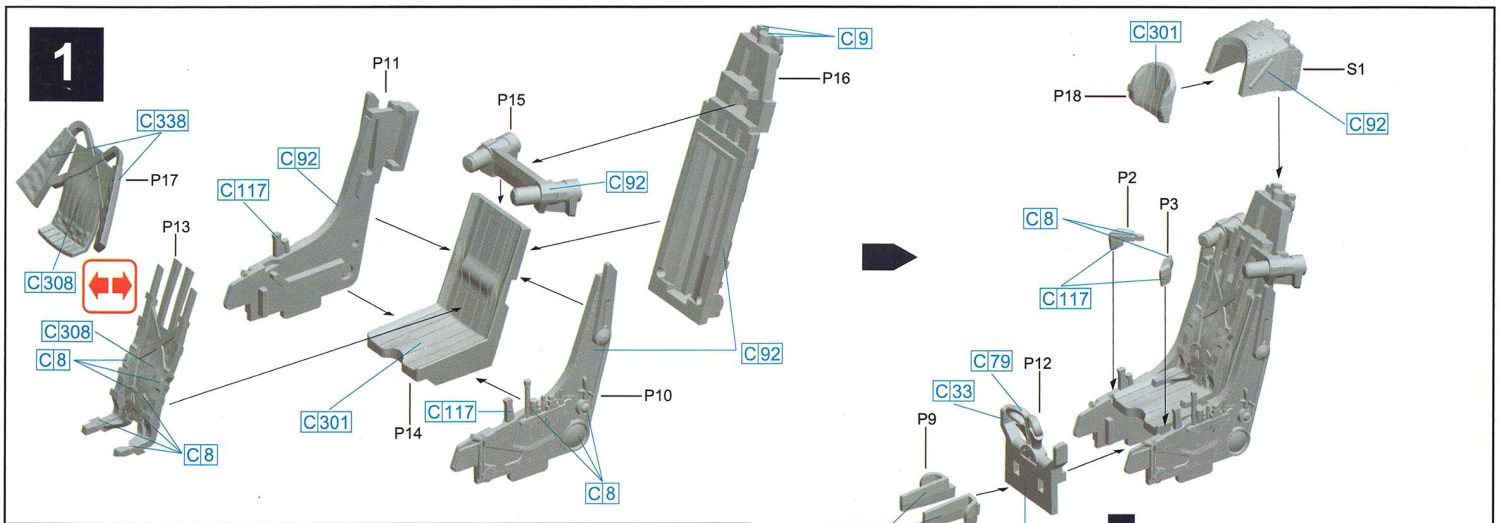

3

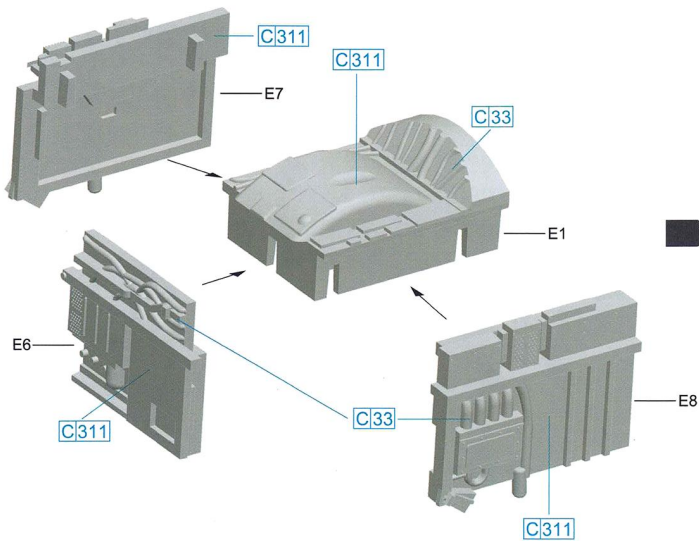
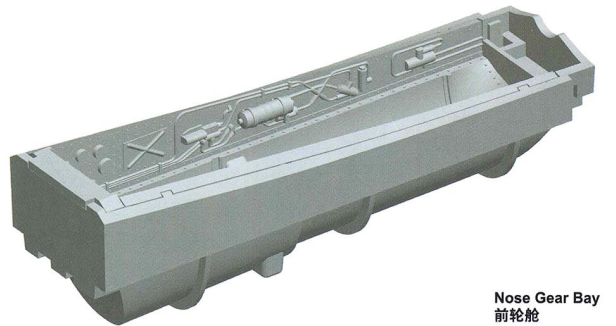
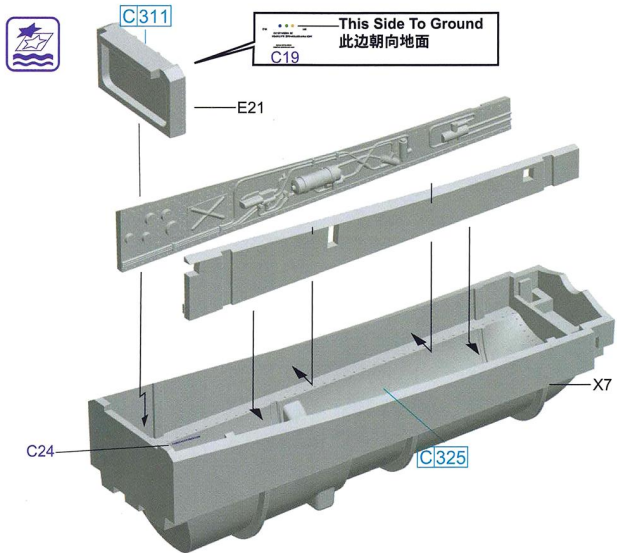
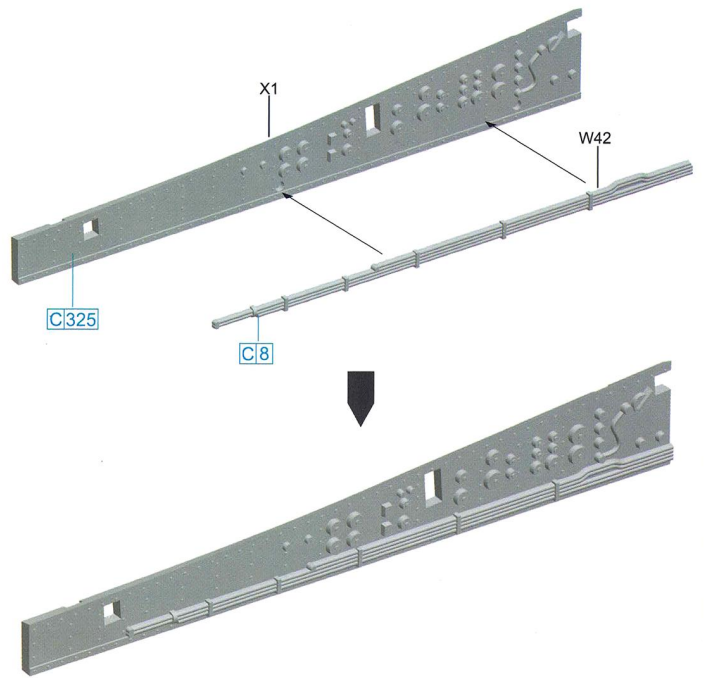
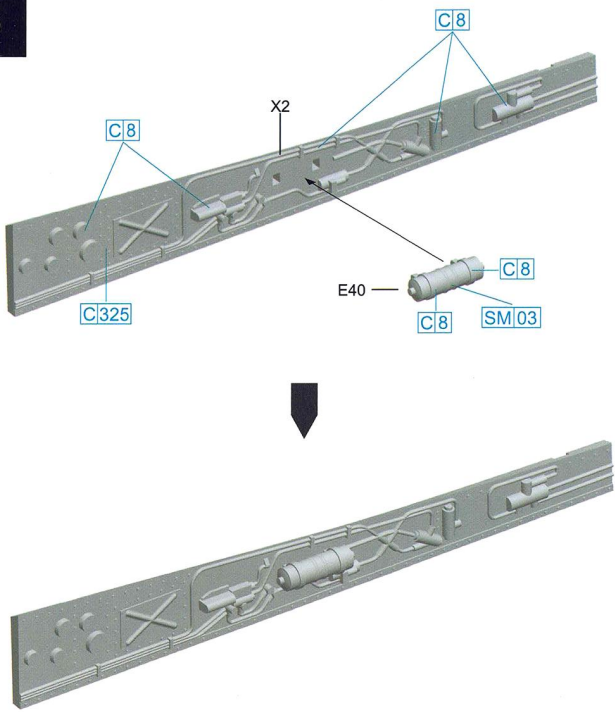

N001 Radar Equipment Box
N001 雷达维护设备



! If Radome Is Not Opened You Can Skip This Step
如果雷达罩不打开可跳过此步骤

5

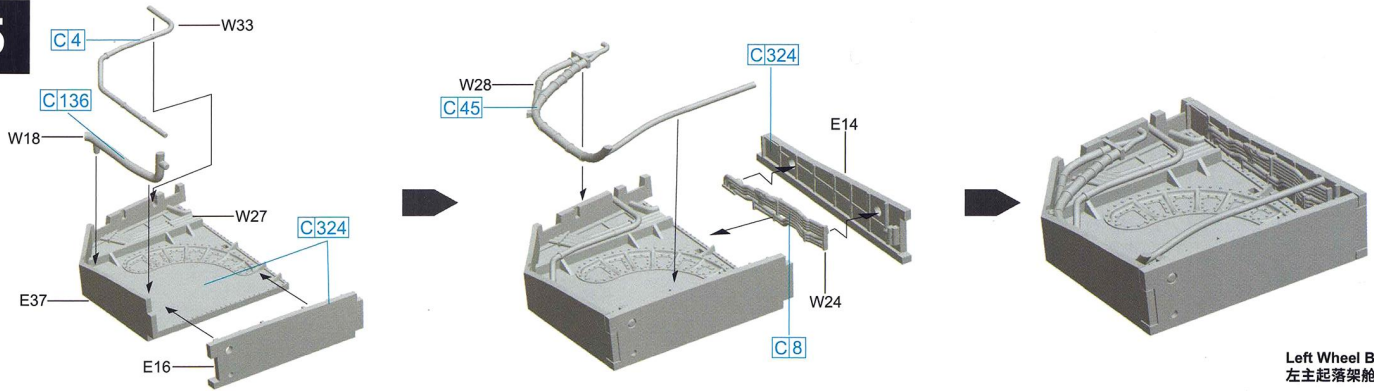

Left Wheel Bay
左主起落架舱

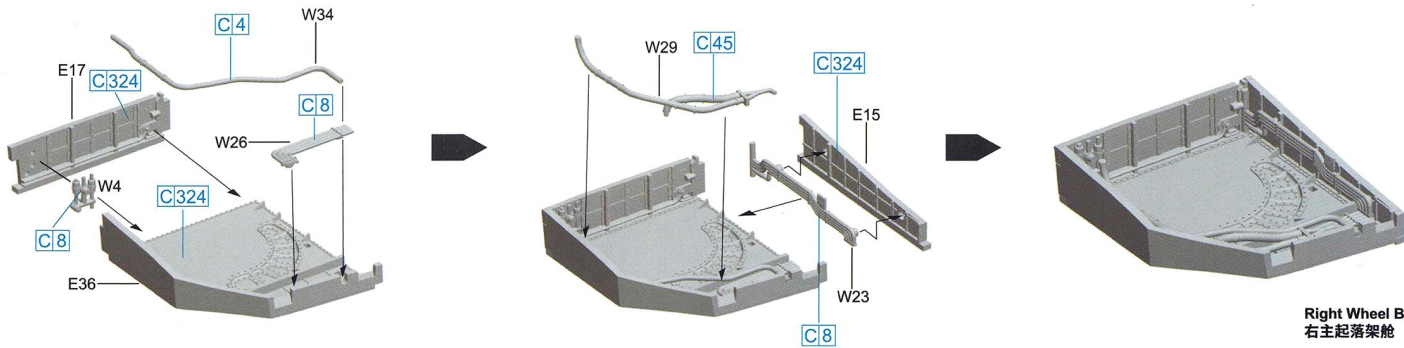

Right Wheel Bay
右主起落架舱

5

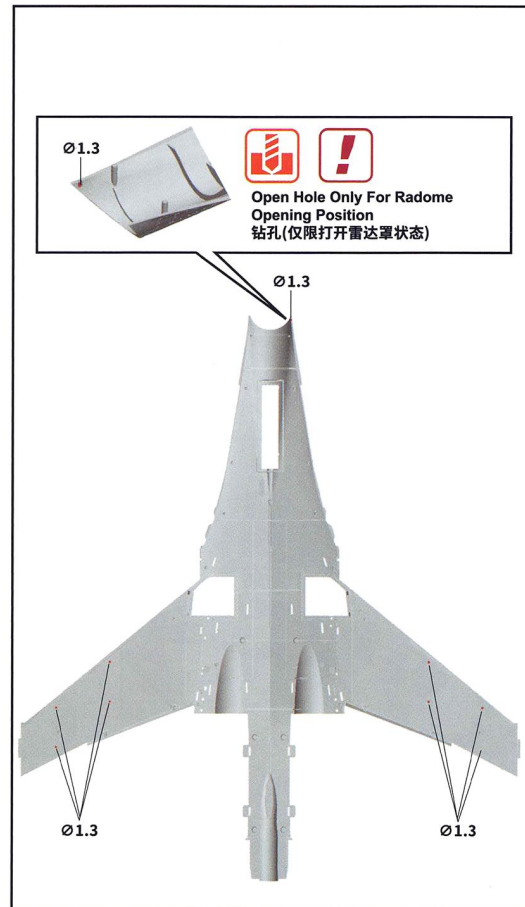
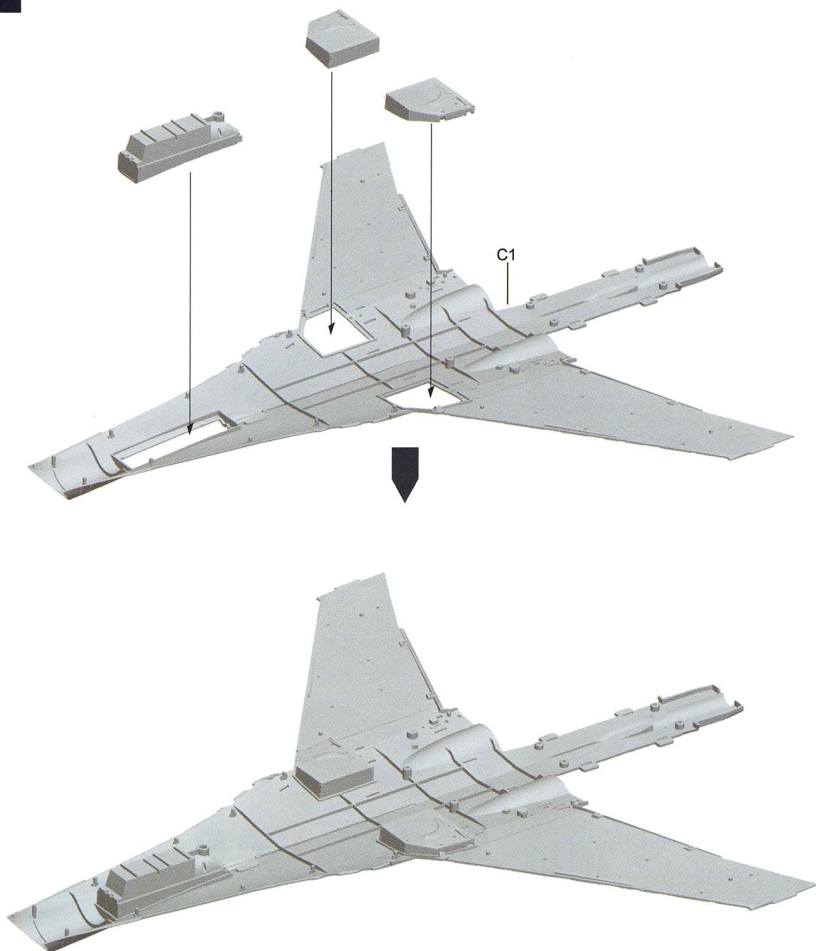

6

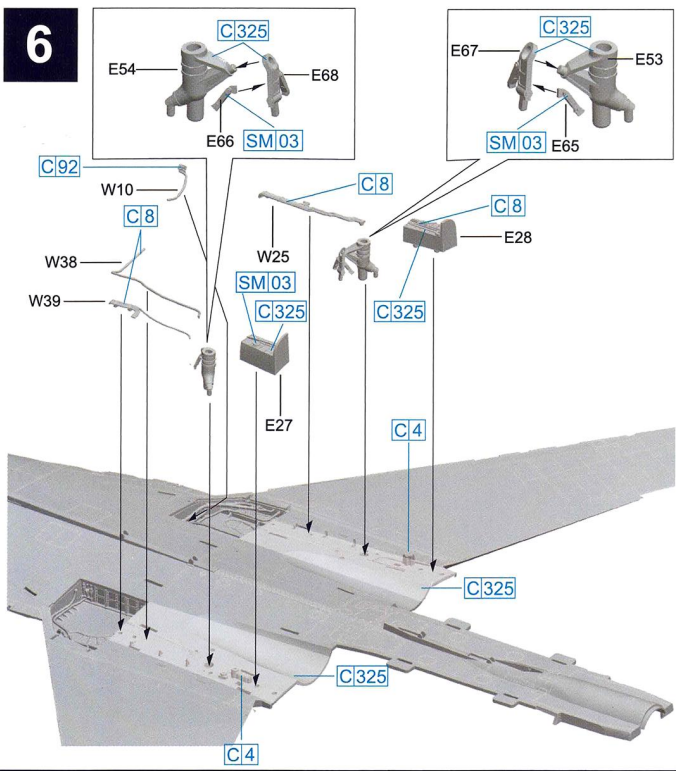

! Skip This Step If Close Gear Bays For In Flight Position
如果制作飞行状态则跳过此步骤

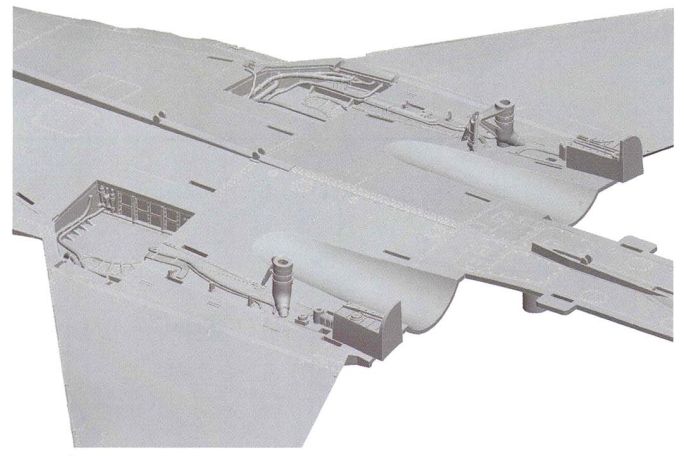

7

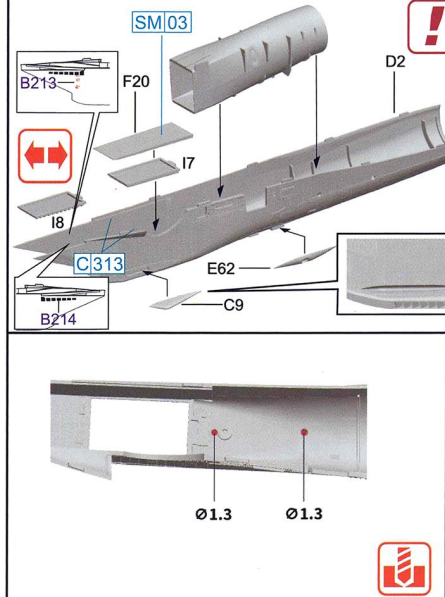
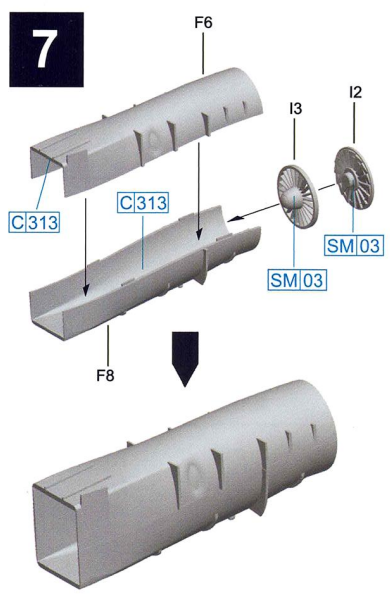

! I7 For Parking Position
I7用于驻机状态
I8 For Inflight Position
I8用于飞行状态

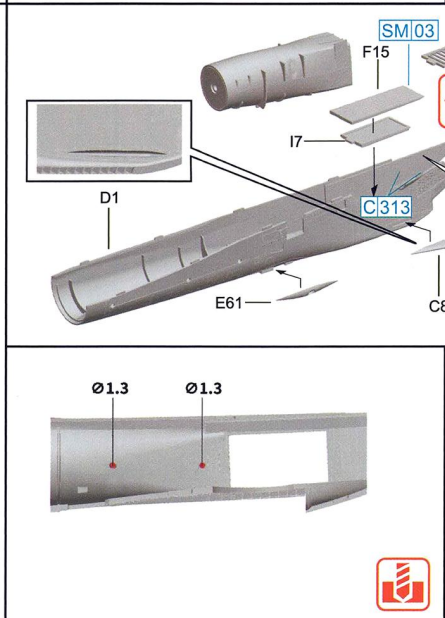
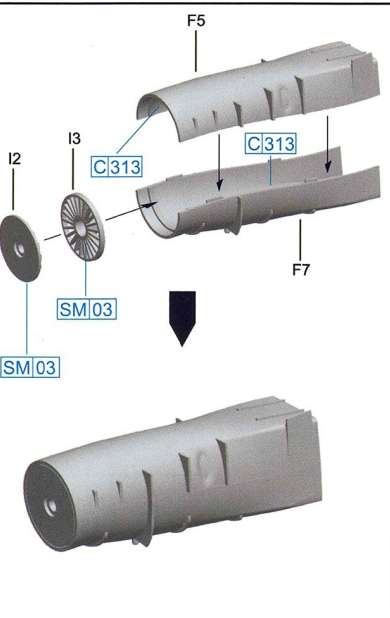
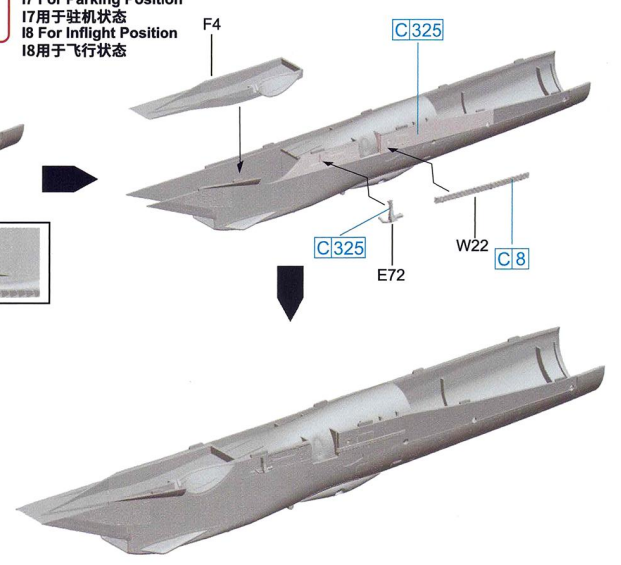

! I7 For Parking Position
I7用于驻机状态
I8 For Inflight Position
I8用于飞行状态

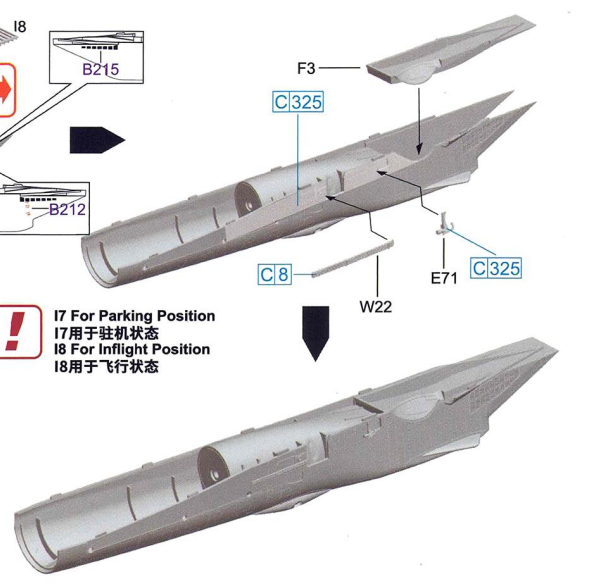

8

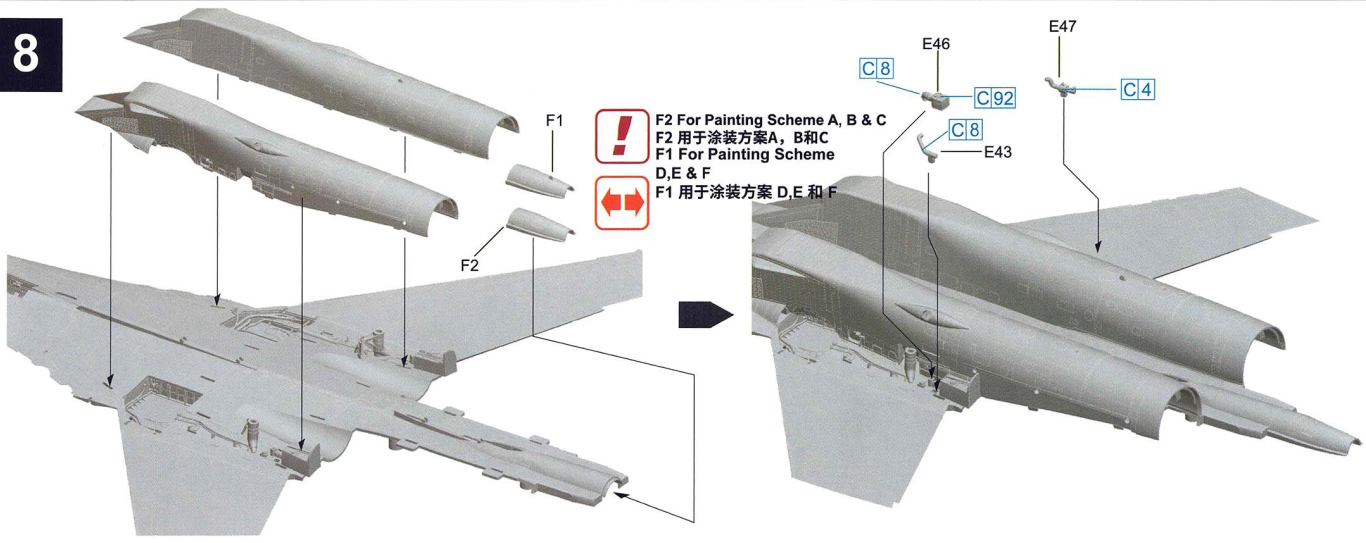

! F2 For Painting Scheme A, B & C
 F2 用于涂装方案A, B和C
↔ F1 For Painting Scheme D, E & F
 F1 用于涂装方案D, E和F

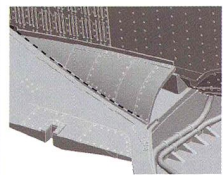

! Pay Attention To The Intake Postion Against Lower Fuselage
 注意进气道与下机身的相对配位位置

9

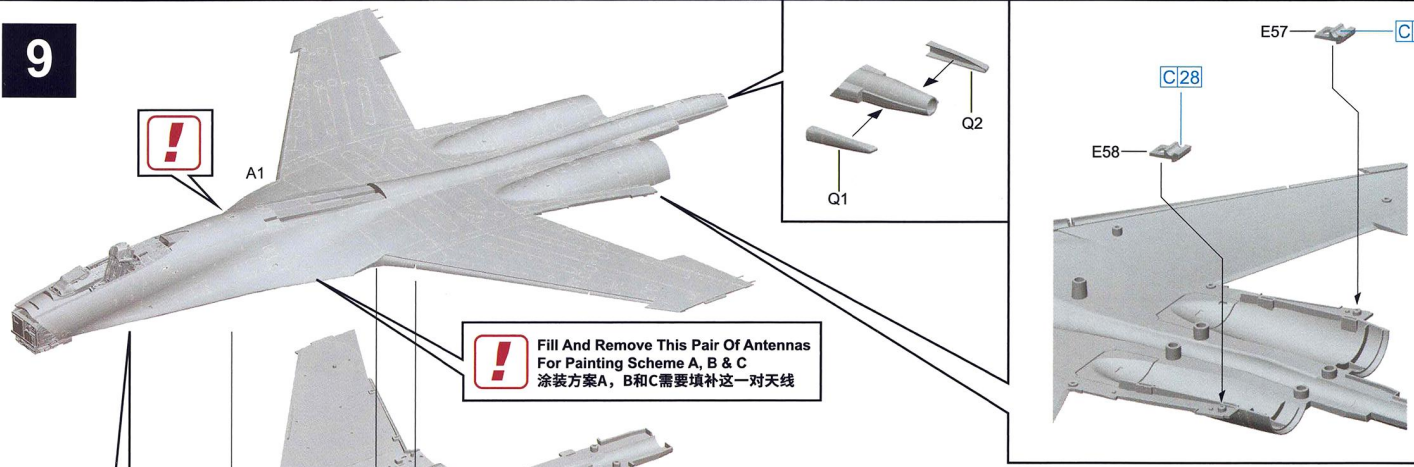

! Fill And Remove This Pair Of Antennas For Painting Scheme A, B & C
 涂装方案A, B和C需要填补这一对天线

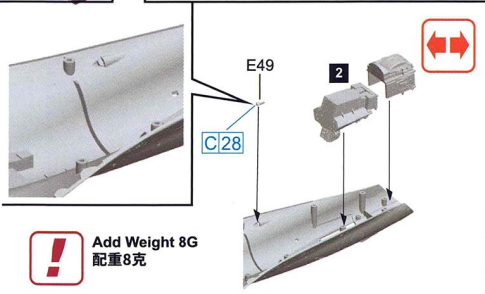

! Add Weight 8G
 配重8克

10

! **✂**
Cut The Hinges To Close Radome
切去定位插栓用于关闭雷达罩

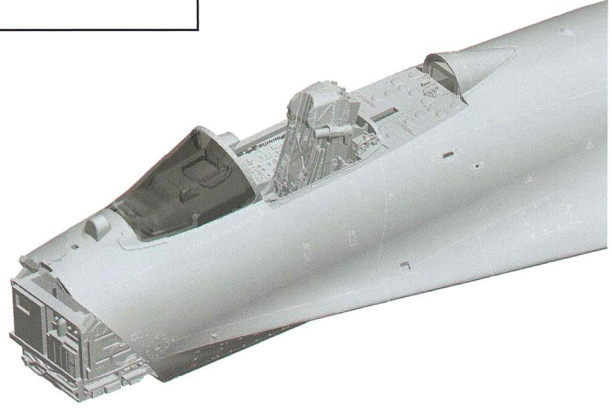
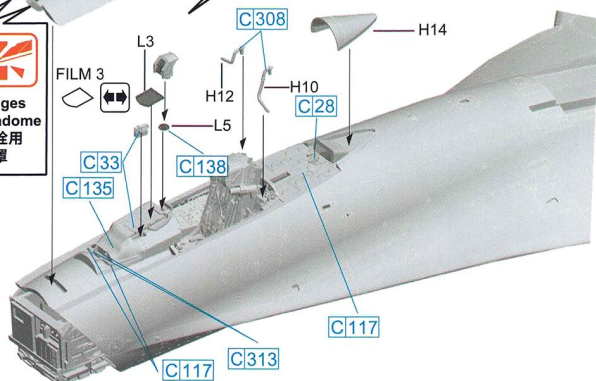
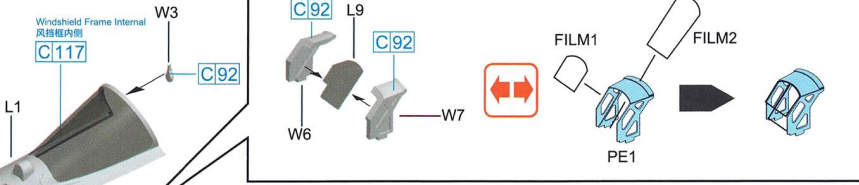

11

! Some Airframes Have Reinforcement Plates,
Please Refer To Your Reference
某些机体装有补强板请自行参考资料使用

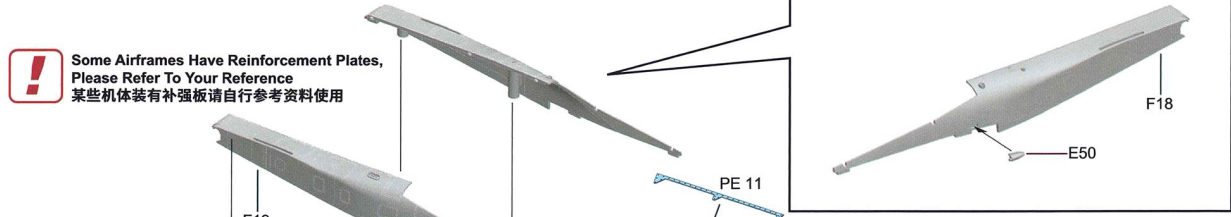

! Downwards When Parking
驻机状态时朝下

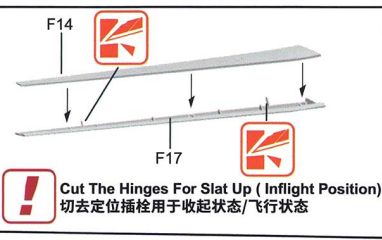
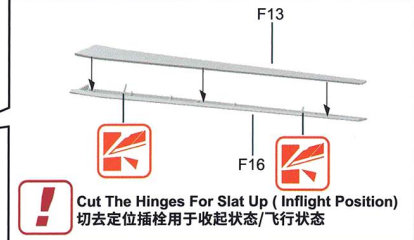

! Downwards When Parking
驻机状态时朝下



 **Open Hole Only For Radome Opening Status**
 钻孔 (仅限打开雷达罩状态)

12 **Only For Radome Opening Position**
 仅限打开雷达罩状态

Left Side View
 左侧视

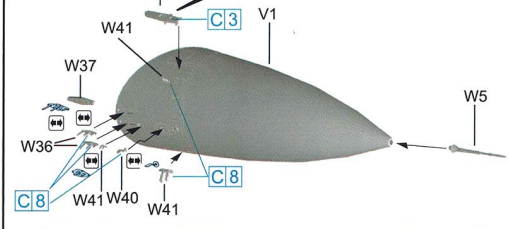
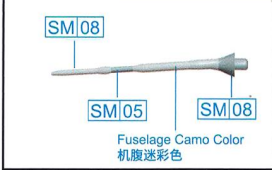

Pitot Tube Has 3 Degree Up Against radome center line
 空速管与雷达罩中心线呈3度上翘夹角



Radome
 雷达罩

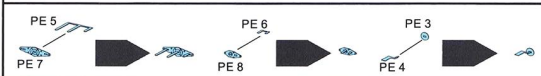

Please Sand Off The Injection Gate
 Trace On Part N1 Carefully. Do NOT Cut!
 请使用砂纸小心打磨N1零件注塑水口, 切勿切割!

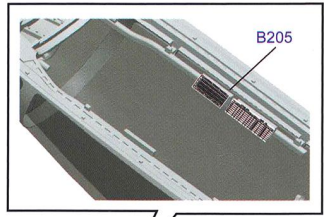
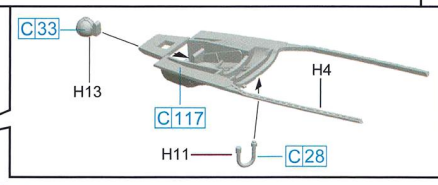
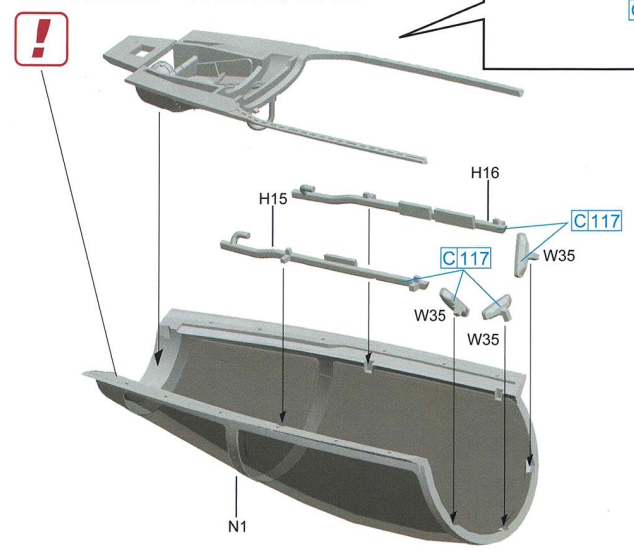

Please Cut Partially
 需要切割

Canopy
 座舱盖

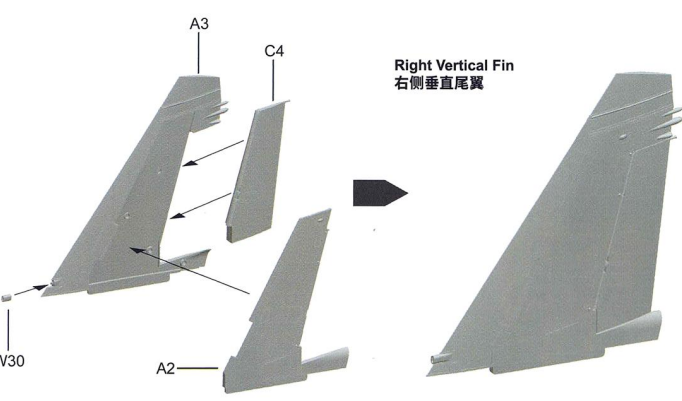

Right Vertical Fin
 右侧垂直尾翼

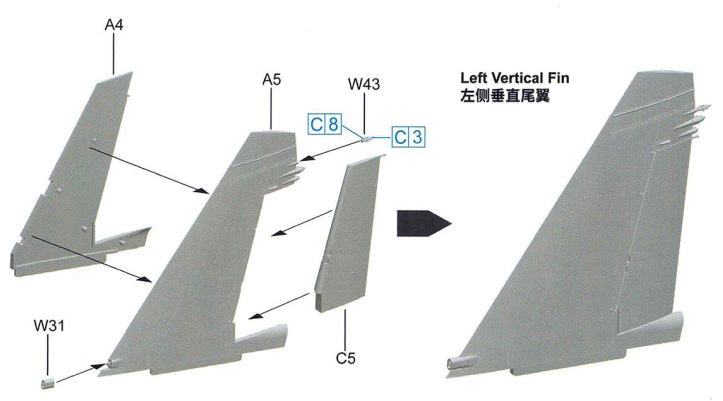

Left Vertical Fin
 左侧垂直尾翼

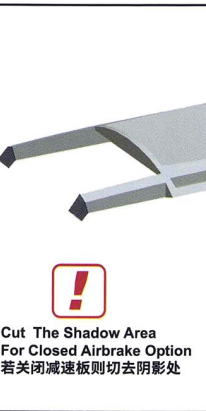

Cut The Shadow Area
 For Closed Airbrake Option
 若关闭减速板则切去阴影处

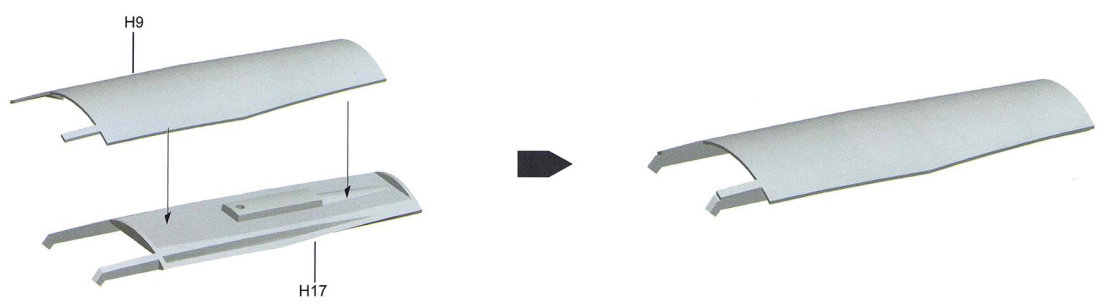

Airbrake
 减速板

12

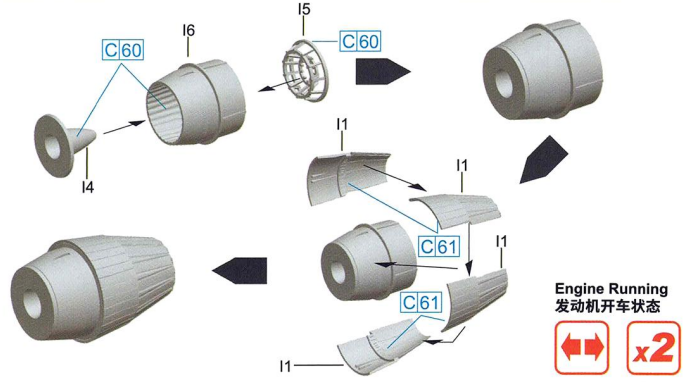
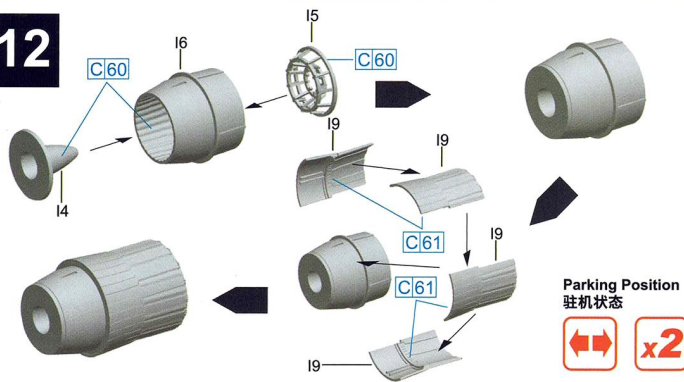

13

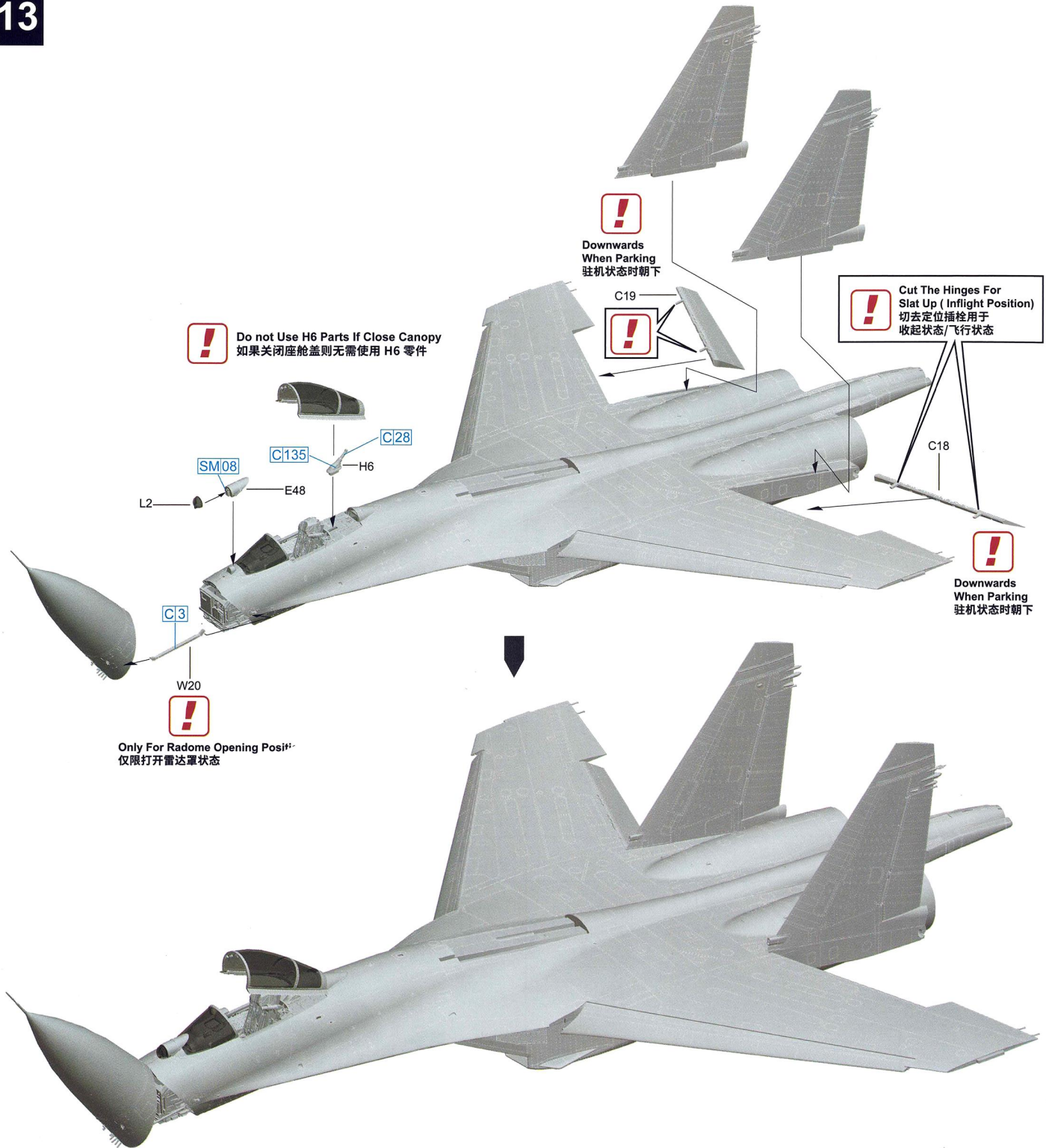

14

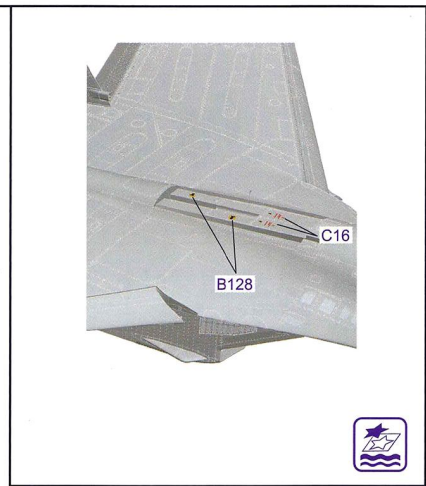
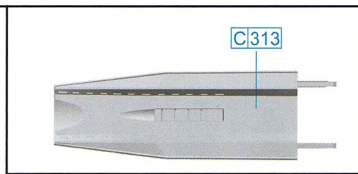
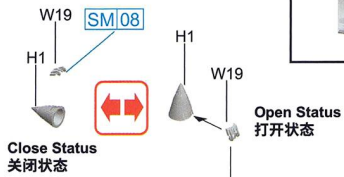

! Some Airframes Have Reinforcement Plates, Please Refer To Your Reference
某些机体装有补强板, 请自行参考资料使用



! Only For Radome Opening Position
仅限打开雷达罩状态

15

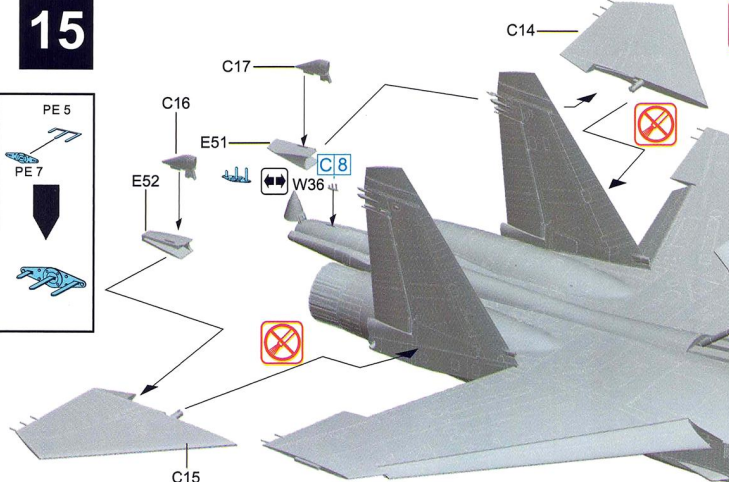

! In Downward Position When Parking
驻机状态时朝下



16

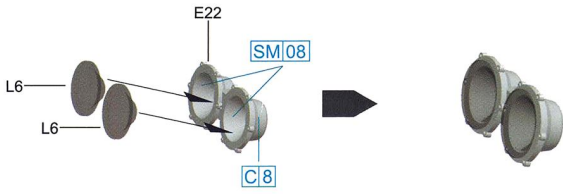

17

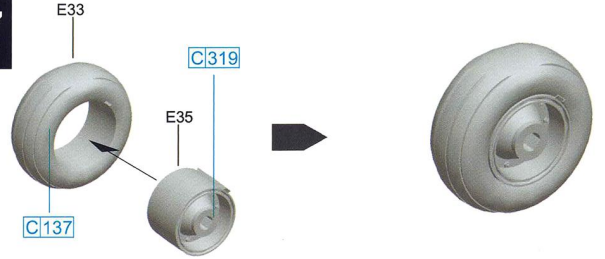

Reduce By 0.5mm For Full Load Status
制作满载状态，液压杆缩短0.5mm

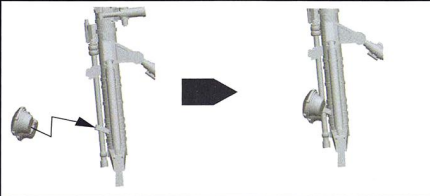

Gently Adjust Angle Of Rods If Necessary
如有需要请轻微调节连接杆角度

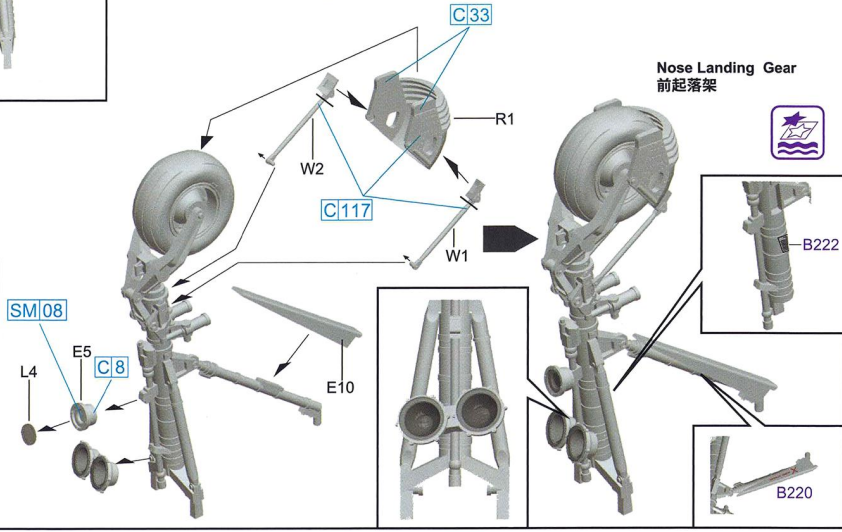
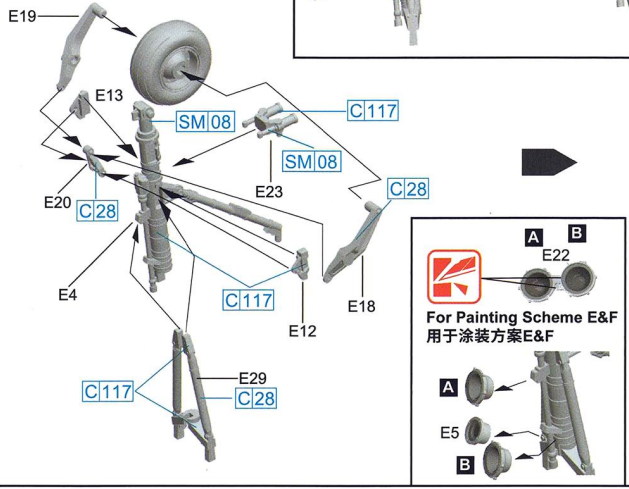

Nose Landing Gear
前起落架

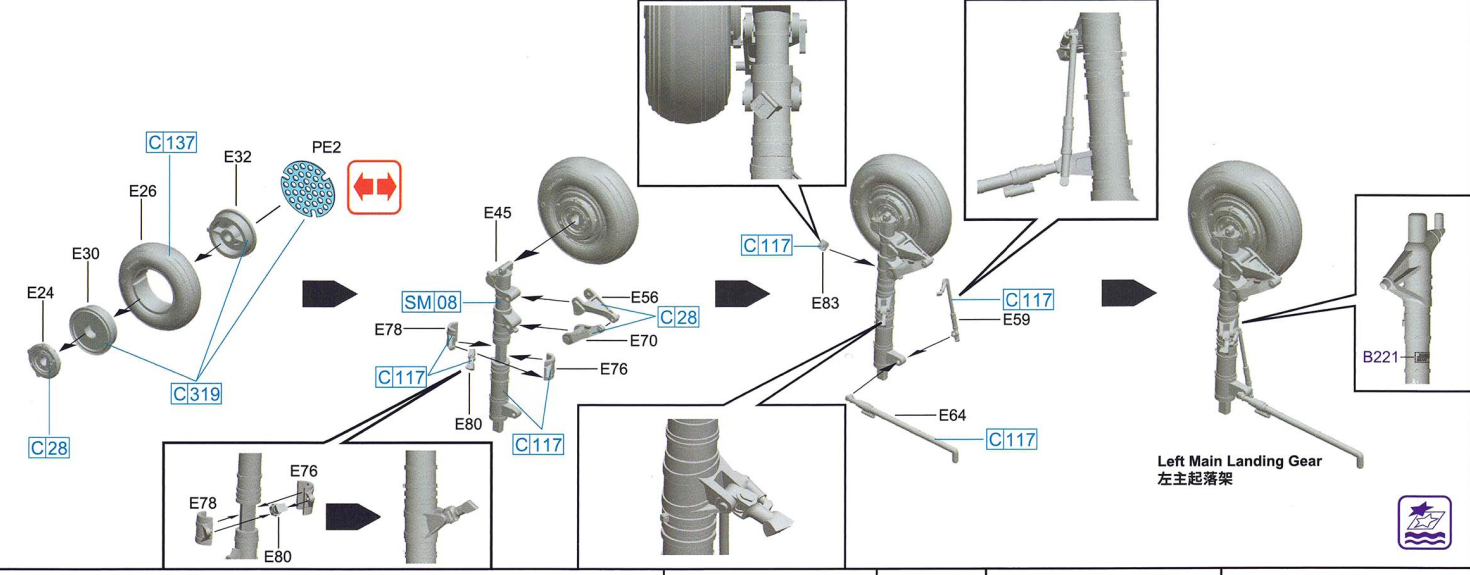

Left Main Landing Gear
左主起落架

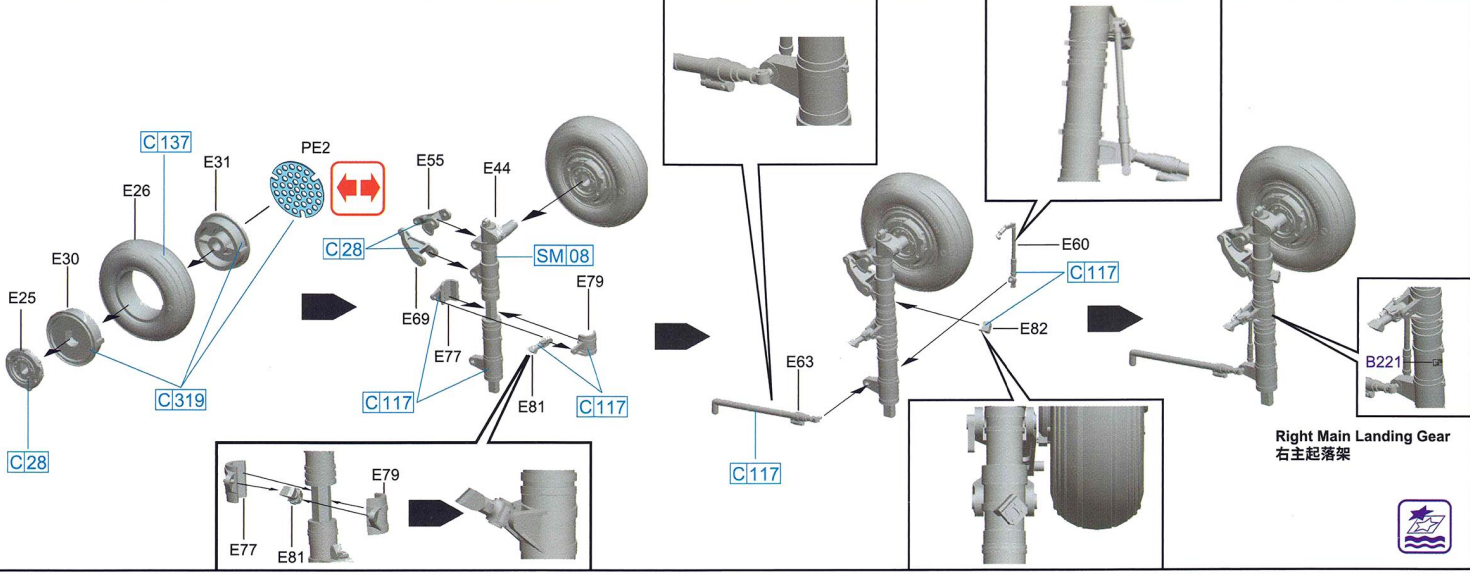

Right Main Landing Gear
右主起落架

18

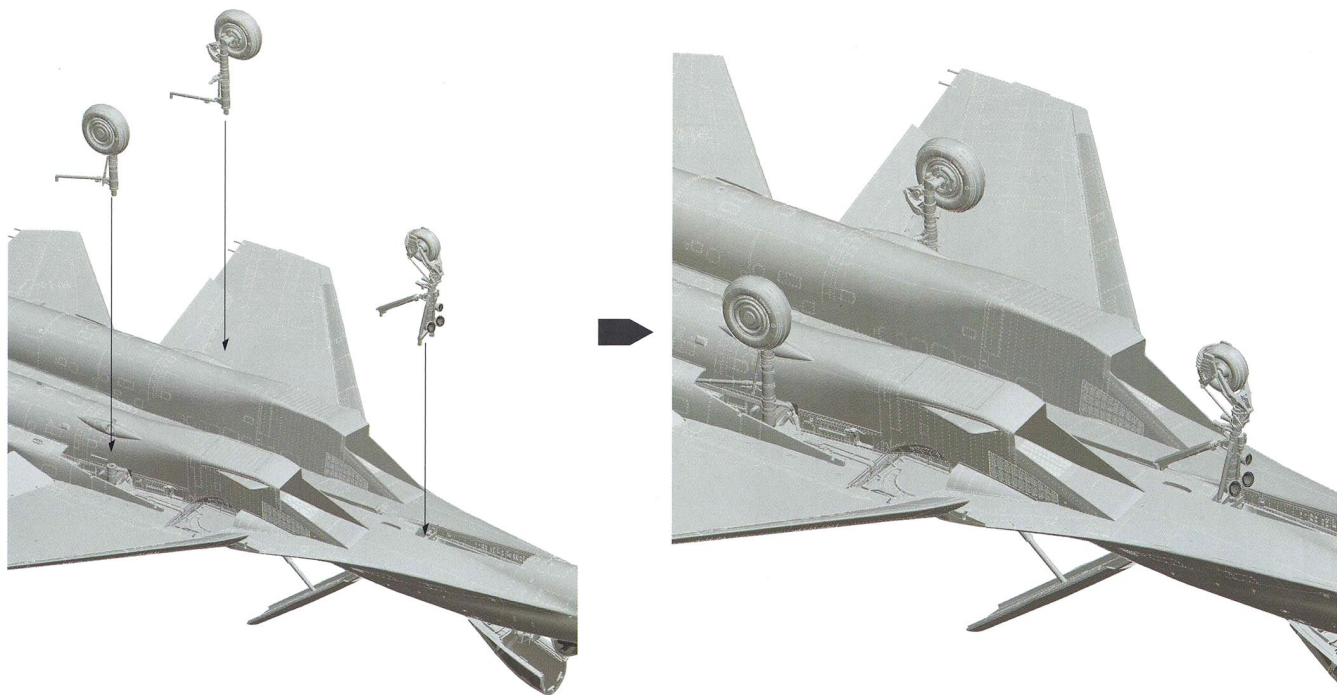

19

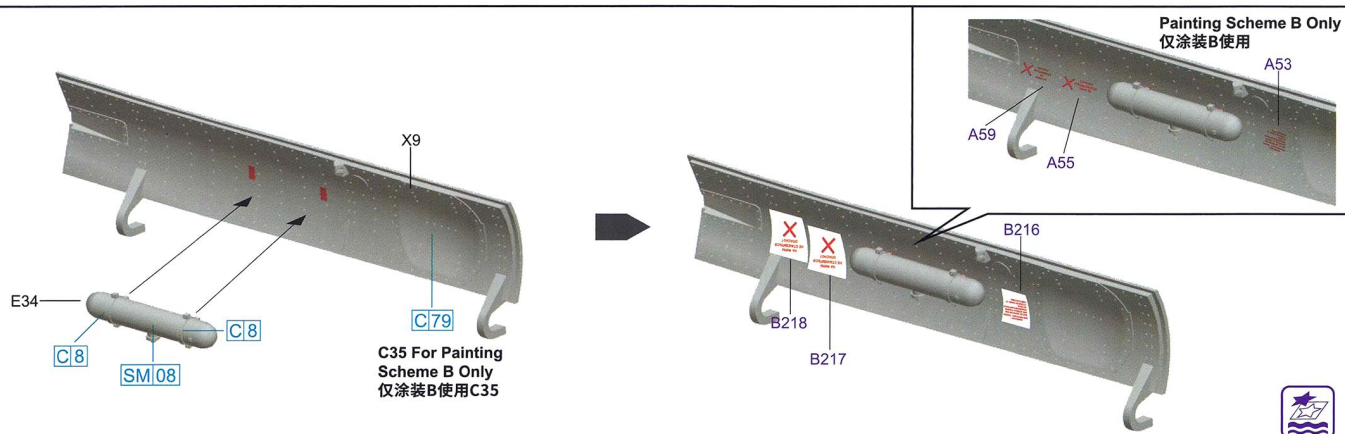

20

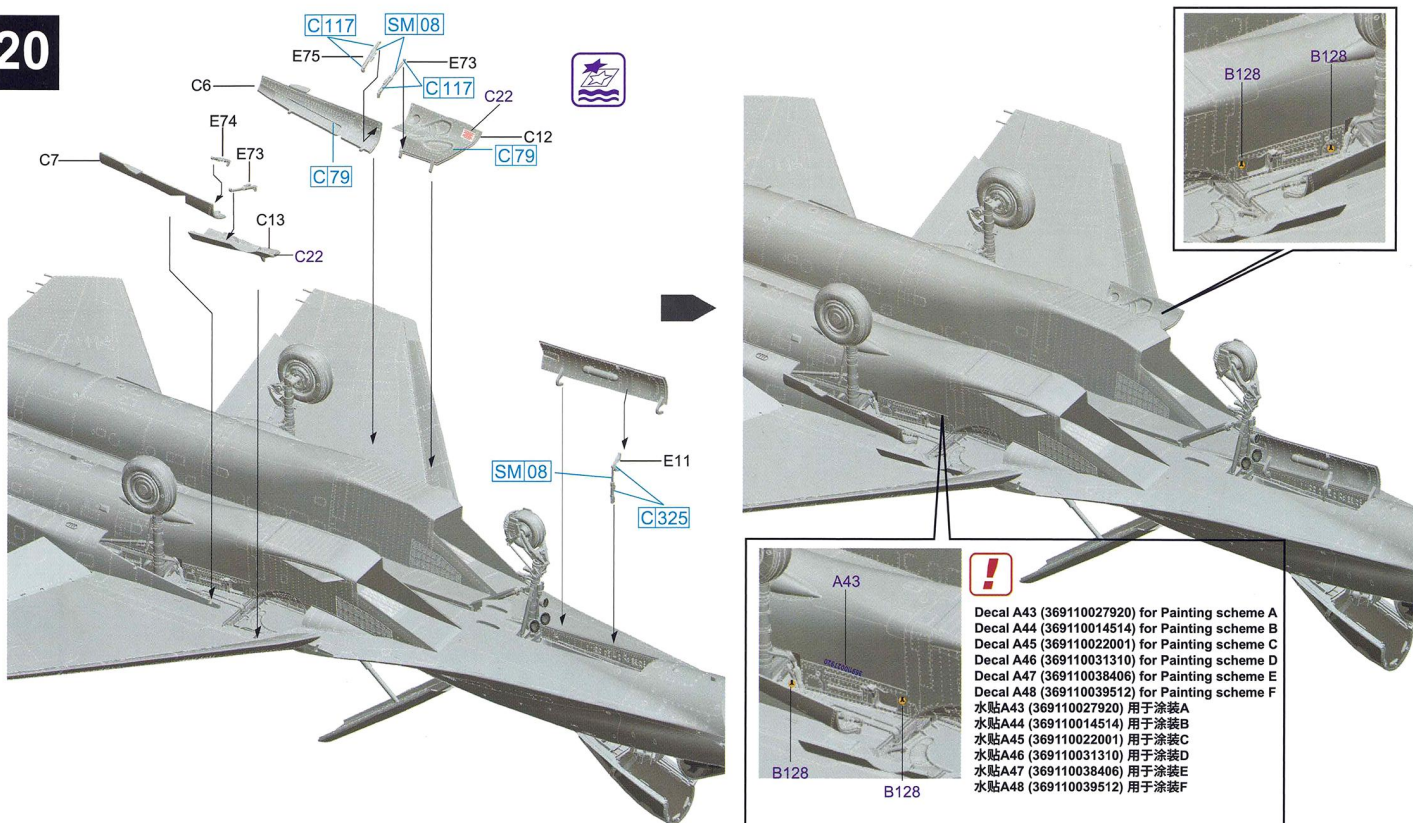

21

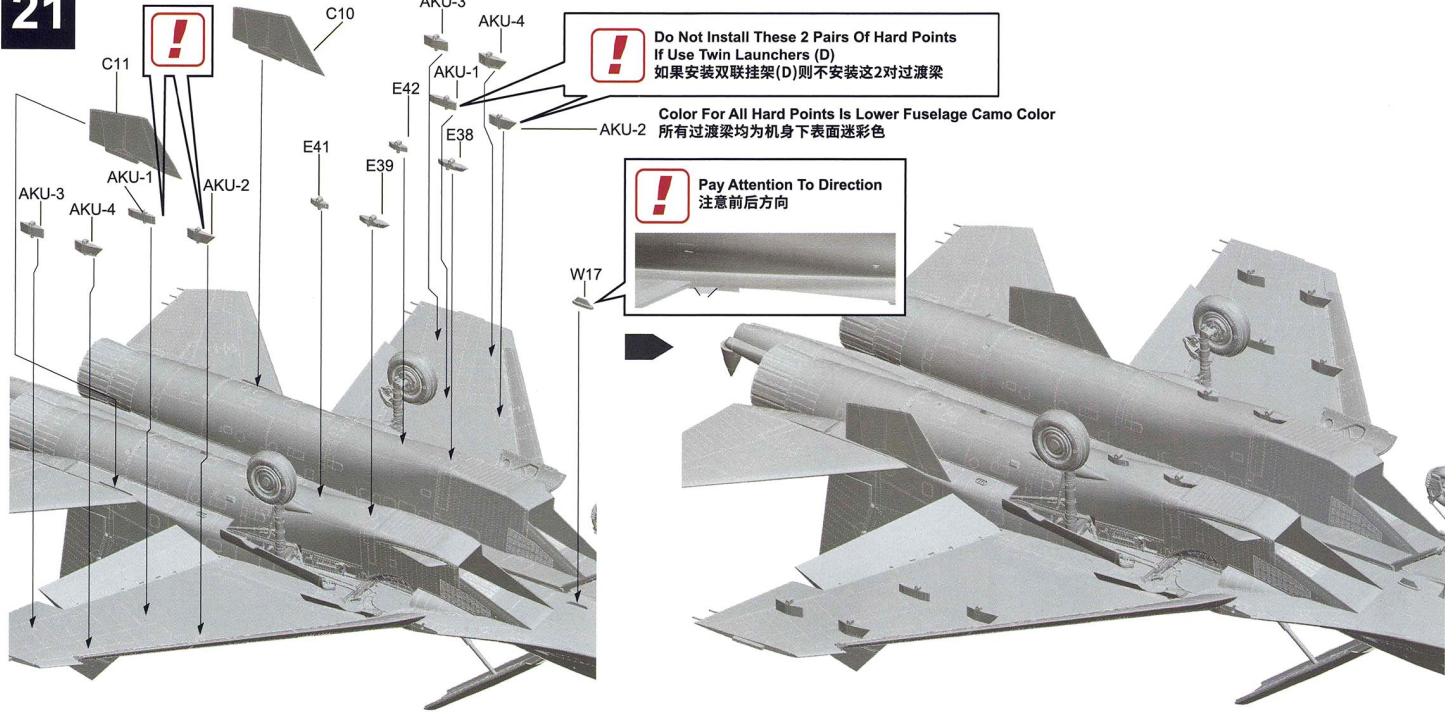

22

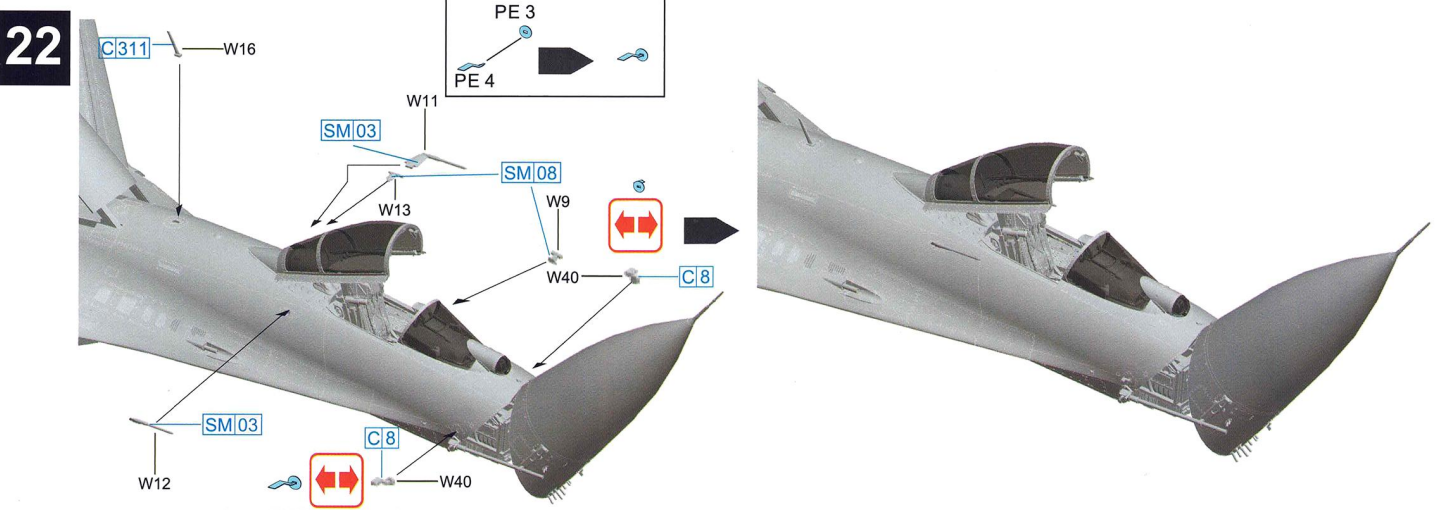

23

Weapon Ordnance
武器挂载

! Cut Some Details On Weapon Surface To Install Pylons Dry Fit Before Gluing
武器表面一些细节需要切除才可安装挂架粘台前请务必假组

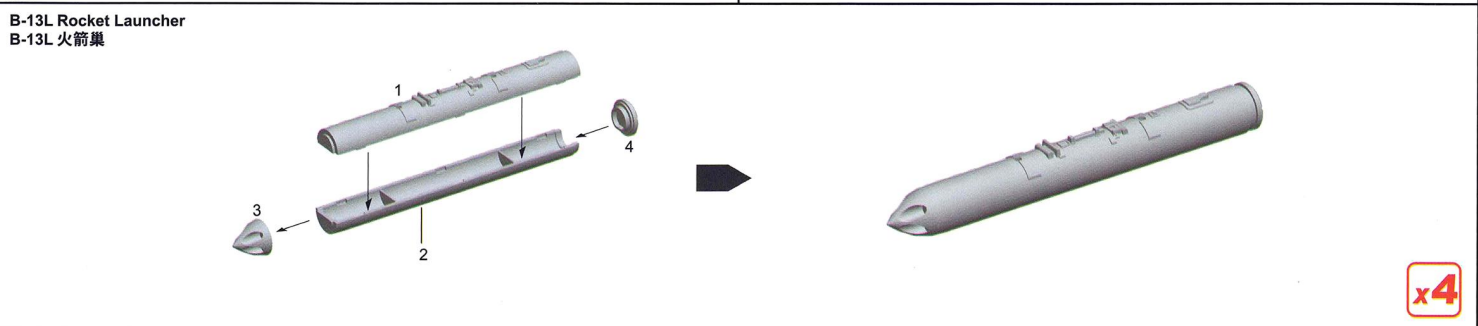
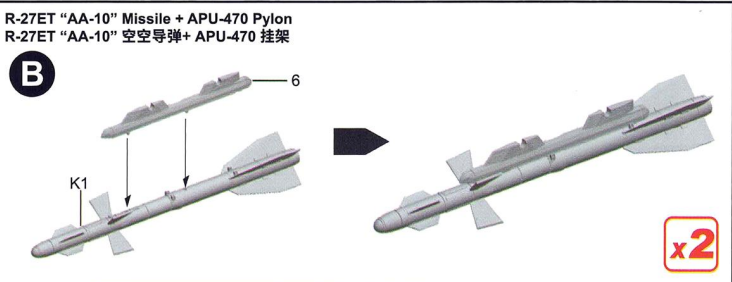
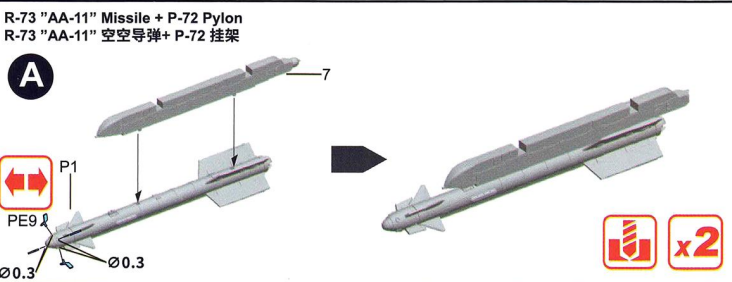

B-13L Launcher + BD3-USK-A Pylon(Single)
B-13L 火箭巢+ BD3-USK-A 挂架 (单发)

C

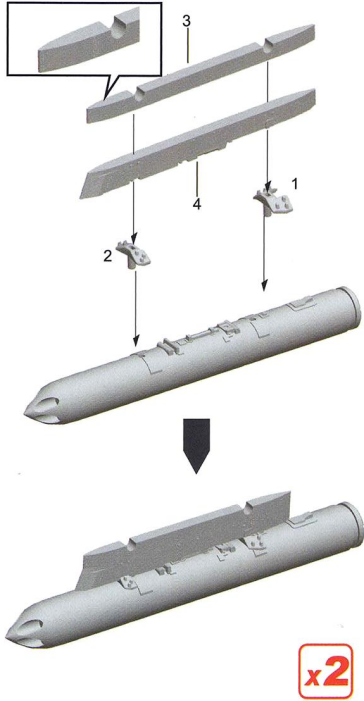

B-13L Launcher + BD3-USK-A Pylon(Twin)
B-13L 火箭巢+ BD3-USK-A 挂架 (双联)

D

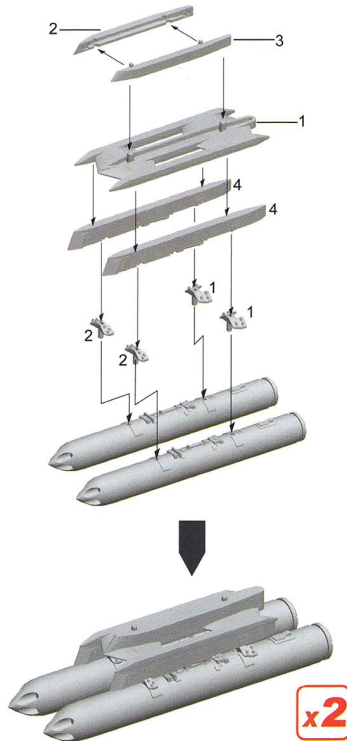

R-27ER "AA-10" Missile + AKU-470 Pylon
R-27ER "AA-10" 空空导弹+ AKU-470 挂架

E

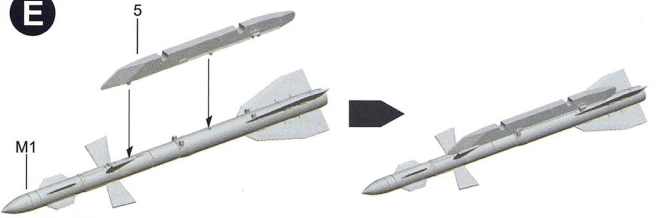

R-73 "AA-11" Missile + Wingtip P-72 Pylon
R-73 "AA-11" 空空导弹+ 翼尖P-72挂架

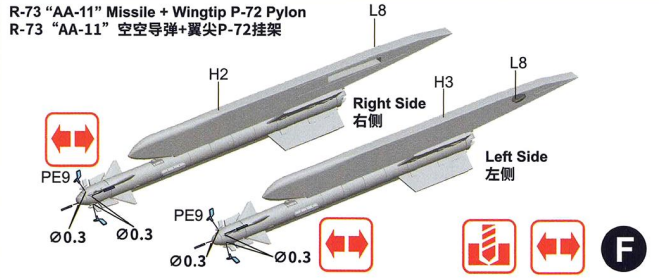

L-005 "Sorbsiya" Ecm Pod
L-005 "吸附" 电子对抗吊舱

Only For Painting
Schemes ABCD
仅用于涂装ABCD

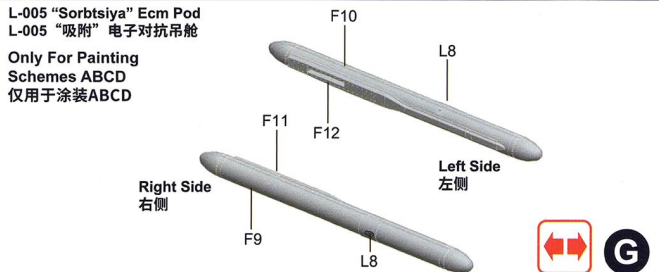

24

Weapon Ordance
挂载方案

All Weapons Are Vertical To Ground From This View
从本视角看所有武器均应垂直于地面



A



B



C



D



E



F



G



P-72 Pylon
P-72 挂架

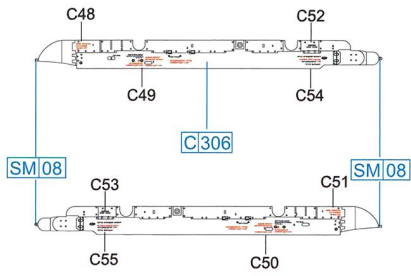

APU-470 Pylon
APU-470 挂架

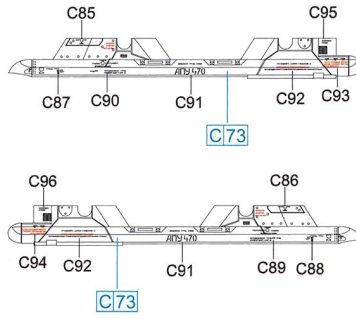

BD3-USK-A Pylon
BD3-USK-A 挂架

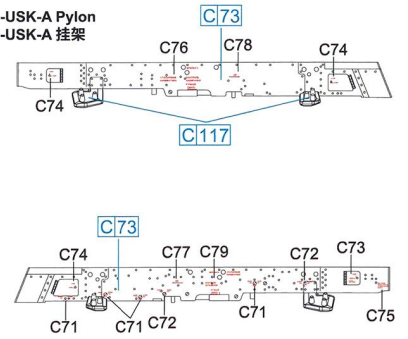

Wingtip P-72 Pylon
翼尖P-72挂架

Left Side
左侧

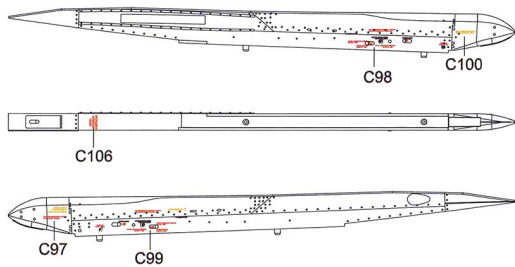

Right Side
右侧

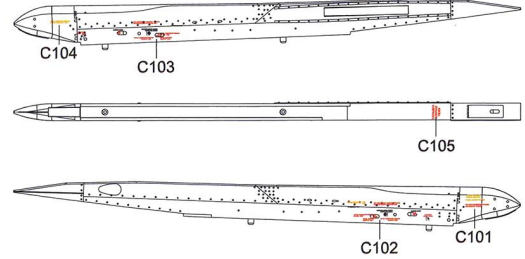

AKU-470 Pylon
AKU-470 挂架

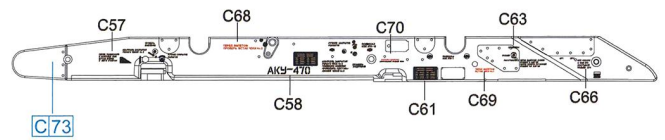
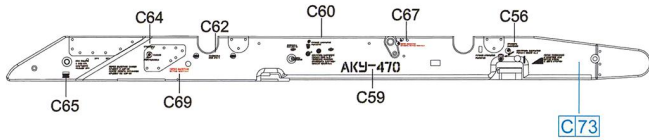

R-73 "AA-11" Missile
R-73 "AA-11" 空空导弹

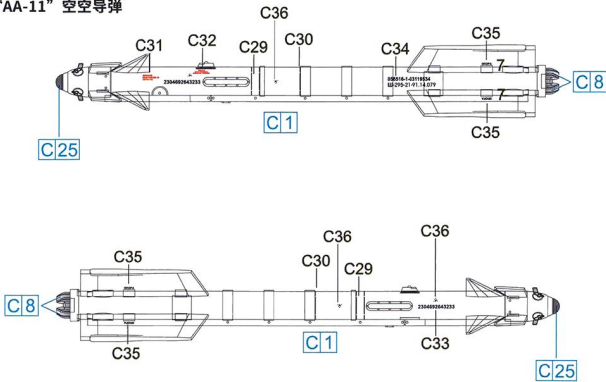

R-27ET "AA-10" Missile
R-27ET "AA-10" 空空导弹

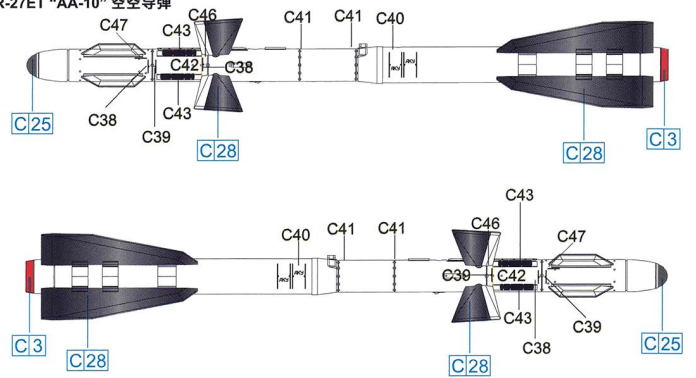

R-27ER "AA-10" Missile
R-27ER "AA-10" 空空导弹

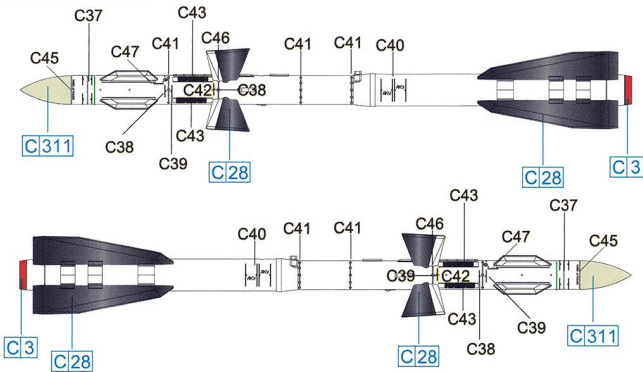

B-13L Launcher
B-13L 火箭巢

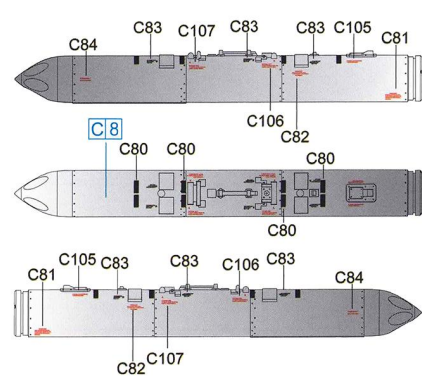

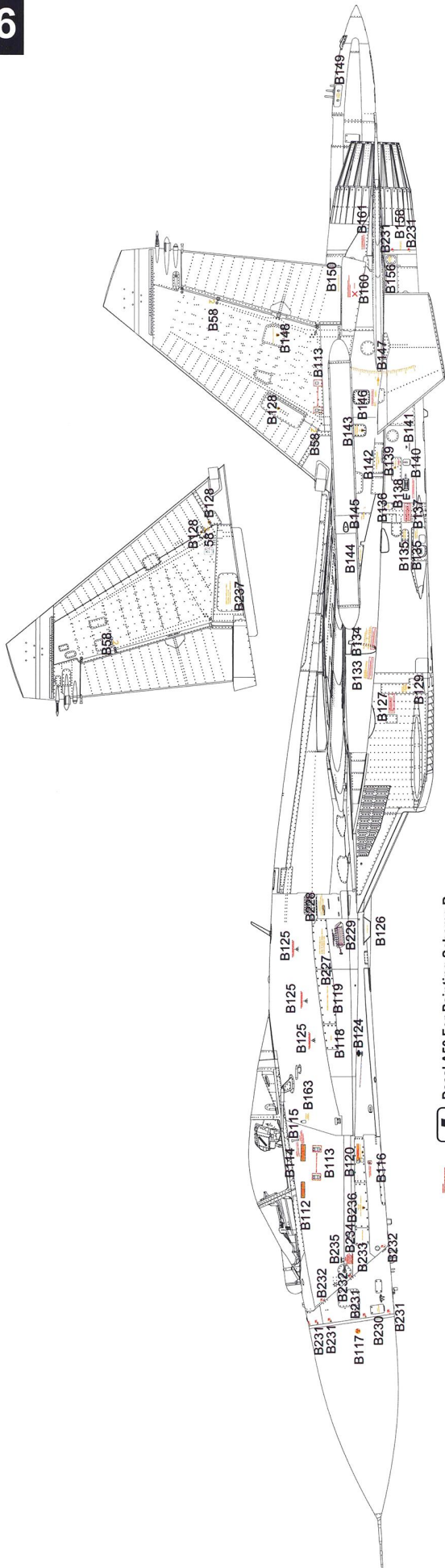

-  B115
-  B113
-  B113
-  B113
-  B113
-  B113
-  B113
-  B113
-  B113
-  B113
-  B113
-  B113
-  B113
-  B113
-  B113
-  B113
-  B113
-  B113
-  B113
-  B113
-  B113
-  B113
-  B113
-  B113
-  B113
-  B113
-  B113
-  B113
-  B113
-  B113
-  B113
-  B113
-  B113
-  B113
-  B113

Decal A50 For Painting Scheme B
 涂装B使用水贴A50

Decal A49 For Painting Scheme B
 涂装B使用水贴A49

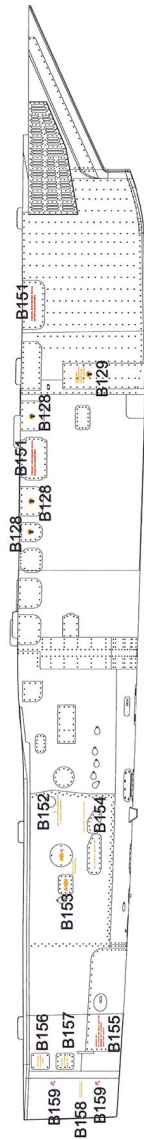
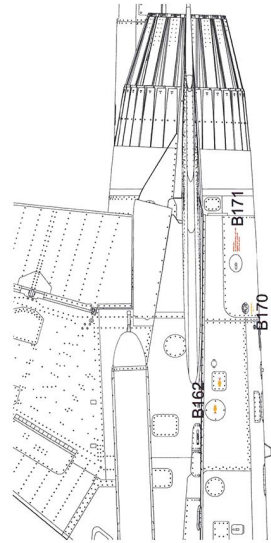

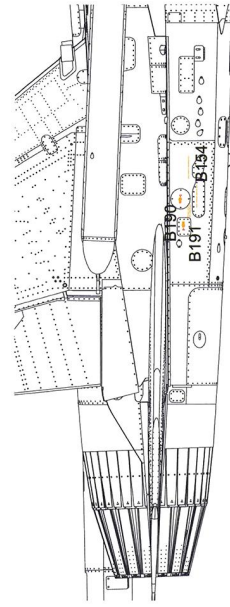
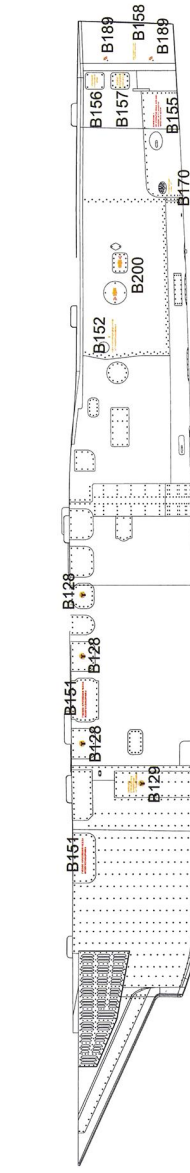
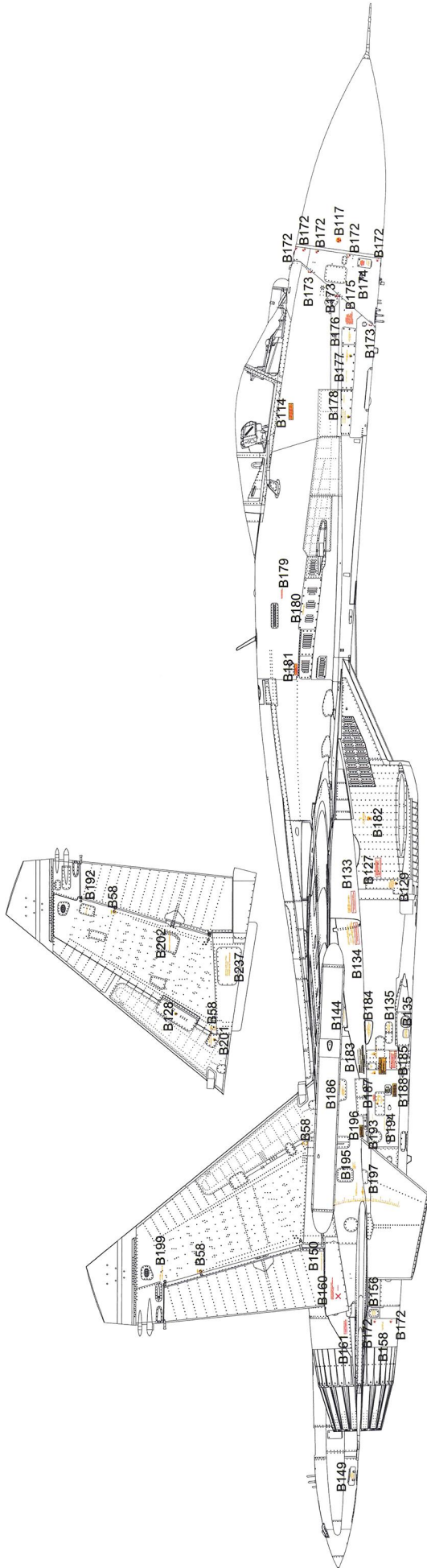

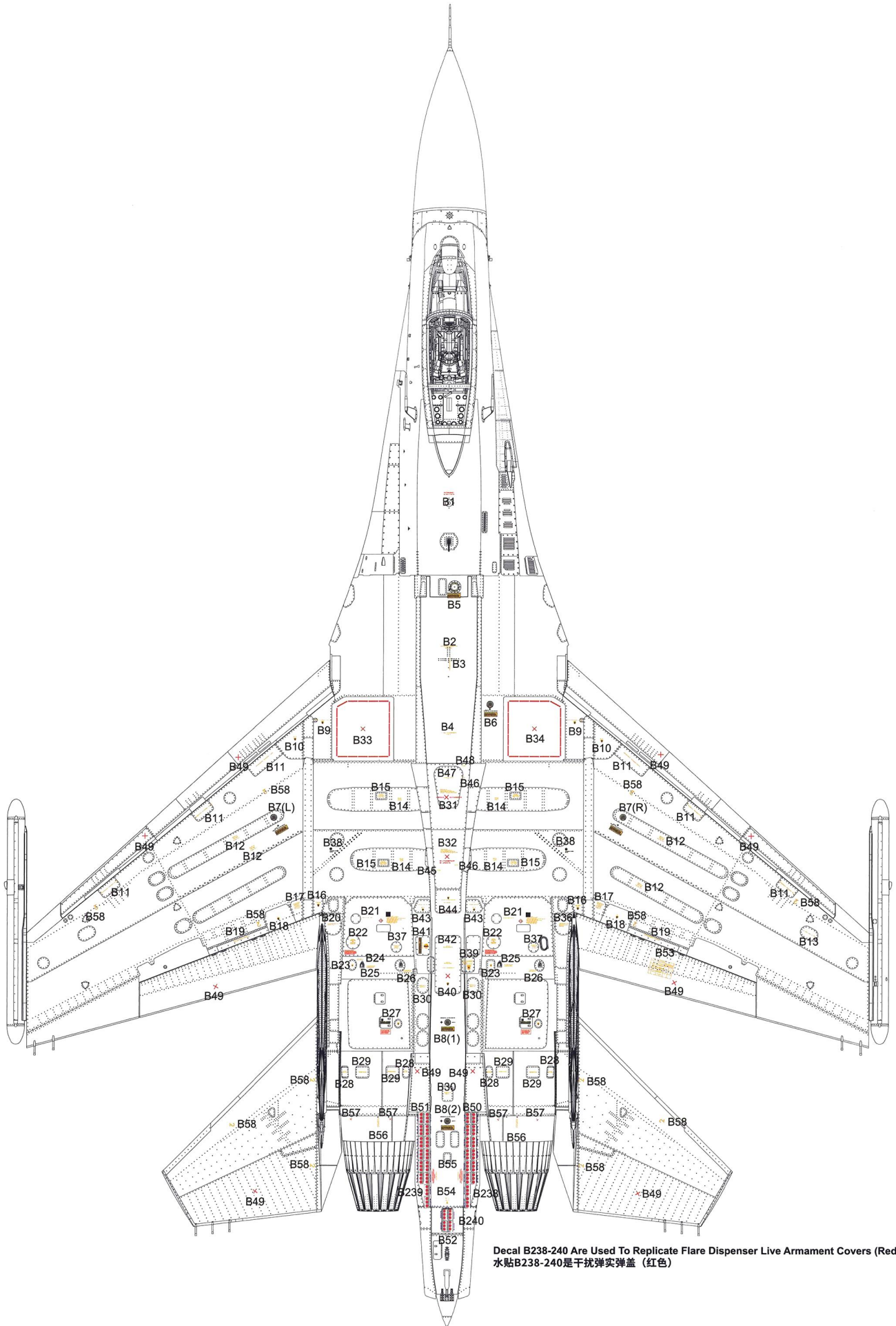

Decal B238-240 Are Used To Replicate Flare Dispenser Live Armament Covers (Red)
水贴B238-240是干扰弹实弹盖 (红色)

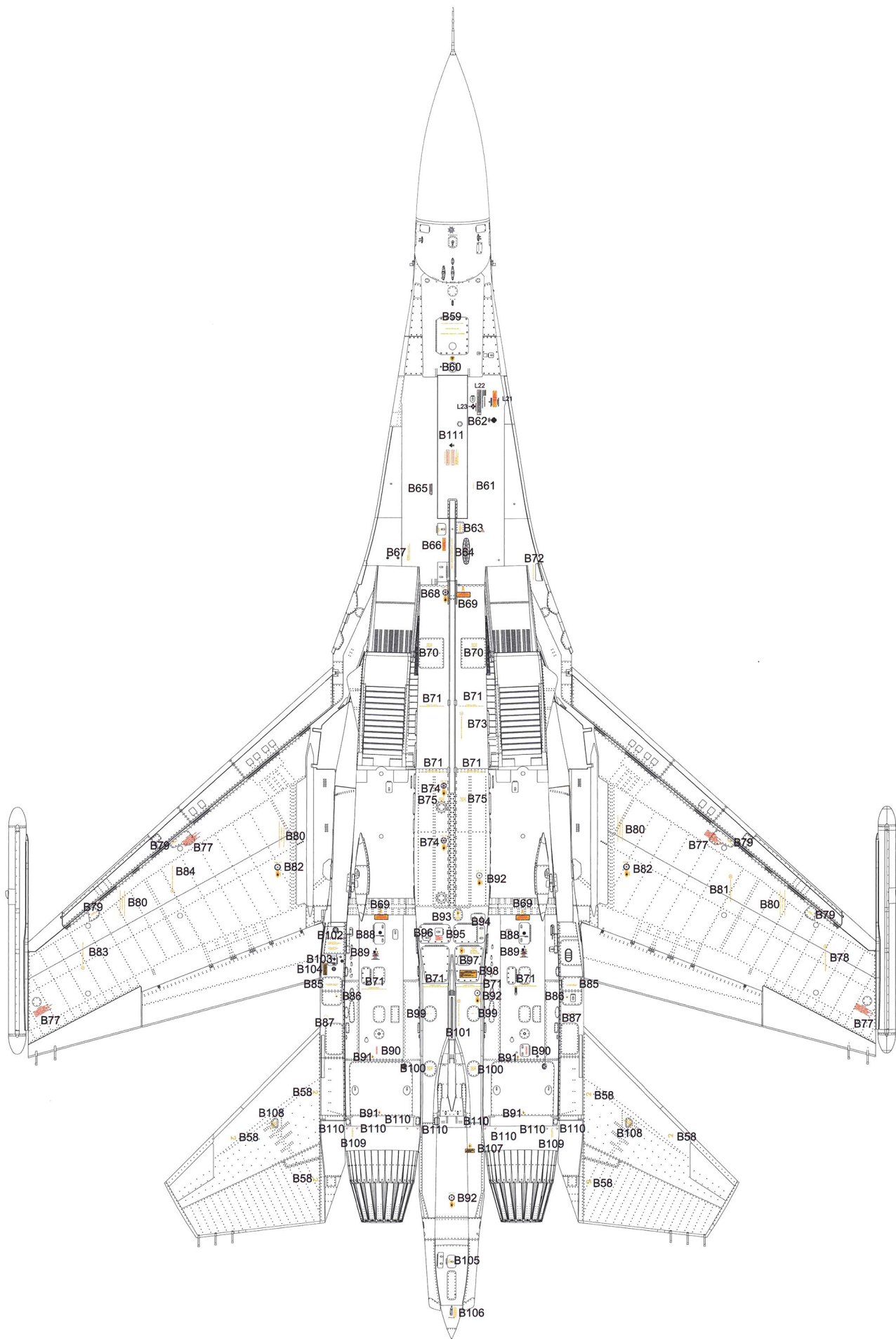

A 苏-27P “红色01” 俄罗斯海军波罗的海舰队第689独立近卫红旗歼击团2003年5月 俄罗斯加里宁格勒契卡洛夫斯克海军基地

Su-27P “Red 01” Russian Navy Baltic Fleet 689th Independent Red Banner GvIAP Kaliningrad Chkalovsk naval air base, Russia, May 2003

生产序列号：36911027920

1989年5月30日出厂

1989年10月7日隶属苏联红海军波罗的海舰队第689独立近卫红旗歼击团，编号为“红色01”

1990年起涂上“苏联近卫军”徽章

1997年4月涂上“鲨鱼嘴”

2003年5月底涂上“眼镜蛇眼”、“鲨鱼嘴”重涂为“眼镜蛇嘴”且右侧垂直尾翼涂上“眼镜蛇”标志

2003年9月3日 抵达第275飞机修理厂

2006年1月31日-2007年12月3日 翻新

2014年秋季起处于停飞状态

2016年7月-8月共青城加加林飞机制造厂（KnAAZ）团队修复该机并延长寿命

2016年11月回到第689团并获得新战术编号“红色99”号

RF-33734

2018年12月1日飞往第275飞机修理厂翻新

2020年2月12日完成翻新并返回基地

2020年秋命名为“叶卡捷琳娜堡号”并使用至今

Serial number: 36911027920

30th May 1989 rollout

7th Oct 1989 numbered as "Red 01" arrived at the regiment Soviet Red Navy Navy Baltic Fleet 689th Independent Red Banner GvIAP

1990 weard the "Guard of the USSR" badge,

Apr 1997 a shark's mouth was painted

End of May 2003 the cobra's eyes were painted, and the "shark mouth" was transformed to the "cobra mouth" and a "cobra" badge was painted on the right vertical fin

3rd Sep 2003 arrived 275th Aviation Repair Plant(ARZ)

31st Jan- 3rd Dec 2007 repaired

From the beginning of autumn 2014 stored

Jul-Aug 2016 repaired and restored by KnAAZ team, aircraft frame life extended

Nov 2016 back to 689th GvIAP and received a tactical number

"Red 99" RF-33734

1st Dec 2018 flew to 275th ARZ;

12th Feb 2020 after the completion of the repair, returned to base

Fall 2020 named as "Yekaterinburg" and still in use now

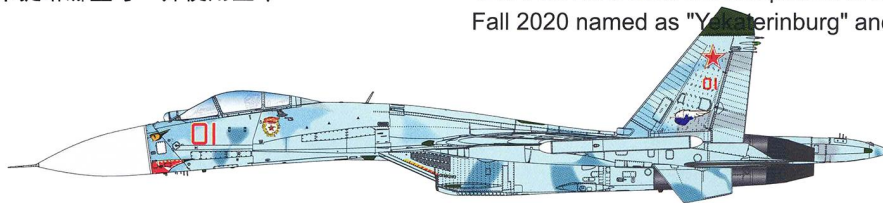

B 苏-27 “红色05” 俄罗斯空军第4军第3近卫歼击团 2006年4月俄罗斯克拉斯诺达尔边疆区克雷姆斯克
Su-27 “Red 05” Russian Airforce 4th Air Army 3rd GvIAP Krymsk, Krasnodar Krai, Russia, April 2006

生产序列号：36911014514

1986年5月8日出厂

1991年4月12日隶属苏联空军第216歼击团，编号为“蓝色19”号

1998年3月8日隶属俄罗斯空军第404歼击团

2001年10月4日隶属第60歼击团

2002年2月15日返回阿穆尔河畔共青城加加林飞机制造厂大修，并重新编号“红色05”号

2005年12月16日隶属第22歼击团

2006年4月21日隶属第3歼击团并编号RF-95617

2013年6月退役

2015年1月报废

Serial number: 36911014514

8th May 1986 rollout

12th April 1991 numbered as "Blue 19" assigned to 216th IAP

8th March 1998 assigned to 404th IAP

4th October 2001 assigned to 60th IAP

15th February 2002 back to KnAAPO, re-numbered as "Red 05"

16th December 2005 assigned to 22nd IAP

21st April 2006 assigned to 3rd IAP number added as of RF-95617

June 2013 written off

January 2015 disposed

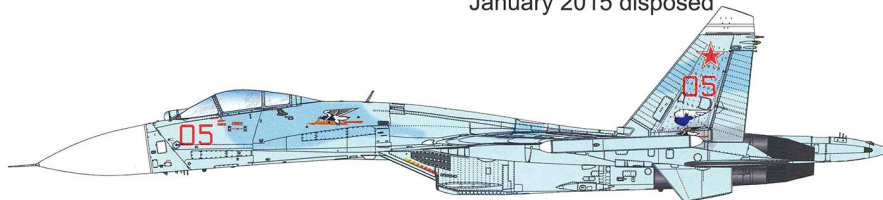

C 苏-27S “红色04” 苏联空军第37军第239师第159近卫红旗歼击团 1991年波兰什切青旧城基地
Su-27S “Red 04” Soviet VVS 37th Air Army, 239th IAD, 159th Red Banner GvIAP Stargard Poland, 1991

生产序列号：36911022001

1987年9月30日出厂获得战术编号“红色14”并隶属于苏联空军第37军第239师第159红旗近卫歼击团

1989年重新编号为“红色04”

2012年3月获得新编号RF-90697并使用至今

Serial number: 36911022001

30th Sep 1987 Roll out and assigned as "Red 14" to Soviet VVS

37th Air Army, 239th IAD, 159th Red Banner GvIAP

1989 received new tactical number "Red 04"

March 2012 received RF-90697 and still in use now

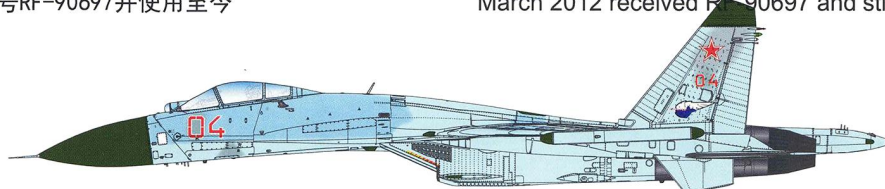

D 苏-27P “蓝色56” 乌克兰空军第831战术航空旅 2004年乌克兰波尔塔瓦州米尔哥罗德基地
Su-27P “Blue 56” Ukrainian Air Force 831st Tactical Aviation Brigade Mirgorod airbase, Poltava Oblast, Ukraine, 2004

生产序列号: 36911031310

1990年4月24日出厂, 隶属苏联空军第100歼击团, 战术编号76

1990年5月首飞

1992年3月17日起隶属乌克兰空军第831战术航空旅, 战术编号56

1997年10月暂时转至第62战术航空旅, 战术编号10

2000年转回第831战术航空旅, 战术编号56

2015年起翻新升级

2017年8月8日翻新升级完成, 服役至今

Serial number: 36911031310

24th Apr 1990 rollout, belonged to 100th KIAP numbered 79

May 1990 first flight

17th Mar 1992 belonged to Ukrainian Air Force 831st Tactical Aviation Brigade, numbered 56

Oct 1997 temporarily transferred to 62th Tactical Aviation Brigade, numbered 10

2000 returned to 831st Tactical Aviation Brigade, numbered 56

2015 after 6-7 years of inactivity, made a flight to ZARZ

8th Aug 2017 repairs completed and in service till now

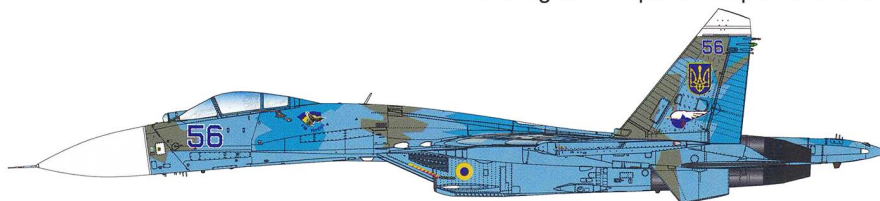

E 苏-27SK “蓝色05” 中国人民解放军空军空三师九团 1992年6月安徽芜湖 中国首批引进苏-27中的第一架单座

Su-27SK “Blue 05” 9th Regiment 3rd Divison PLAAF Wuhu, Anhui Province, China, June 1992
The very first single seater airframe of first batch Su-27 imported to China

首批12架Su-27分别为:

Su-27UBK “01” 13041 生产序列号A1039202

Su-27UBK “02” 13042 生产序列号A1039204

Su-27UBK “03” 13043 生产序列号A1039206

Su-27UBK “04” 13044 生产序列号A1039208

Su-27SK “05” 13045 生产序列号36911038406

Su-27SK “06” 13046 生产序列号36911038407

Su-27SK “07” 13047 生产序列号36911038508

Su-27SK “08” 13048 生产序列号36911038509

Su-27SK “09” 13049 生产序列号36911038710

Su-27SK “10” 13140 生产序列号36911038711

Su-27SK “11” 13141 生产序列号36911038812

Su-27SK “12” 13142 生产序列号36911038813

The first batch of 12 imported Su-27s are:

Su-27UBK “01” 13041 Serial number: A1039202

Su-27UBK “02” 13042 Serial number: A1039204

Su-27UBK “03” 13043 Serial number: A1039206

Su-27UBK “04” 13044 Serial number: A1039208

Su-27SK “05” 13045 Serial number: 36911038406

Su-27SK “06” 13046 Serial number: 36911038407

Su-27SK “07” 13047 Serial number: 36911038508

Su-27SK “08” 13048 Serial number: 36911038509

Su-27SK “09” 13049 Serial number: 36911038710

Su-27SK “10” 13140 Serial number: 36911038711

Su-27SK “11” 13141 Serial number: 36911038812

Su-27SK “12” 13142 Serial number: 36911038813

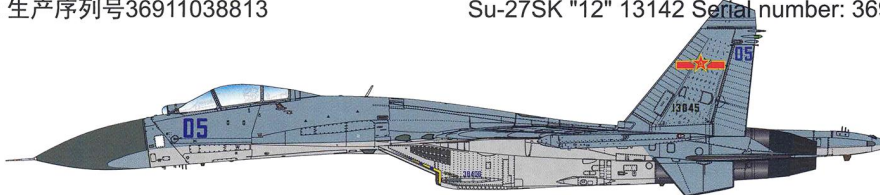

F 苏-27SK “蓝色39” 中国人民解放军空军空二师六团 1996年4月广东遂溪 中国引进的第二批苏-27
Su-27SK “Blue 39” 6th Regiment 2nd Divison PLAAF Suixi, Guangdong Province, China April 1996
One of the second batch Su-27 imported to China

第二批8架Su-27分别为:

Su-27SK “33” 16333 生产序列号36911039306

Su-27SK “34” 16334 生产序列号36911039307

Su-27SK “35” 16335 生产序列号36911039308

Su-27SK “36” 16336 生产序列号36911039409

Su-27SK “37” 16337 生产序列号36911039510

Su-27SK “38” 16338 生产序列号36911039511

Su-27SK “39” 16339 生产序列号36911039512

Su-27SK “40” 16430 生产序列号36911039513

The second batch of 8 imported Su-27s are:

Su-27SK “33” 16333 Serial number:36911039306

Su-27SK “34” 16334 Serial number:36911039307

Su-27SK “35” 16335 Serial number:36911039308

Su-27SK “36” 16336 Serial number:36911039409

Su-27SK “37” 16337 Serial number:36911039510

Su-27SK “38” 16338 Serial number:36911039511

Su-27SK “39” 16339 Serial number:36911039512

Su-27SK “40” 16430 Serial number:36911039513

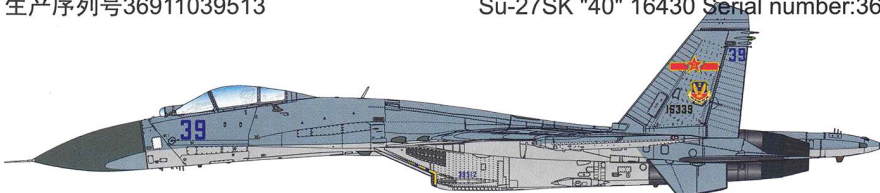



A 本涂装指示按照1/48比例尺寸缩小47%，请放大1.9倍至1/48比例尺寸。
This marking chart has been reduced by 47% from 1/48 scale. Please enlarge by 190% to 1/48 scale size.

- A: 40% C323 + 60% C1
- B: 60% C73 + 40% C1
- C: C323
- D: 50% C72 + 50% C1

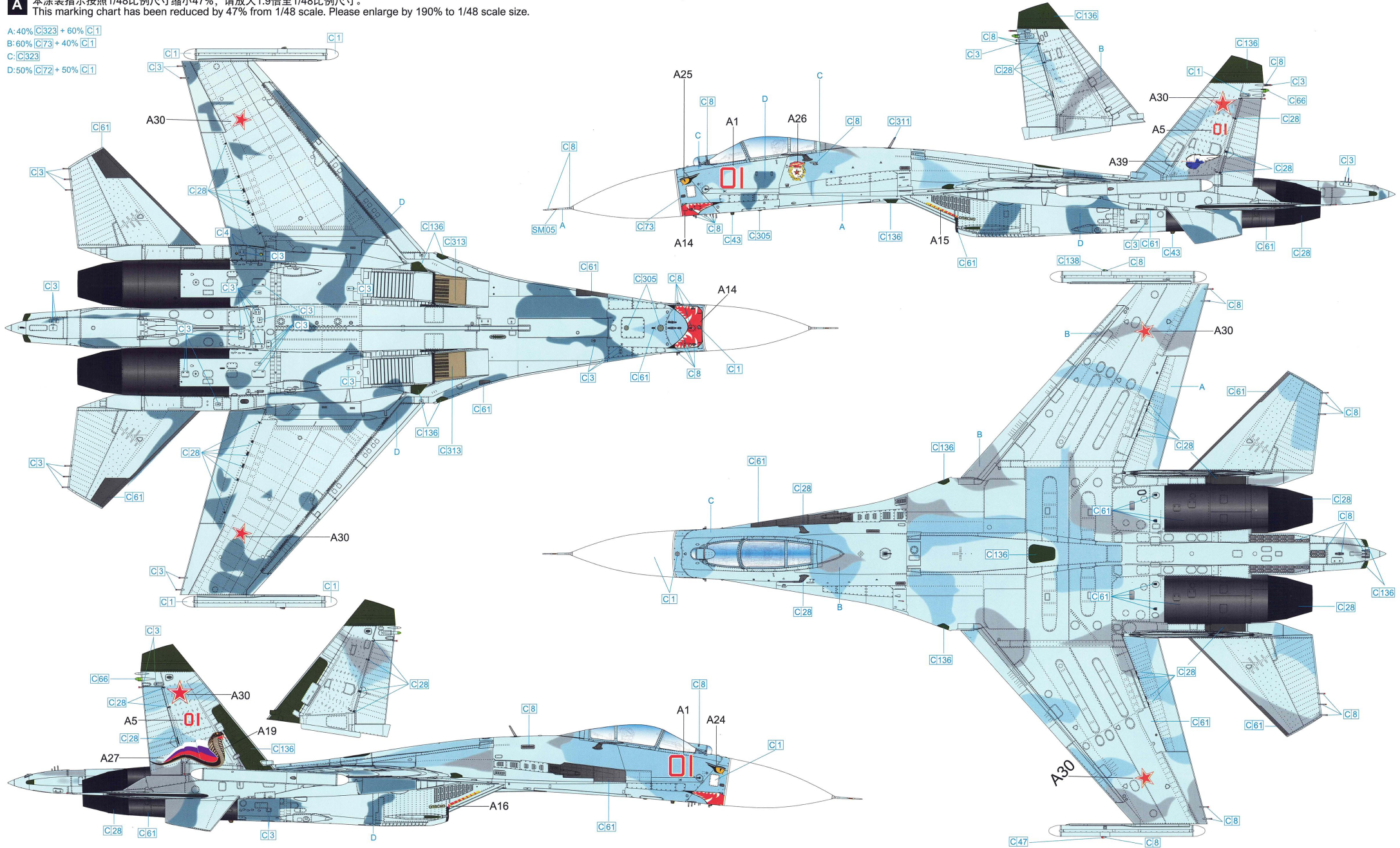



B



Please Refer To Scheme "Red 01" For Colors On Common Details
通用细节颜色涂号请参考“红色01”号涂装

- A: 40% C323 + 60% C1
- B: 60% C73 + 40% C1
- C: C323

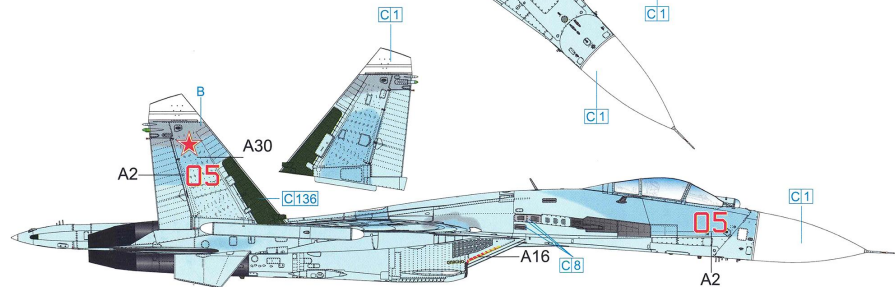
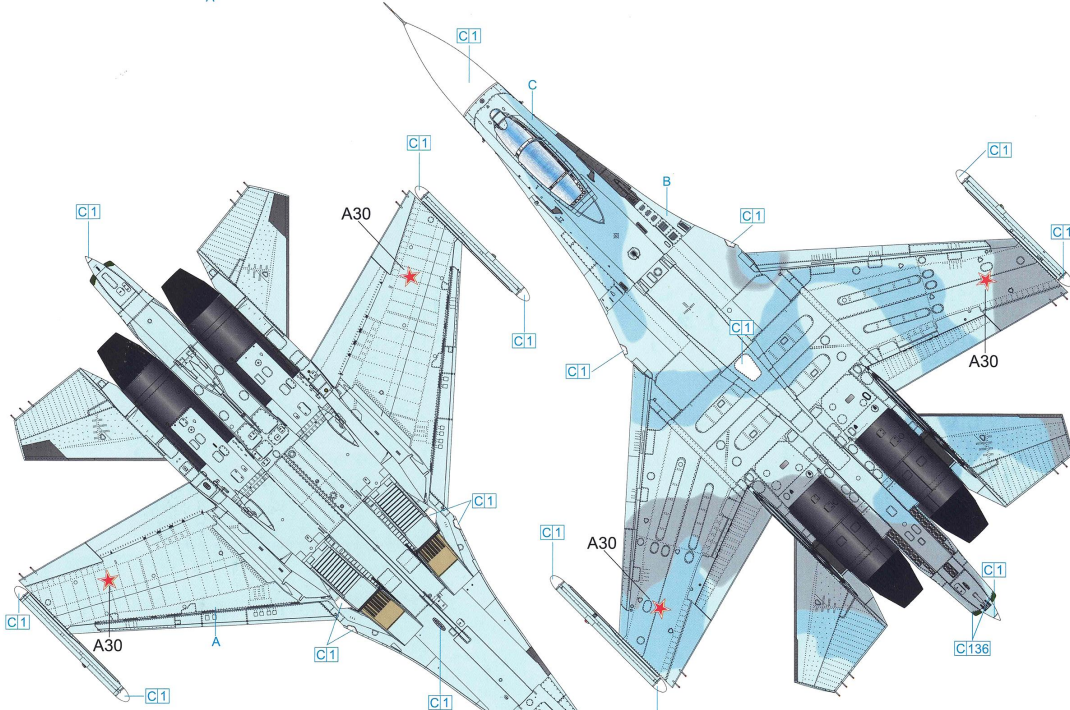
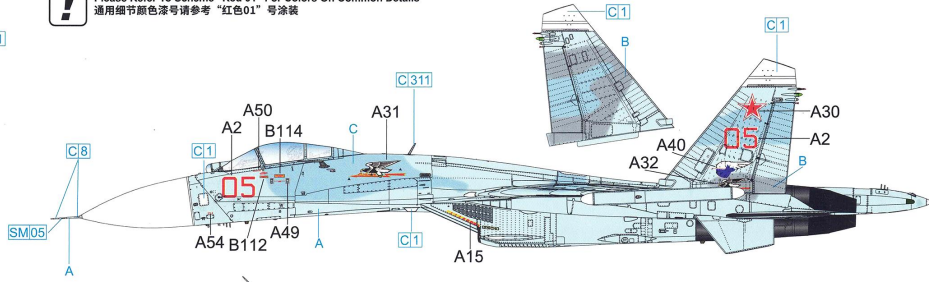

C



Please Refer To Scheme "Red 01" For Colors On Common Details
通用细节颜色涂号请参考“红色01”号涂装

- A: 40% C323 + 60% C1
- B: 60% C73 + 40% C1
- C: C323
- D: 50% C323 + 50% C74

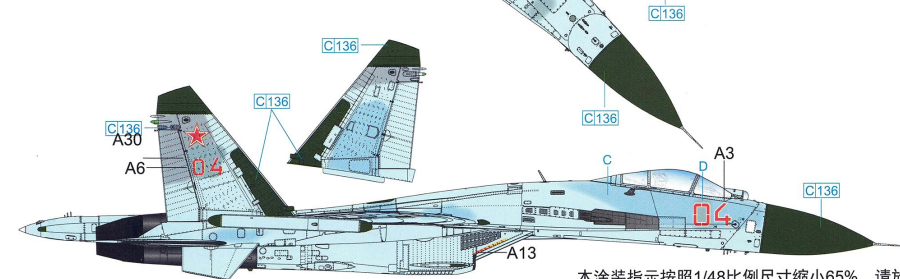
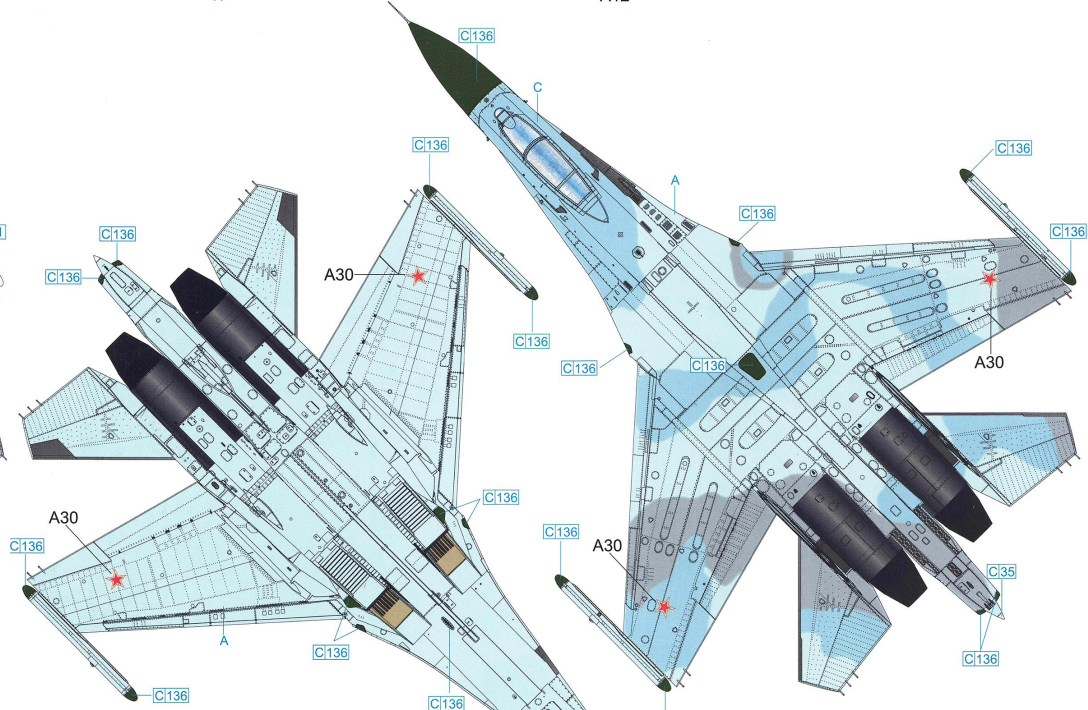
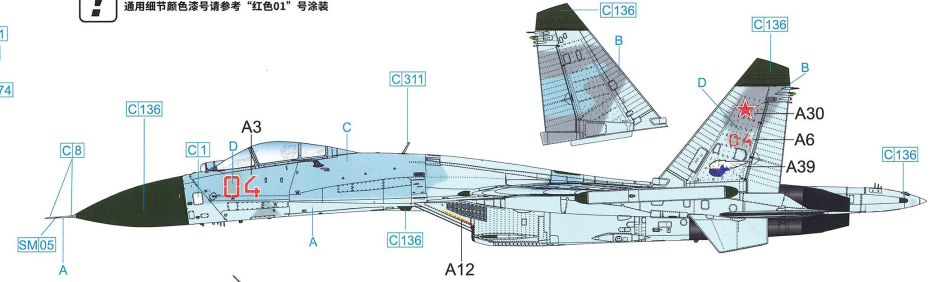

本涂装指示按照1/48比例尺寸缩小65%，请放大2.85倍至1/48比例尺寸
This marking chart has been reduced by 65% from 1/48 scale. Please enlarge by 285% to 1/48 scale size.



D

! Please Refer To Scheme "Red 01" For Colors On Common Details
 通用细节颜色请参考“红色01”号涂装

- A: 30% C34 + 70% C1
- B: C31
- C: C34

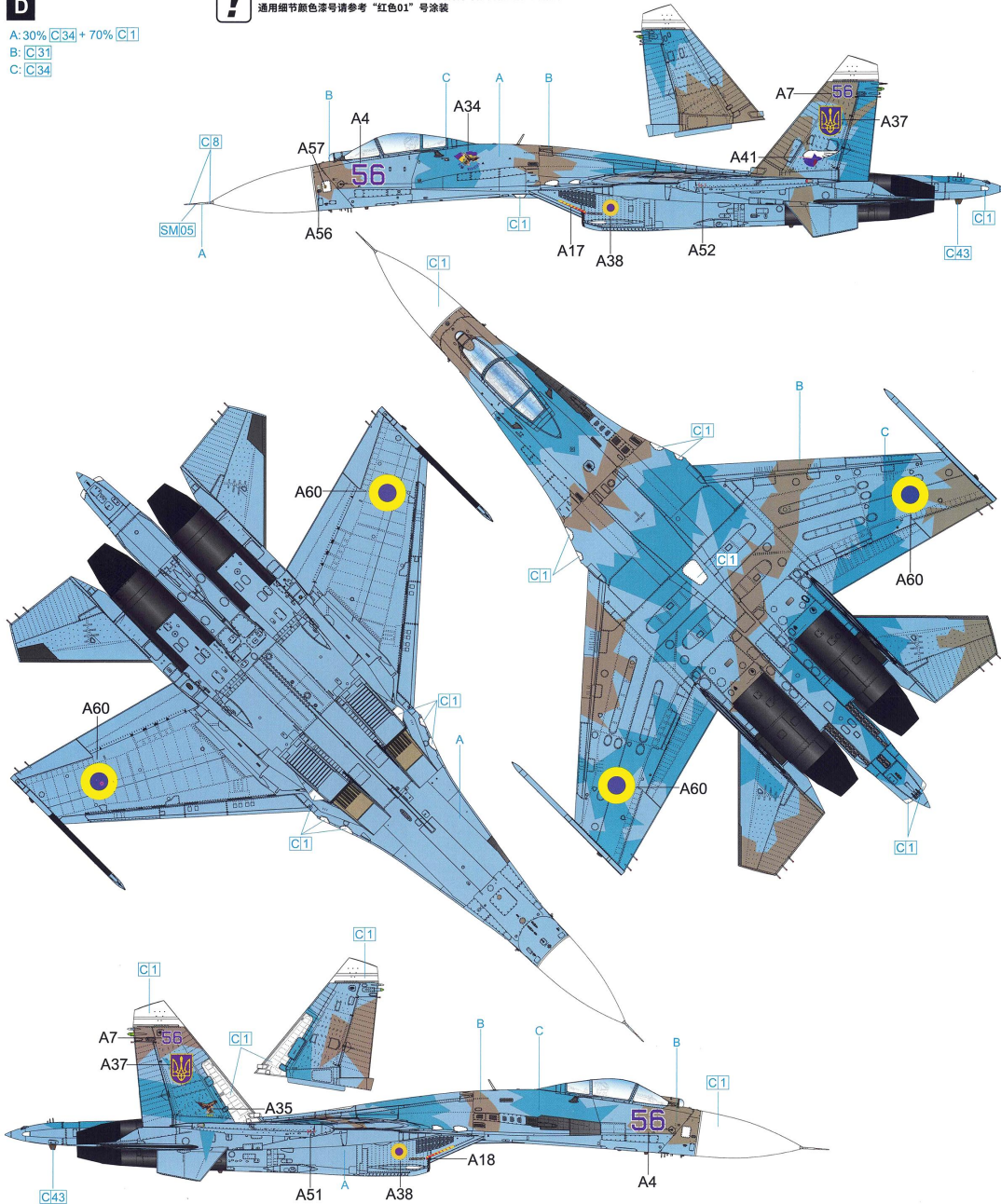

E

! Please Refer To Scheme "Red 01" For Colors On Common Details
 通用细节颜色请参考“红色01”号涂装

- A: 70% C338 + 60% C305
- B: 20% C338 + 80% C305



本涂装指示按照1/48比例尺寸缩小65%，请放大2.85倍至1/48比例尺寸
 This marking chart has been reduced by 65% from 1/48 scale. Please enlarge by 285% to 1/48 scale size.



F Please Refer To Scheme "Red 01" For Colors On Common Details
通用细节颜色编号请参考 "红色01" 号涂装

A: 70% C311 + 60% C305
B: 20% C311 + 80% C305

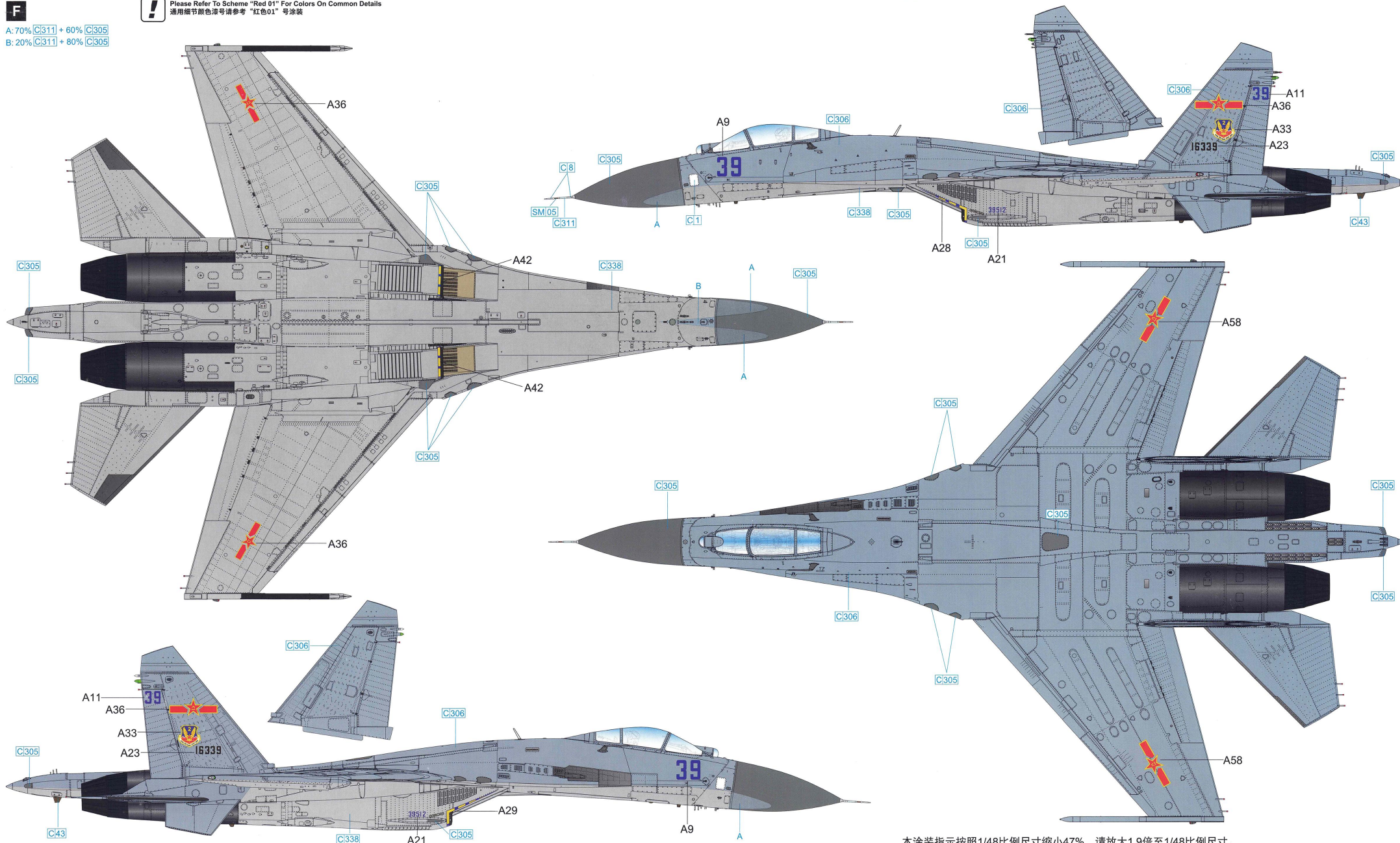

本涂装指示按照1/48比例尺寸缩小47%，请放大1.9倍至1/48比例尺寸。
This marking chart has been reduced by 47% from 1/48 scale. Please enlarge by 190% to 1/48 scale size.