

A

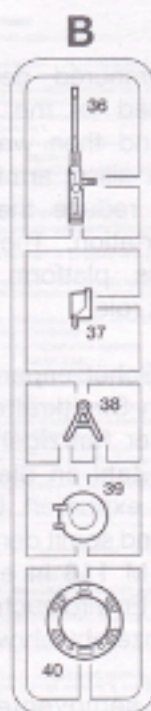

B

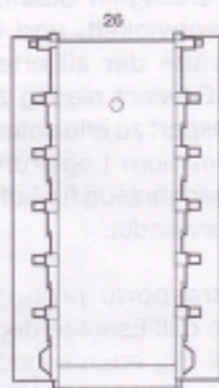

X

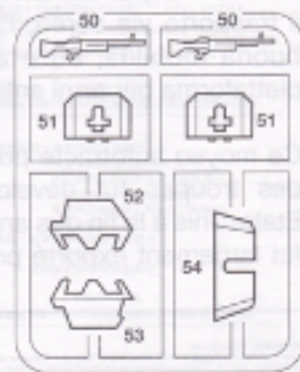

D

Legende colori: I numeri si riferiscono all'assemblaggio colori (ITALI MODELMASTER)
 Painting instruction: The indicated colour numbers refer to the ITALI MODELMASTER
 Bemalungsanweisung: Die angegebenen Farbzahlen beziehen sich auf die ITALI MODELMASTER
 Mode d'utilisation de la peinture: Les références indiquées concernent les peintures ITALI MODELMASTER

A

FLAT BLACK

F.S. 37038

MODEL MASTER - 1749

MODEL MASTER ACRYL - 4768

B

GUN METAL

MODEL MASTER (METALLIC) - 1405

MODEL MASTER ACRYL - 4681

C

OLIVE DRAB (FLAT)

F.S. 37057

MODEL MASTER - 1711

MODEL MASTER ACRYL - 4728

D

INSIGNA WHITE (GLOSS)

F.S. 17875

MODEL MASTER - 1745

MODEL MASTER ACRYL - 4696

1

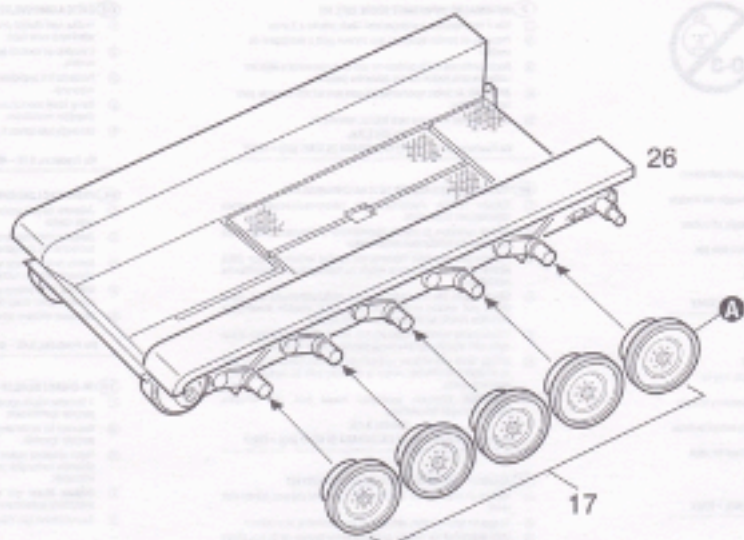

2

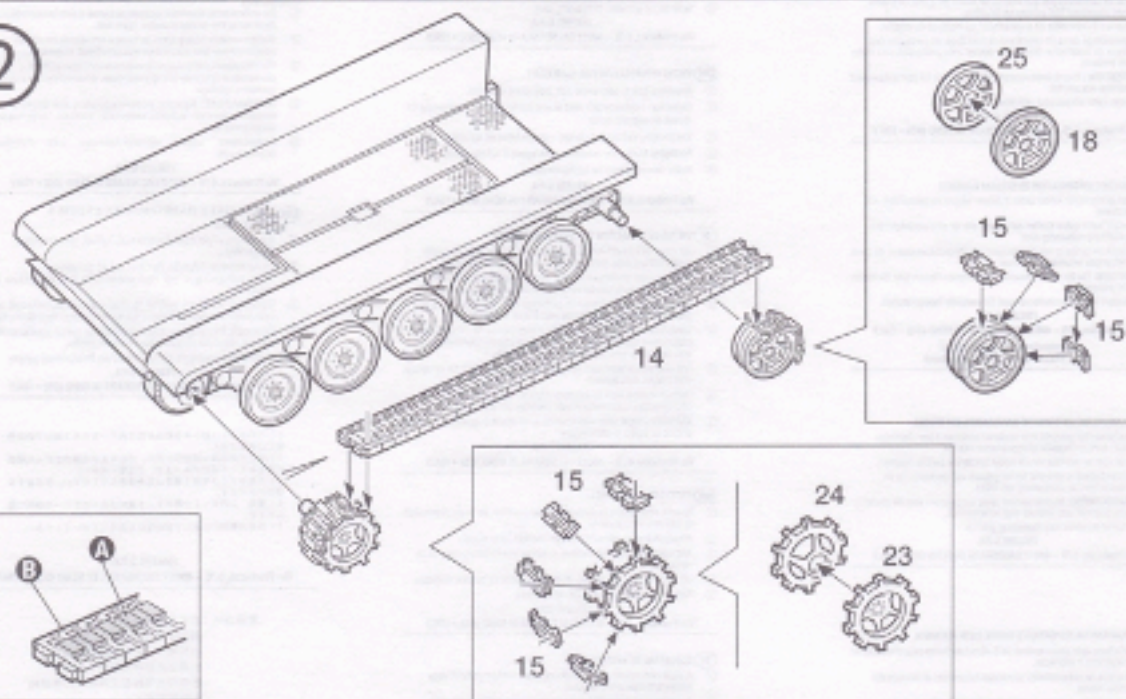

3

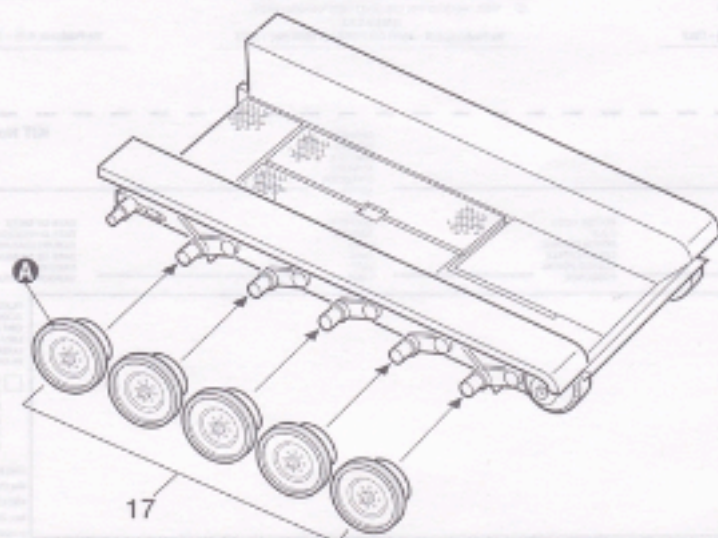

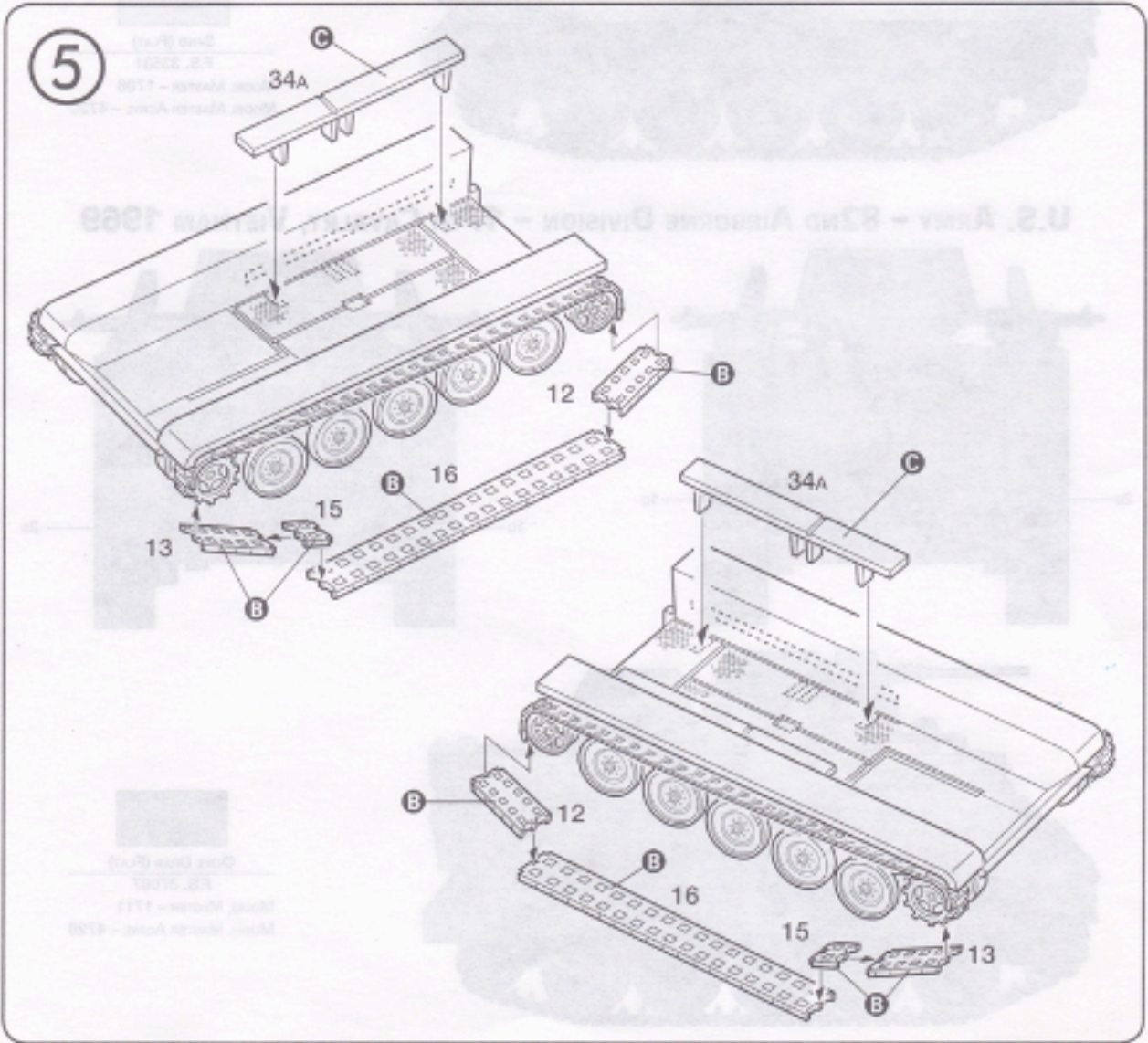
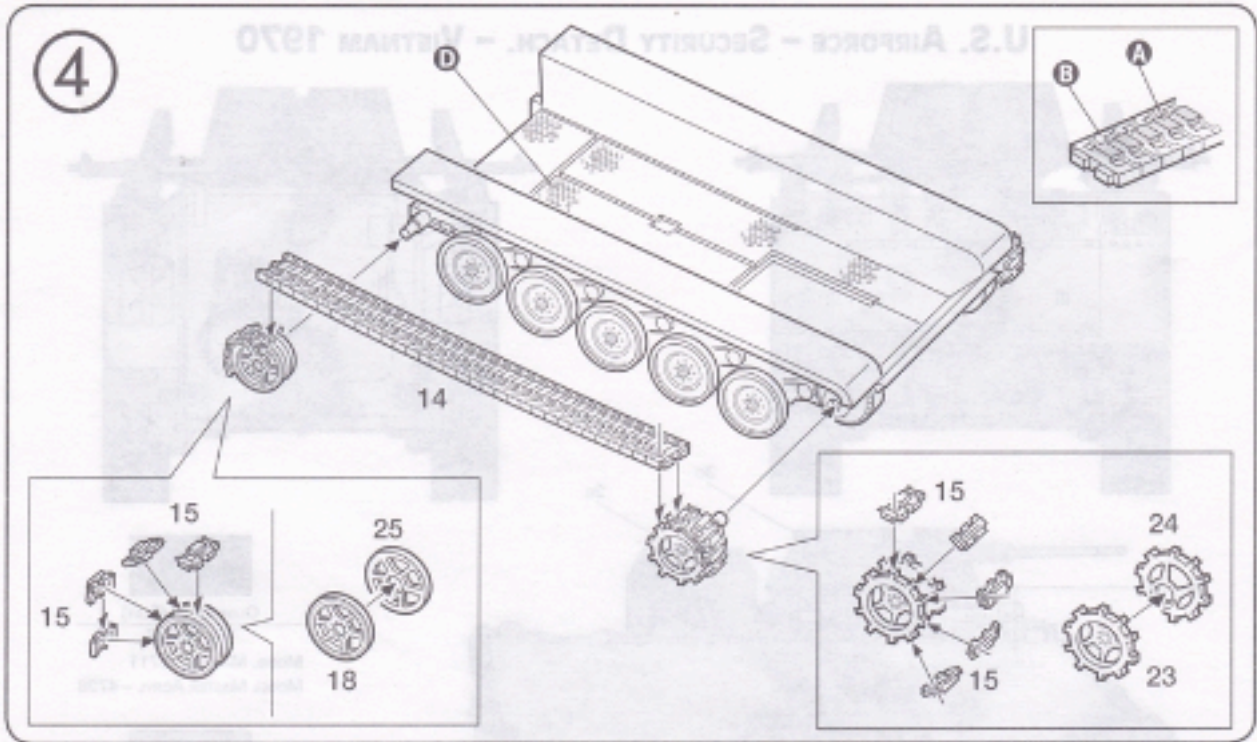

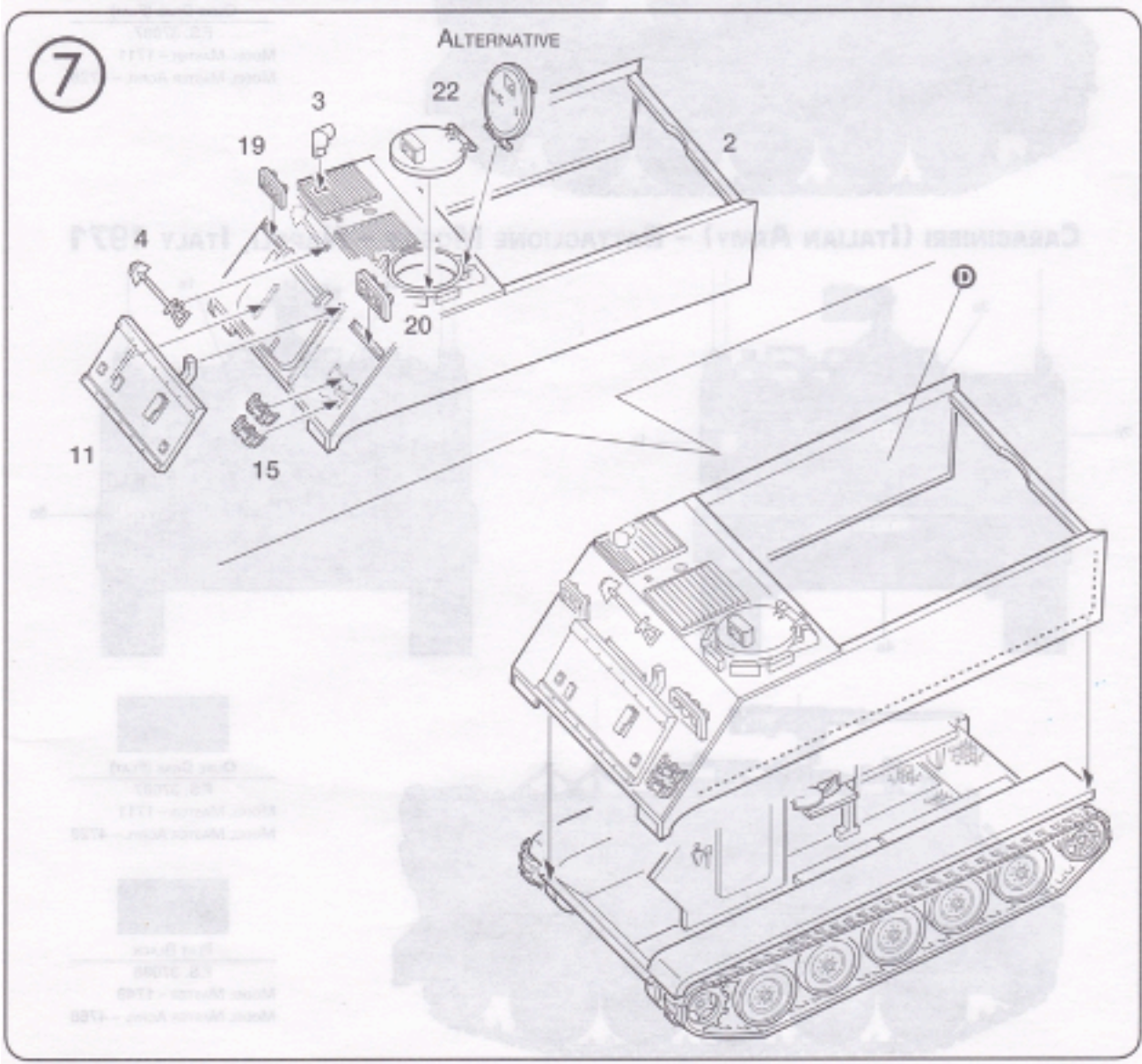
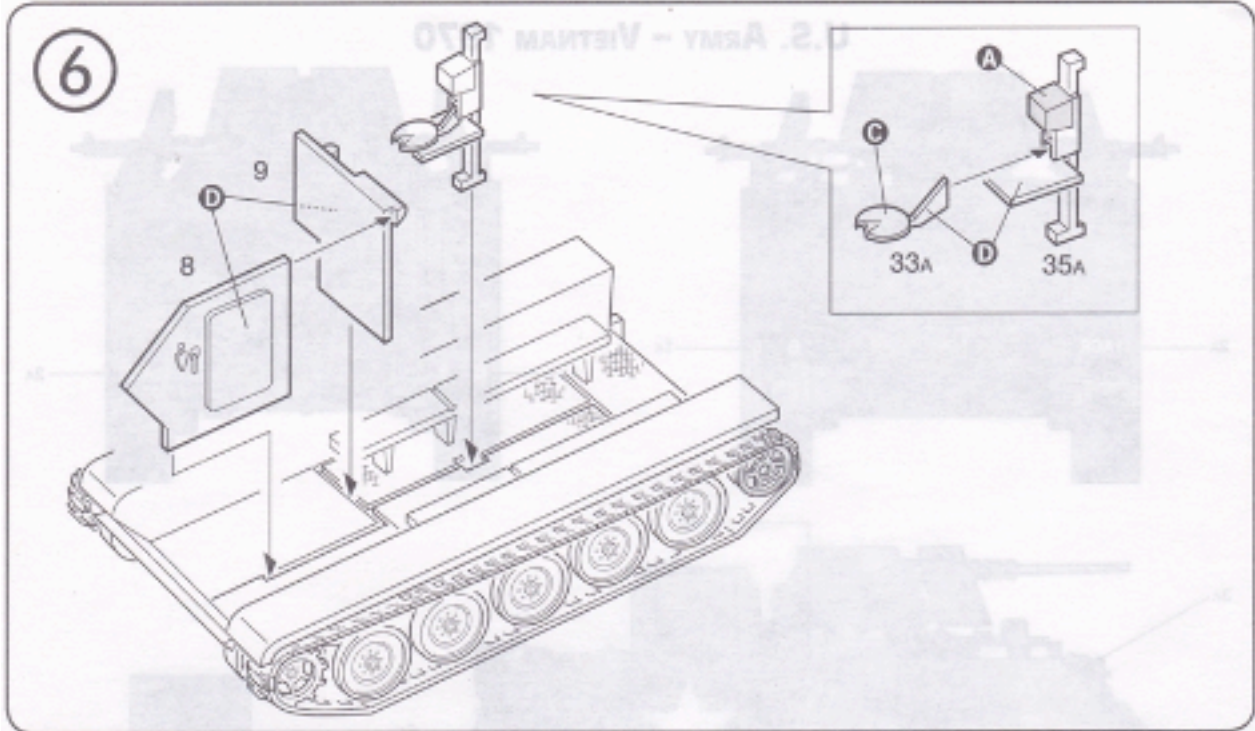

10 VERSIONS A - C - D

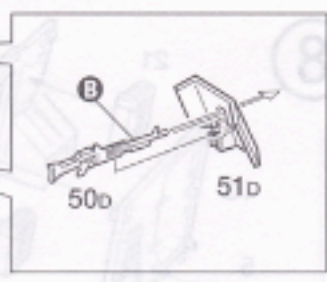
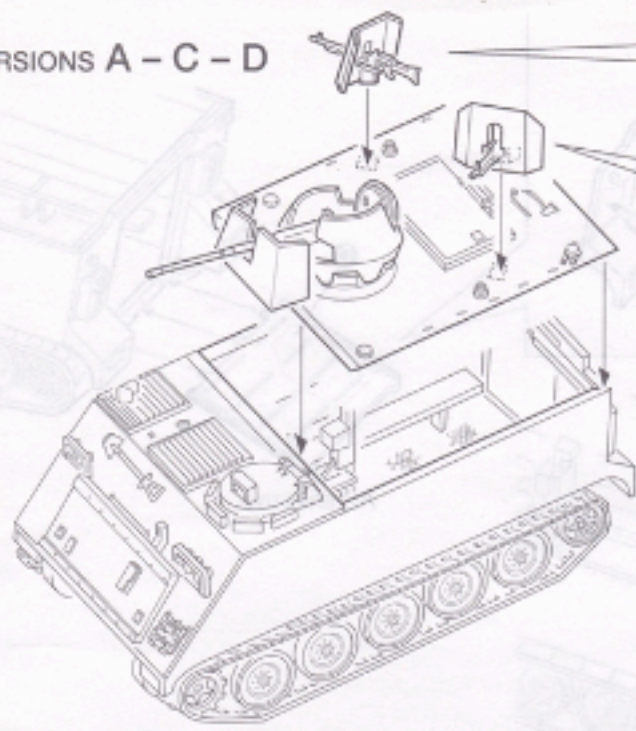

10 ONLY VERSION B

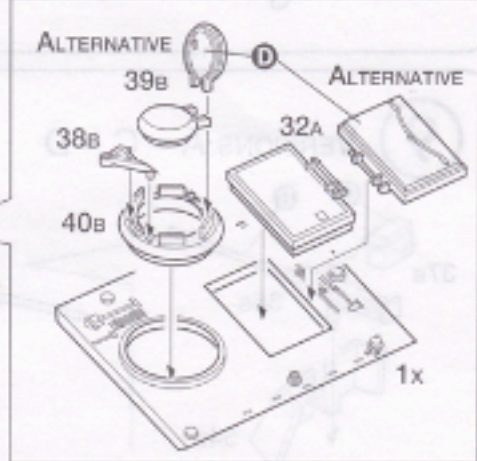
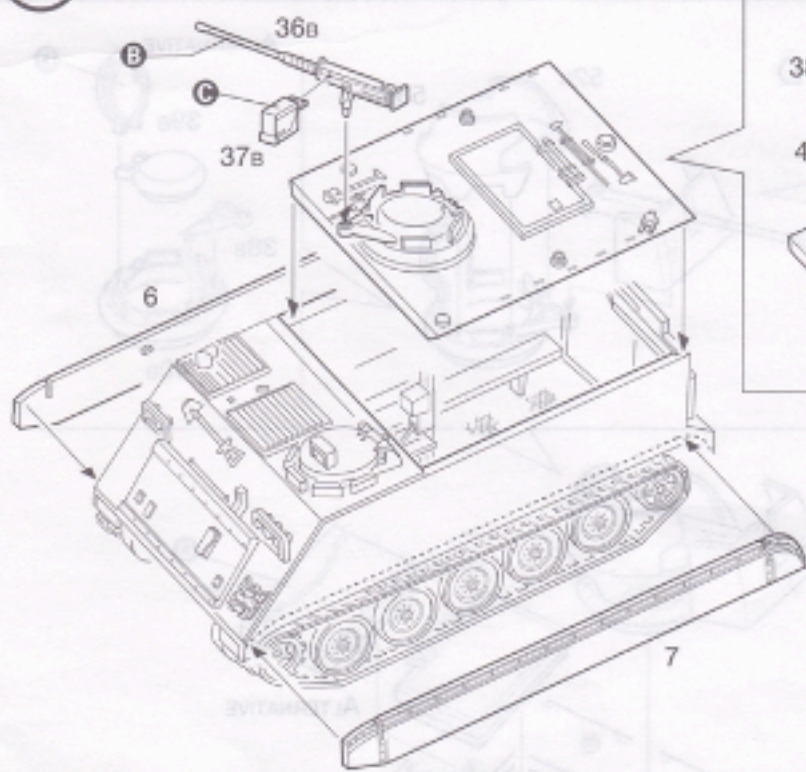

istruzioni per l'applicazione delle decalcomanie. Rimuovere le decalcomanie necessarie dal foglio, immergerle in un contenitore l'acqua pulita per circa 1/2 minuto, metterle in posizione sul rotolo e fare scivolare dalla carta per una migliore adesione. Premere con una pezzola pulita.

Instructions for applying the decals: Cut the required decals out of the sheet and then into a glass of clean water for about 1/2 minute, position the decals on the kit, letting them slide from the paper. For a better adhesion, press them by means of a clean rag.

Instruktion av decalerna: Klipp ut den decal som ska användas och lägg den i ett glas vatten under en 1/2-minut. Sätt decalerna på rullen på en sådant sätt att de ska glida från pappret. För att få en bättre adhesion, tryck till med en ren duk.



Anweisungen für Abziehbilder-Anbringung: Die benötigten Abziehbilder vom Blatt abschneiden, in ein Glas reines Wasser für etwa 1/2 Minute einweichen, auf das Modell legen und dann vom Papierbogen abgleiten. Um eine bessere Haftung zu erzielen, die Abziehbilder mit einem reinen Tuch andrücken.

Instruction pour l'application des décalcomanies: Couper les décalcomanies nécessaires et les plonger environ 1/2 minute dans un peu d'eau propre. Les placer sur le modèle en les faisant glisser de leur feuille et presser avec un morceau de chiffon pour obtenir une bonne adhérence.

Instrukcijas: Pirms aplīmēšanu ar decalēm: noņemiet nepieciešamās aplīmēšanas daļiņas no lapa, iemērciet tās tīrā ūdenī apmēram 1/2 minūti, uzklājiet uz modeļa, ļaujot tām slidēt no papīra. Lai nodrošinātu labāku adhēziju, piespiediet tās ar tīru drāni.

Transfer: Rip the required decal out, dip it for ca. 1/2 minute under water, hold it transfer paper and model on which the decal will be pasted, then use a clean dry rag to press it.

INFORMAZIONE: PER INFORMAZIONI SULLE DECALCOMANIE, VISITATE IL SITO WWW.PAPERBROTHER.COM O CONTATTATE IL SERVIZIO CLIENTI AL NUMERO VERDE 800 20 20 20.

Verweise zu weiteren Informationen: Besuchen Sie unsere Website oder kontaktieren Sie unseren Kundendienst unter der kostenlosen Rufnummer 800 20 20 20.

U.S. AIRFORCE - SECURITY DETACH. - VIETNAM 1970

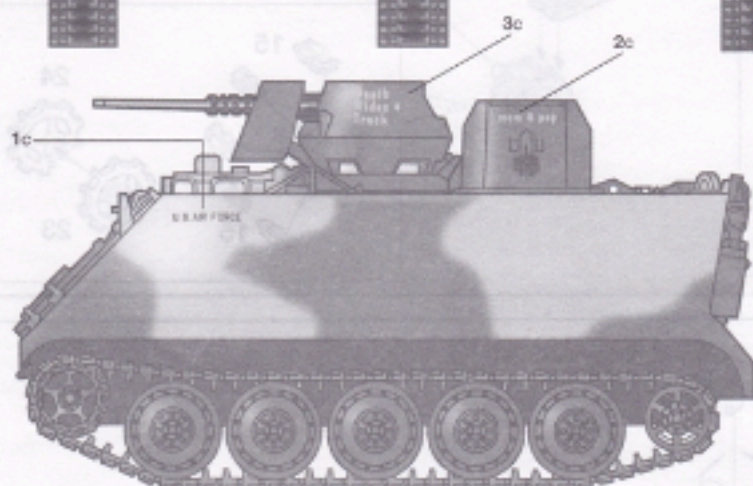
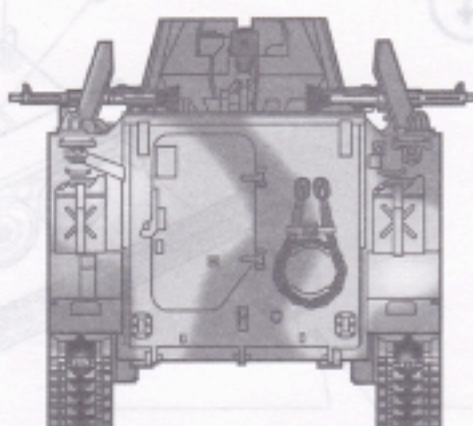
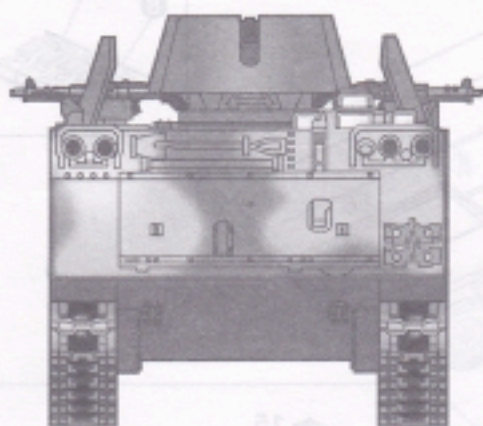

OLIVE DRAB (FLAT)

F.S. 37087

MODEL MASTER - 1711

MODEL MASTER ACRYL - 4728

SAND (FLAT)

F.S. 33531

MODEL MASTER - 1706

MODEL MASTER ACRYL - 4728

U.S. ARMY - 82ND AIRBORNE DIVISION - 17TH CAVALRY, VIETNAM 1969

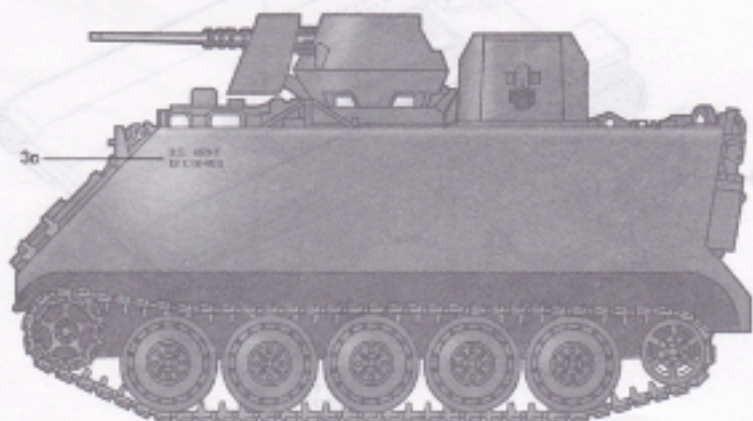
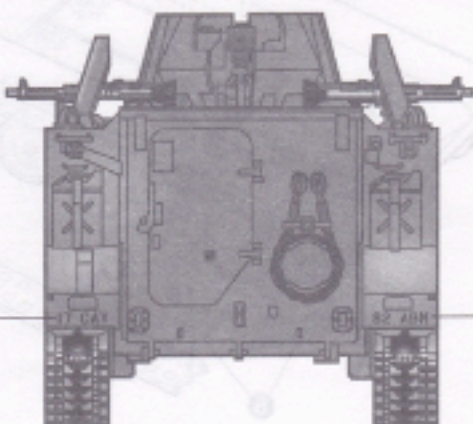
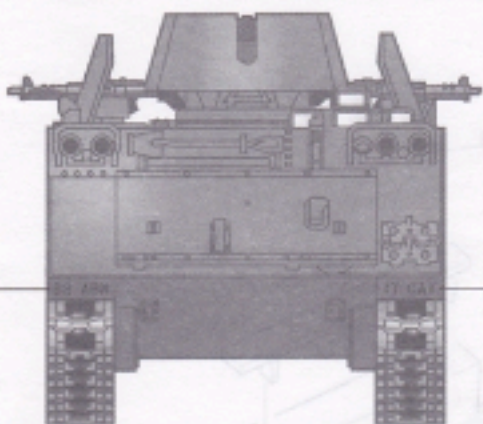

OLIVE DRAB (FLAT)

F.S. 37087

MODEL MASTER - 1711

MODEL MASTER ACRYL - 4728

U.S. ARMY - VIETNAM 1970

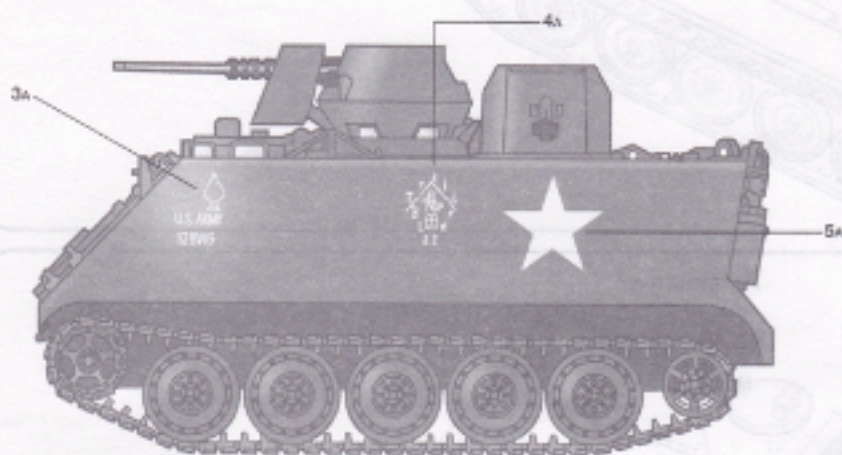
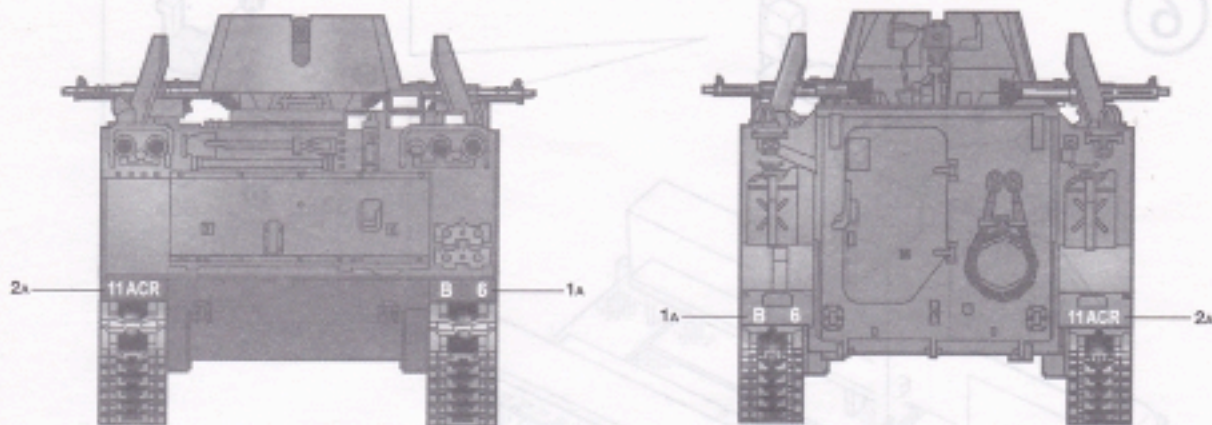

OLIVE DRAB (FLAT)

F.S. 37087

MODEL MASTER - 1711

MODEL MASTER ACRYL - 4728

CARABINIERI (ITALIAN ARMY) - BATTAGLIONE MOBILE - NAPOLI, ITALY 1971

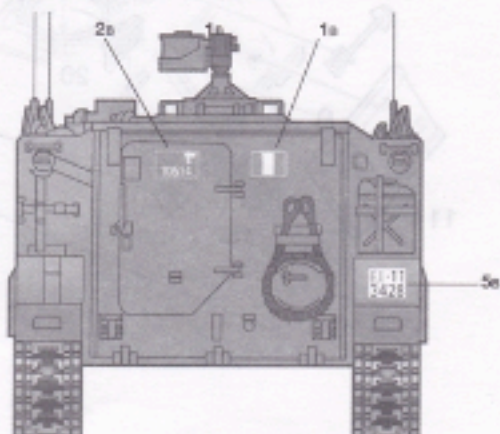
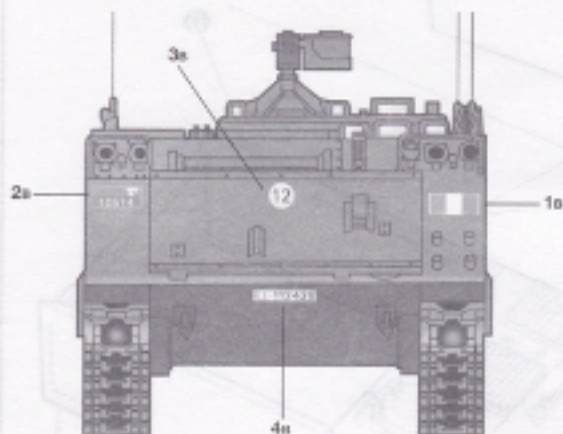

OLIVE DRAB (FLAT)

F.S. 37087

MODEL MASTER - 1711

MODEL MASTER ACRYL - 4728

FLAT BLACK

F.S. 37038

MODEL MASTER - 1749

MODEL MASTER ACRYL - 4788