

PANZER IV F1-F2-G

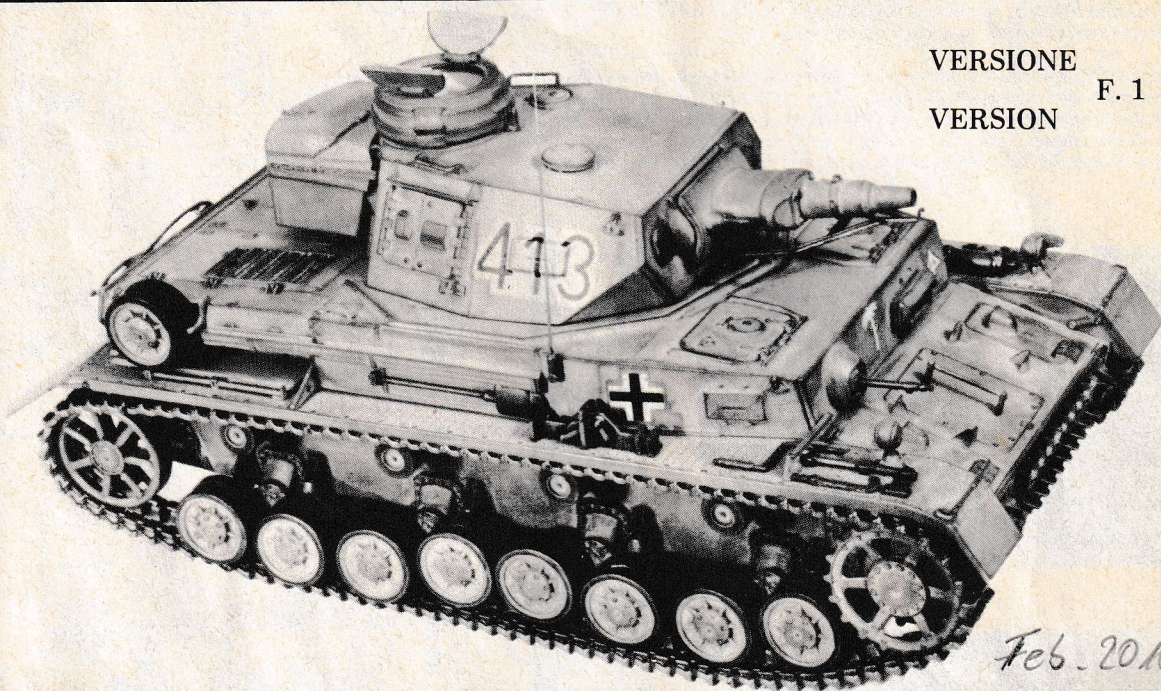

VERSIONE F. 1
VERSION

PANZERKAMPFWAGEN IV AUSFÜHRUNG F1 F2/G

Il Panzerkampfwagen IV è certamente uno dei carri più famosi e più usati tra quelli prodotti dall'industria bellica tedesca. Nonostante ciò nel febbraio del 1943 esso stava per essere radiato dall'esercito per lasciare spazio alla produzione del carro Tigre e solo il risoluto intervento di Guderian ne impedì l'arresto della produzione che avrebbe privato la Wehrmacht di una delle armi più potenti e versatili in uno dei momenti più critici della guerra. Esso nacque nel 1934 dalla necessità di disporre di un carro per appoggiare il tipo standard III. La produzione vera e propria fu iniziata da Krupp nel 1936 e si concluse alla fine della guerra con circa 9.000 unità prodotte, distribuite in 10 differenti versioni, via via migliorate e potenziate; fra esse le A-B-C-D-E-F1 montavano un cannone a canna corta da 75 L 24. La scatola comprende la versione F1 con canna corta e le versioni F2 - G che furono le prime ad installare un pezzo a canna più lunga. La versione F2 fu imposta dalla necessità di far fronte ai nuovi carri e alle armi anticarro sempre più potenti di cui erano dotati gli avversari della Germania. Già dal novembre 1941 si era richiesto per il Panzer IV un'arma a canna lunga ed il pezzo prescelto fu il 75 L 43 che venne installato nei primi mesi del 1942 e che consentiva un tiro più teso e più veloce. Questa versione fu denominata AUSFÜHRUNG F2 ed era riconoscibile per il tipico freno di bocca del cannone a forma globulare. Anche il modello G montava lo stesso pezzo, munito ora di un doppio freno di bocca, ed era in sostanza il risultato di tutte le migliorie introdotte nella serie precedente. Lo scafo del Panzer IV era costituito da piastre saldate ed era diviso in tre compartimenti dei quali; quello anteriore ospitava la guida, quello centrale la camera di combattimento con i serbatoi, del carburante nella parte bassa, quello posteriore il gruppo propulsore che era un MAYBACH HL 120 TRM da 11867 cm³. Su ciascun lato il rotolamento era assicurato da quattro, carrelli di due rulli doppi, gommati nella parte esterna, con sospensioni a balestra, quattro rulli reggi cingolo, ruote motrici anteriori e di tensione posteriore. Inizialmente, durante le operazioni in Cecoslovacchia e la campagna di Polonia, il carro modello IV equipaggiava la quarta compagnia di ogni battaglione corazzato; successivamente esso fece parte della compagnia pesante d'appoggio, alla diretta dipendenza del comando di battaglione. Dall'operazione Barbarossa in avanti, il carro modello III si dimostrò superato ed il modello IV, via via modificato nella protezione e nell'armamento, equipaggiò la maggior parte dei battaglioni corazzati. Questo carro ebbe modo di distinguersi in tutti i teatri di operazione della II Guerra mondiale: dall'Africa, dove fu un terribile avversario per il reparto Inglese, fino alla Russia, dove affrontò i potenti carri ed armi anticarro dell'armata rossa. Negli anni più recenti, il Panzer IV ha dato ancora una volta prova della sua validità combattendo con le insegne siriane nella breve guerra del 1956 contro Israele. **Caratteristiche:** Denominazione - Pz Kpfw Ausf. F1-F2 (Sd Kfz 161) G (Sd Kfz 161/1) - Equipaggio: 5 uomini - Peso in combattimento: F1 22300 Kg F2-G 23600 Kg - Lunghezza max F1 5,93 m F2-G 6,63 m - Larghezza max.: 2,88 m - Altezza max.: 2,68 m - Armamento: F1 7,5 L 24 KwK F2-G 7,5 L 43 (KwK 40) in torre girevole con 80 colpi F1 e 87 colpi F2-G Elevazione: + 20° - 10° 2 MG 7,92 una coassiale e una in casamatta - Velocità max. su strada: F1 42 Km/h F2-G 40 Km/h su terreno vario: F1 20 Km/h F2-G 16 Km/h - Autonomia: 200/130 Km.

PANZERKAMPFWAGEN IV AUSFÜHRUNG F1 F2/G

Of all the tanks produced by the Germans the PzKpfw IV F2 - G is one of the best known and most widely used armoured fighting vehicles. However, in February, 1943 its production was about to be discontinued in order to make room for the Tiger Tank, and only because of the determined intervention of General Guderian was the production continued. Otherwise the Wehrmacht would have been deprived of one of its most powerful and versatile weapons of World War II. It was first produced in 1934 because of the need to have a tank available to support the standard Type III. The actual production was started in 1936 by Krupp, and by the end of the War about 9.000 units had been produced from ten different versions. The vehicle was improved greatly and made more powerful. The earlier types were called A-B-C-D-E-F1, the last mentioned mounted a 75mm gun L24 with a short barrel. The box contains the F1 version with a short barrel and the F2 - G versions, which were the first types that mounted a gun with a longer barrel. The F2 version was produced because of the need to face the more powerful new tanks and the specialised anti-tank weapons with which the enemies of Germany were equipped. After November, 1941 the Panzer IV had a long barrelled weapon and the type chosen was the 75 L 43. This was installed during the first month of 1942 and permitted a lower angle of depression and also more rapid fire. This version was called Ausführung F2 and was recognizable by the typical globe shaped muzzle brake of the gun. The Type G mounted the same gun, now equipped with a double muzzle brake. This tank was, in substance, the result of all the improvements introduced in the preceding types. The hull of the Panzer IV was made of welded plate construction and it was divided into three compartments. In the front was the driver and his controls, in the centre the fighting compartment with the fuel tanks placed on the floor either side, and at the rear the engine was situated. This was a Maybach HL 120 TRM with a capacity of 11.867 litres. The running gear consisted of 4 pairs of double wheels on each side, with solid rubber tyres, each pair with a cantilever type suspension. There were four top rollers to support the track, and driving sprockets were at the front, the rear most wheels being used for track tensioning. At the beginning of World War II during the operations in Czechoslovakia, and Poland, the 4th Company of each Armoured Battalion was equipped with the Panzer IV. Subsequently it became part of the heavy support company which was directly commanded from Battalion H.Q. From the time of the Barbarossa Campaign it was seen that the Panzer III was obsolete and most of the armoured battalions were subsequently equipped with the Model IV which was gradually modified in its armour and fire power. This tank distinguished itself in all the theatres of World War II, from Africa, where it was indeed a terrible enemy for the British, to Russia, where it gallantly faced the more powerful tanks and anti-tank weapons of the Russian Army. Even as recently as 1956 the Panzer IV gave proof of its effectiveness when it was found to be fighting under Syrian Colours during the short war against Israel. **Data:** Name Pz Kpfw Ausf. F1-F2 (Sd Kfz 161) G (Sd Kfz 161/1) - Crew: 5 men - Weight in Action: F1 22.300 kgs F2-G 23.600 kgs - Max. Length: F1 5.93 m F2-G 6.63 m - Max Width: 2.88 m - Max Height: 2.68 m - Armament: F1 7.5 L 24 KwK F2-G 7.5 L 43 (KwK

Prima di iniziare il montaggio studiare attentamente il disegno. Montare i pezzi seguendo l'ordine della numerazione, si consiglia di sottolineare ogni volta il numero del pezzo montato. Le frecce nere indicano i pezzi da incollare, le frecce bianche indicano i pezzi da montare senza colla. Usare solo colla per polistirolo.

Before starting assembly carefully study the exploded drawings. Assemble parts following the number sequence and cross off each part number of the drawing as it is fitted. Black arrows indicate parts to be glued together, white arrows indicate parts to be fitted without gluing. Use only glue suitable for polystyrene.

Avant de commencer l'assemblage étudier attentivement la vue éclatée. Assembler les pièces selon l'ordre prescrit et biffer au fur et à mesure sur la table le numéro de la pièce montée. Les flèches noires indiquent les parties à coller, les flèches blanches les parties à ne pas coller. Employer exclusivement de la colle à polystyrène.

Vor dem Zusammenbau Übersichtszeichnung sorgfältig prüfen. Die Teile sind nach der angegebenen Zahlenfolge zu montieren. Es wird empfohlen die Nummer des montierten Teils jedesmal durchzustreichen. Schwarze Pfeile zeigen Teile die zu kleben sind, weiße Pfeile zeigen Teile die ohne Klebstoff montiert werden. Bitte nur Polystyrol-Klebstoff verwenden.

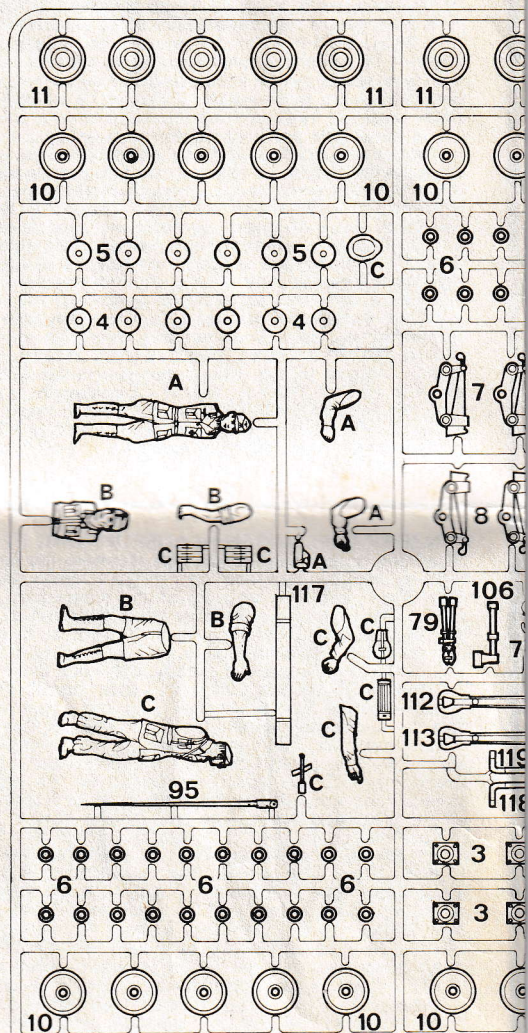
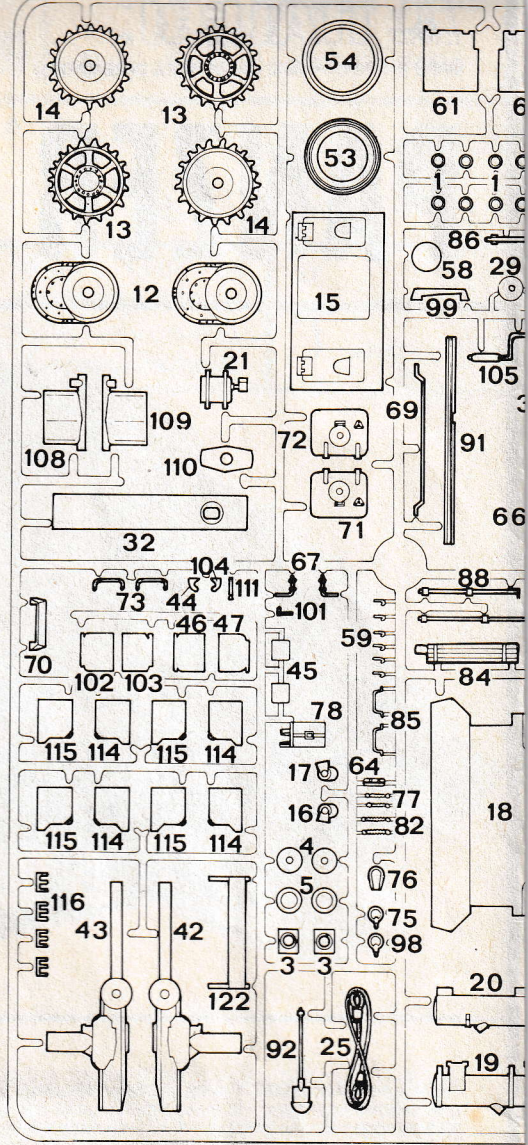
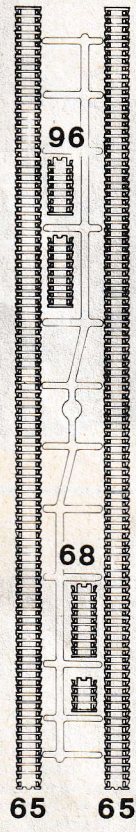
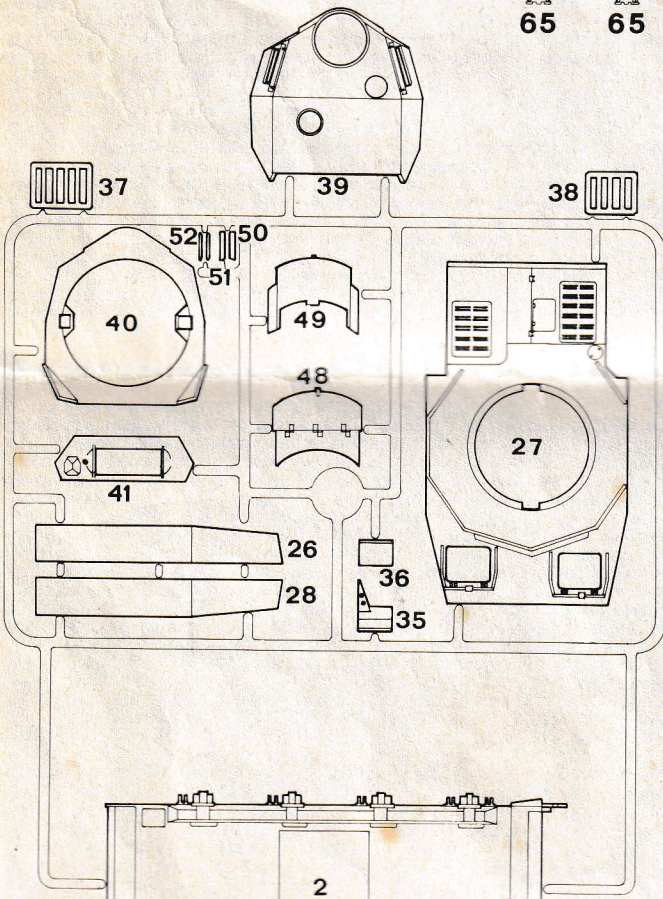
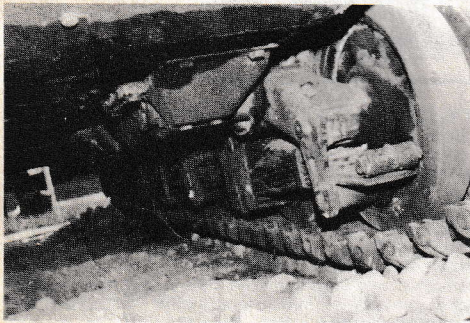
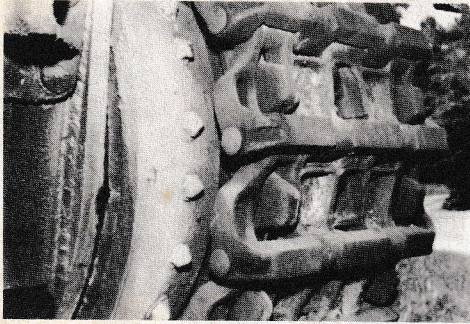

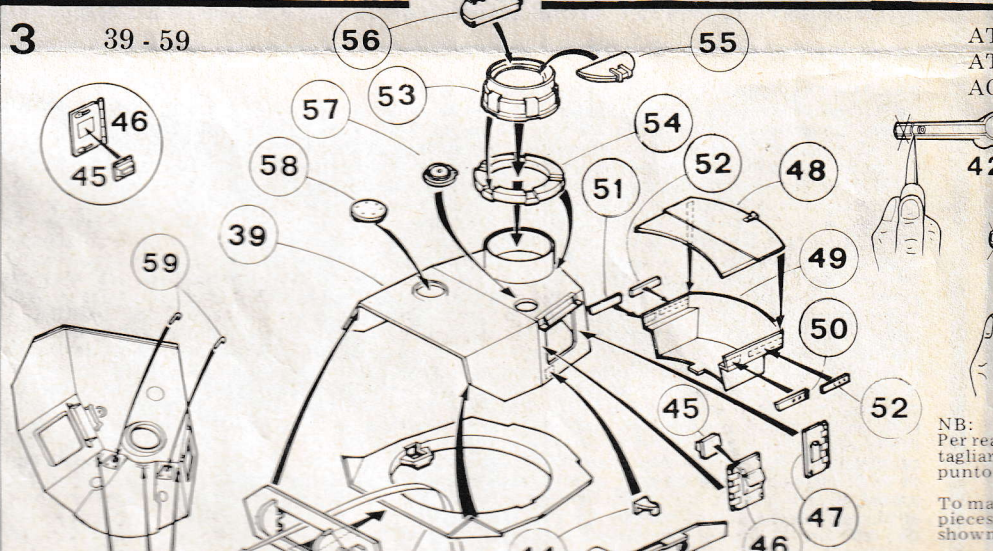
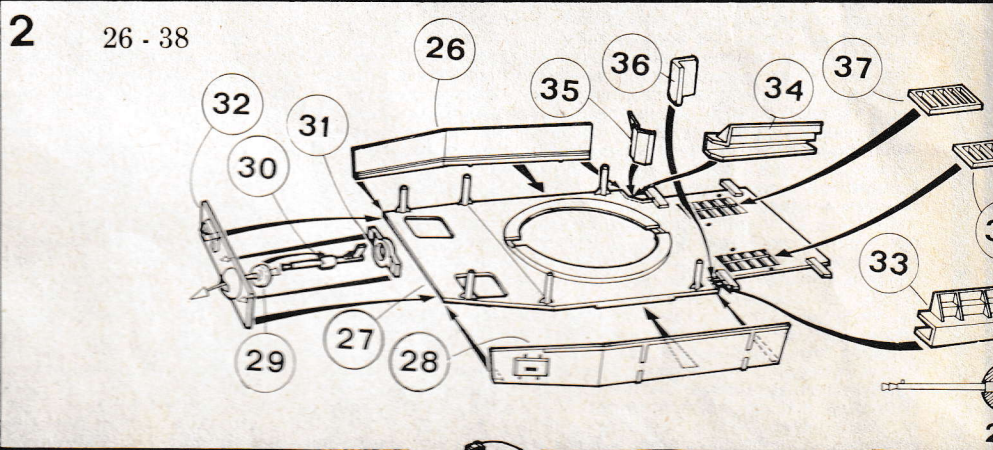
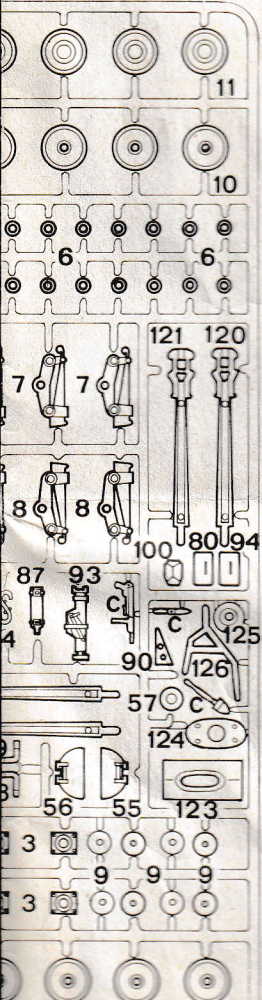
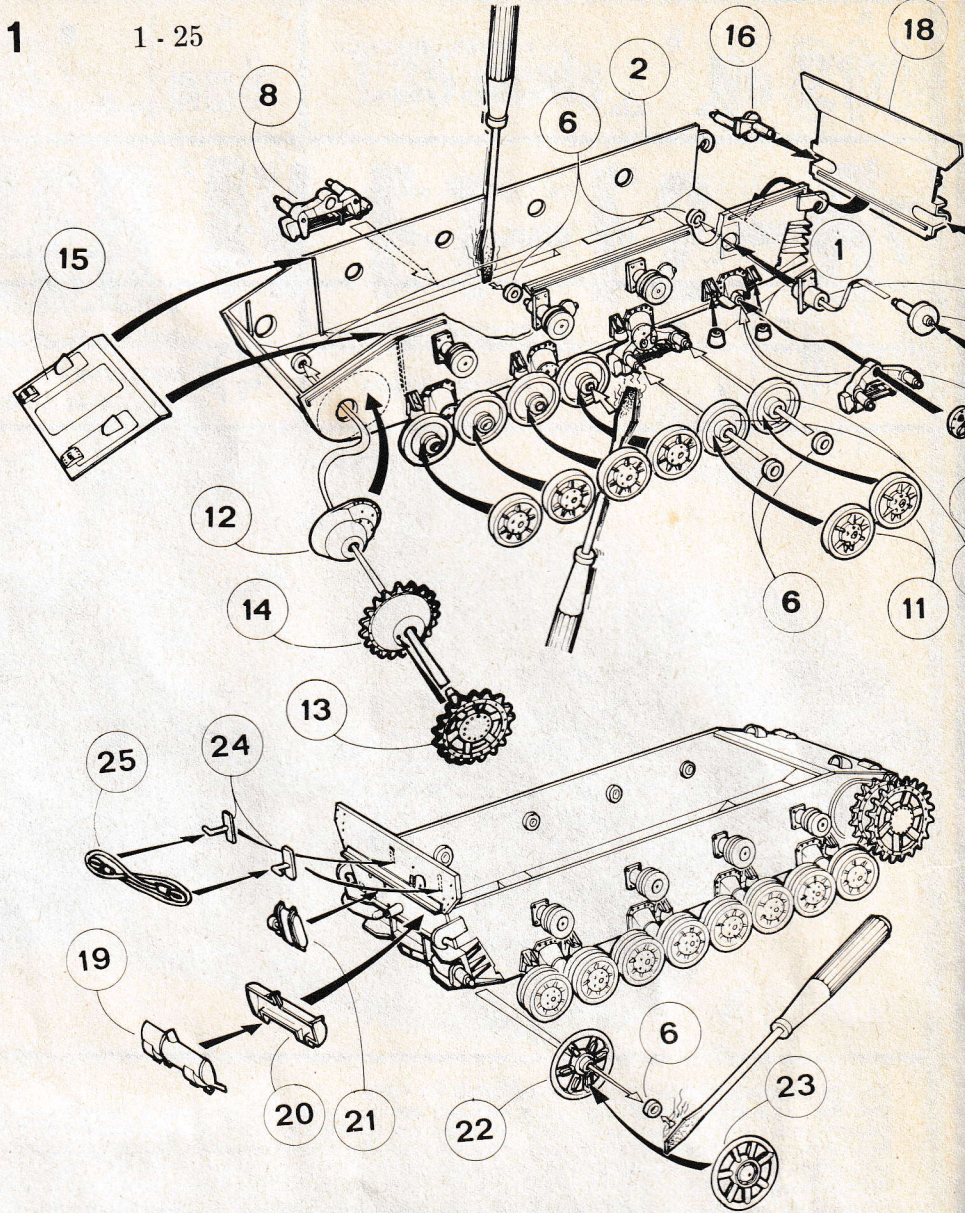
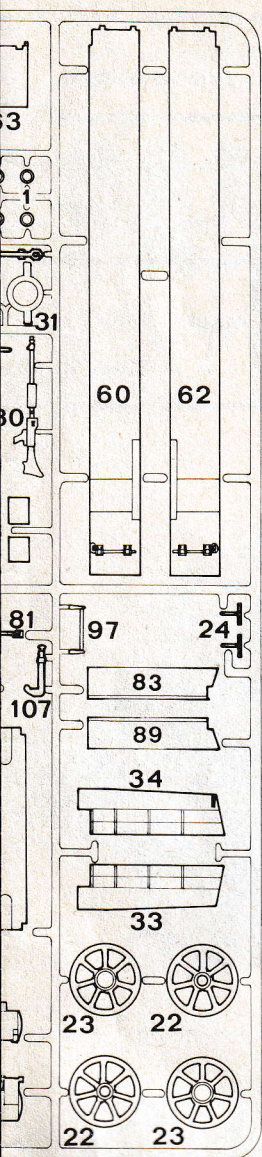

AT
AT
AC
42
NB: Per rea tagliar punto
To ma pieces shown

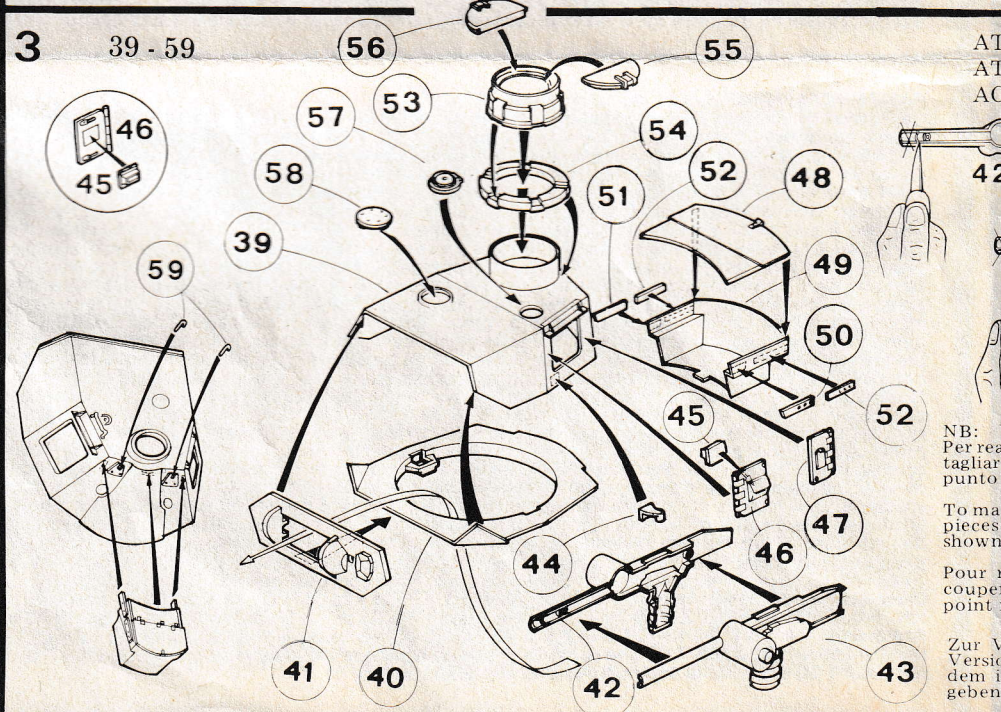
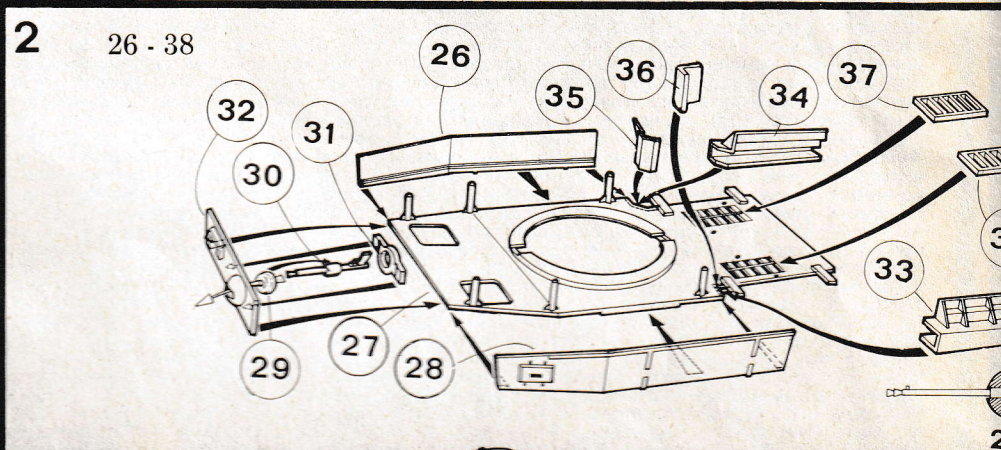
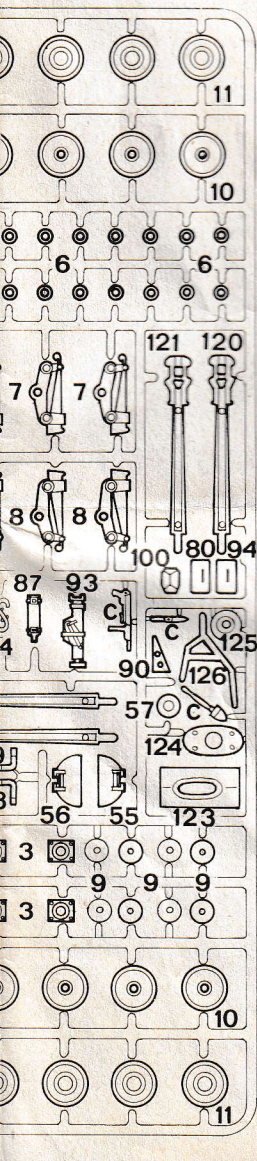
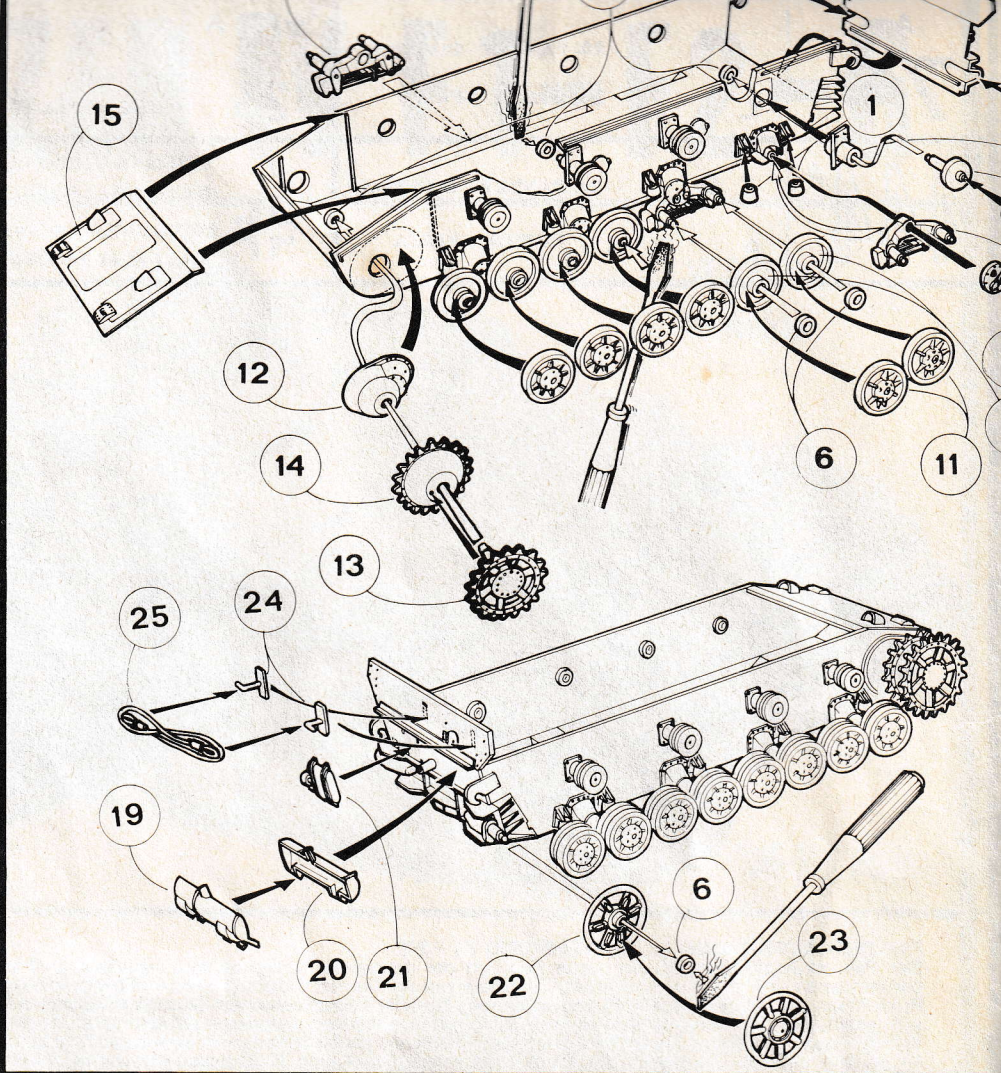
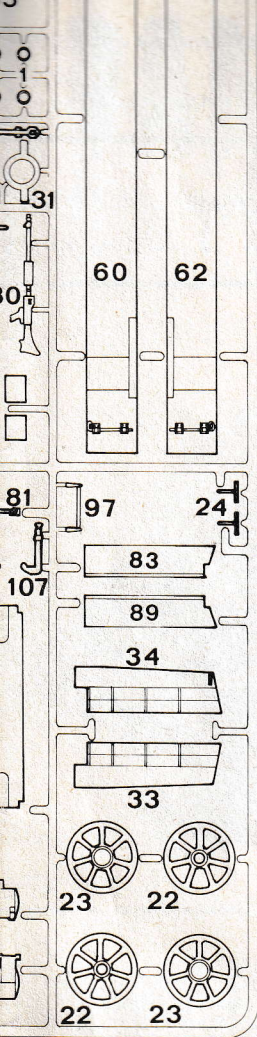

AT
AT
AC

NB:
Per rea
tagliar
punto

To ma
pieces
shown

Pour r
couper
point i

Zur V
Versic
dem i
geben

4 60 - 73

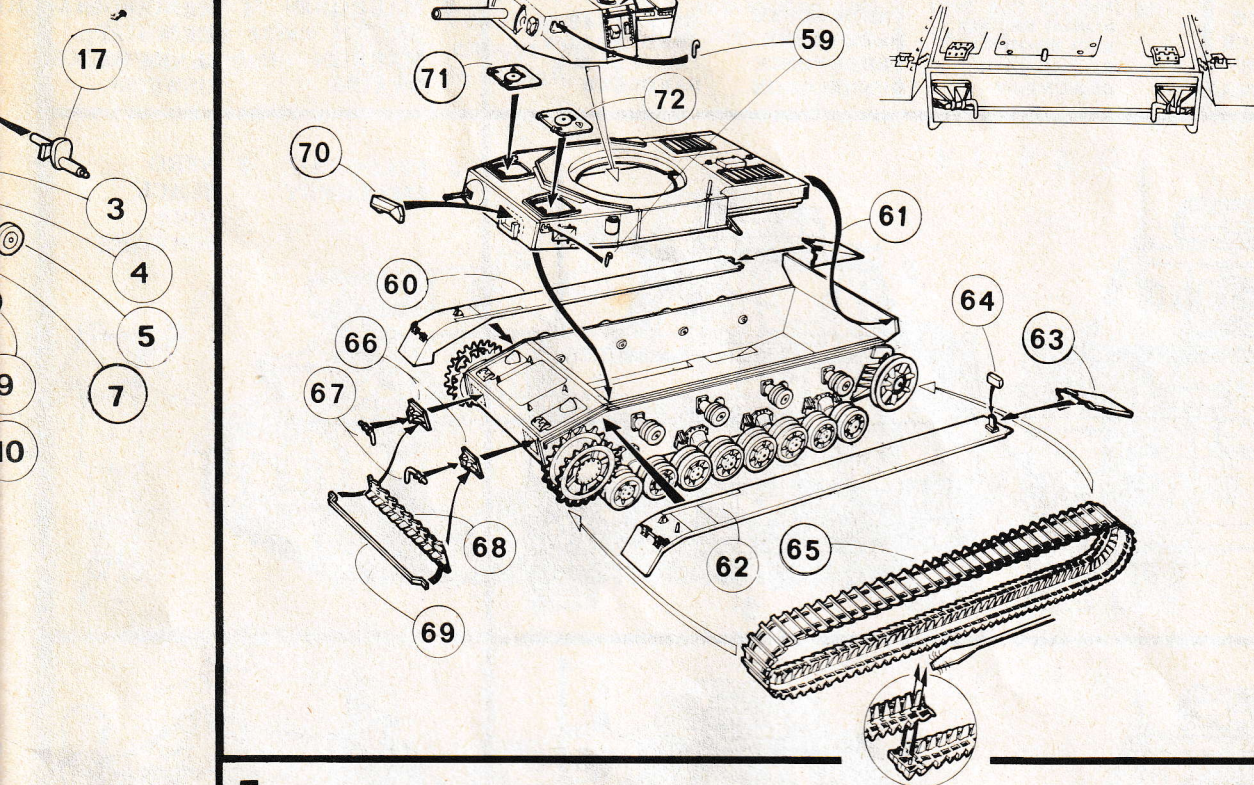

5 74 - 87

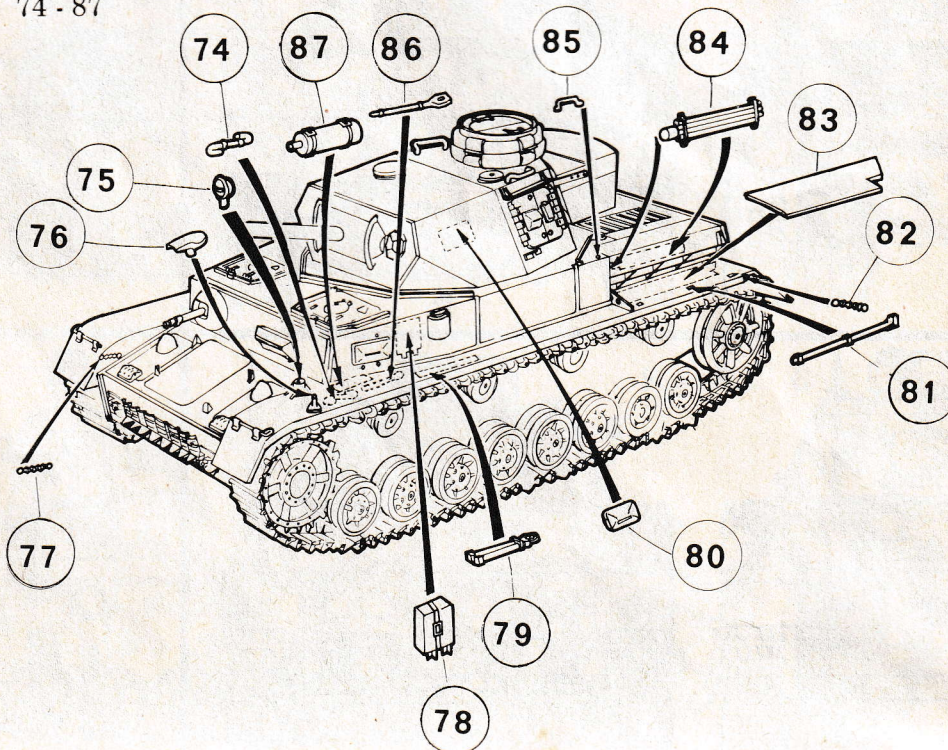

6 82 - 107

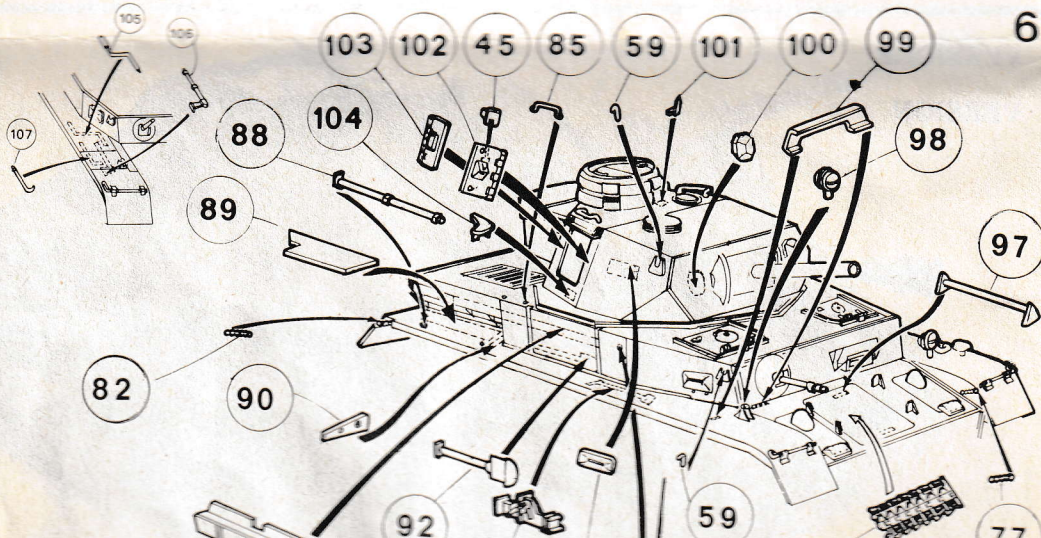

ATTENZIONE!
ATTENTION!
VORSICHTUNG!

Montare la versione F 1
nei pezzi 42 e 43 al
punto indicato nel disegno.

Mount the F 1 version cut
at points 42 and 43 at the point
indicated on the drawing.

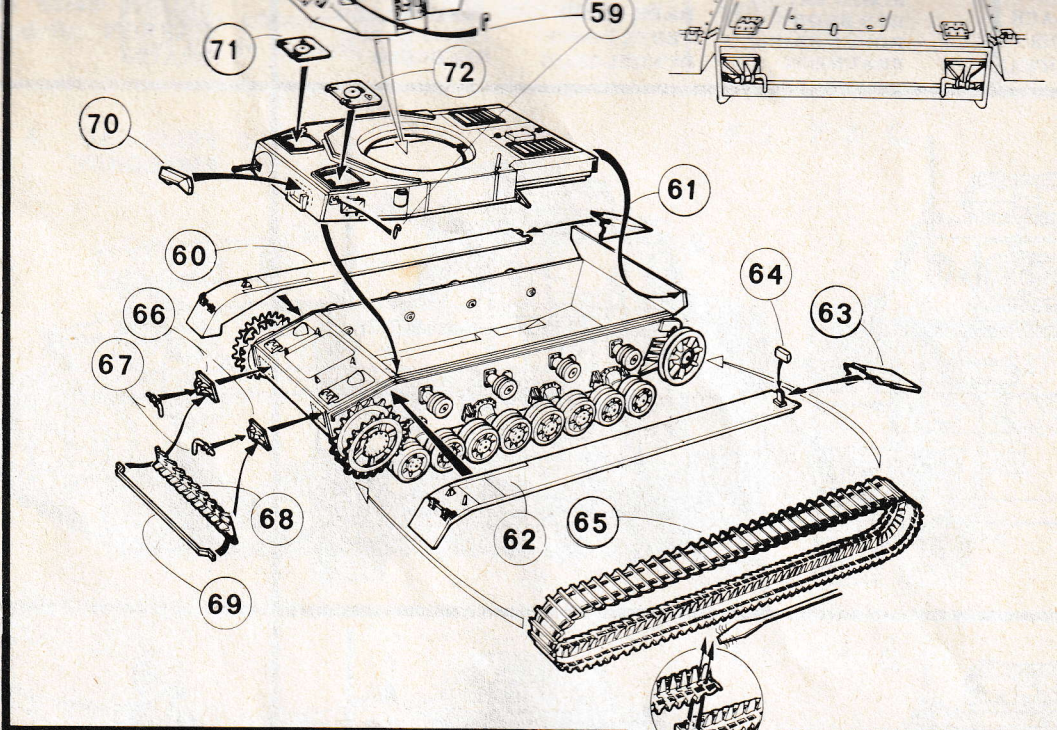
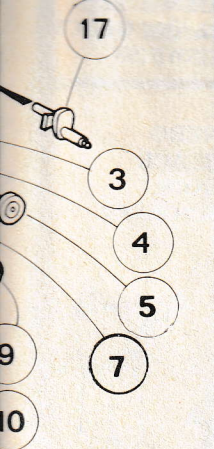

5 74 - 87

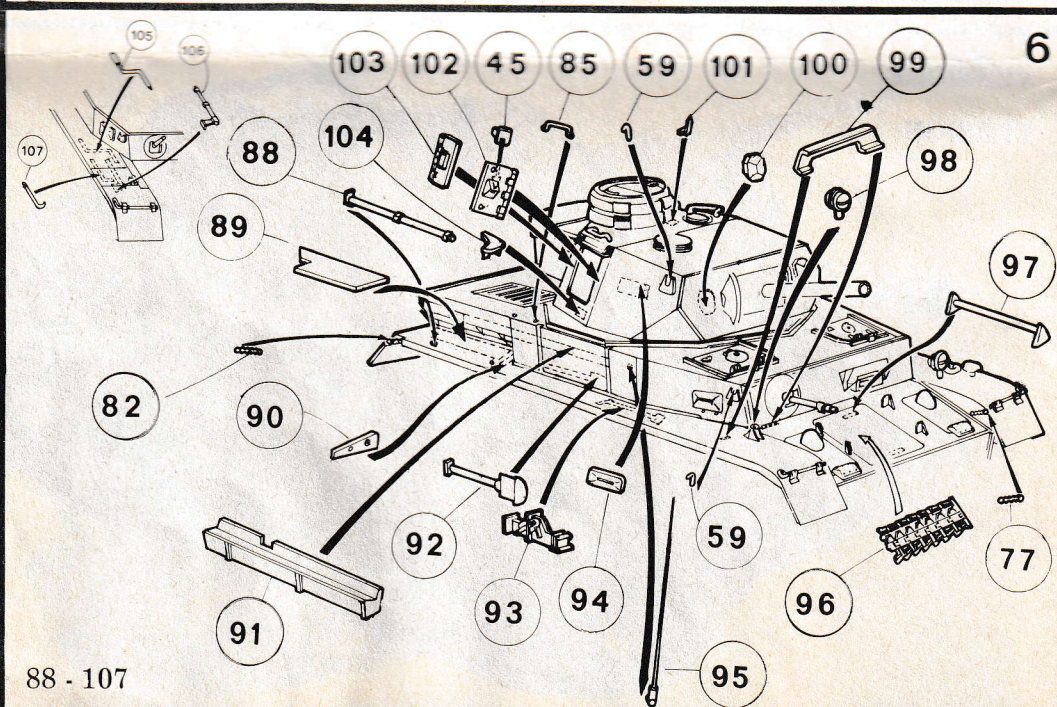
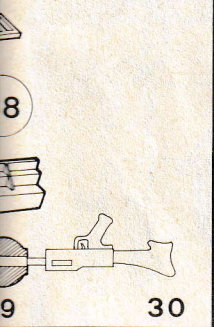
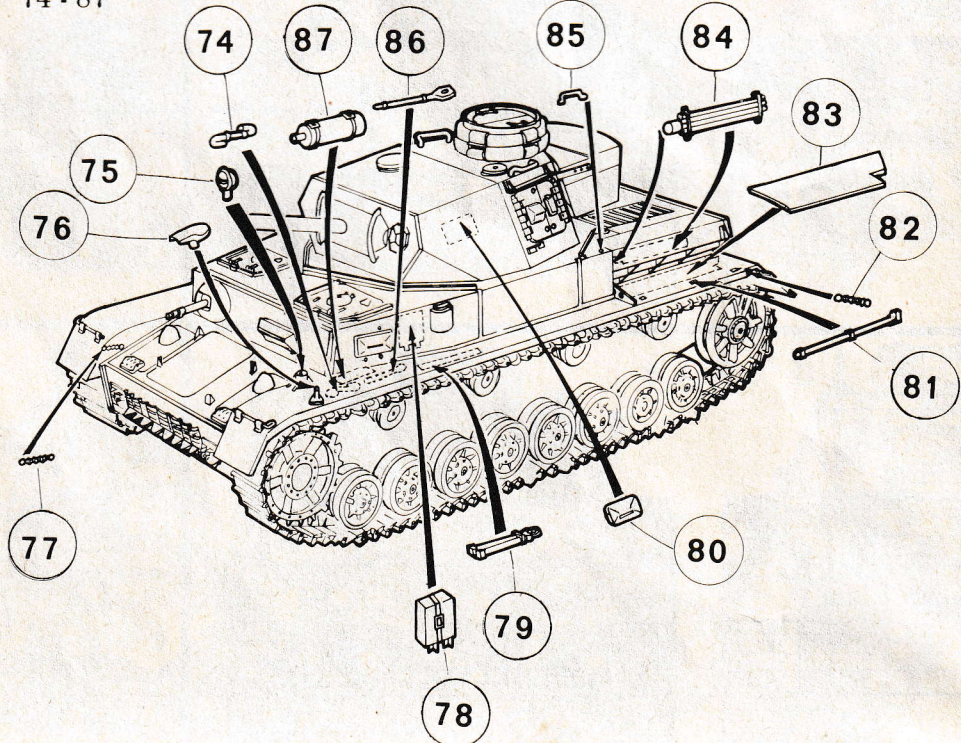

ATTENZIONE!
ATTENTION!
VORSICHTUNG!

Realizzare la versione F1
con i pezzi 42 e 43 al
punto indicato nel disegno.

Realiser la version F1
avec les pieces 42 et 43 au
point indique sur le dessin.

Realisierung der F1
mit den Teilen 42 und 43 an
der Zeichnung ange-
gebenen Punkt schneiden.

7. 108 - 119

VERSIONE F. 2
VERSION

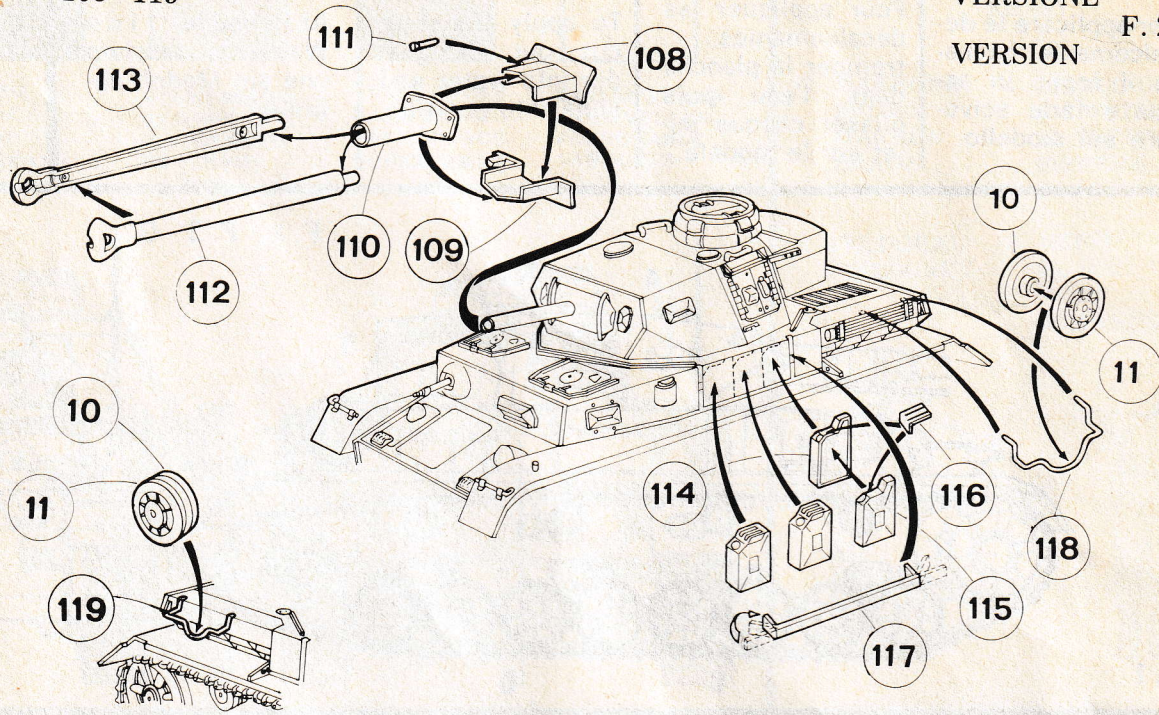

8. 120 - 122

VERSIONE G
VERSION

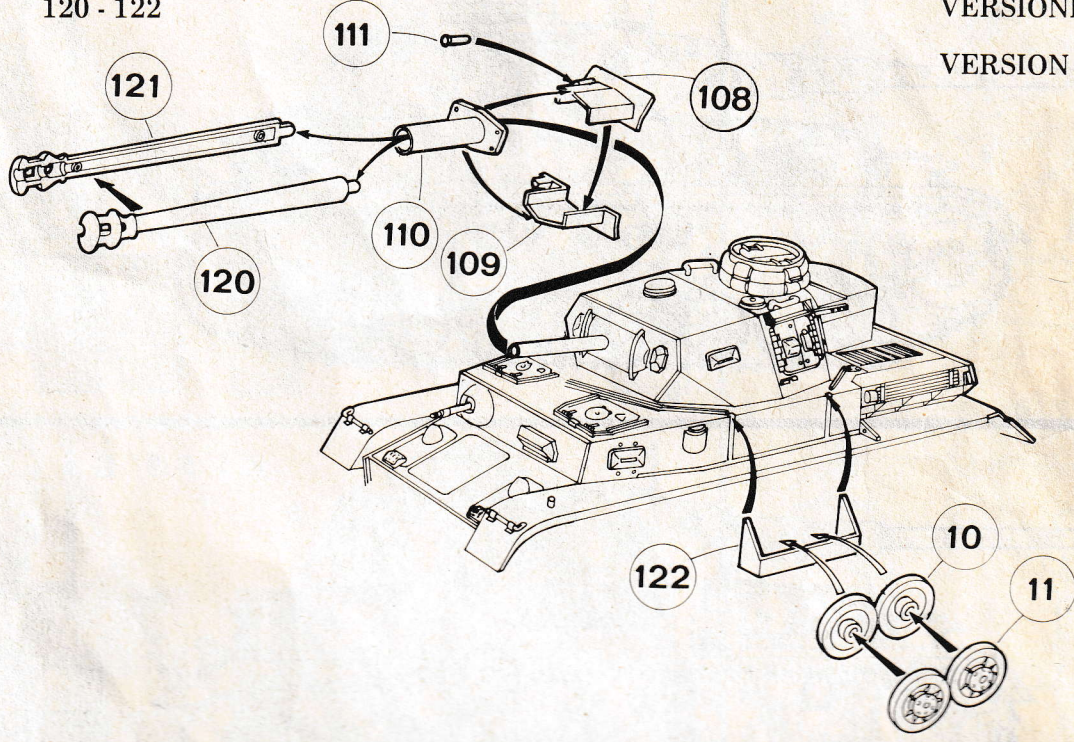

9. 123 - 126

VERSIONE F. 1
VERSION

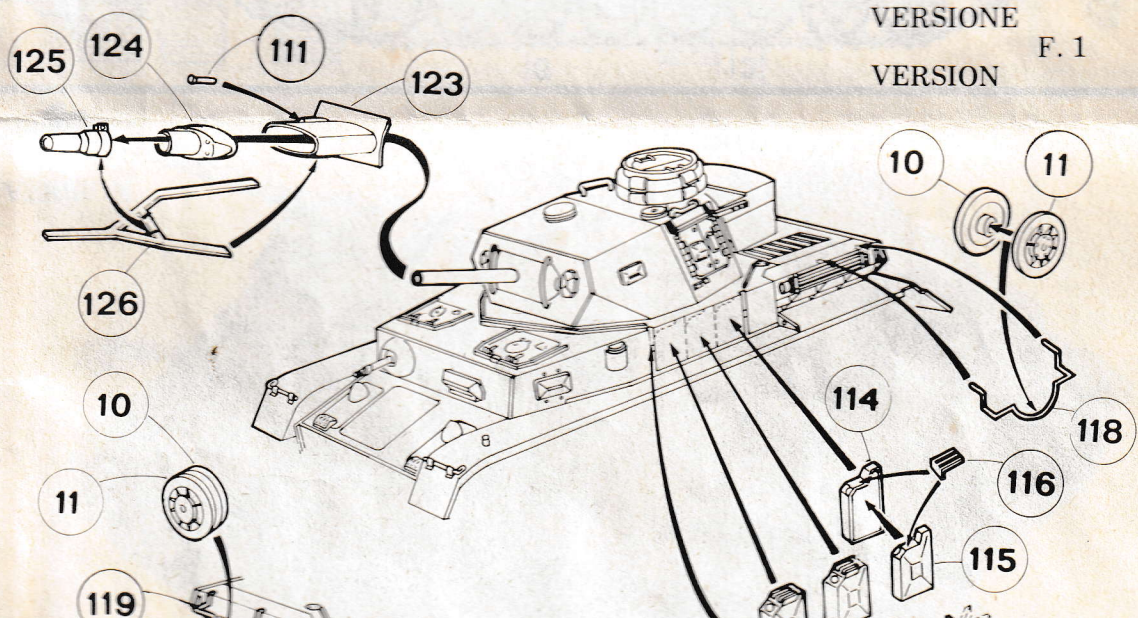

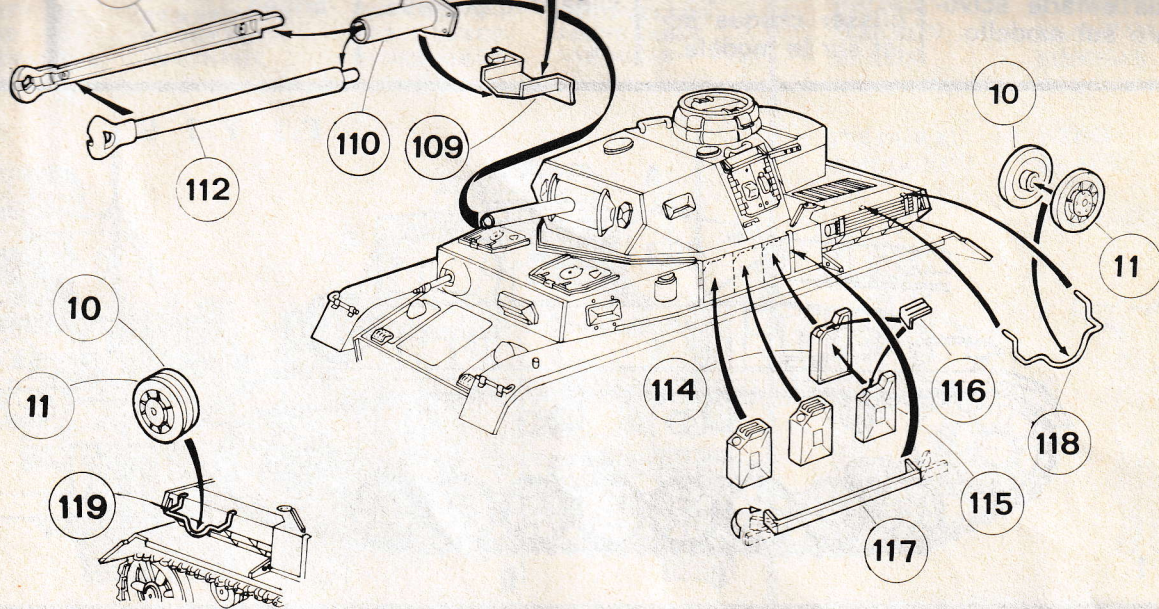

8

120 - 122

VERSIONE G
VERSION

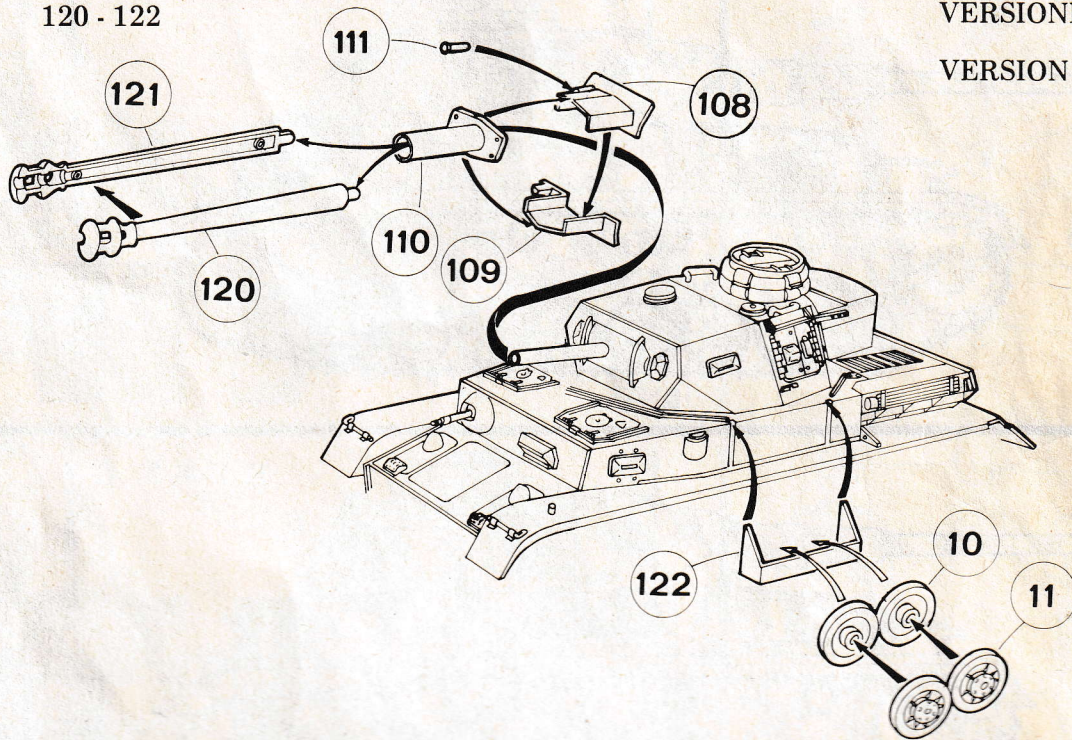

VERSIONE F. 1
VERSION

9

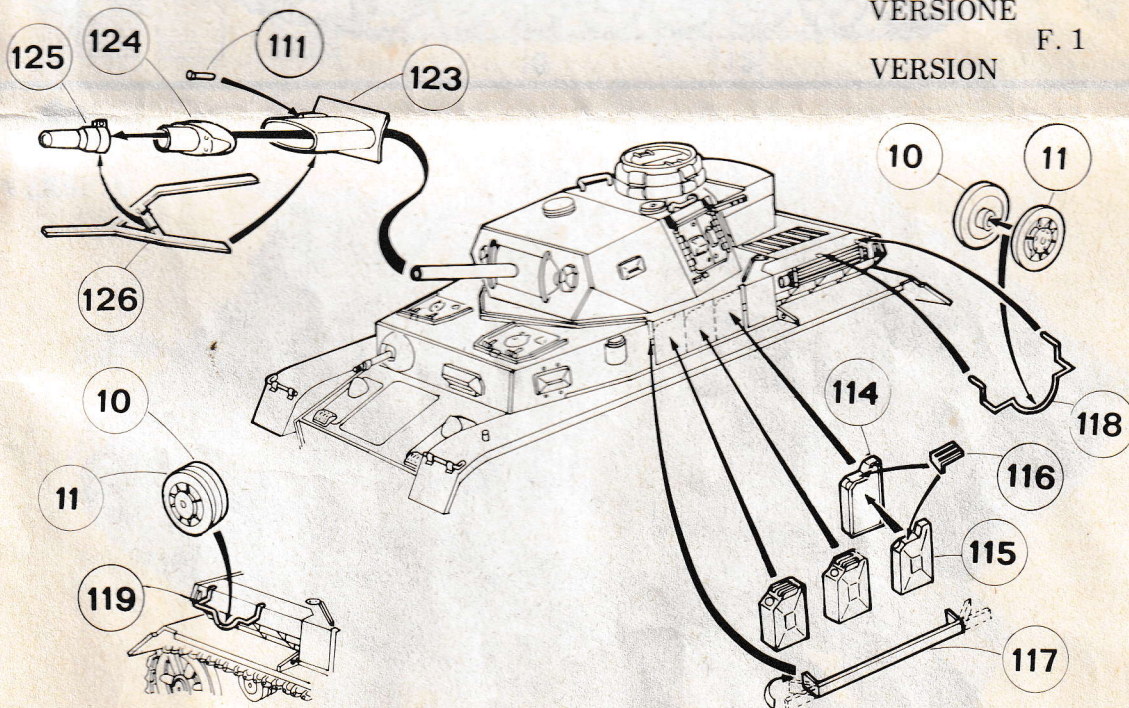

123 - 126

Per applicare le decalcomanie bagnare il foglio in acqua e farle scivolare sul modello.

Pour appliquer les décalcomanies tremper la planche dans l'eau puis glisser chaque sujet sur le modèle.

To apply transfers cut out designs, dip into water and slide into position.

Abziehbilder in's Wasser tauchen und am Modell anbringen.

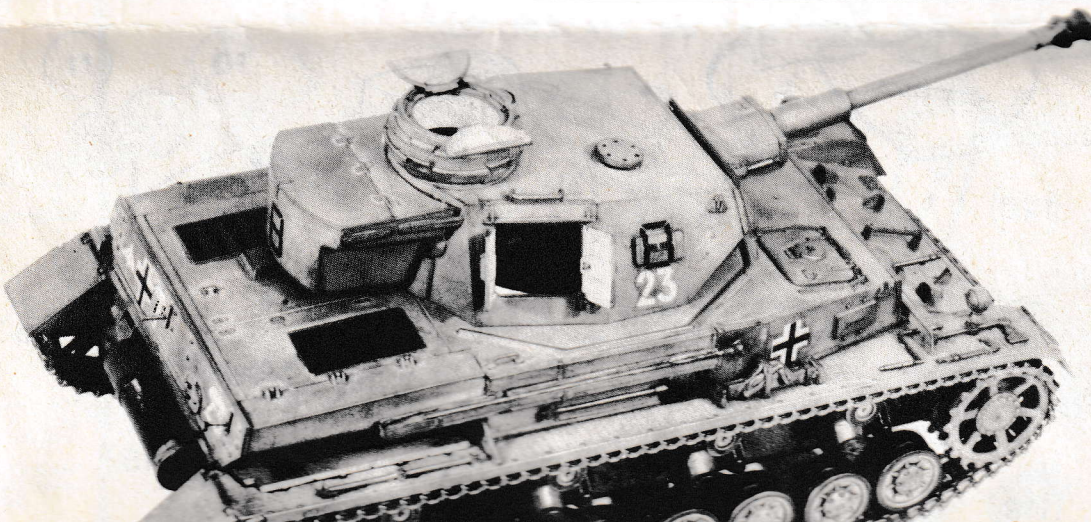
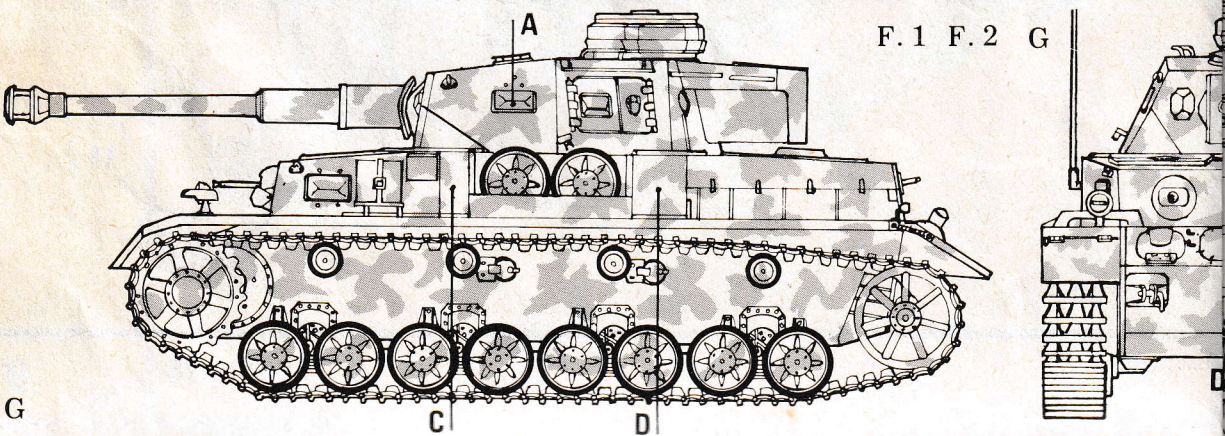
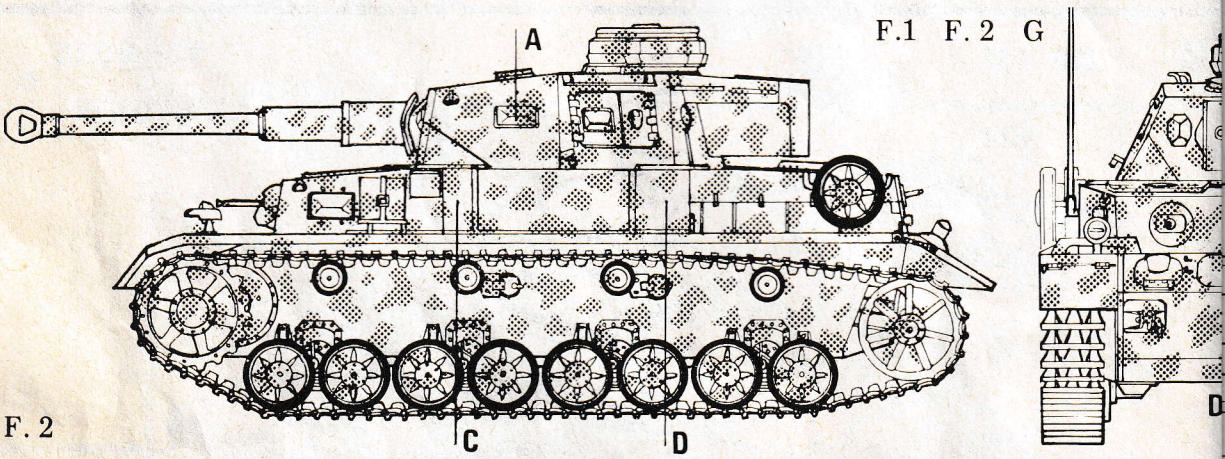
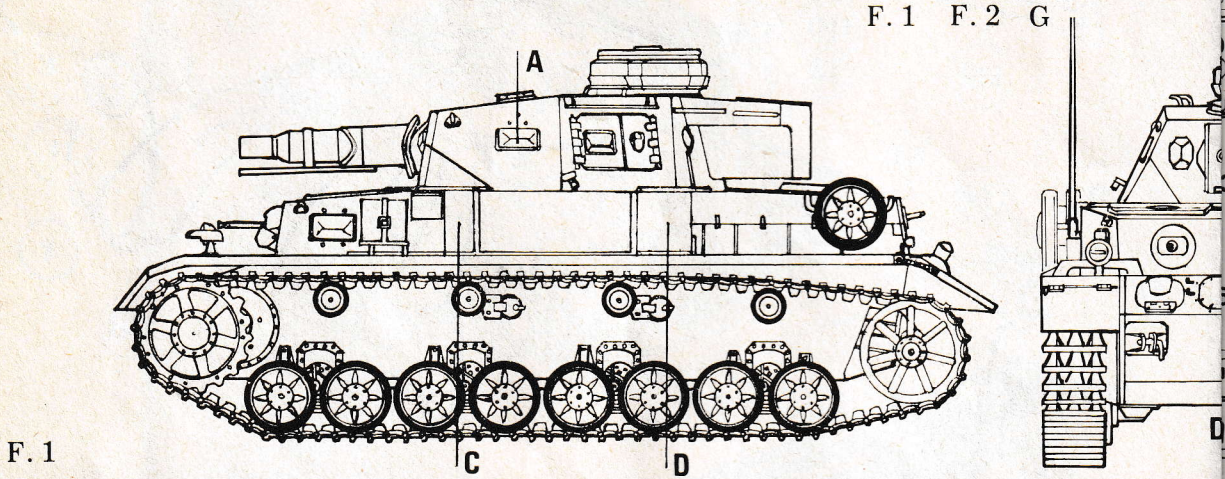

qua e l'aria scivola-
lare sul modello.

glisser chaque su-
jet sur le modèle.

slide into position.

origen.

F.1 F.2 G

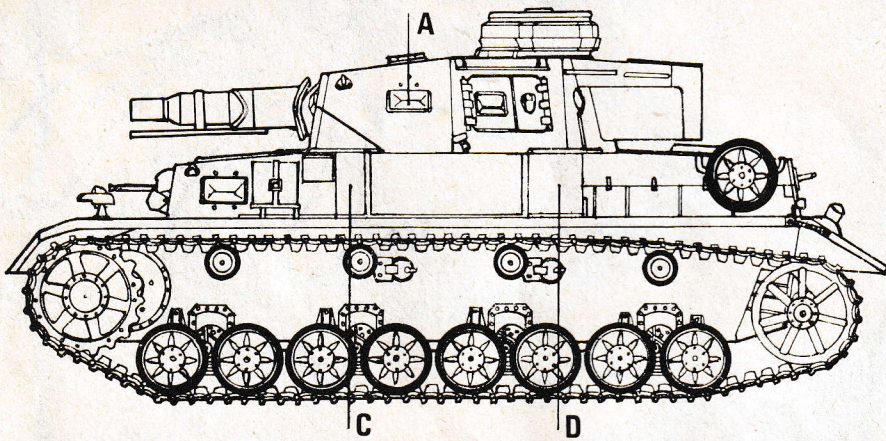

F.1

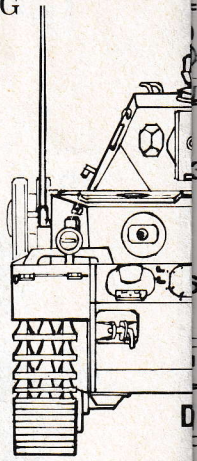

F.1 F.2 G

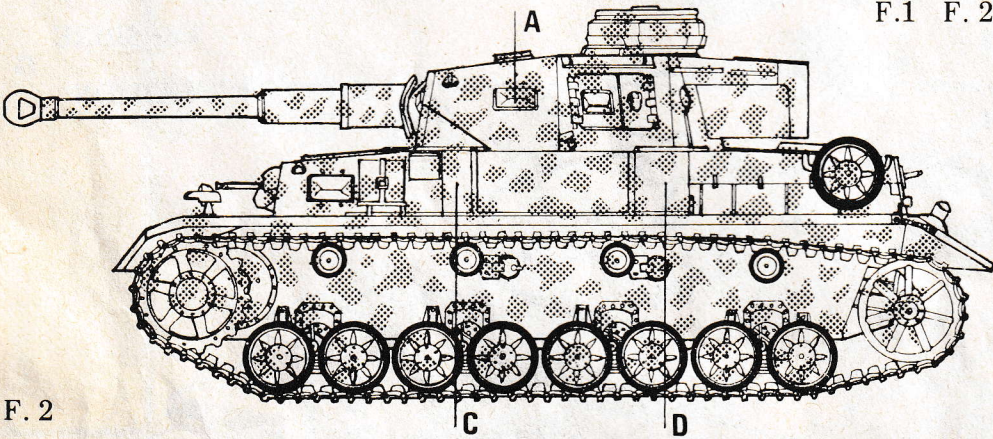

F.2

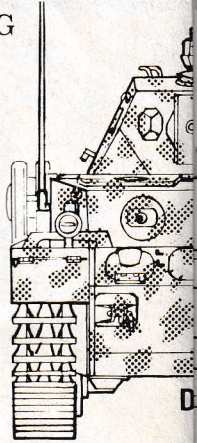

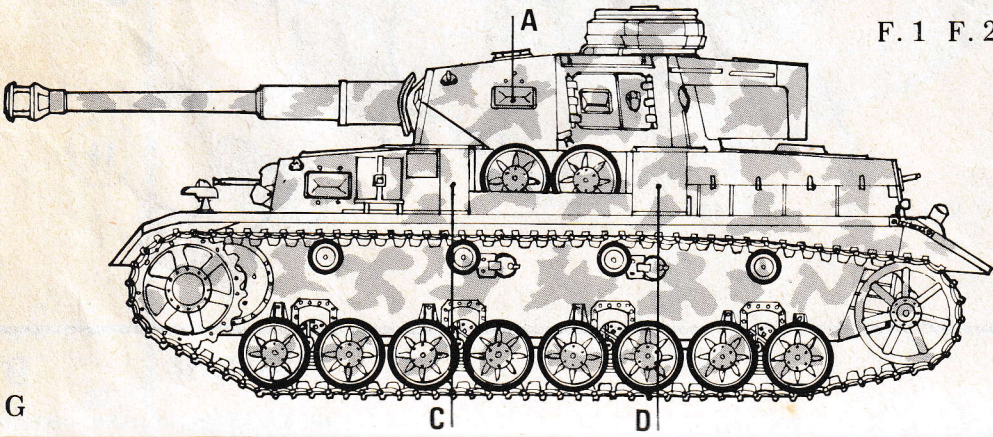

F.1 F.2 G

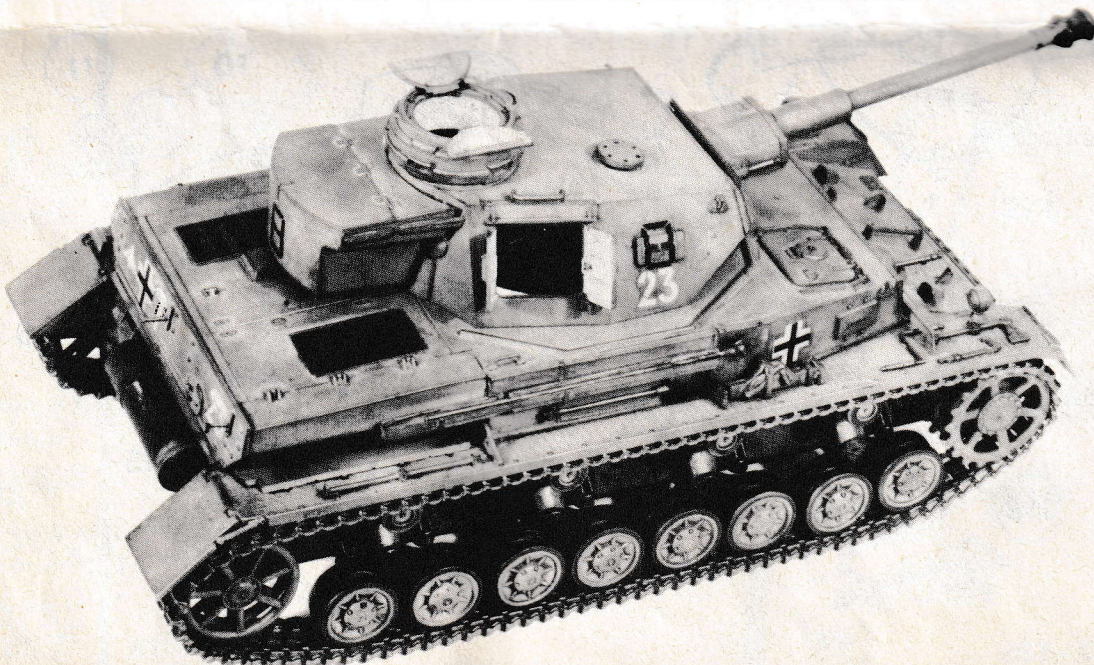
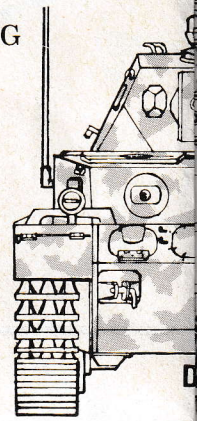

G

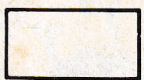

| | | | |
|--|--|--|--|
|  |  |  |  |
| NERO BLACK NOIR SCHWARZ | ROSSO BRUNO RED BROWN ROUGE BRUN BRAUNROT | VERDE SCURO DARK GREEN VERTE FONCE DUNKELGRÜN | GIALLO SABBIA SAND YELLOW JAUNE SABLE SANDGELB |

- 1 KAKI
KHAKI
- 2 MARRONE
BROWN
MARRON
BRAUN
- 4 BIANCO GHIACCIO
ICE WHITE
BLANC GLACE
EISWEISS
- 3 FELDGRAU
FIELDGREY
- 5 NERO
BLACK
NOIR
SCHWARZ

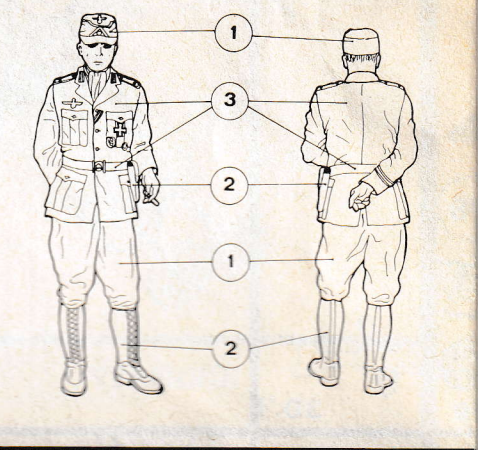
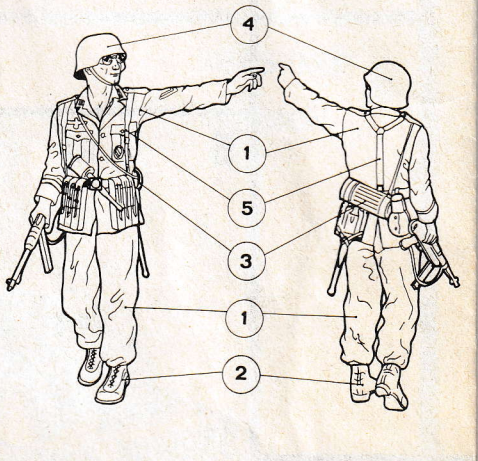
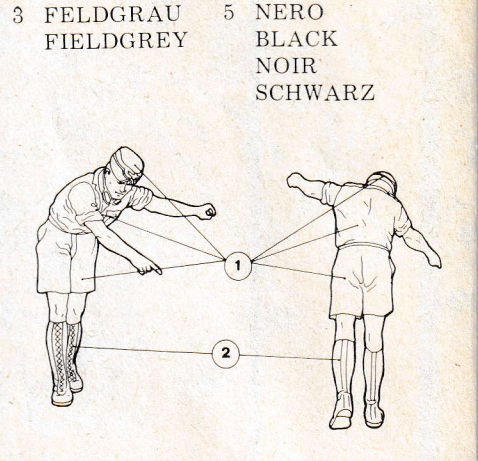
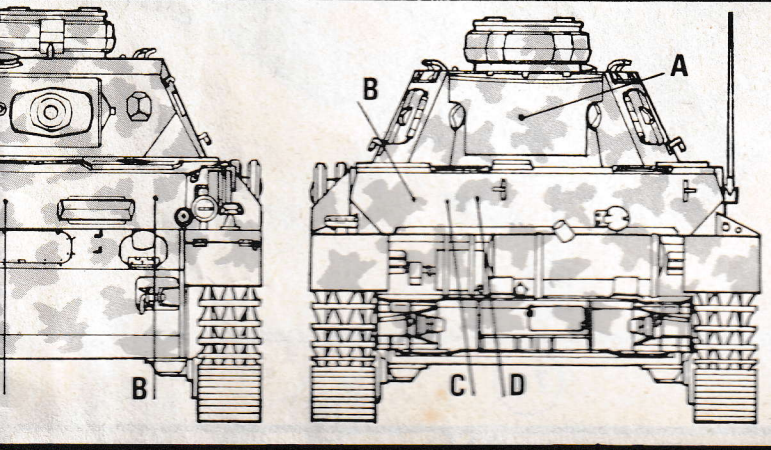
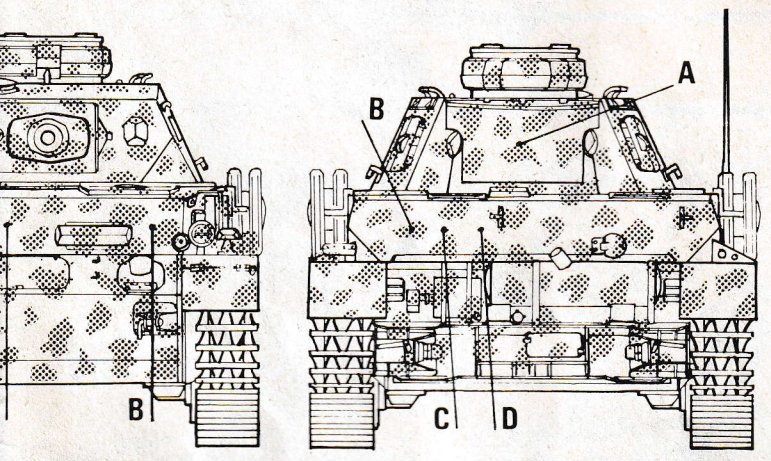
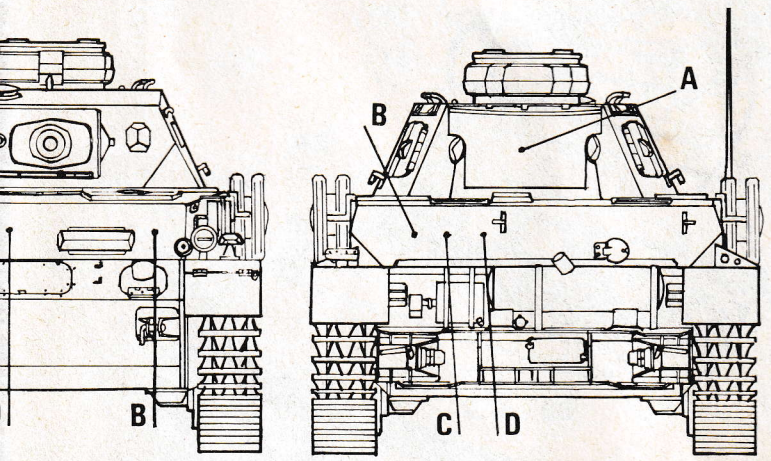

VERSIONE G
VERSION

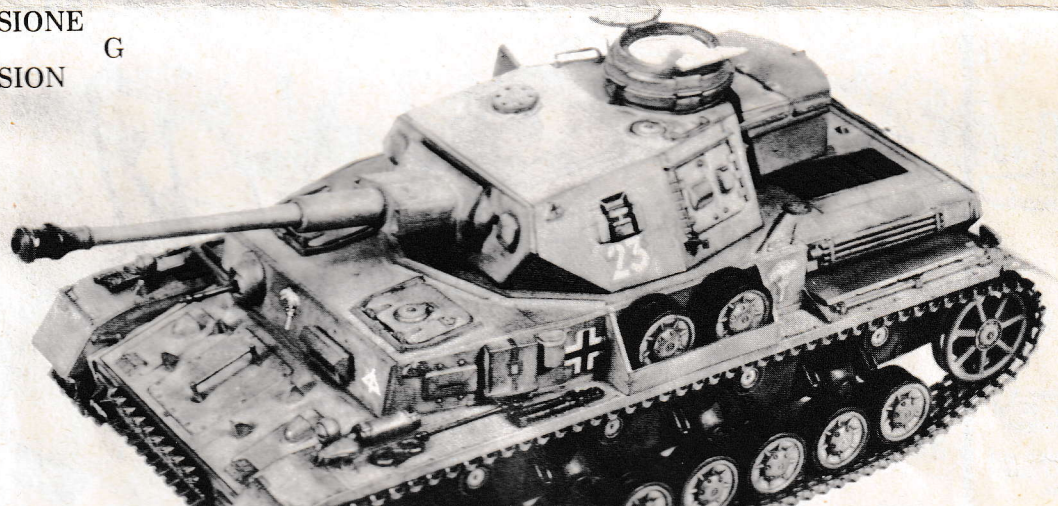

BLACK
NOIR
SCHWARZ

RED BROWN
ROUGE BRUN
BRAUNROT

DRK GREEN
VERTE FONCE
DUNKELGRÜN

SAND YELLOW
JAUNE SABLE
SANDGELB

BROWN
MARRON
BRAUN

ICE WHITE
BLANC GLACE
EISWEISS

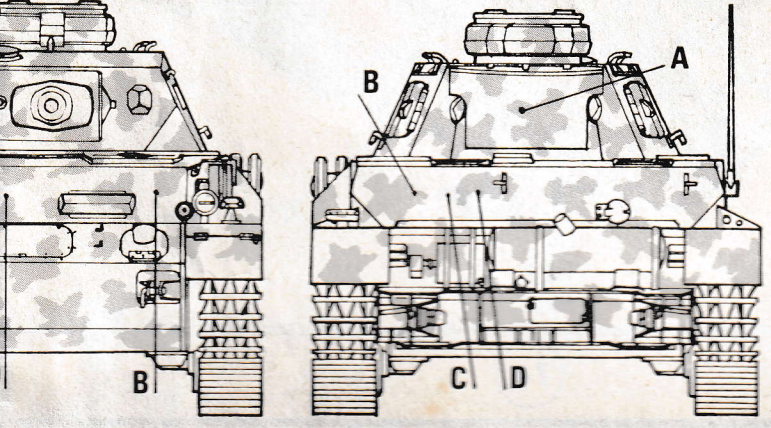
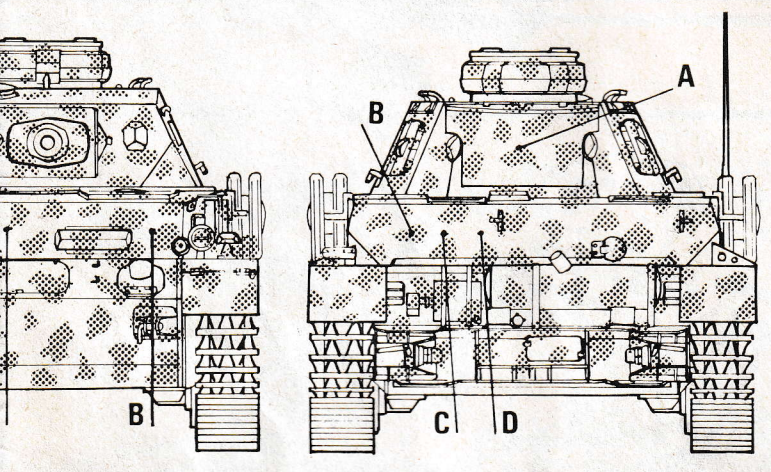
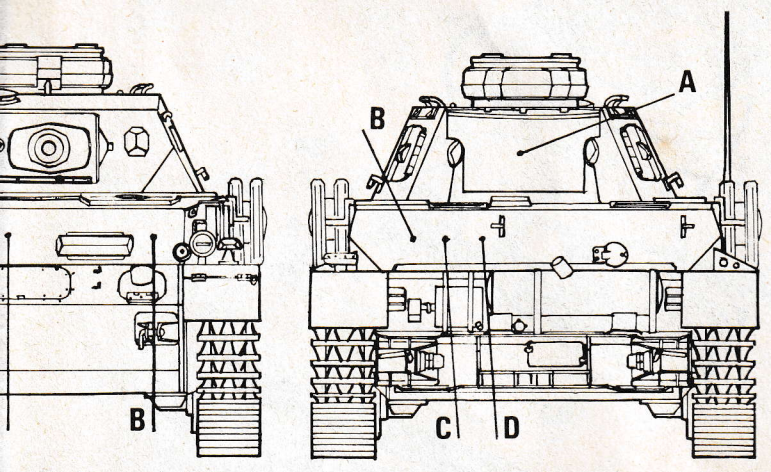

3 FELDGRAU
FIELDGREY

5 NERO
BLACK
NOIR
SCHWARZ

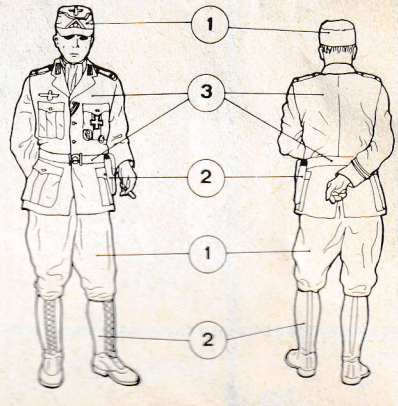
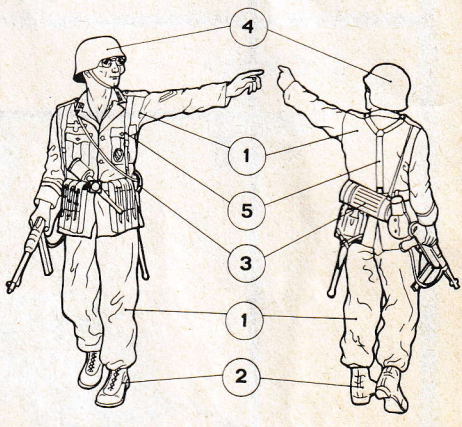
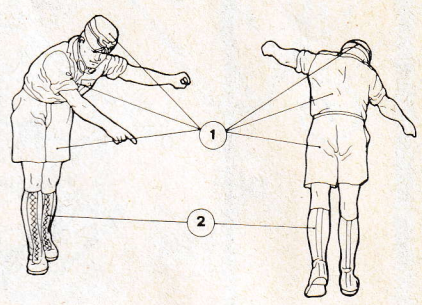

VERSIONE G
VERSION

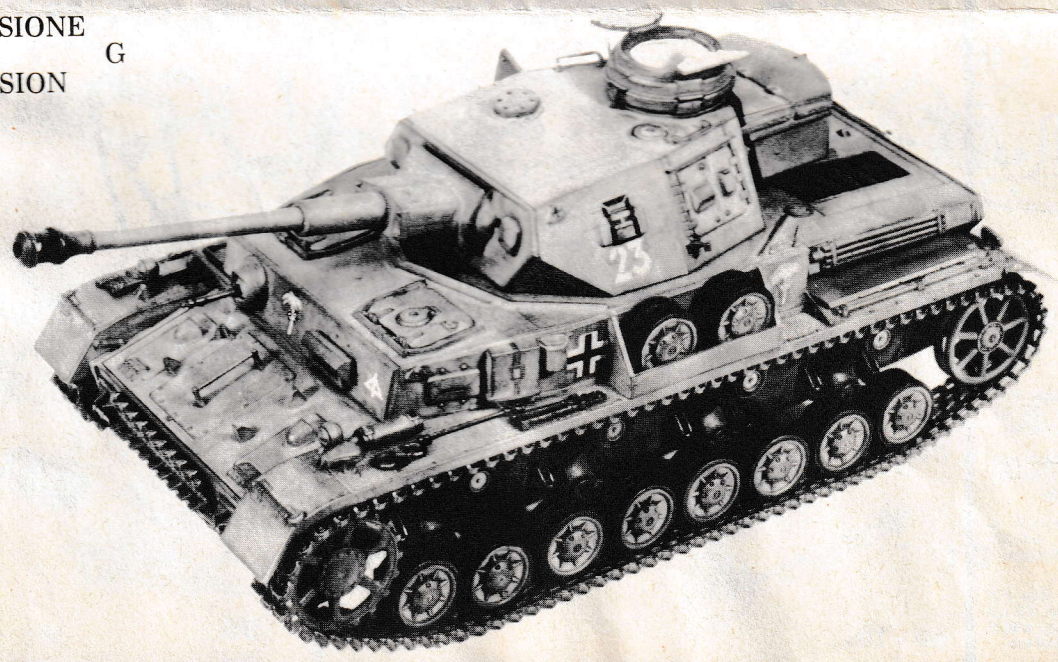

| | | | | | |
|----|----------|--|---|-------------------|--|
| F1 | A 413 | B 15. PANZER - DIVISION NORTH AFRICA | G | A 408 | B 21. PANZER - DIVISION NORTH AFRICA |
| F2 | A 7♠ | B 10. PANZER - DIVISION NORTH AFRICA | G | A 823 | B 15. PANZER - DIVISION NORTH AFRICA |
| F2 | A 444 | B 21. PANZER - DIVISION NORTH AFRICA | C INSEGNA NAZIONALE NATIONAL SIGN ENSEIGNE NATIONALE NATIONAL-ZEICHEN | D AFRIKA KORPS | |

VERSIONE

F. 2

VERSION

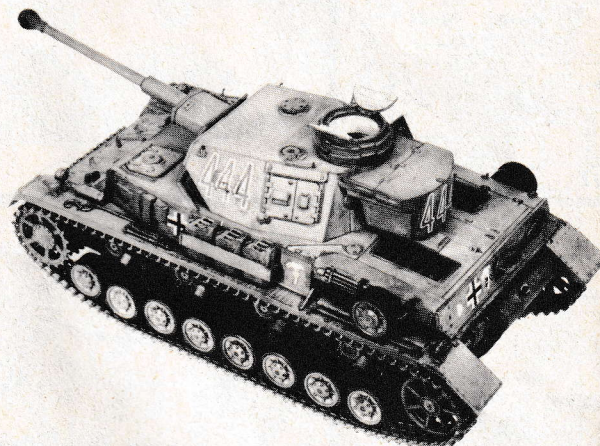
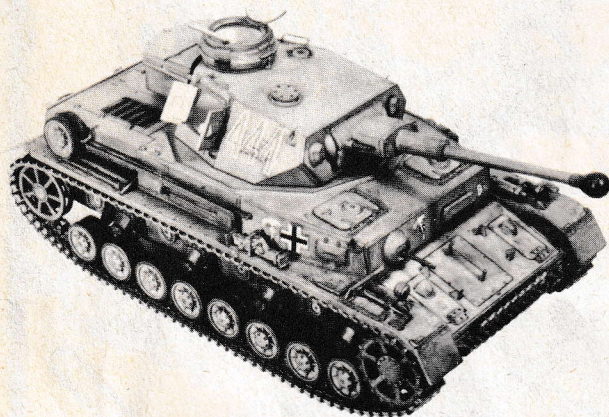

PANZERKAMPFWAGEN IV, AUSFÜHRUNG F1 F2/G

Der Panzerkampfwagen IV war unter den von der deutschen Kriegsindustrie hergestellten Panzern sicherlich einer der berühmtesten und meist verwendeten. Trotzdem war im Februar 1943 das Heer im Begriff, diesen Typ einzuziehen, um der Produktion der TIGER-Panzer Platz zu machen. Nur die Entschlossenheit Guderians konnte einen Stopp der Produktion vermeiden, die der Wehrmacht eine ihrer leistungsfähigeren und vielseitigen Waffen in einer der Entscheidungsphasen des Krieges genommen hätte. Dieser Panzer entstand 1934 aus der Notwendigkeit über einen Typ zu verfügen, der den Standard III stützen konnte. Die eigentliche Produktion wurde von Krupp 1936 begonnen und am Ende des Krieges mit ca. 9000 erzeugten Einheiten abgeschlossen, die 10 verschiedenen Ausführungen herausgebracht, nach und nach verbessert und leistungsgesteigert wurden. Unter diesen die Versionen A-B-C-D-E-F1, bei denen eine 75 mm-Kanone L 24 mit kurzem Rohr untergebracht war. Der Bausatz enthält die Version F1 mit kurzem Rohr und die Versionen F2 - G, bei denen man zum ersten Mal eine Kanone mit längerem Rohr einbaute. Die Version F2 hat sich als notwendig erwiesen, um den neuen Panzern und den immer leistungsfähiger werden Panzerabwehrwaffen, mit denen die Gegner Deutschlands ausgestattet waren, standzuhalten. Bereits ab November 1941 verlangte man für den Panzer IV eine Kanone mit langem Rohr. Das schliesslich ausgewählte Modell 75 L 43, wurde ab Anfang 1942 installiert und erlaubte eine schnellere und geradlinigere Geschossbahn. Diese version, "Ausführung F2" genannt, war an der typischen kugelförmigen Mündungsbremse der Kanone erkennbar. Auch im Modell G wurde das gleiche Stück eingebaut, nur mit einer Doppelmündungsbremse ausgerüstet stellte dieses im wesentlichen das Ergebnis aller bei der vorhergehenden Serie vorgenommenen Änderungen dar. Der Rumpf des Panzers IV bestand aus geschweissten Platten und war in drei Zellen eingeteilt: Vorne der Führerraum, in der Mitte der Kampfraum mit den Kraftstofftanks an der Unterseite und hinten die Antriebsgruppe - bestehend aus einem Maybach-Motor HL 120 TRM mit 11867 cm³ Inhalt. Die Fortbewegung war auf einer Seite von vier Rollstellen mit zwei Doppelwalzen gesichert, mit gummierter Aussenseite und Blattfederaufhängungen, vier Walzen zum Halten der Raupen, Vorderantriebsrädern und Hinterrichtung. Am Beginn der Operationen in der Tschechoslowakei und des Feldzuges in Polen rüstete der Panzer IV die vierte Kompanie jedes Panzerbataillons aus, nachher gehörte er zu der Unterstützungskompanie, im direkten Dienste des Bataillonskommandos. Mit Beginn des "Barbarossa" Unternehmens zeigte sich der Panzer III als überholt und das Modell IV, im Schutz und in der Bewaffnung nach und nach abgeändert - war das Rückgrat der Panzerbataillione. Der Panzer IV zeichnete sich auf allen Kriegsschauplätzen des 2. Weltkrieges aus: Von Afrika, wo er ein gefürchteter Gegner der britischen Truppen war, bis Russland, wo er den übermächtigen Panzern und Panzerabwehrwaffen der Roten Armee kräftig standhalten konnte. In der jüngsten Zeit hat der Panzer IV nochmals seine Stärke gezeigt, indem er von Syrien 1956 bei dem kurzen Krieg gegen Israel eingesetzt wurde. **Eigenschaften:** Benennung: Pz Kpfw Ausf. F1 - F2 (Sd Kfz 161) G (Sd Kfz 161/1) Besatzung: 5 Mann Gefechtsgewicht: F1 22300 kg F2 - G 23600 kg - Max. Länge: F1 5,93 m F2-G 6,63 m Max. Breite: 2,88 m - Max. Höhe: 2,68 m Bewaffnung: F1 7,5 L 24 KwK F2-G 7,5 L 43 (KwK 40) im Drehturm mit 80 Schuss F1 und 87 Schuss F2-G - Höhenrichtung: + 20° - 10° 2 MG 7,92 davon eines koaxial und eines in Kasematte - Max. Geschwindigkeit: auf der Strasse F1 42 km/h F2-G 40 km/h auf unebenem Gelände: F1 20 km/h F2-G 16 km/h - Fahrbereich: 200/130 km.

PANZERKAMPFWAGEN IV AUSFÜHRUNG F1 F2/G

Le Panzerkampfwagen IV est certainement l'un des chars les plus fameux et les plus employés parmi ceux produits par l'industrie de guerre allemande. Malgré cela, en février 1943, il allait être déclassé pour laisser place à la production du char TIGRE et seule l'intervention énergique de Guderian empêcha l'arrêt de sa construction qui aurait privé la Wehrmacht d'une de ses armes les plus puissantes et les plus polyvalentes à l'un des moments les plus critiques de la guerre. Il naquit en 1934 de la nécessité de disposer d'un char pour appuyer le type standard III. Sa véritable production fut commencée par Krupp en 1936 et elle se termina à la fin de la guerre avec environ 9.000 unités produites, réparties en 10 versions différentes, peu à peu améliorées et renforcées; parmi celles-ci les A-B-C-D-E-F 1 étaient équipées d'un canon à tube court de 75 L 24. La boîte contient la version F1 à tube court et les versions F2 - G qui furent les premières à être équipées d'une pièce à tube plus long. La version F2 fut imposée par le besoin de faire face aux nouveaux chars et aux armes antichar toujours plus puissants dont étaient équipés les adversaires de l'Allemagne. Déjà dès novembre 1941 on avait demandé pour le Panzer IV une arme à long tube et la pièce choisie fut le 75 L 43 qui fut installé durant les premiers mois de 1942 et qui permettait un tir plus tendu et plus rapide. Cette version fut appelée AUSFÜHRUNG F2 et on pouvait la reconnaître à son frein de bouche typique, à forme de globe. Le modèle G aussi avait la même pièce, munie maintenant d'un double frein de bouche et il était, en définitive, le résultat de toutes les améliorations introduites dans la série précédente. La coque du Panzer IV était constituée par des plaques soudées et elle était divisée en trois compartiments dont l'antérieur abritait le conducteur, le central, la chambre de combat avec les réservoirs de carburant dans la partie basse, le postérieur, le groupe propulseur qui était un MAYBACH HL 120 TRM de 11867 cm³. De chaque côté le roulement était assuré par quatre chariots de deux rouleaux doubles, capotoutés à l'extérieure, avec des suspensions à ressort, quatre rouleaux porte-chenille, des roues motrices antérieures et de tension postérieures. Au début, lors des opérations de Tchécoslovaquie et pendant la campagne de Pologne, le char modèle IV équipait la quatrième compagnie de chaque bataillon blindé; puis, il fit partie de la compagnie lourde d'appui, sous la dépendance directe du commandement de bataillon. A partir de l'opération Barbarossa, le char modèle III s'avéra dépassé et le modèle IV, peu à peu modifié dans la protection et dans l'armement, équipa la plupart des bataillons blindés. Ce char put se distinguer sur tous les théâtres d'opération de la IIème guerre mondiale: de l'Afrique, où il fut un terrible adversaire pour le détachement anglais, jusqu'à la Russie, où il affronta avec succès les puis-