

BONUS は十分に
つくした
Figure Included

cyber-hobby.com

©小林英文 / motofumi kobayashi

Project supervised by HIROHISA TAKADA. Technical drawings provided by MINORU IGARASHI.
Thanks to TOM COCKLE and GARY EDMUNDSON as Technical Consultants.

KIT NO. 6662

Ax2 **Bx2** **C** **Gx3**

D **N** **K** **TA** **TB**

TH **TJ** **TG**

O **L** **J** **TK**

S **U** **W** **I** **MA** (Photo-etched Parts)

Yx120 **Zx120**

MB (Metal Parts)

MagicTrack
PATENT REGISTERED
実用新案登録済み

の部品は使用しません
Parts not for use.
Telle werden nicht verwendet.
Pieces a ne pas utiliser.
Parti nin utilizzati.
不需要使用的部件

x2
2つ製作してください
MAKE 2PCS
2 TEILE FERTIGEN
EFFECTUER 2 PIECES
FAIRE DUE PEZZI
TEE 2 KPL
GOR 2 ST
製作二組

切り取ってください
REMOVE
ENTFERNEN
RETIRES
SEPARARE
POISTA
AVLAGSNA
切去

接着しないでください
DO NOT CEMENT
NICHT KLEBEN
NE PAS COLLER
NON INCOLLARE
EILIJÄÄ
LIMMAEJ
不用黏合

デカールを貼ってください
APPLY DECAL
HIER ABZIEHBILD
APPLIQUER DECALOMANIE
APPLIQUER DECALOMANIE
ASETA SIHTOKUVA
APPLIQUERA DECALEN
貼上水印紙

穴を埋めてください
FILL HOLE
SÖHLESSEN
BOUCHER LE TROU
FORD PIENO
TAYTÄ REIKÄ
FYLL HALET
把孔填平

接着剤が乾くまで2~3分待つてください
PLEASE WAIT FOR A FEW MINUTES UNTIL DRY
ENGJE MINUTEN WARTEN BIS DER KLEBSTOFF GETROCKNET IST
APFERTRE ALDIN MINUTTI PINOHE LA KOLLA EIÄ ACCUGAR
VEUILLEZ PATIENTER QUELQUES JUSQU'AU SECHAGE
VÄRTA INGRÄMINUTER TILLS TORR
OODA MÄÄRÄÄ MINUUTTI KÄÄNÄS KÄÄNÄT
稍候數分鐘 直至接著劑乾固

注意してください
BE CAREFUL
HIER VORSICHT
FAIRE ATTENTION
USARE ATTENZIONE
VAROASTI
FORIKTIGT
小心留意

穴を開けてください
OPEN HOLE
ÖFFNEN
FAIRE UN TROU
FORO APERTO
AVAA REIKÄ
OPPNA HALET
鑽孔

接着してください
CEMENT TOGETHER
ZUSAMMENKLEBEN
COLLER ENSEMBLE
INCOLLARE INSIEME
LIMMA YHTEEN
LIMMA (HOP)
用膠黏合

折り曲げてください
BEND
BITTE BIEGEN
PLIER S'IL VOUS PLAÎT
PIEGARE
TAITA
BOKKA
屈曲



どちらか選択してください
OPTIONAL
NACH BELIEBEN
FACULTATIF
FACOLTATIVO
VALINNANVARAINEN
VALBAR
可以選擇採用

瞬間接着剤(金属用)
INSTANT GLUE FOR METAL
METALLKLEBER
COLLA A METAL INSTANTANEE
COLLA INSTANTANEA PER METALU
PIKALIMAA METALLIOSIA VARTEN
SNÄBLIM FOR METALLDELAR
金屬用速乾膠

H1 GSI CREOS CORP. AQUEOUS HOBBY COLOR 1 GSI CREOS CORP. MR. COLOR MODEL MASTER COLOR

H1162	つや消しホワイト	1768	FLAT WHITE	MATTWEISS	BLANC MAT	BLANCO OPACO	啞白色
H1233	つや消しブラック	1749	FLAT BLACK	MATTSCHWARZ	NOIR MAT	NERO OPACO	啞黑色
H1828	黒鉄色	1415	STEEL	STAHL	ACIER	ACCIAIO	黒銀色
H3743	ウッドブラウン	1735	WOOD BROWN	HOLZBRAUN	BRUN BOIS	MARRONE LEGNO	木棕色
H4741	レッドブラウン	1533	RED BROWN	ROTBRAUN	MARRON ROUGE	MARRONE ROSSICCIO	紅褐, 啡紅色
H7121	ミドルストーン	2137	MIDDLE STONE	STEINGRAU, MITTEL	PIERRE MOYEN	NOCCIOLA MEDIO	中石色
H7661	焼鉄色	1406	BURNED IRON	GEBR, EISEN	FER BRULÉ	FERRO BRUCIATO	燒鐵色
H8054	カーキグリーン	1710	KHAKI GREEN	KHAKIGRÜN	VERT KHAKI	VERDE KAKI	砵礮綠色
H403	ダークイエロー	2095	DARK YELLOW	DUNKEL GELB	JAUNÉ FONCÉ	GIALLO SCURO	暗黃色

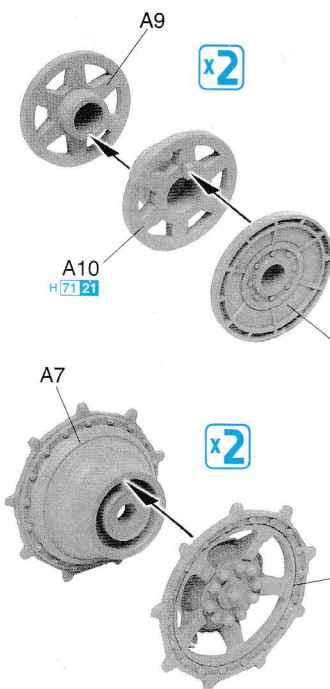
1



2

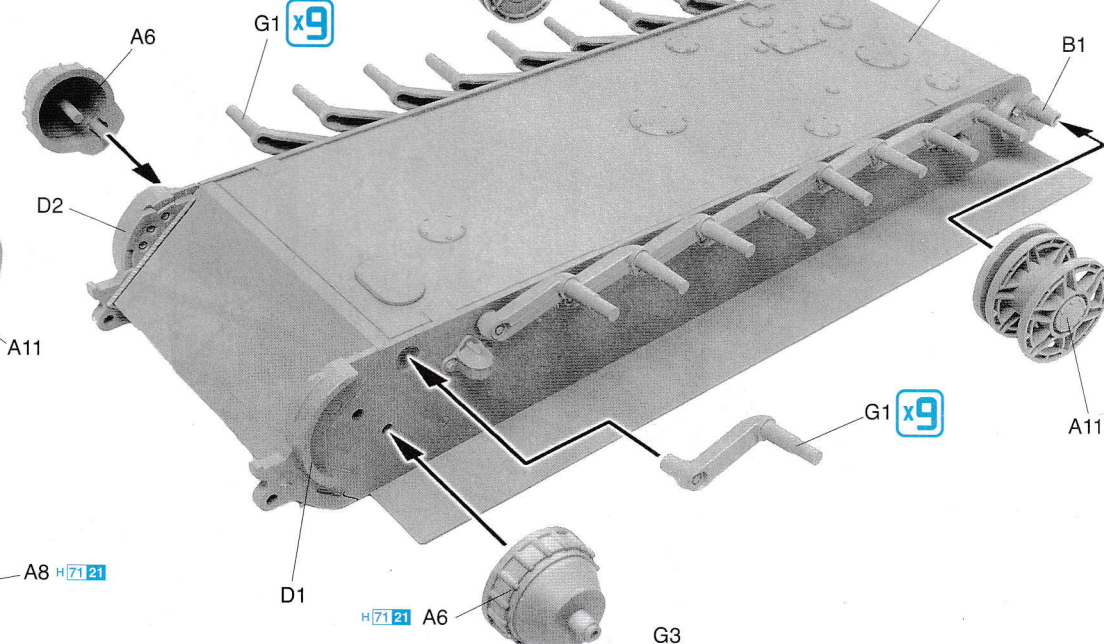

3

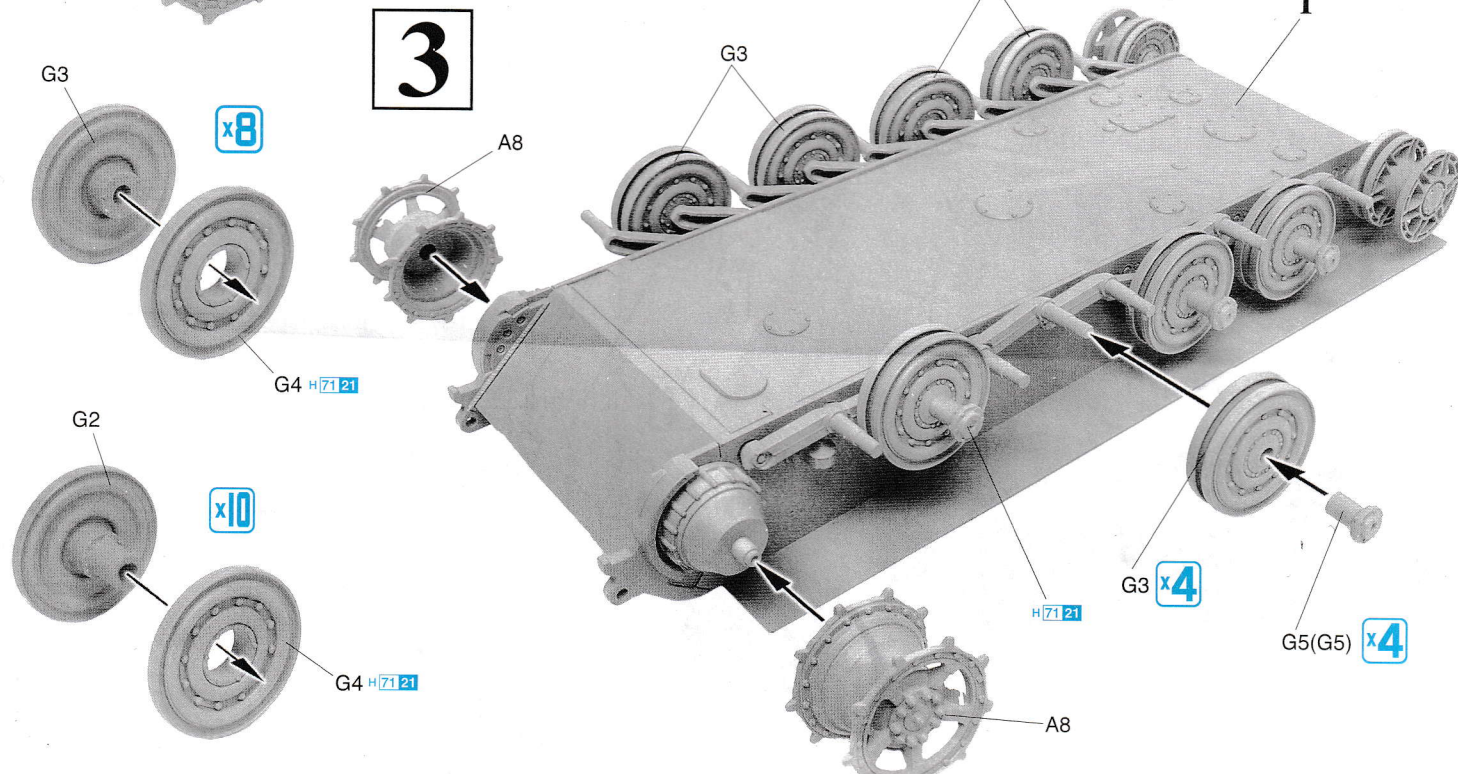

4

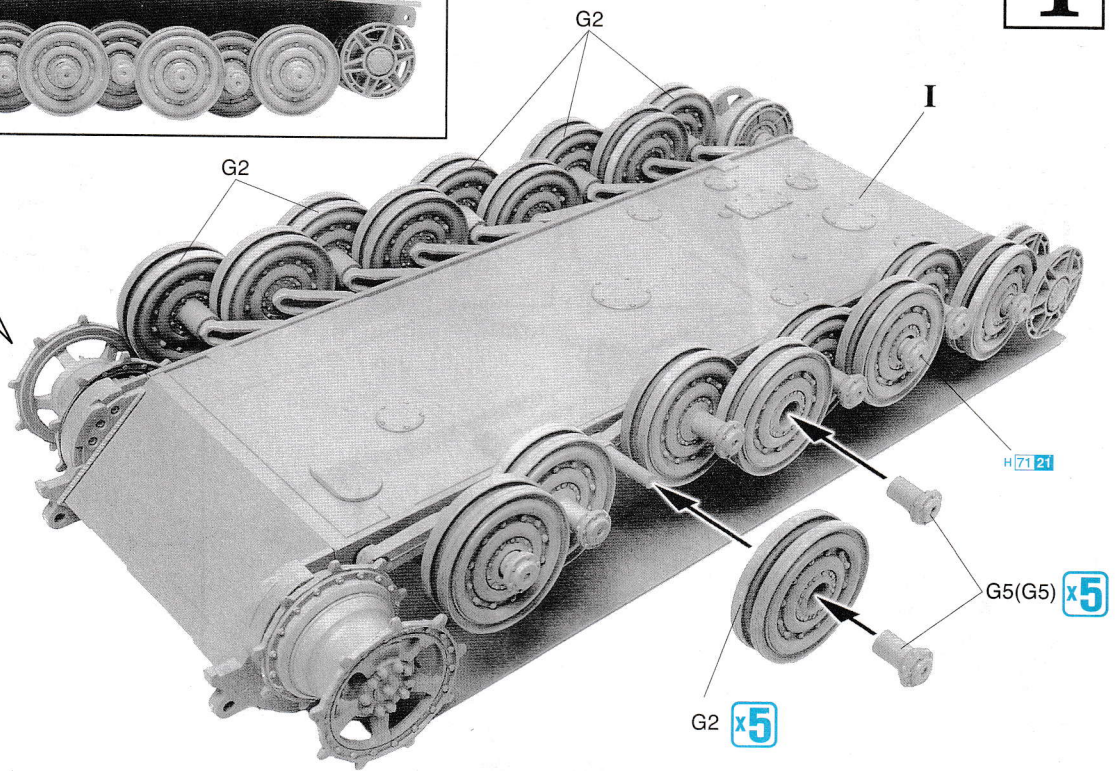
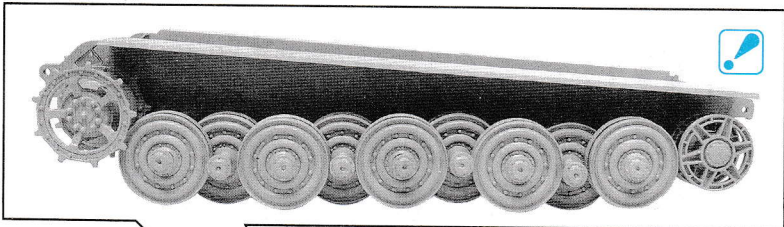

5

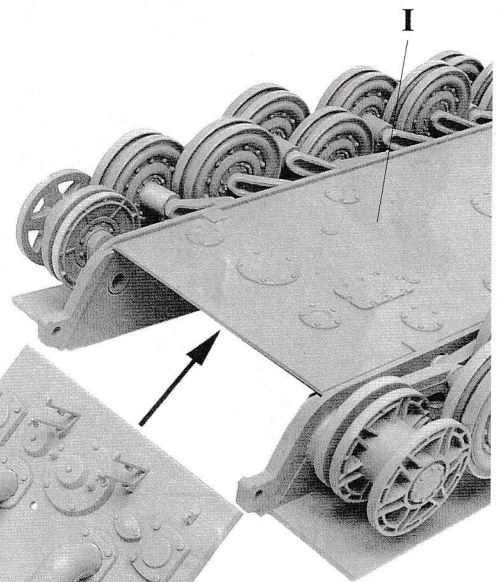
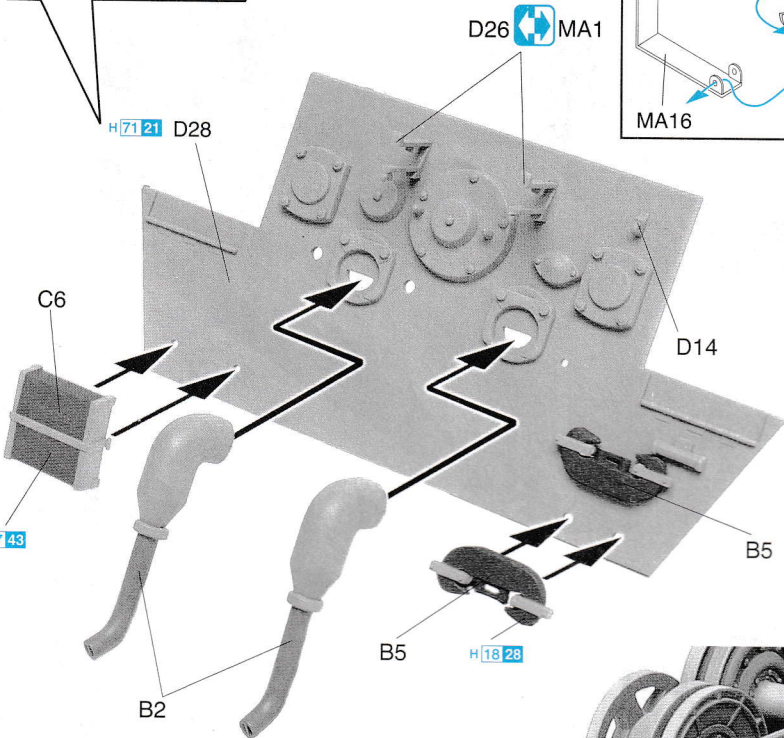
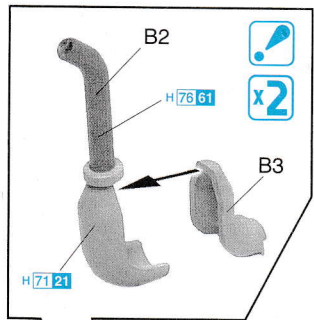

6

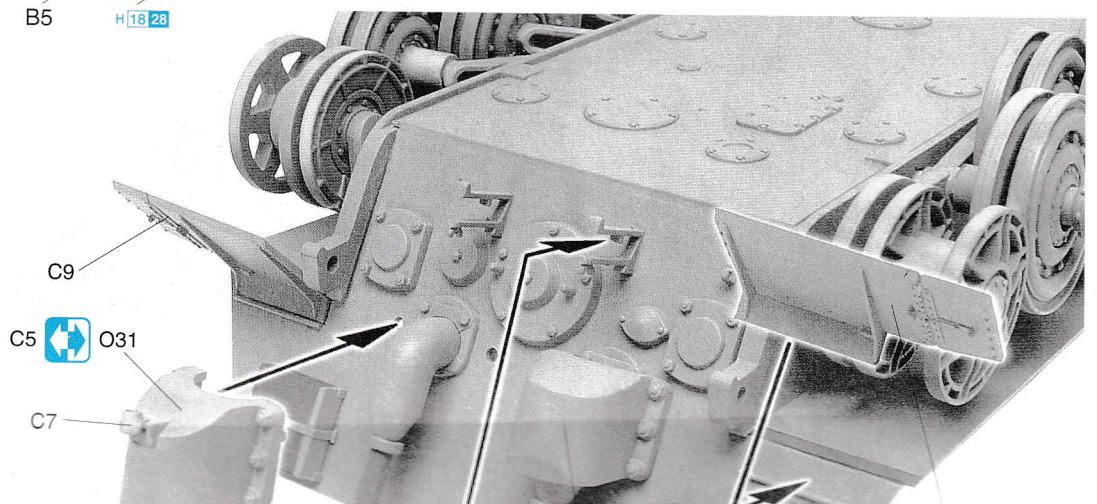

5

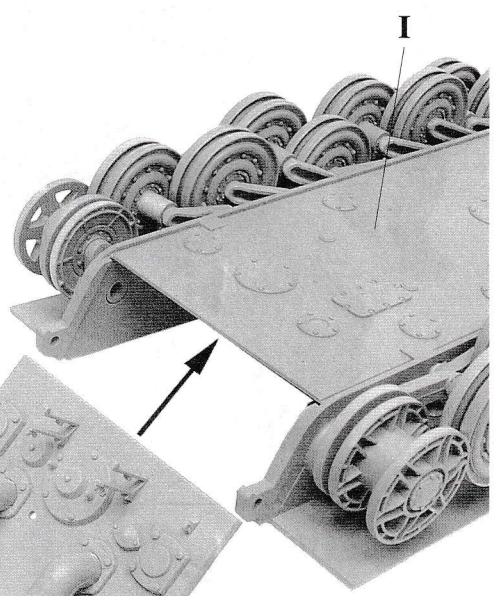
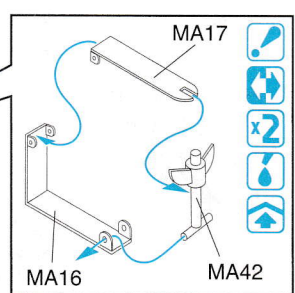
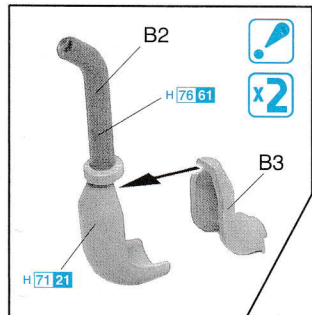
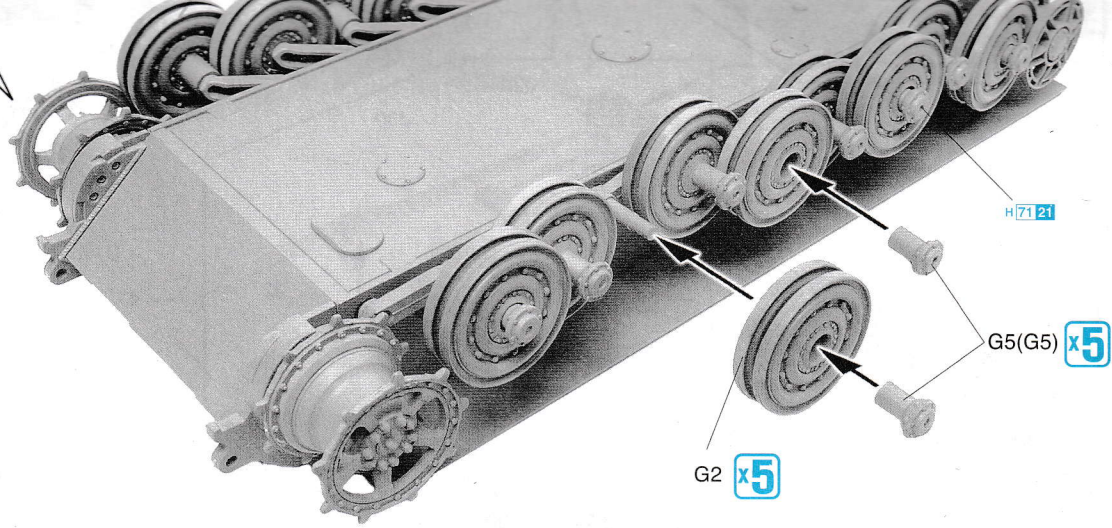

6

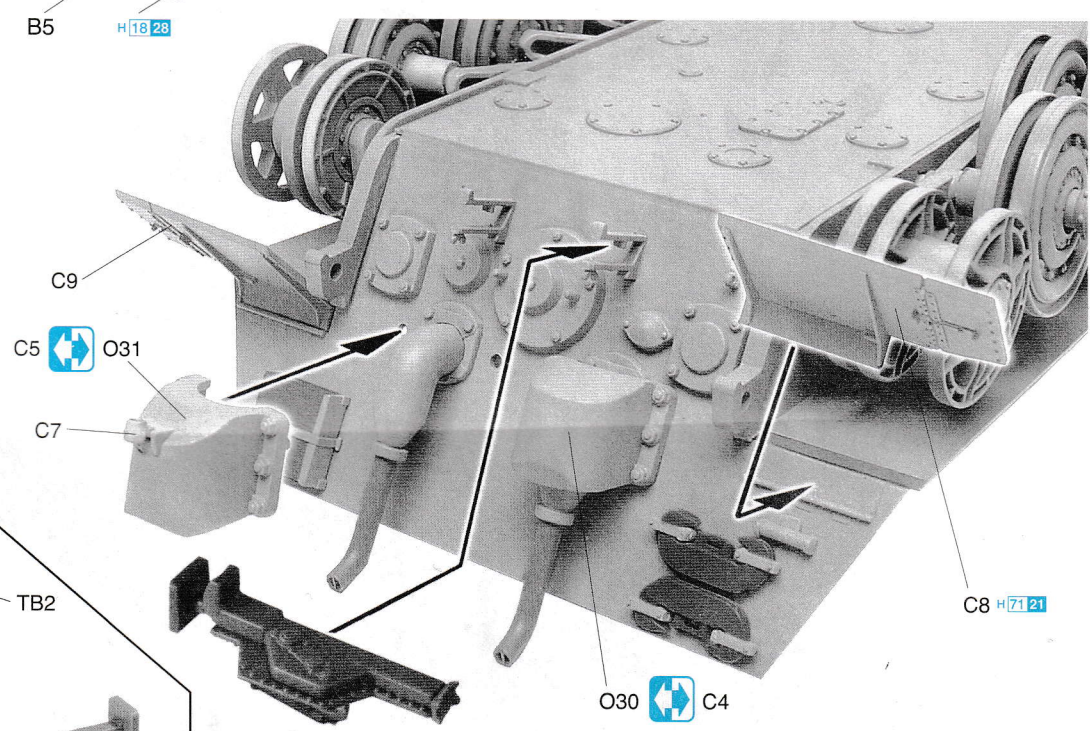
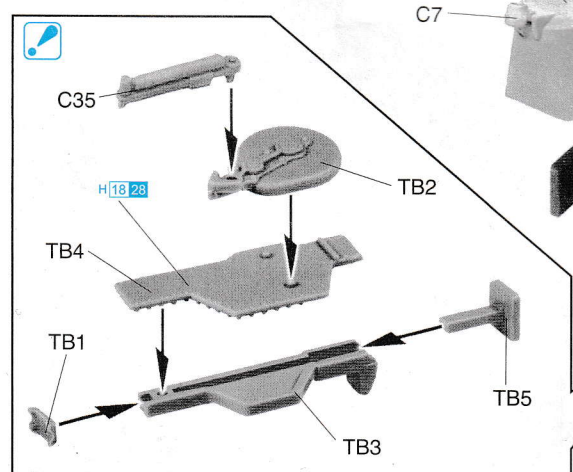
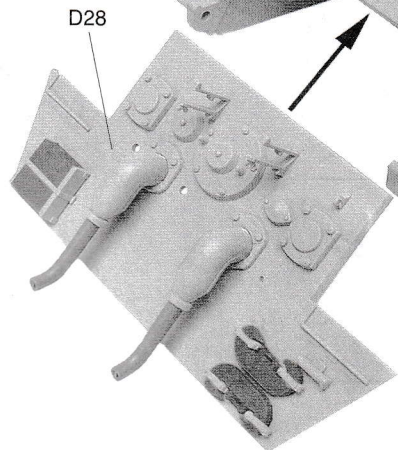
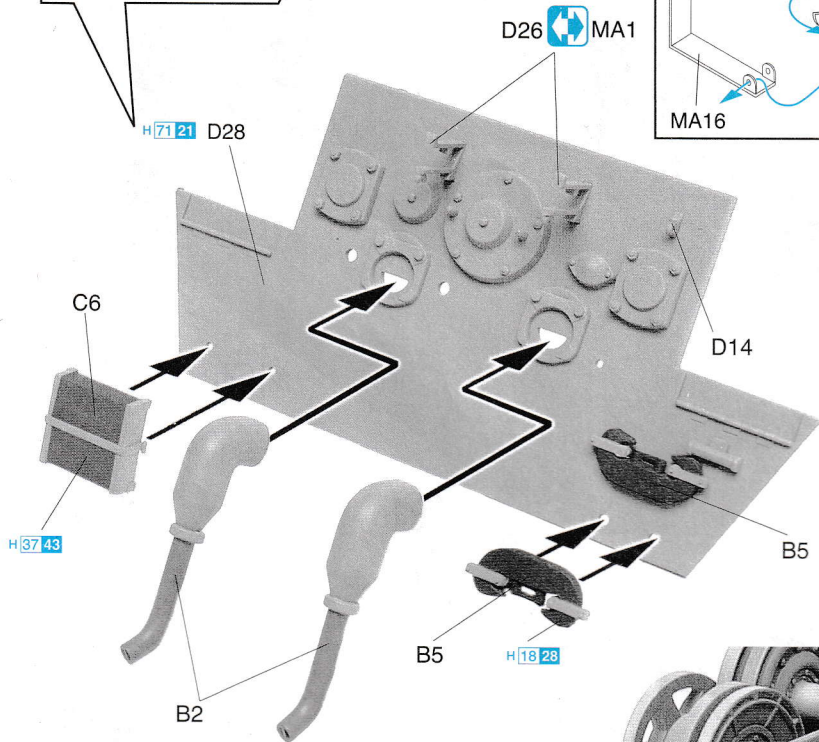

7

8

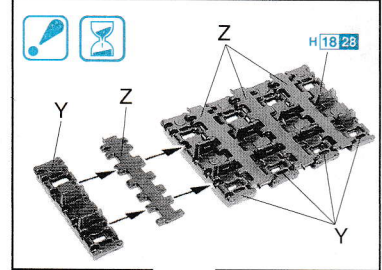
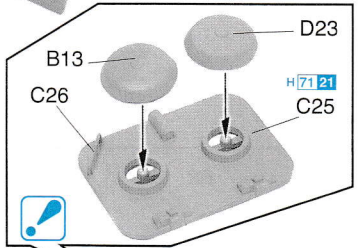
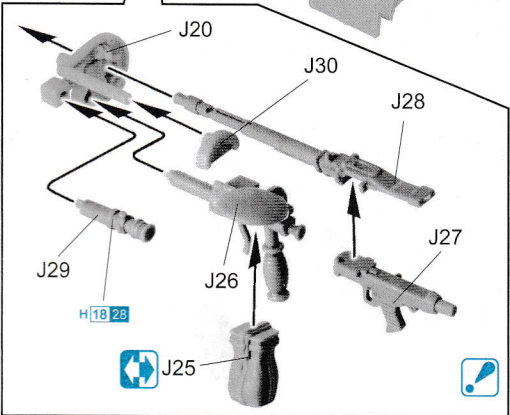
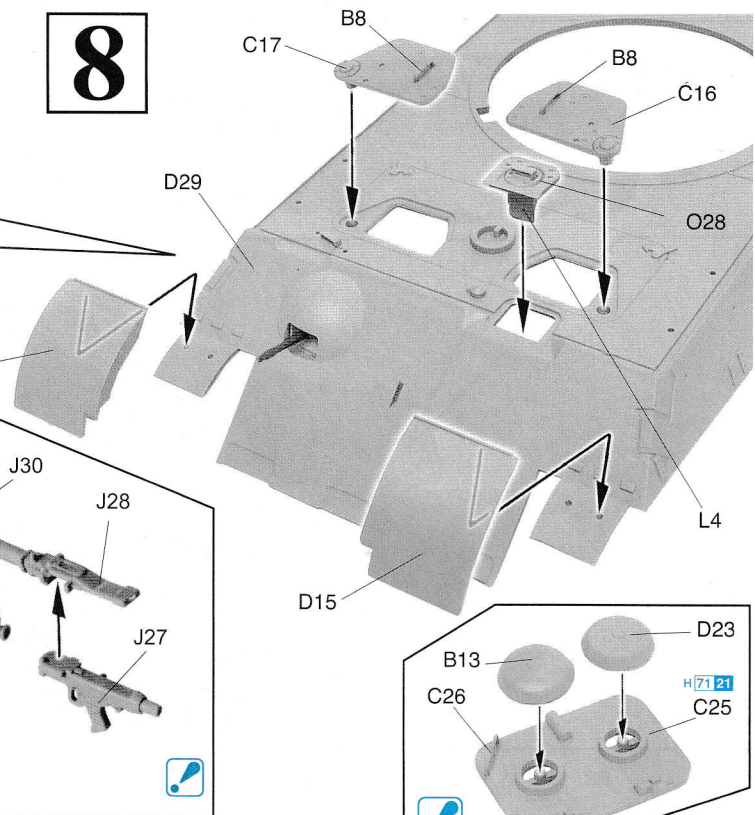
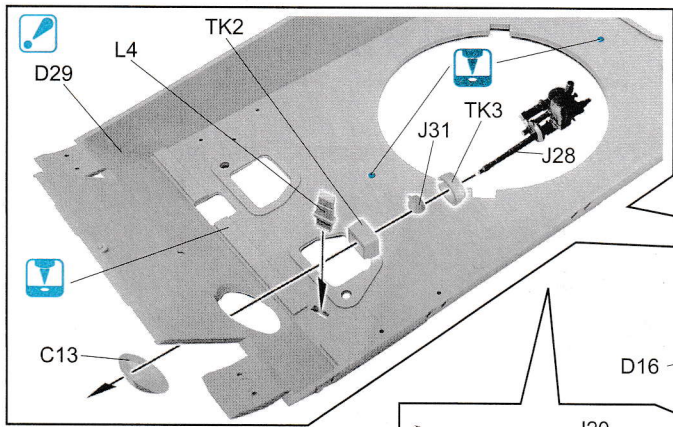

9

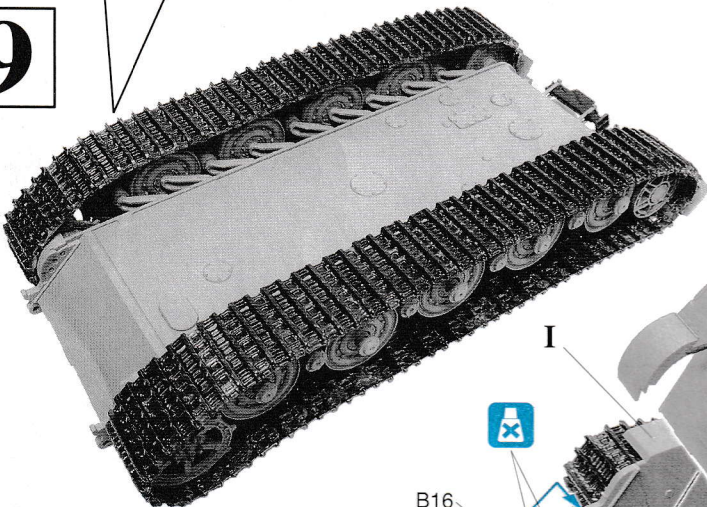

10

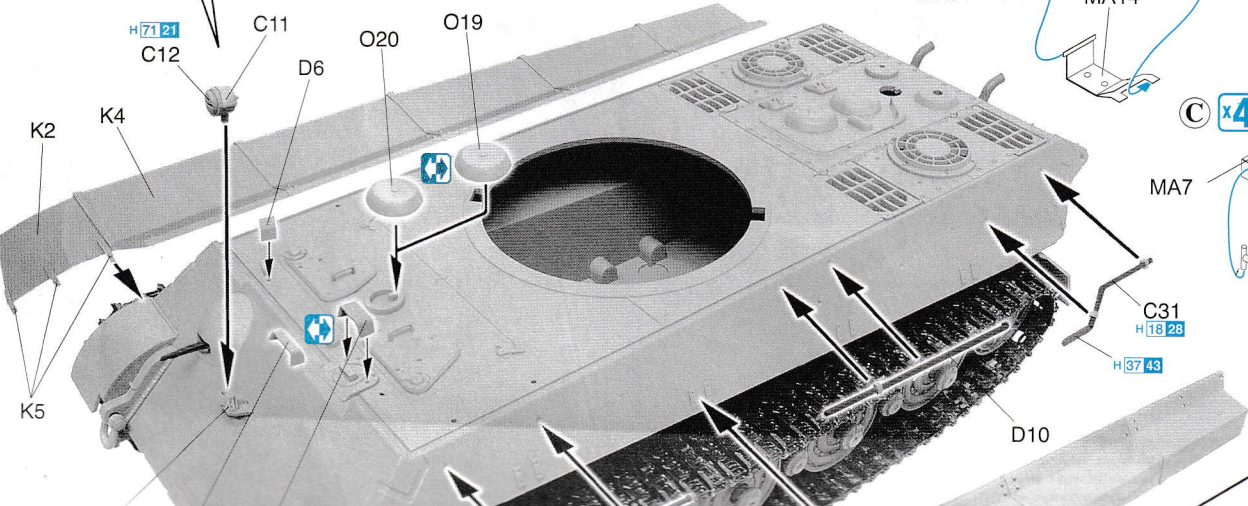
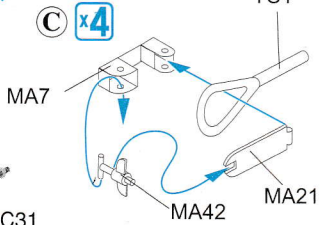
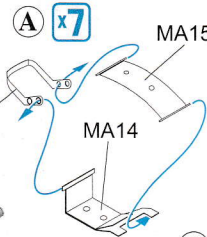
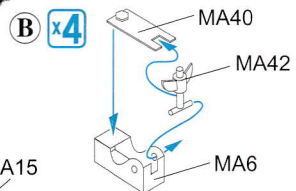
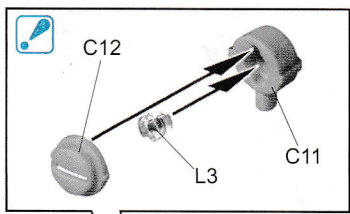
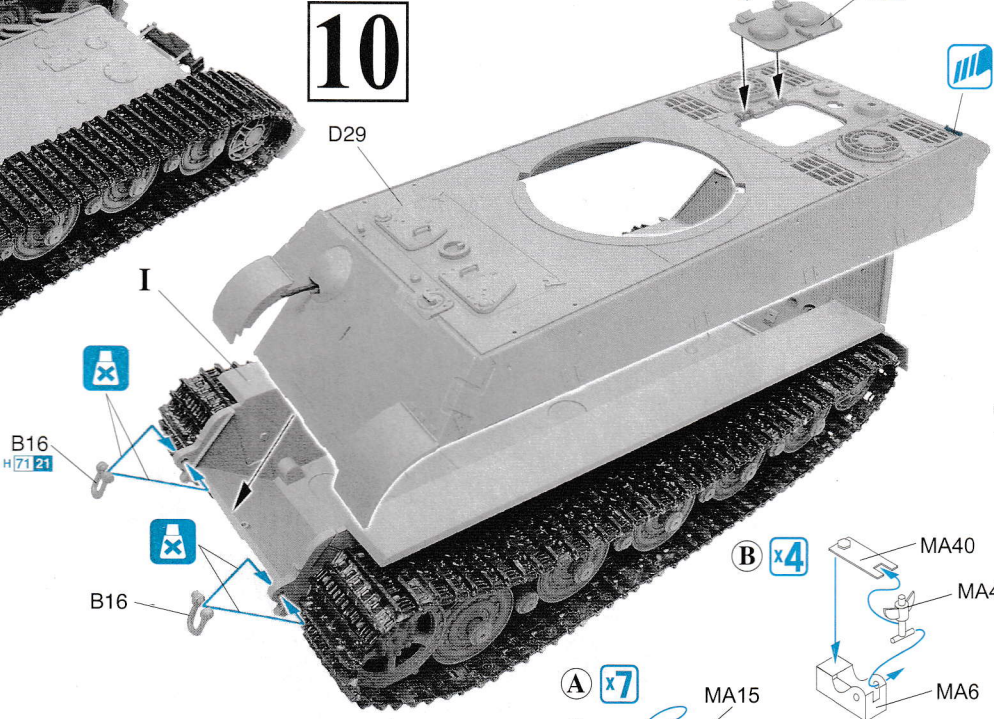

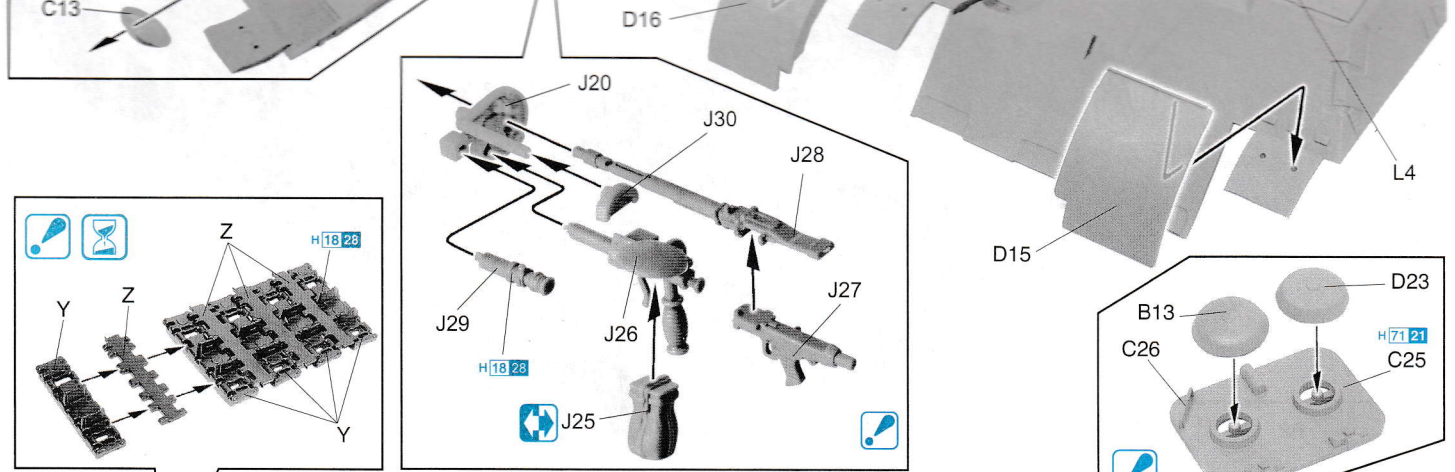

9

10

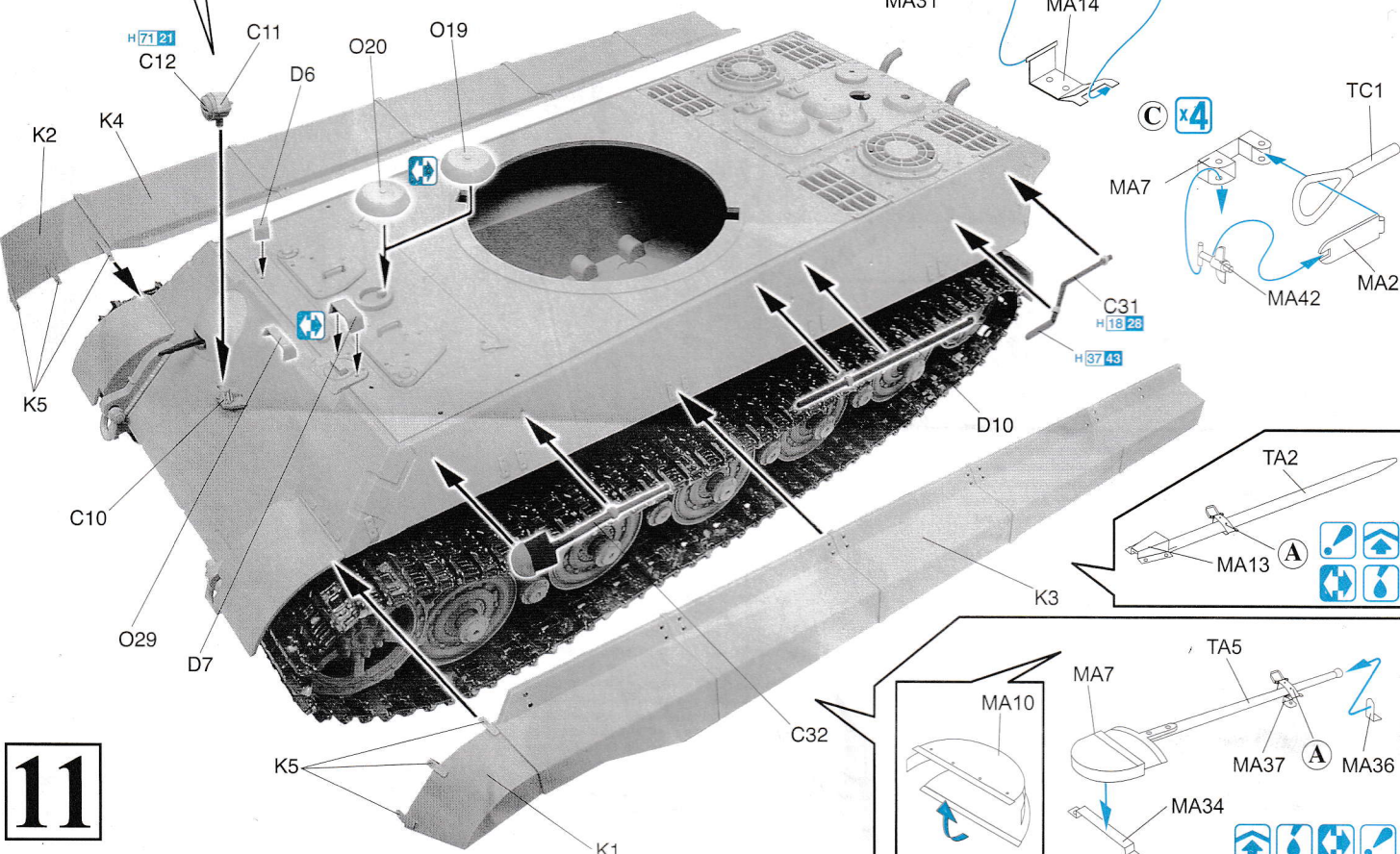
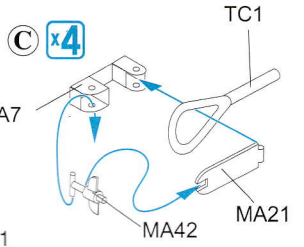
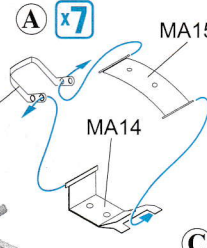
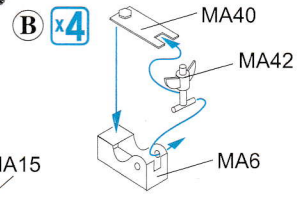
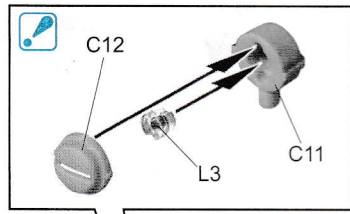
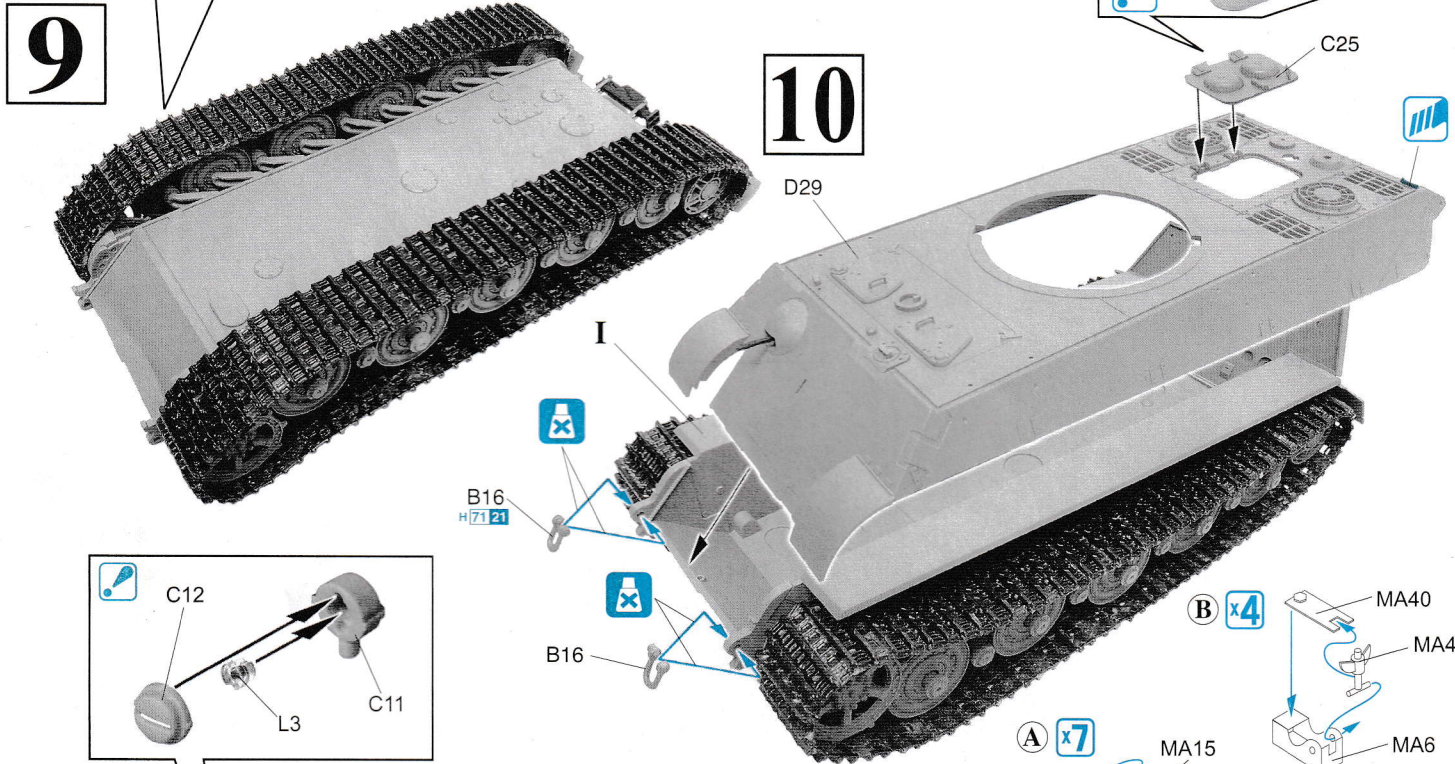

11

12

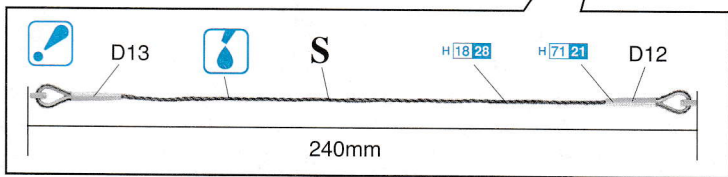
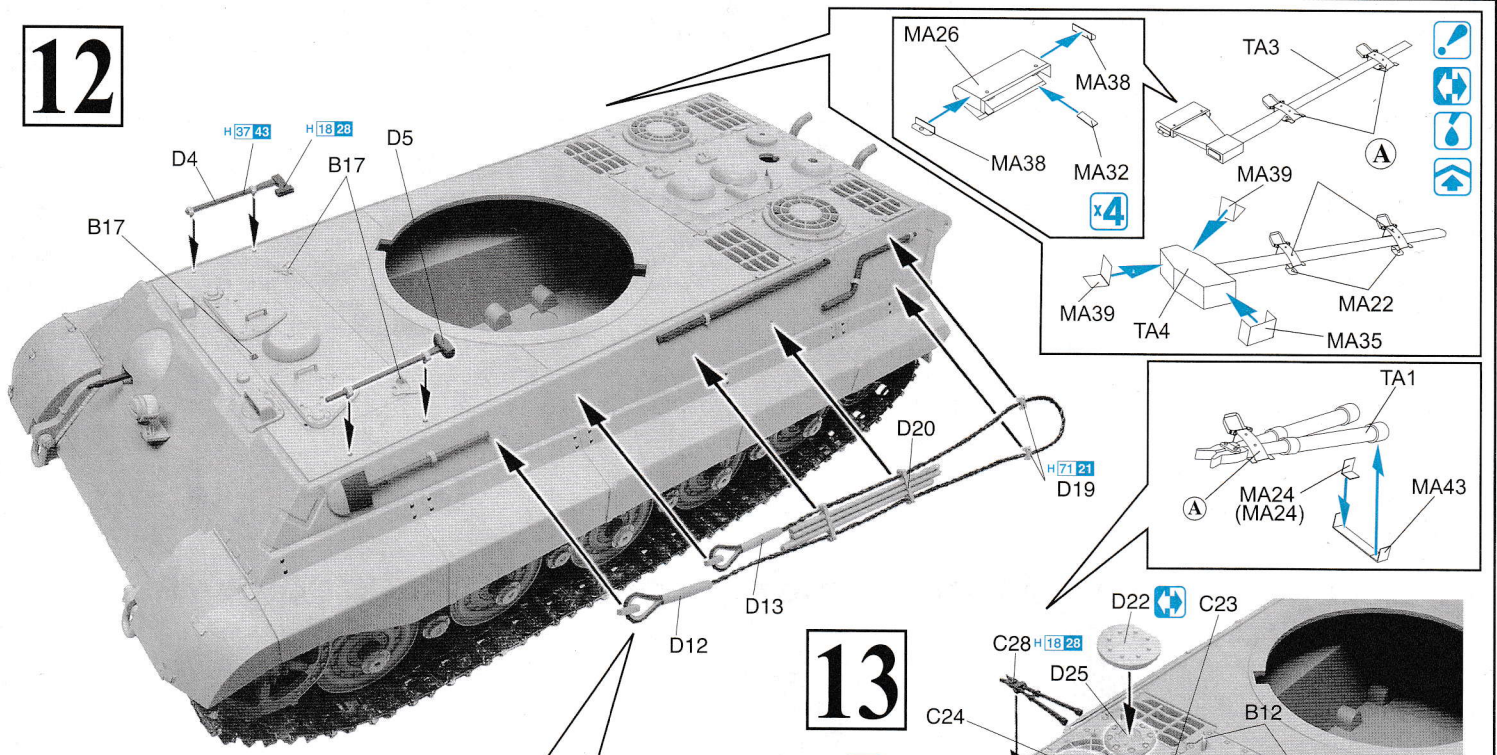

13

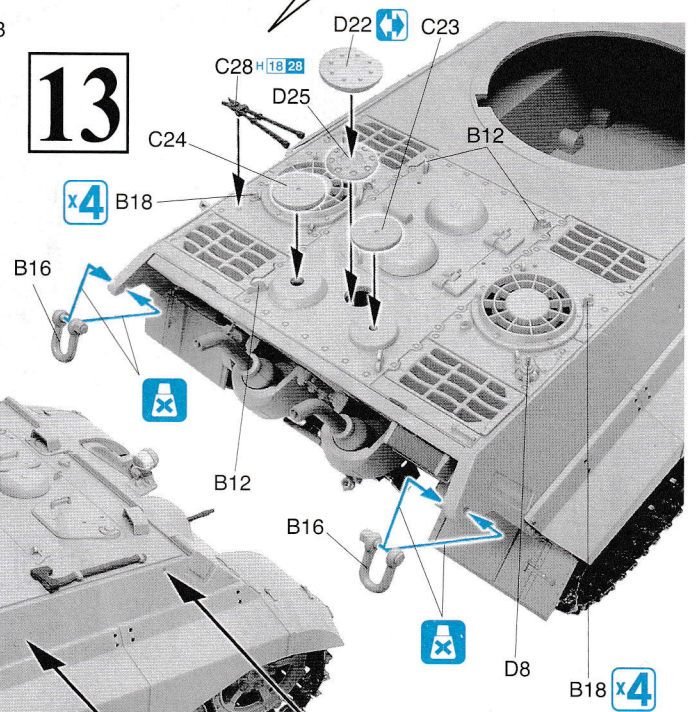

14

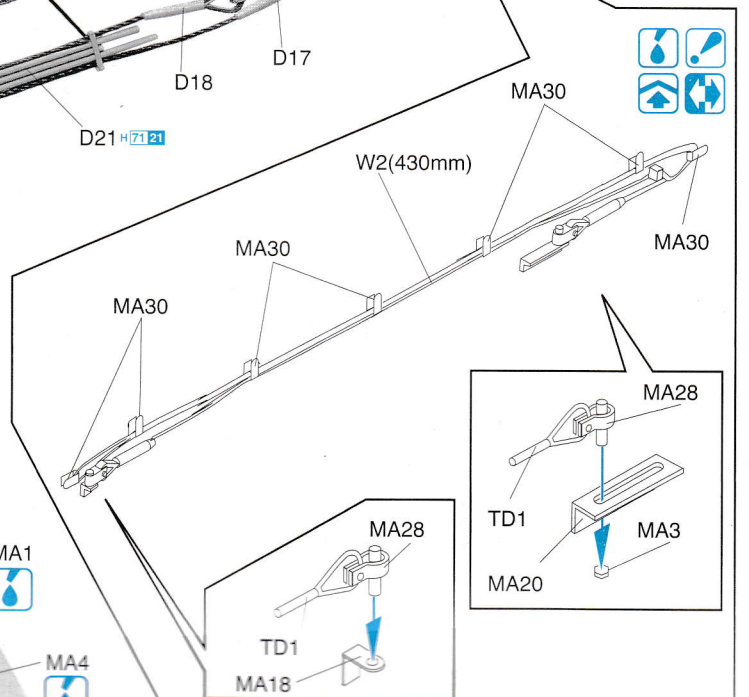
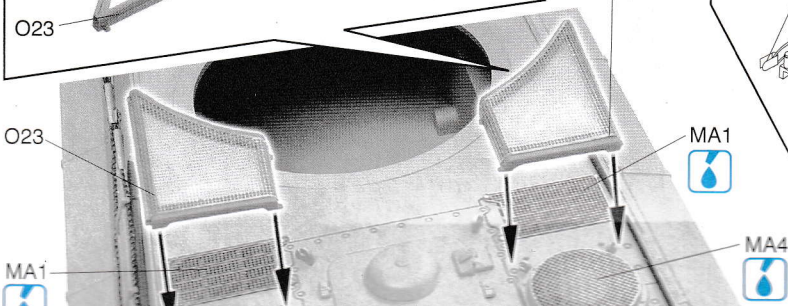
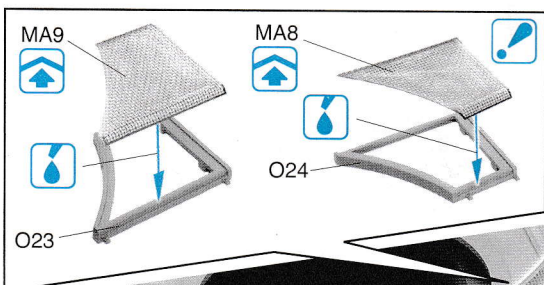
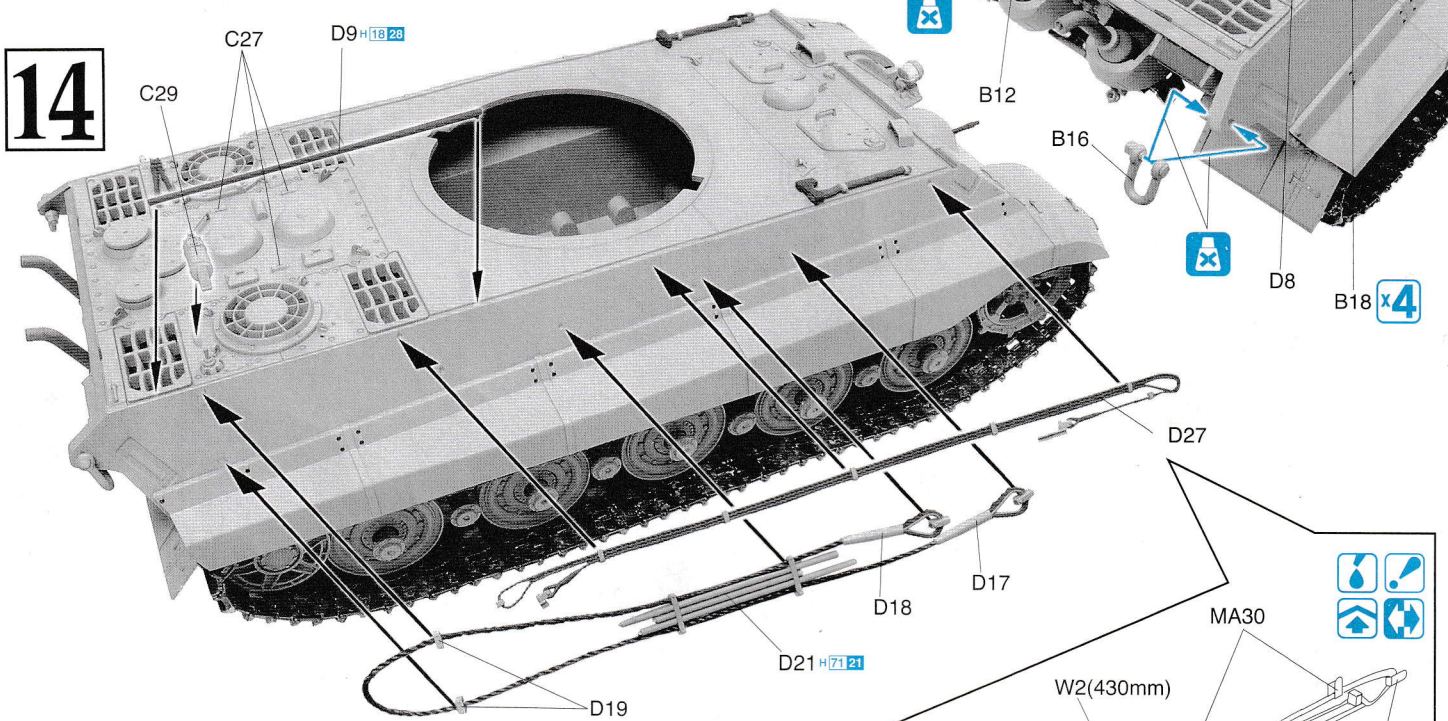

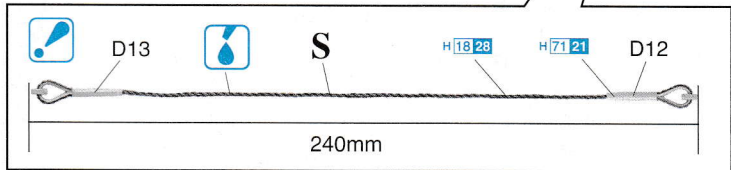
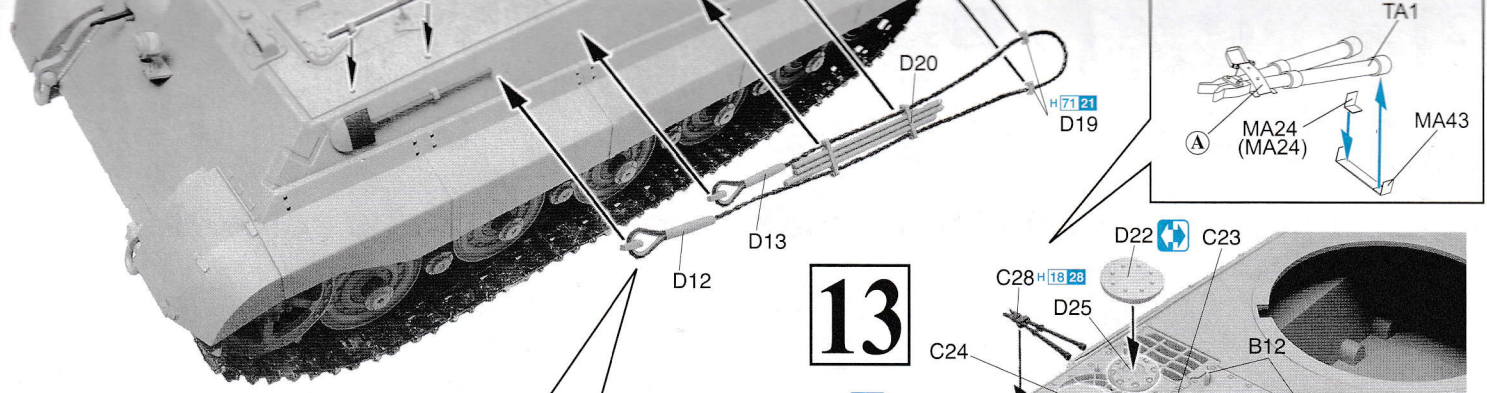

13

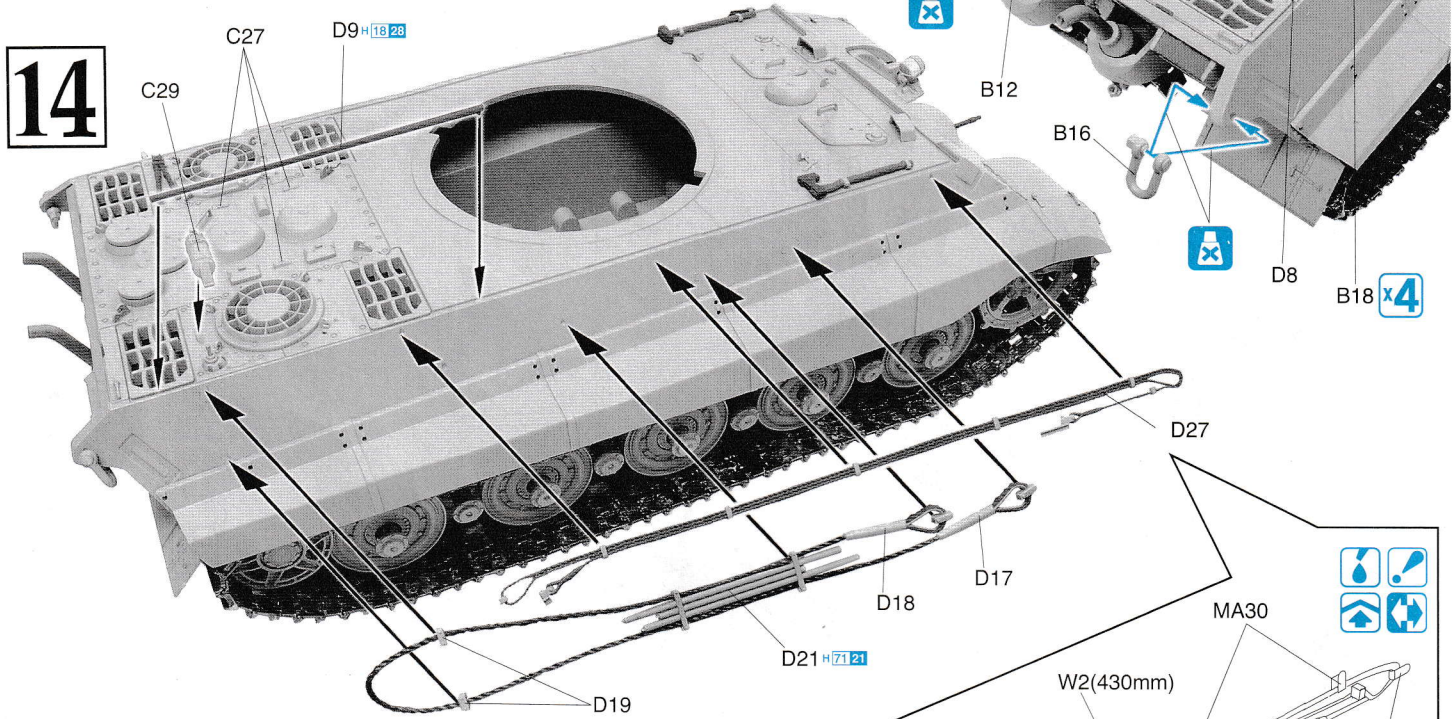

14

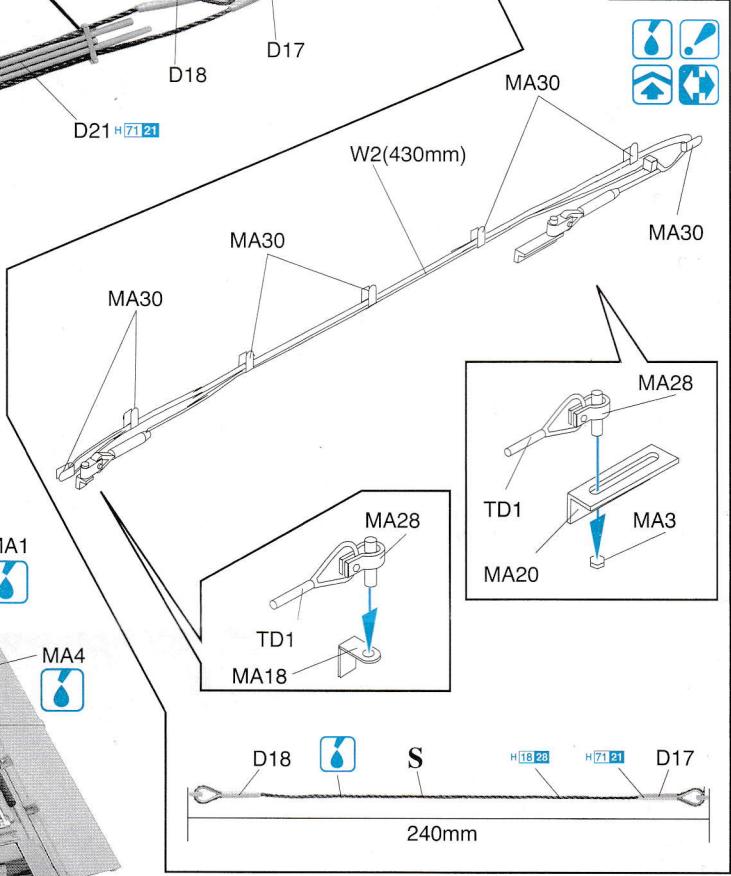
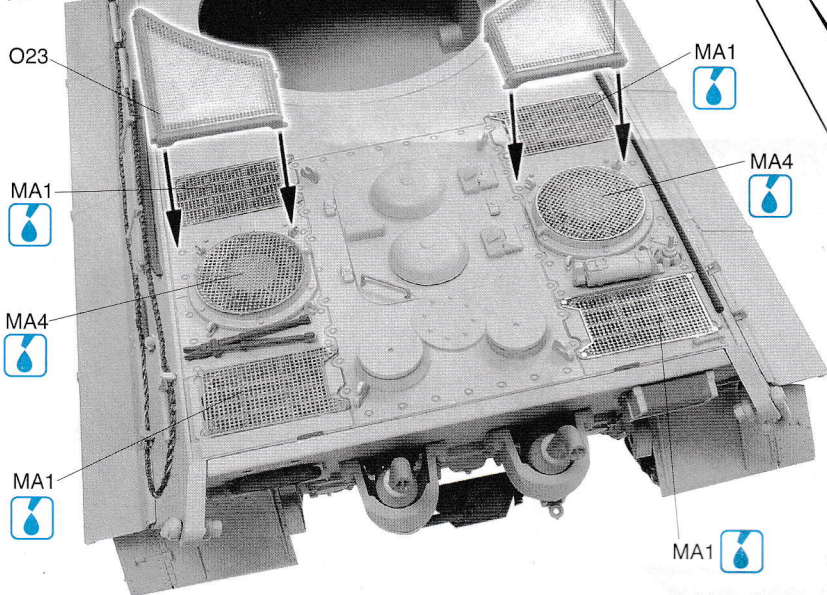
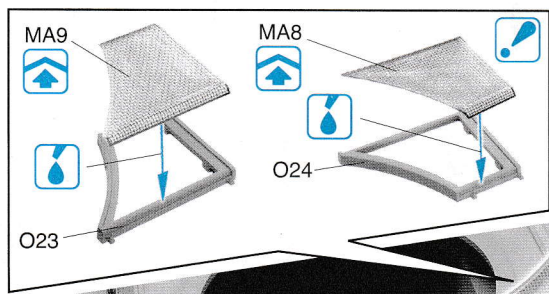

15

16

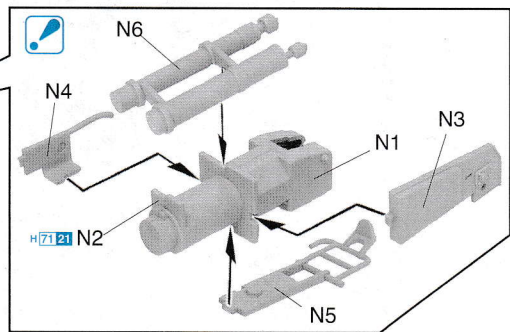
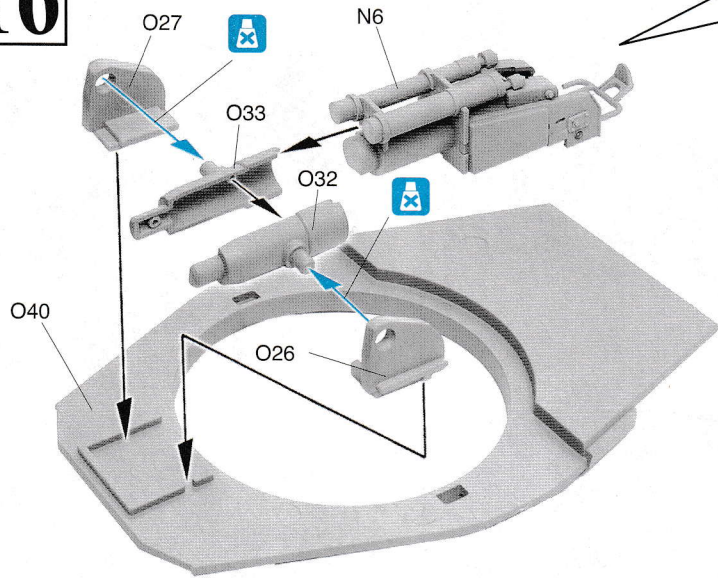

17

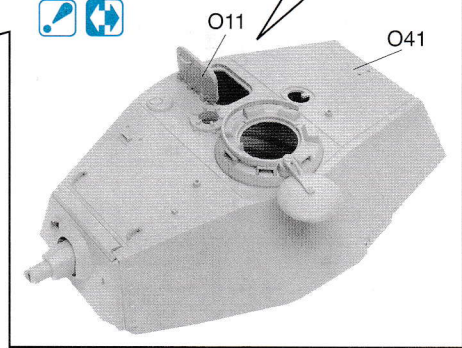
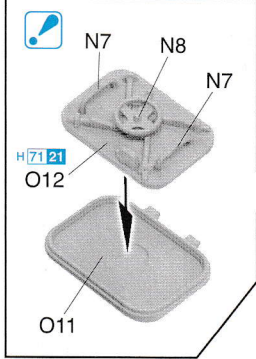
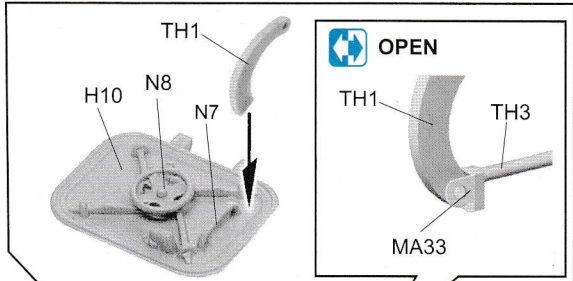
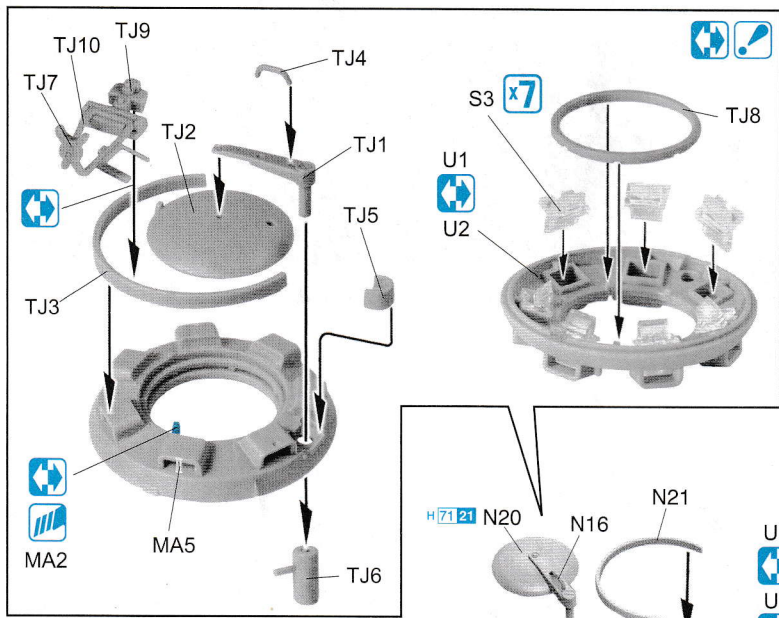
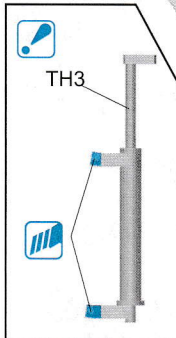
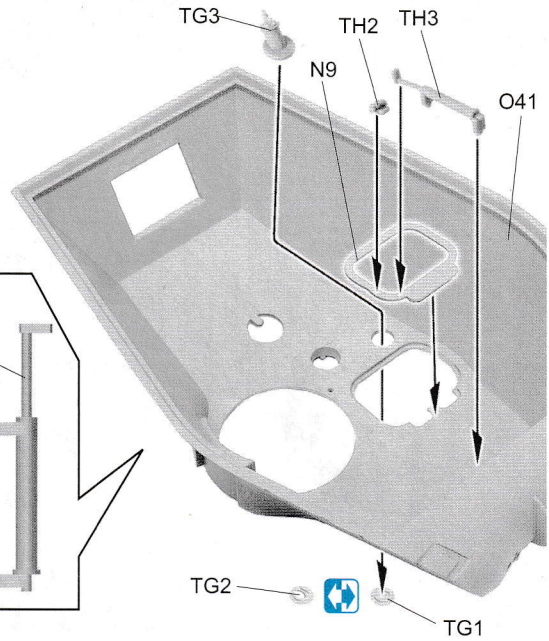

18

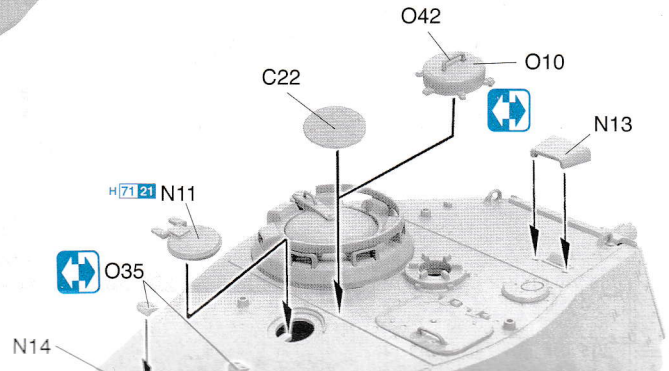
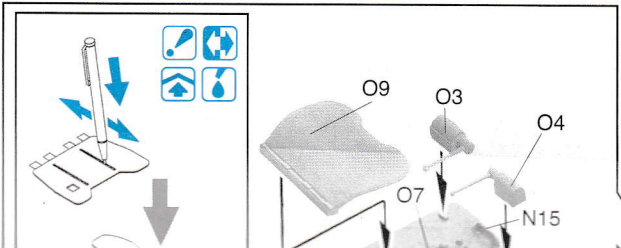
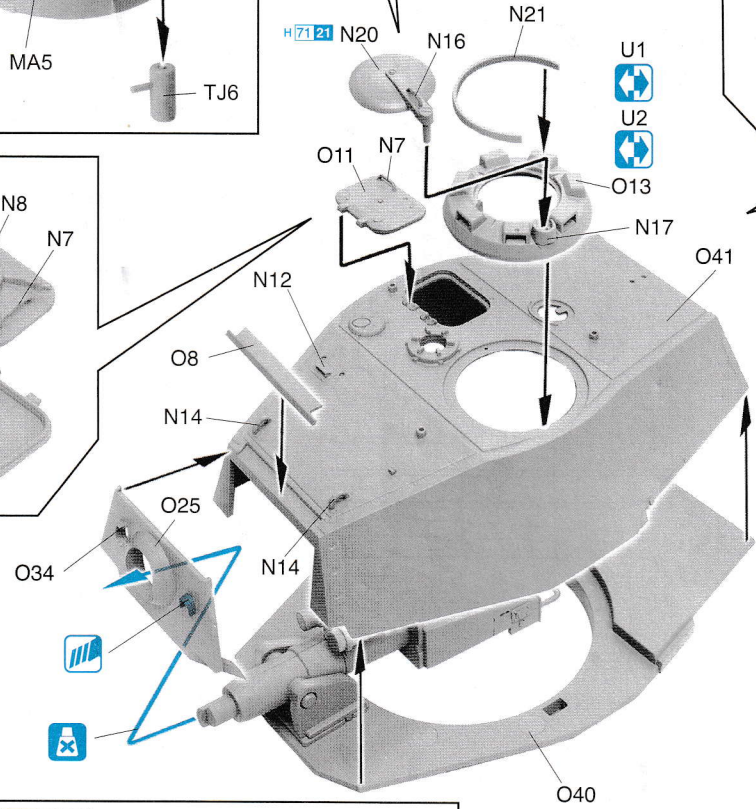

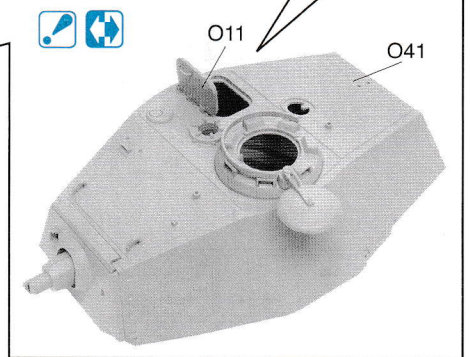
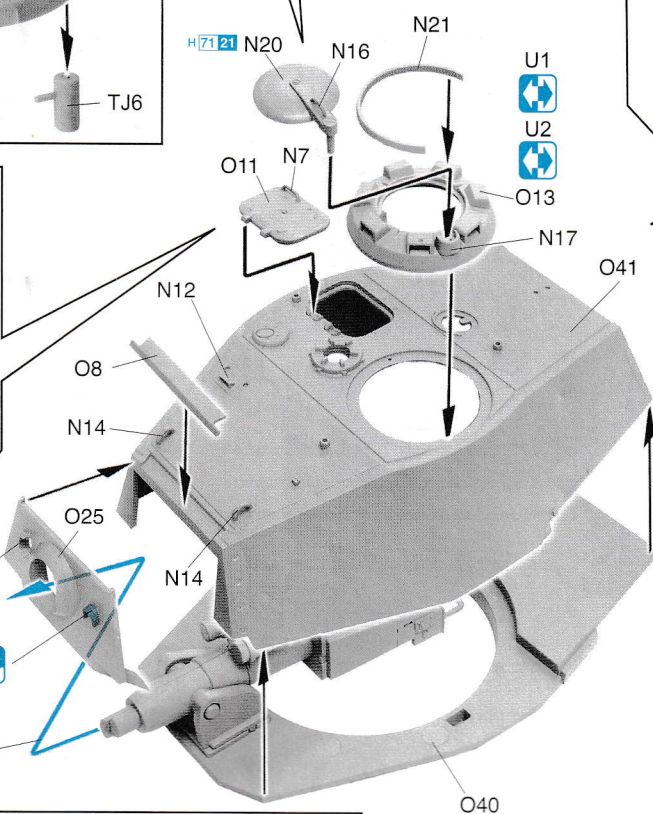
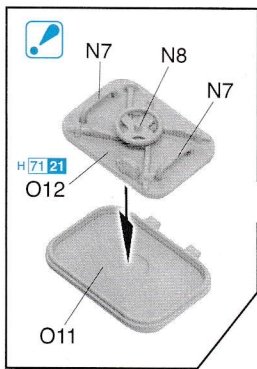
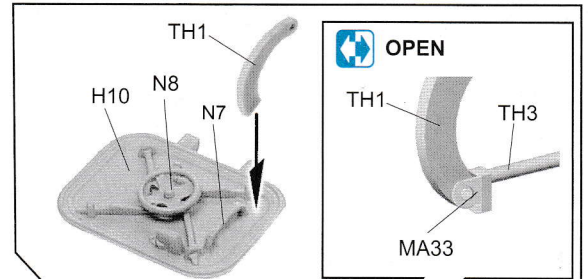
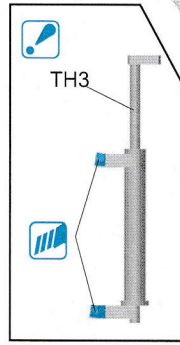
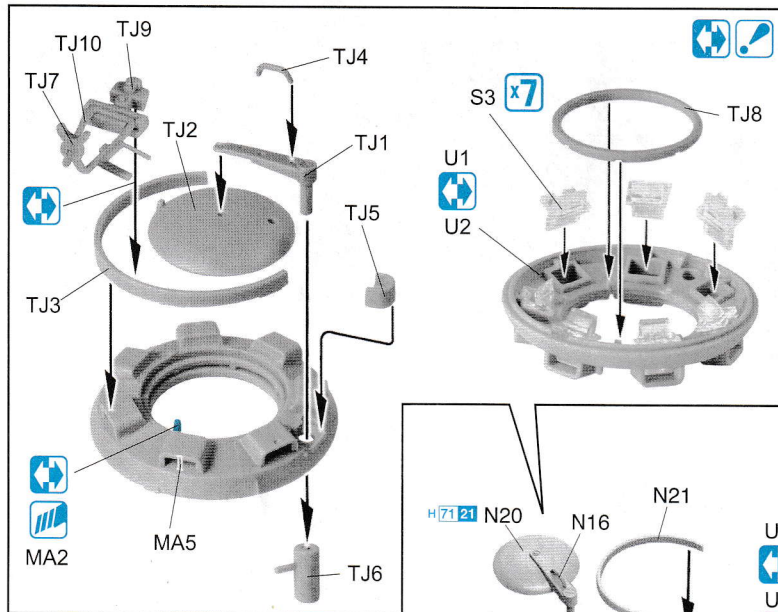
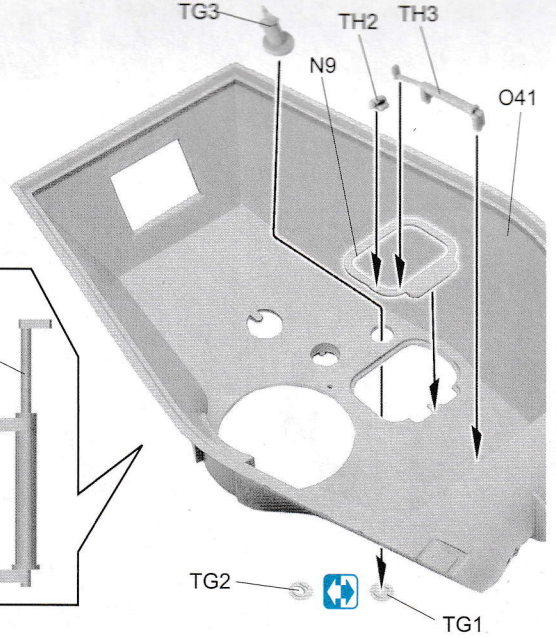
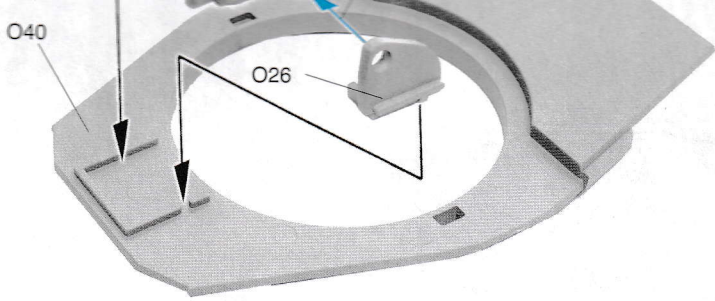

18

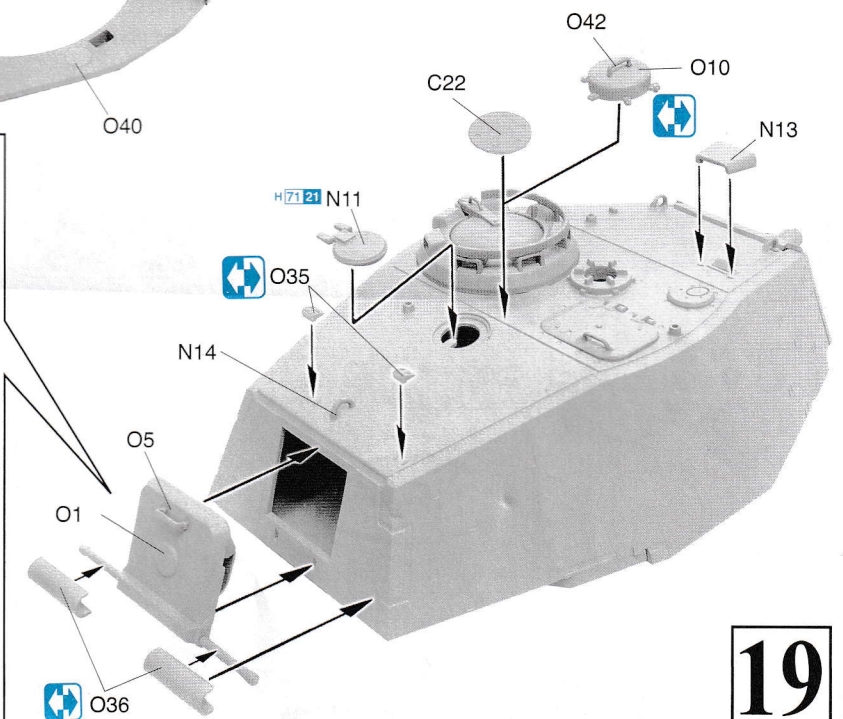
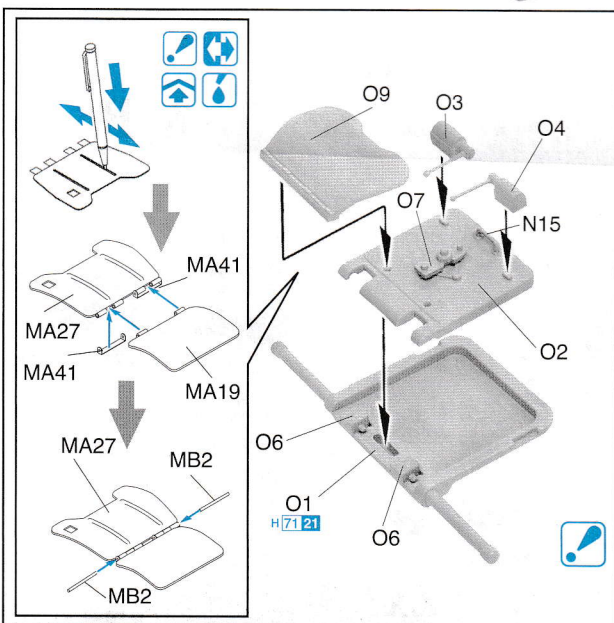

19

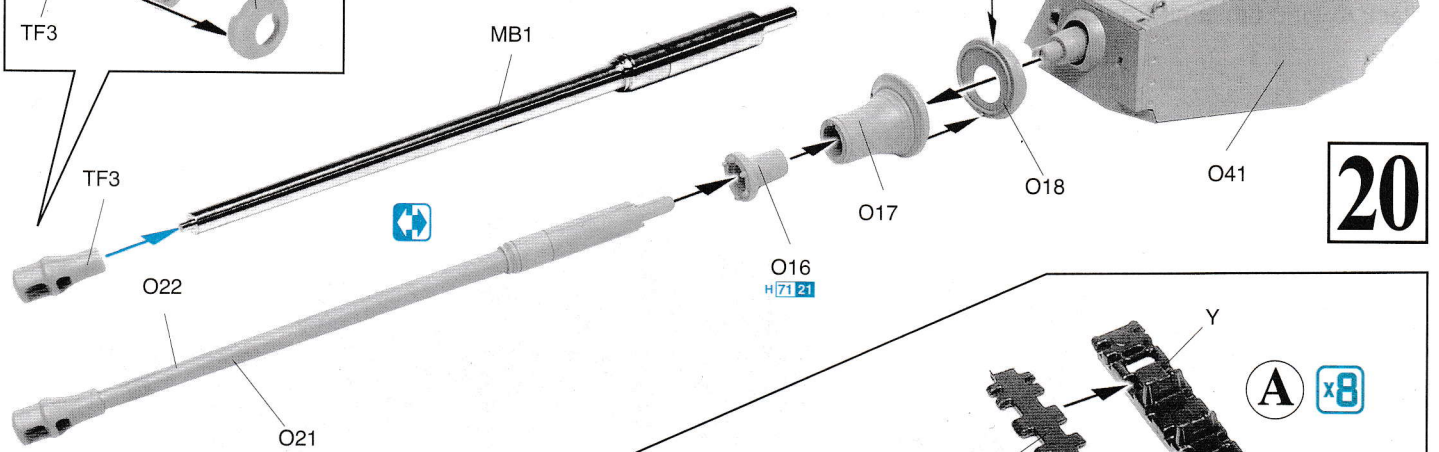
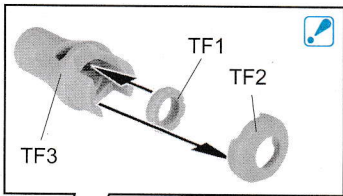

20

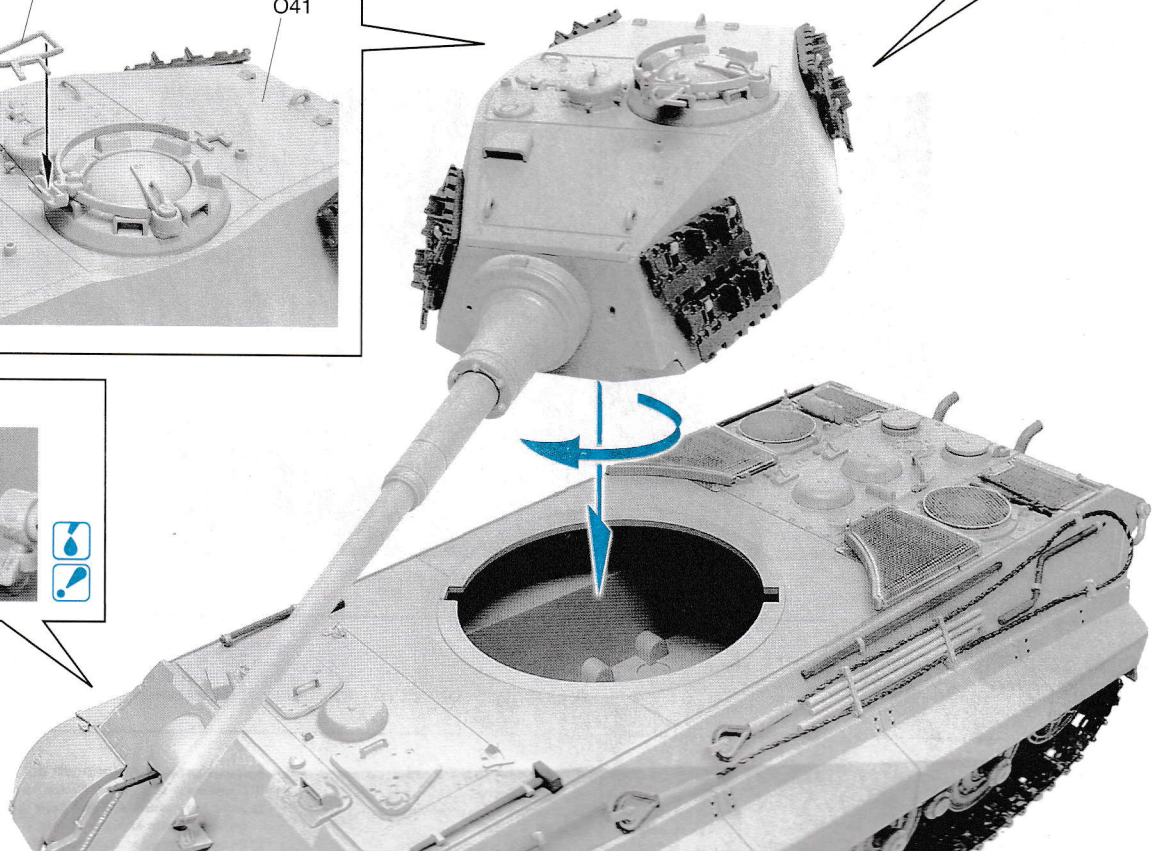
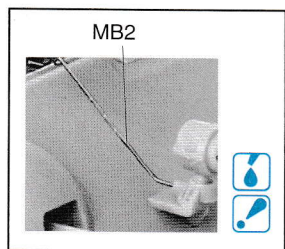
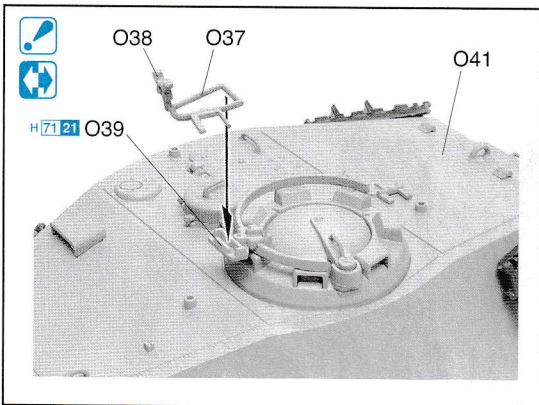
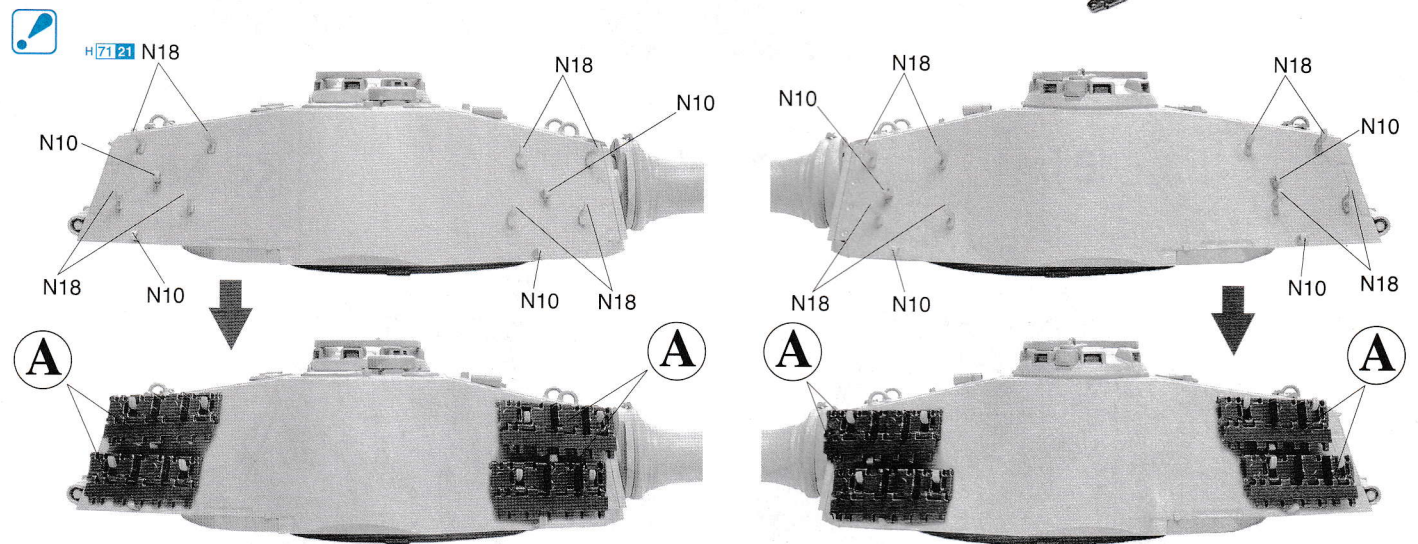
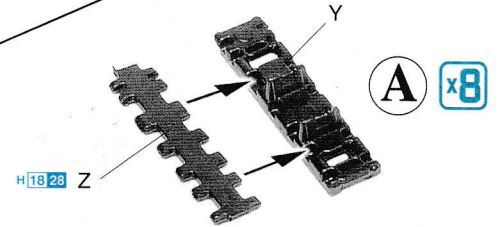

Painting & Markings

マーキング及び塗装図 Markierungen und Bemalung Decoration et Peinture Marchio & Pittura 標貼及着色指示

"Black Knight" 8th Tank Company, Eastern Front 1945

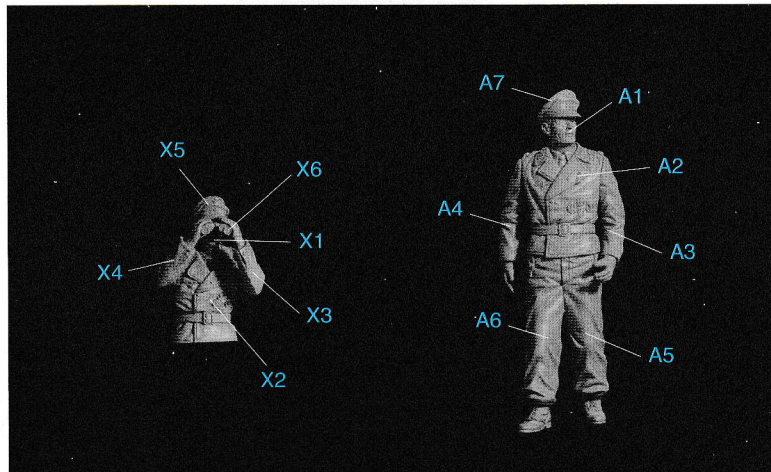
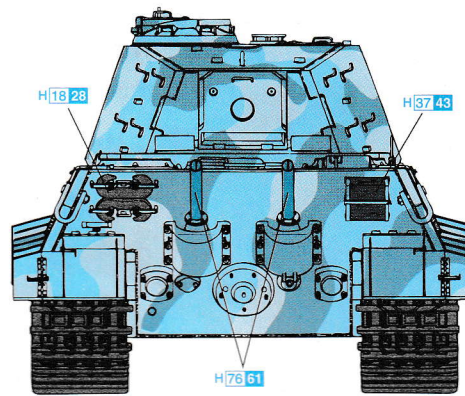
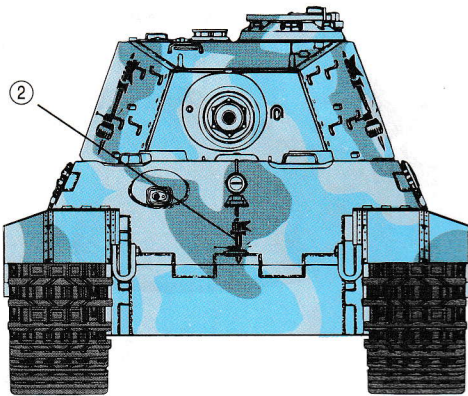
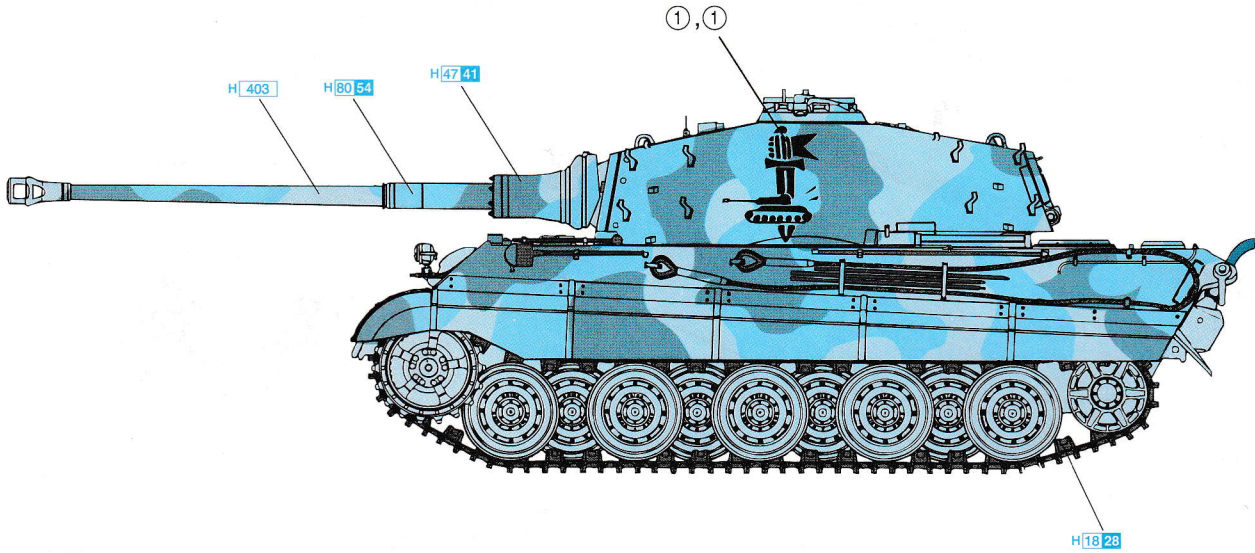

Dragon Europe: c/o Hobby Pro Marketing Ges. m.b.H.
Am Leonhardbach 7, A-8010 GRAZ, AUSTRIA

A Quality Product of



Copyright © 2012
6662-01

■ デカールの貼り方

- ① あらかじめデカールを貼る場所の汚れを拭き取ってください。
- ② 貼りたいデカールを切り取り、1枚ずつ水、またはぬるま湯に台紙を下に20秒ほど浸します。

■ Correct Method for Applying Decals

- ① Clean the model surface with a wet cloth.
- ② Cut out each decal design from the decal sheet, and dip it in warm water for 20 seconds.
- ③ Use a fingertip to check if the decal is loose from the

■ Das Korrekte Aufbringen der Abziehbilder

- ① Oberfläche des Modells mit feuchtem Tuch reinigen.
- ② Jedes Motiv einzeln aus dem Bogen herausschneiden und 20 Sekunden in warmes Wasser tauchen.
- ③ Mit dem Finger prüfen, ob sich das Motiv vom Trägerpapier löst.