

**MONOGRAM**<sup>®</sup>

# Heinkel He 111H "Blitz" Bomber

1/48 SCALE 1/48 ESCELLE ESCALA 1/48 MASSTAB 1:48

KIT 5509

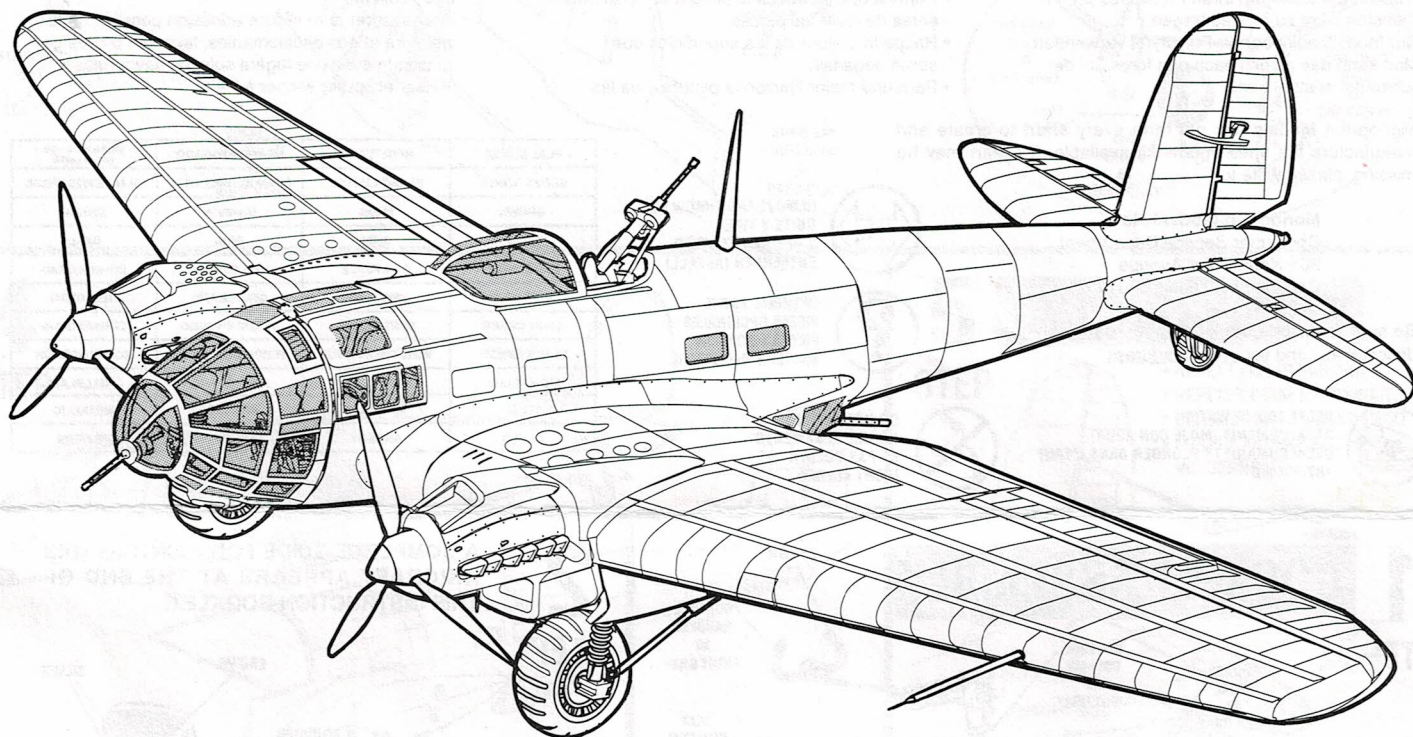

The Heinkel He III was the only twin-engined plane used by the Luftwaffe as a bomber that soldiered on, basically unchanged, from the first day of World War Two through to VE Day. The versatile, inspired design was aircraft engineer Ernst Heinkel's response to the RLM requirement for a high speed medium bomber, upon which the German high command based much of its "Blitzkrieg", or lightning-war strategy. Their theory was that large numbers of fast, smaller bombers would create a far more effective attack than fewer, slow, heavier bombers. In the context of history, their plan worked. The Heinkels flew with devastating results in the Spanish Civil War and Poland, where it was actually faster than many opposing fighters. However, during the Battle of Britain, when faced with determined single engined-fighters like the Spitfire and Hurricane, the lightly-armed and initially

unescorted Heinkel formations suffered prohibitive losses.

The only alternative was to operate under the cover of darkness. Guided by radio beacons, the Luftwaffe began their "Night Blitz" early in 1941. Your Monogram kit replicates an He III H-4 of KG 55 "Griffin Squadron", including formidable 1000 kg bombs, with temporary blacking sprayed over formerly light blue undersides. Another veteran of the Battle of Britain was KOG 26 "Lion Squadron", which was relocated to Sicily in the spring of 1941, far away from the deadly RAF fighters. As if intending to prove the versatility of the He III design, this unit was refitted as an anti-shipping squadron, operating in the Mediterranean Sea during the African Campaign. An He III H-5, including twin, externally mounted torpedoes, is the second version of your Monogram kit.

REVELL-MONOGRAM, INC. Morton Grove, IL Copyright © 1994. All rights reserved. Made in U.S.A.

5509M0200

If you have any problems building this model, call our modeling tips hotline at: **(800) 833-3570**



### READ THIS BEFORE YOU BEGIN

- Study the assembly drawings.
- Each plastic part is identified by a number.
- Let paint dry completely before handling parts.
- Check the fit of each piece before cementing into place.
- Do not use too much cement to join parts.
- Use only cement for polystyrene plastic.
- Model may be painted to match photos on box.
- Scrape paint from areas to be cemented.
- For better paint and decal adhesion, wash the plastic parts in a mild detergent solution.

### ALLGEMEINE HINWEISE

- Die Anordnung der Bauteile ist aus den Zeichnungen der Anleitung ersichtlich.
- Jedes Plastikteil ist durch eine Nummer gekennzeichnet.
- Die Teile vor dem Verkleben ungeleimt zusammenhalten, um ihren Passitz zu prüfen.
- Klebstoff nicht zu dick auftragen.
- Nur Modellbaukleber für Polystyrol verwenden.
- Man kann das Modell nach den Fotos auf der Schachtel anstreichen.

Monogram Models has put forth every effort to create and manufacture the finest model kit available. If a part may be missing, please write to:

**Monogram Model Kits**  
Consumer Service Department  
301 North Third Avenue  
Des Plaines, Illinois 60016

Be sure to include the kit number, part number, description, and your return address



**DECAL (DIP IN WATER)**  
DECALCOMANIA (MOJE CON AGUA)  
DECALCOMANIE (À PLONGER DANS L'EAU)  
ABZIEHBILD



**DO NOT CEMENT**  
NO USE PEGAMENTO  
NE PAS COLLER  
NICHT KLEBEN



**REMOVE AND THROW AWAY**  
QUITE Y TIRE  
À RETIRER ET JETER  
ENTFERNEN (ABFALL)



**OPTIONAL PARTS**  
PIEZAS OPCIONALES  
PIECES EN OPTION  
BAUTEILE NACH WAHL

- Bemalte Teile vor der Weiterverwendung gut trocknen lassen.
- Die Farbe muss von allen späteren Klebestellen abgeschabt werden.
- Damit die Farbe und die Abziehbilder besser kleben, sind die Plastikteile in einer milden Seifenlauge zu waschen. Dann abspülen und an der Luft trocknen lassen.

### LEA ESTO ANTES DE EMPEZAR

- Estudie los dibujos de ensamblaje.
- Cada pieza de plástico se identifica por un número.
- Verifique que cada pieza encaje bien antes de pegar en posición.
- No use demasiado pegamento para unir las piezas.
- Use únicamente pegamento para plástico de poliestirina.
- El modelo puede pintarse de acuerdo con las fotografías de la caja.
- Permita que se seque la pintura completamente antes de focar las piezas.
- Raspe la pintura de las superficies que serán pegadas.
- Para una mejor fijación la pintura y de las

calcomanías, lavense las piezas plasticase una solución de detergente suave. Enjuáguese y dejense secar al aire.

### LISEZ CE QUI SUIT AVANT DE COMMENCER LE MONTAGE

- Etudier les schémas d'assemblage.
- Chaque pièce plastique porte un numéro d'identification.
- Contrôler que chaque pièce soit bien conforme avant de la coller à sa place.
- N'utilisez pas trop de colle pour ré unir les pièces.
- Utilisez uniquement une colle spéciale pour polystyrène.
- Le modèle peut être conformément aux photos sur la boîte.
- Laissez sécher la peinture complètement, avant de manipuler les pièces
- Grattez la peinture sur les surfaces devant être collées.
- Pour assurer la meilleure adhésion possible de la peinture et des calcomanies, lavez les pièces de plastique avec une légère solution savonneuse. Rincer et laisser sécher à l'air.

FLAT BLACK	NOIR TERNE	NEGRO APAGADO	GLANZLOSES SCHWARZ
GLOSS WHITE	BLANC LUSTRE	BLANCO BRILLANTE	GLÄNZENDES WEISS
BROWN	BRUN	MARRON	BRAUN
GRAY	GRIS	GRIS	GRAU
DARK GRAY	GRIS FONCE	GRIS OSCURO	DUNKELGRAU
LIGHT GRAY	GRIS CLAIR	GRIS CLARO	HELLGRAU
DARK GREEN	VERT FONCE	VERDE OSCURO	DUNKELGRÜN
BLACK GREEN	VERT TRÈS FONCE	VERDE NEGRUZZO	SCHWARZGRÜN
LIGHT BLUE	BLEU CLAIR	AZUL CLARO	HELLBLAU
STEEL	METALLIC	METALLICO	METALLIC
SILVER	ARGENT	PLATA	SILBERN

## 1 COCKPIT ASSEMBLY

STEP

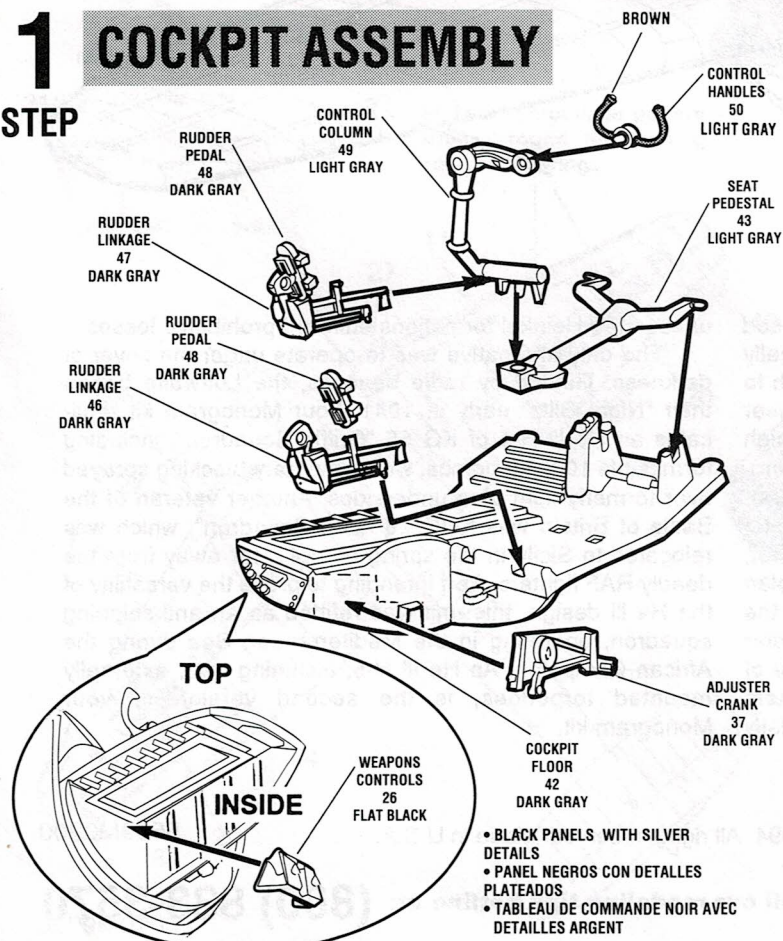

## 2 STEP

A COMPLETE GUIDE FOR PAINTING THIS AIRCRAFT APPEARS AT THE END OF THIS INSTRUCTION BOOKLET.

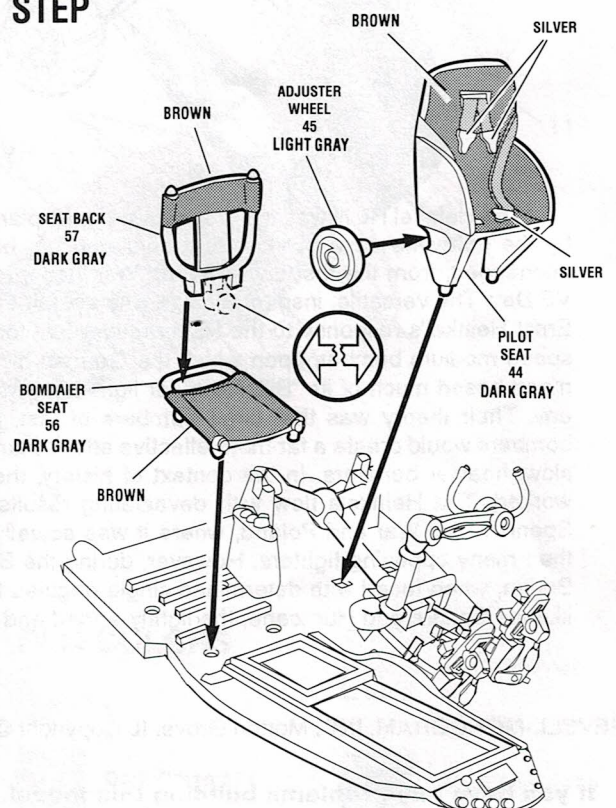



# 3 FUSELAGE ASSEMBLY

STEP

RIGHT SIDE

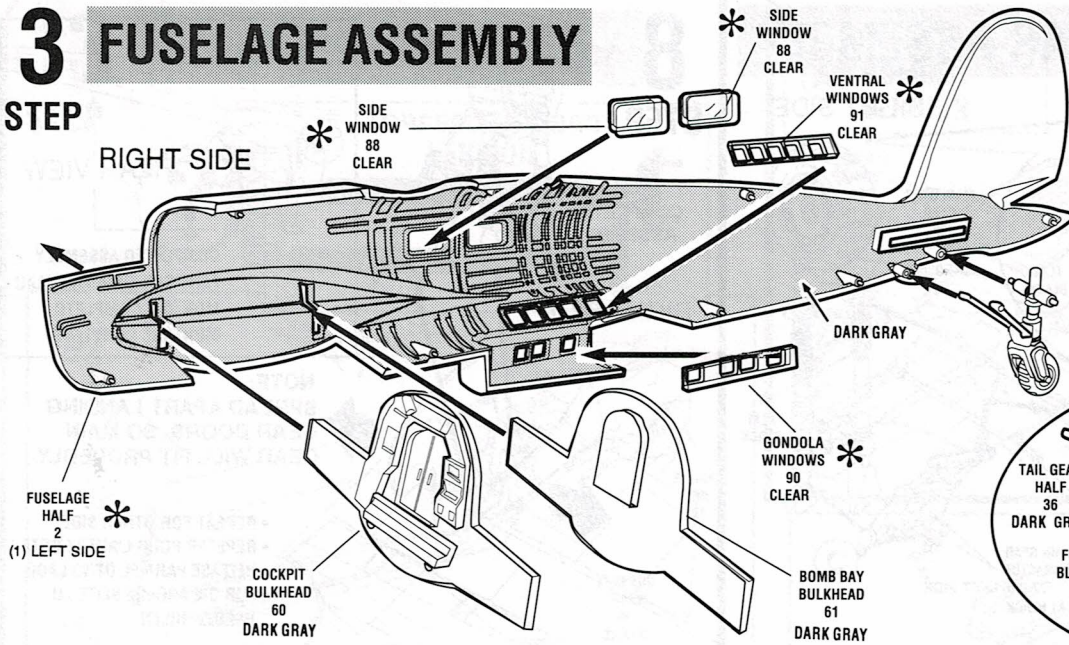

- \* REPEAT FOR OTHER SIDE
- \* REPETER POUR L'AUTRE COTE
- \* REITASE PARA EL OTRO LADO
- \* FUR DIE ANDERE SEITE ZU WIEDERHOLEN

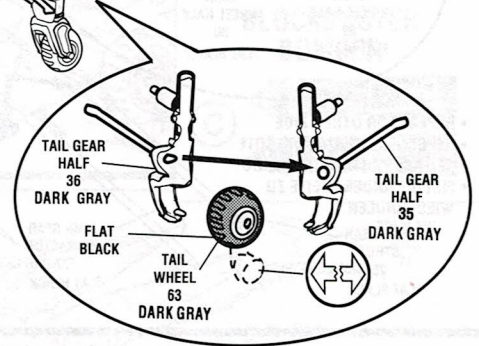

# 4

STEP

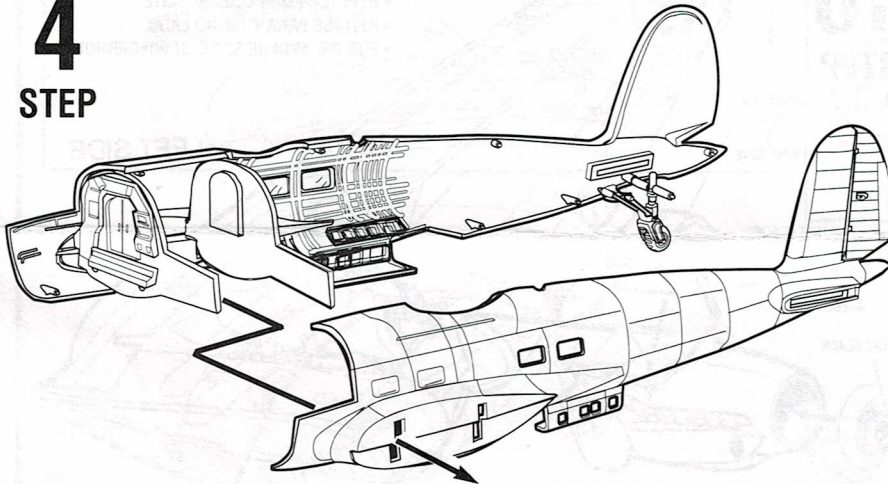

# 5 TAIL ASSEMBLY

STEP

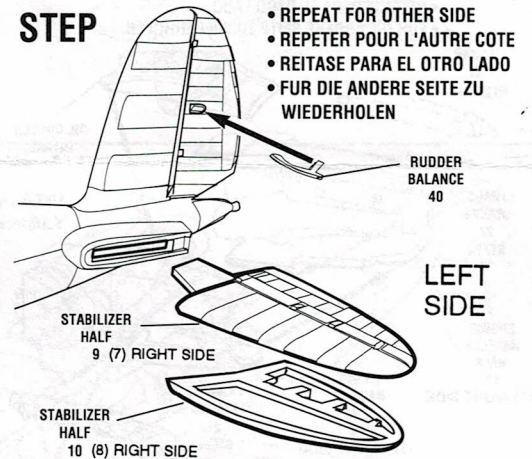

- \* REPEAT FOR OTHER SIDE
- \* REPETER POUR L'AUTRE COTE
- \* REITASE PARA EL OTRO LADO
- \* FUR DIE ANDERE SEITE ZU WIEDERHOLEN

# 6 WING ASSEMBLY

STEP

LEFT WING

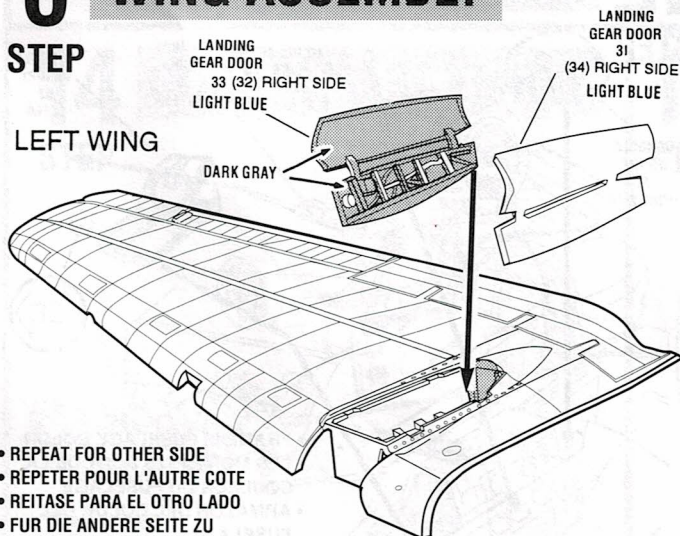

- \* REPEAT FOR OTHER SIDE
- \* REPETER POUR L'AUTRE COTE
- \* REITASE PARA EL OTRO LADO
- \* FUR DIE ANDERE SEITE ZU WIEDERHOLEN

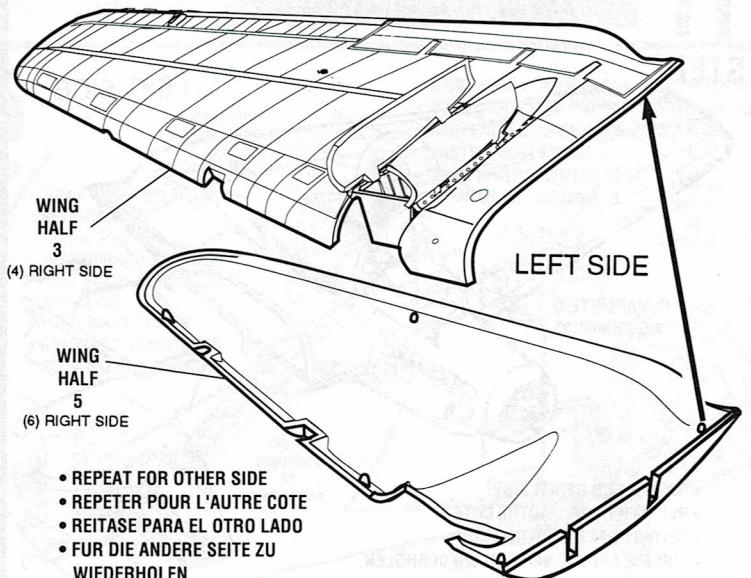

- \* REPEAT FOR OTHER SIDE
- \* REPETER POUR L'AUTRE COTE
- \* REITASE PARA EL OTRO LADO
- \* FUR DIE ANDERE SEITE ZU WIEDERHOLEN



# 7 LANDING GEAR ASSEMBLY

STEP

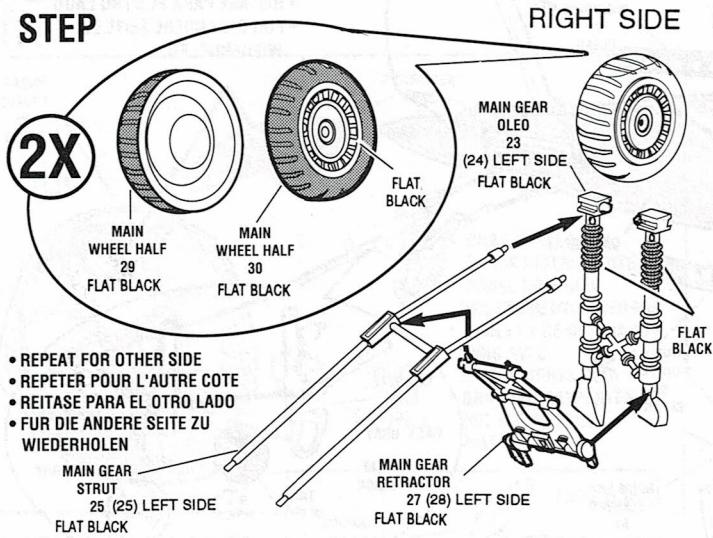

- REPEAT FOR OTHER SIDE
- REPETER POUR L'AUTRE COTE
- REITASE PARA EL OTRO LADO
- FUR DIE ANDERE SEITE ZU WIEDERHOLEN

# 8 STEP

COMPLETED ASSEMBLY

RIGHT SIDE

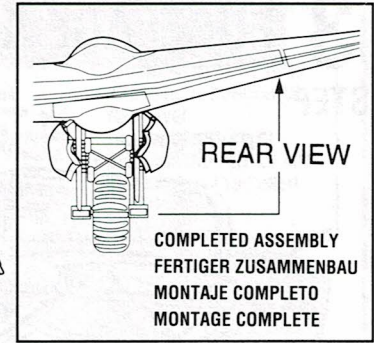
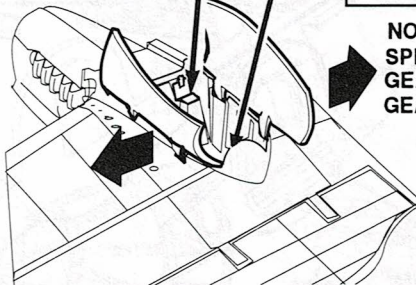

NOTE:  
SPREAD APART LANDING GEAR DOORS SO MAIN GEAR WILL FIT PROPERLY.

- REPEAT FOR OTHER SIDE
- REPETER POUR L'AUTRE COTE
- REITASE PARA EL OTRO LADO
- FUR DIE ANDERE SEITE ZU WIEDERHOLEN

# 9 ENGINE ASSEMBLY

STEP

LEFT SIDE

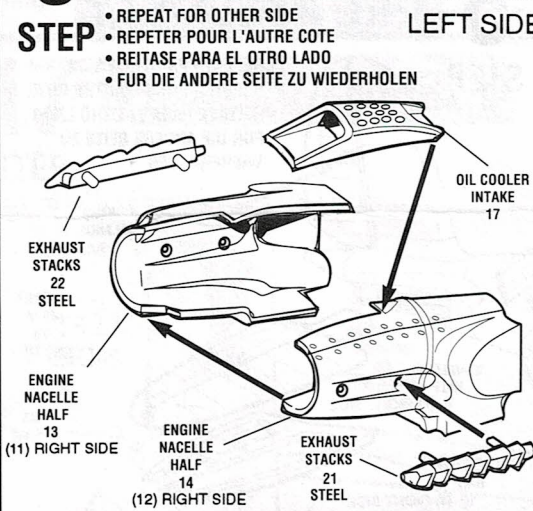

- REPEAT FOR OTHER SIDE
- REPETER POUR L'AUTRE COTE
- REITASE PARA EL OTRO LADO
- FUR DIE ANDERE SEITE ZU WIEDERHOLEN

# 10 STEP

LEFT SIDE

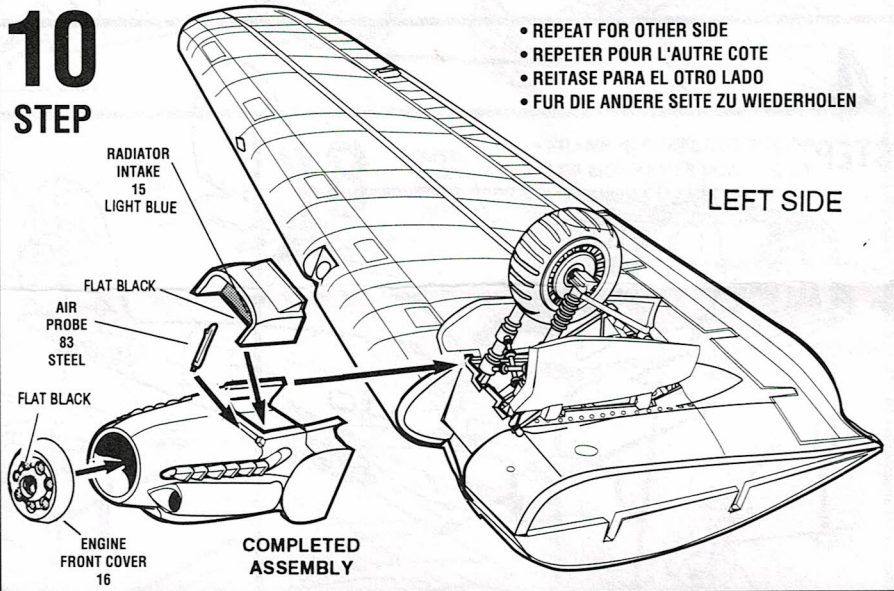

- REPEAT FOR OTHER SIDE
- REPETER POUR L'AUTRE COTE
- REITASE PARA EL OTRO LADO
- FUR DIE ANDERE SEITE ZU WIEDERHOLEN

# 11 WING ASSEMBLY

STEP

LEFT SIDE

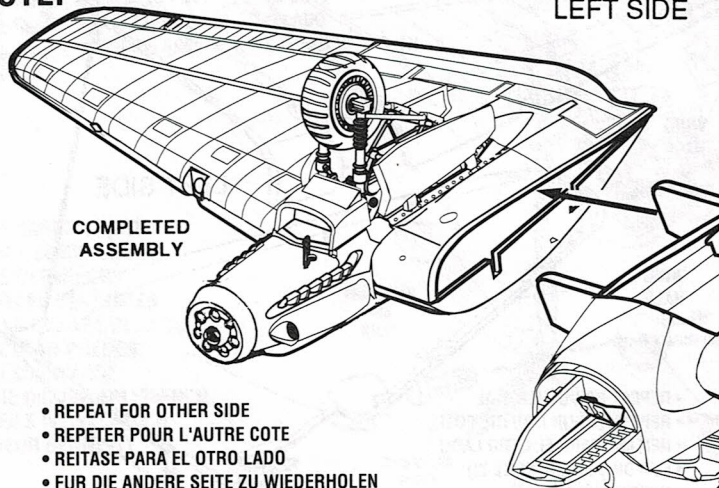

- REPEAT FOR OTHER SIDE
- REPETER POUR L'AUTRE COTE
- REITASE PARA EL OTRO LADO
- FUR DIE ANDERE SEITE ZU WIEDERHOLEN

# 12 VENTRAL ASSEMBLY

STEP

GONDOLA FRONT 71 LIGHT BLUE

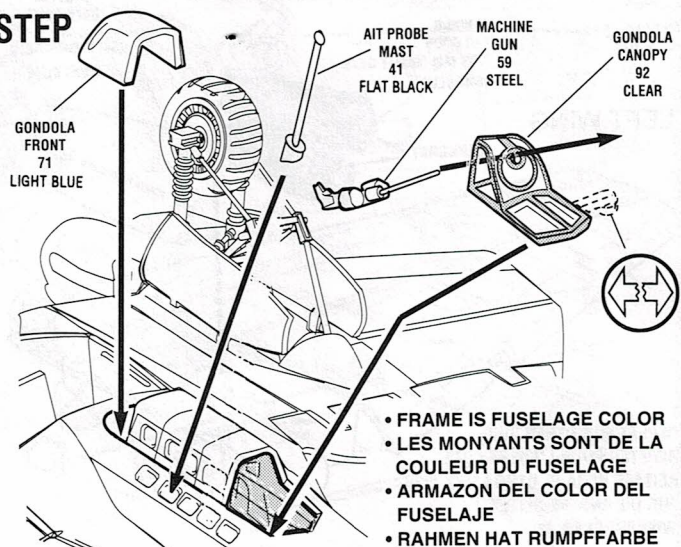

- FRAME IS FUSELAGE COLOR
- LES MONYANTS SONT DE LA COULEUR DU FUSELAGE
- ARMAZON DEL COLOR DEL FUSELAJE
- RAHMEN HAT RUMPPFARBE



# 13 WEAPONS ASSEMBLY

STEP

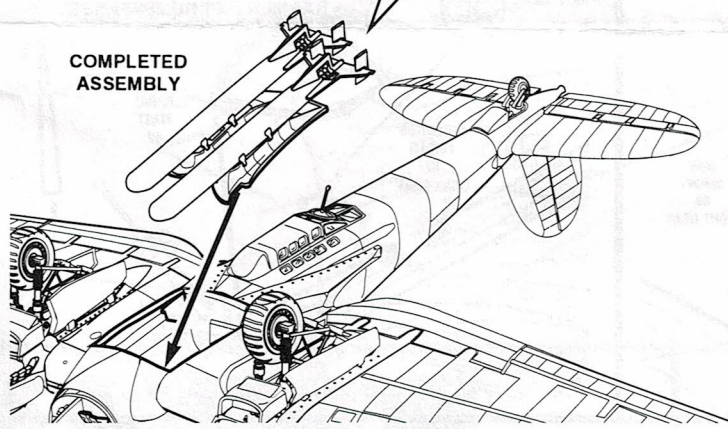
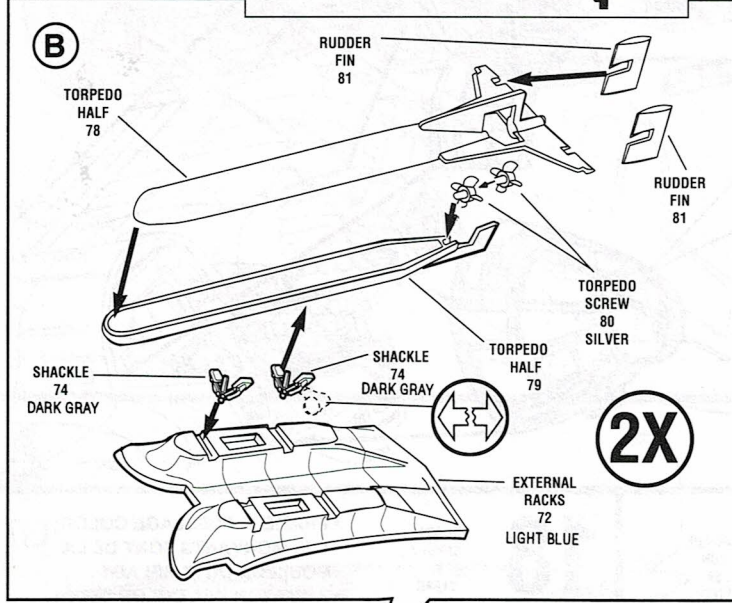
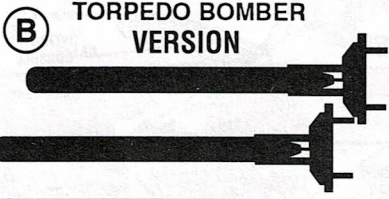

## A STANDARD BOMBER VERSION

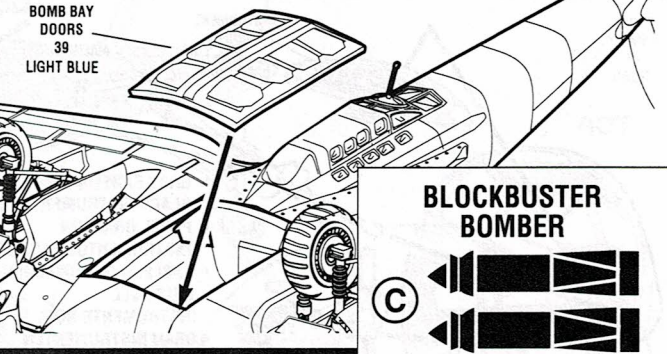

## C BLOCKBUSTER BOMBER

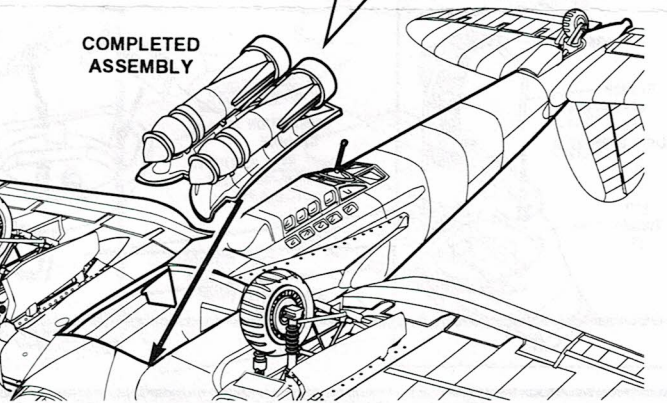
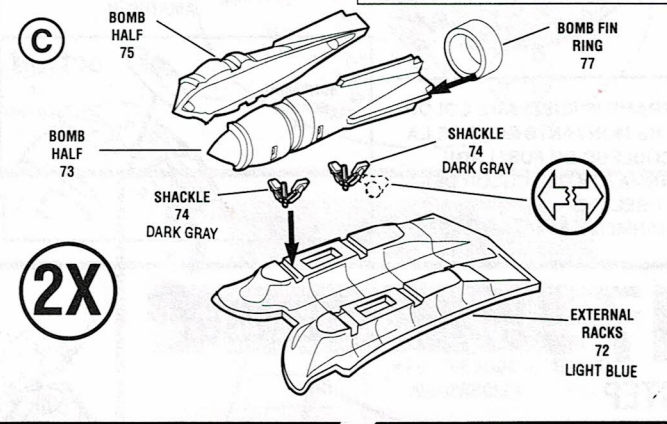

# 14 COCKPIT ASSEMBLY

STEP

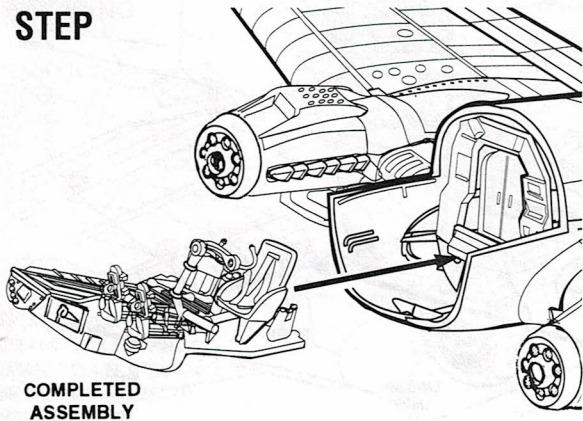

# 15

STEP

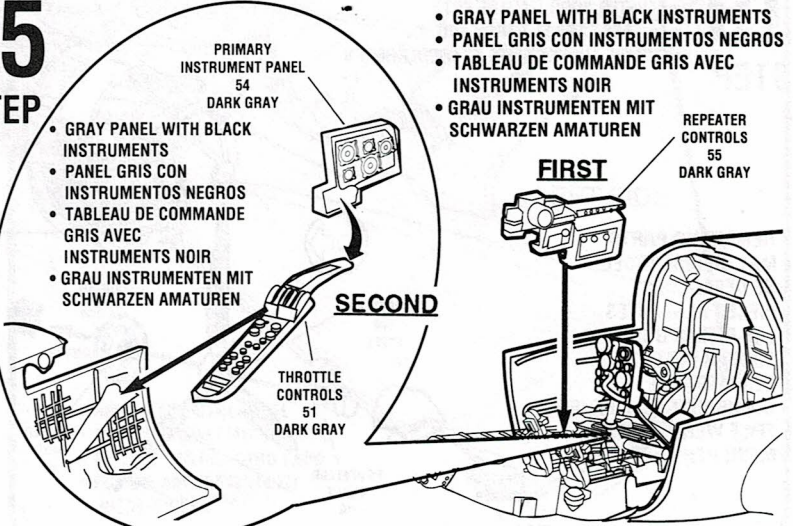



# 16 CANOPY ASSEMBLY

STEP

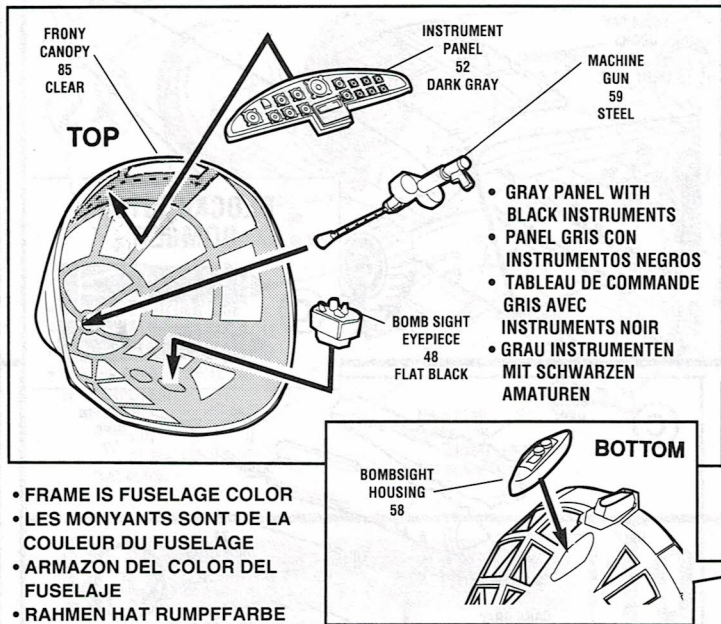

- FRAME IS FUSELAGE COLOR
- LES MONYANTS SONT DE LA COULEUR DU FUSELAGE
- ARMAZON DEL COLOR DEL FUSELAJE
- RAHMEN HAT RUMPFARBE

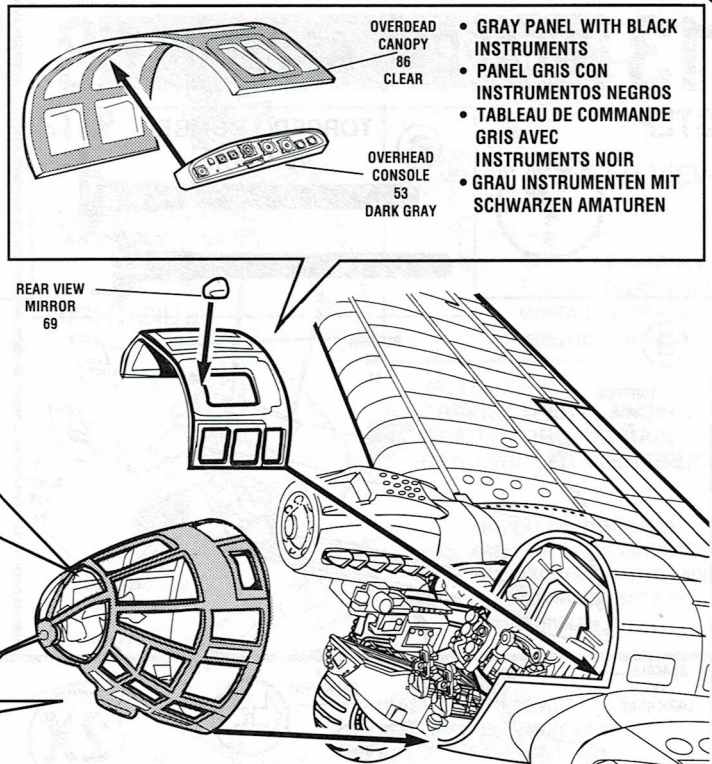

# 17 FINAL ASSEMBLY

STEP

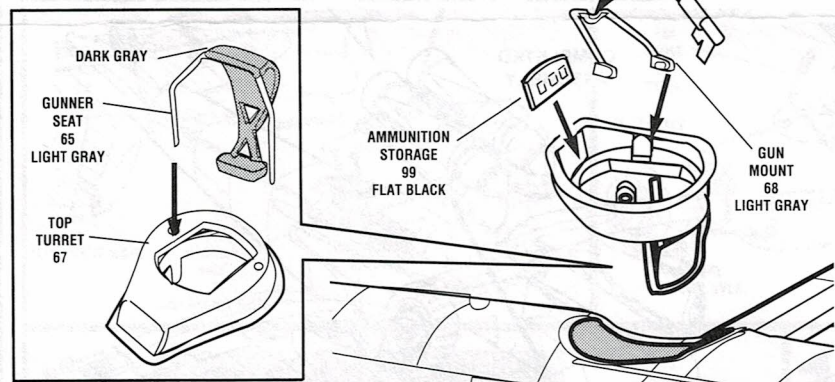

# 18 STEP

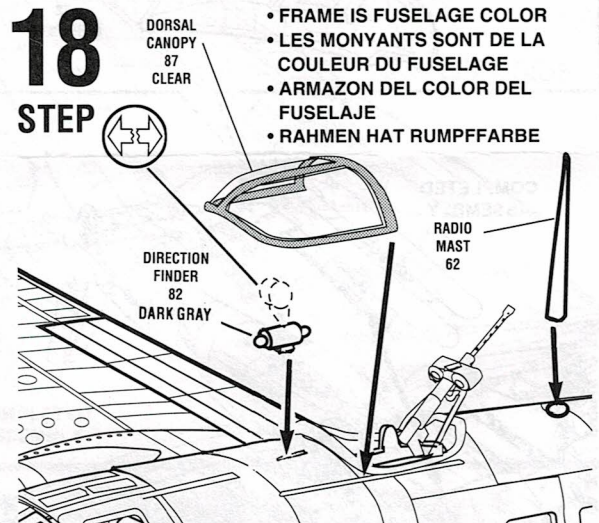

# 19 STEP

- REPEAT FOR OTHER SIDE
- REPETER POUR L'AUTRE COTE
- REITASE PARA EL OTRO LADO
- FUR DIE ANDERE SEITE ZU WIEDERHOLEN

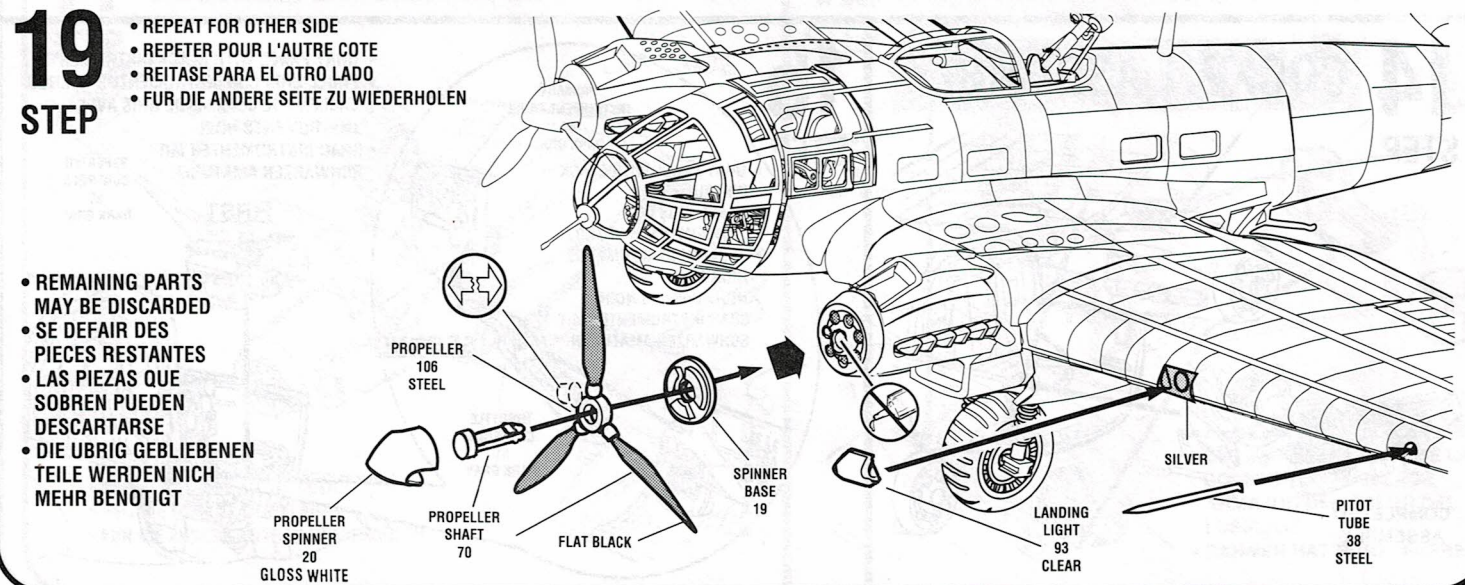





# APPLY DECALS

Heinkel He III H-4 of 8./KG 55 on night intruder mission "Fledermaus" operated from Deux, France, 1941 during the Battle of Britain.

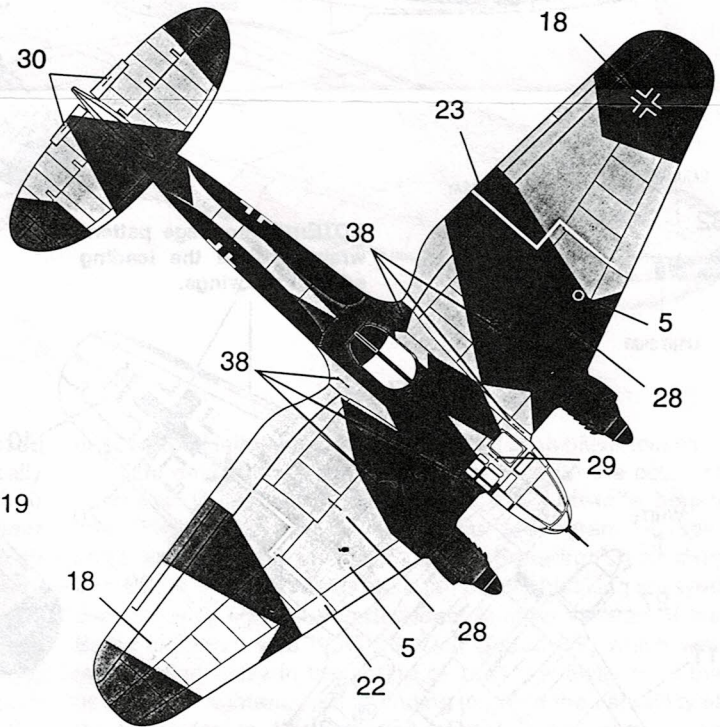
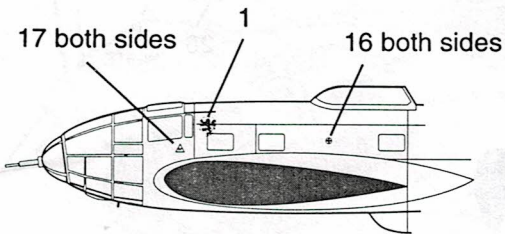
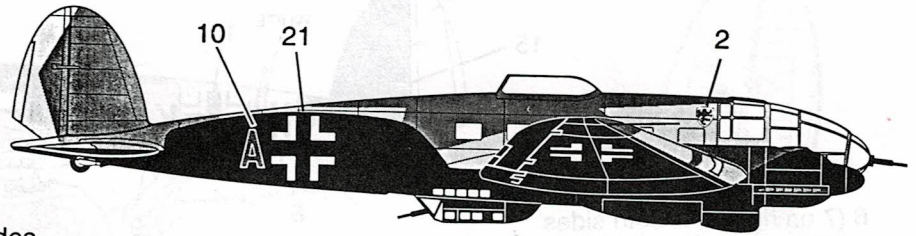
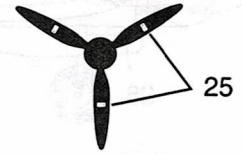
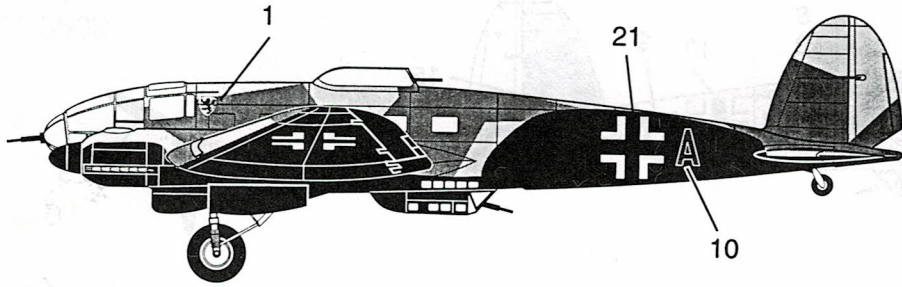

SIDE VIEW

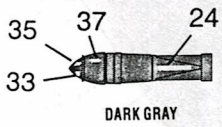

NOTE:: Camouflage pattern wraps around the leading edge of the wings.

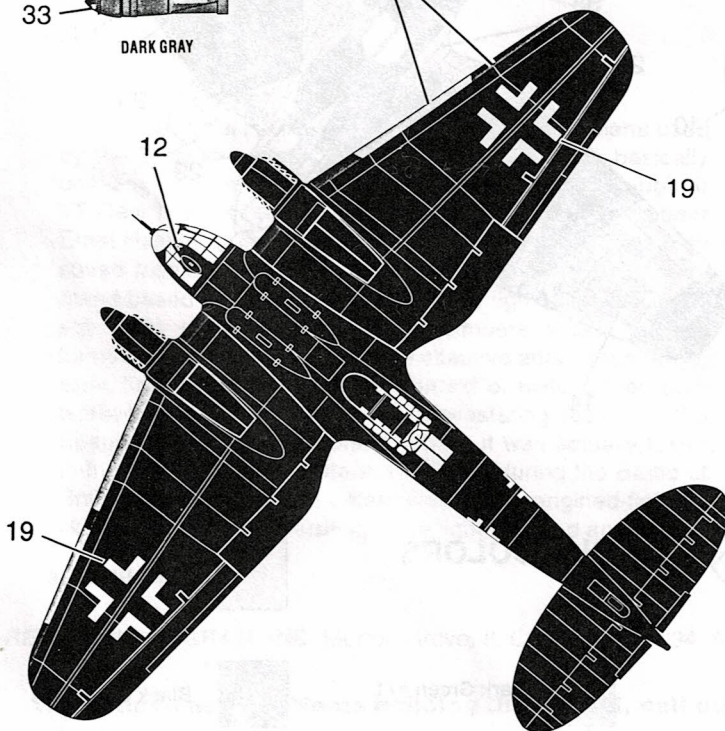

## RLM COLORS



Matte Black



Dark Green #71



Black Green #70





# APPLY DECALS

Heinkel He III H-5 of II/KG 26,  
Grosseto, Italy, 1941

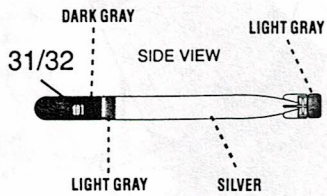
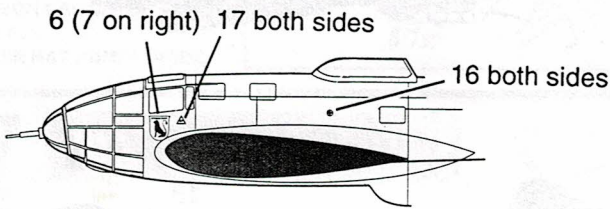
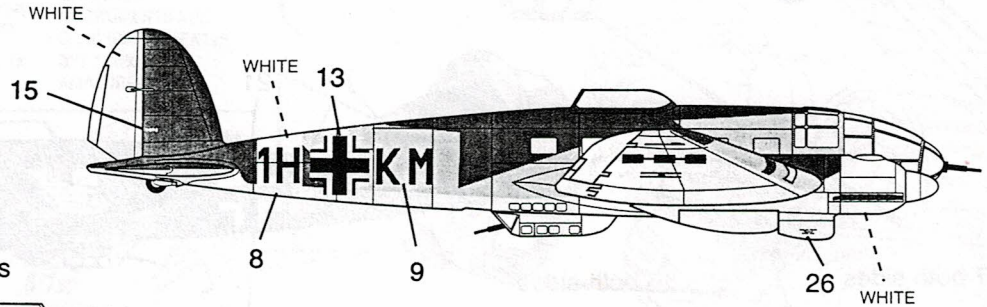
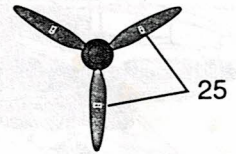
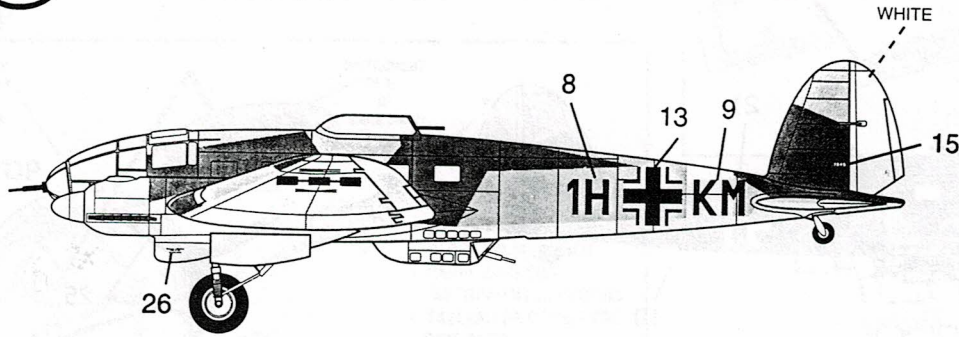

**NOTE::** Camouflage pattern wraps around the leading edge of the wings.

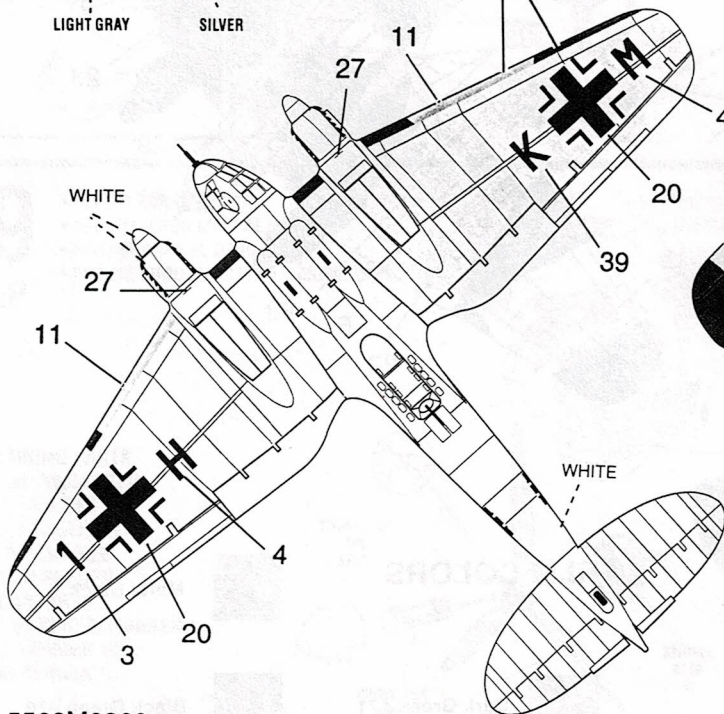
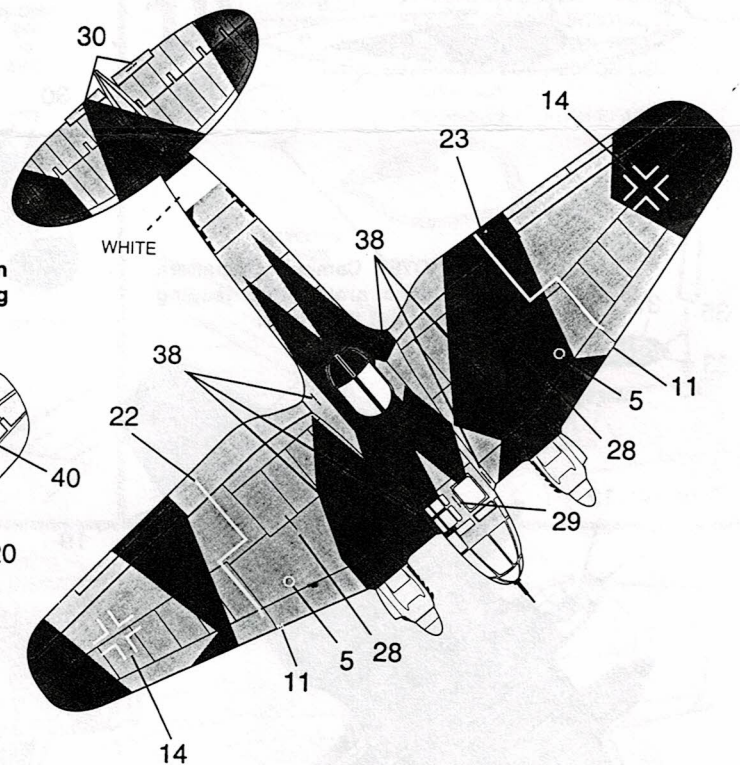

## RLM COLORS

	Light Blue #65
	Dark Green #71
	Black Green #70