



BRONCO

Bronco Models

Curtiss P-40C (Hawk 81-A2) Fighter -AVG 'Flying Tigers'

寇蒂斯P-40C (霍克81A-2) 战斗机 (飞虎队) **1/48 Scale**



1937 Curtiss changed Allison V-1710-19 liquid cooled engine in a p36 fighter. The plane of the military project code is XP-40. The aircraft first flew successfully in October of the following year and reached a maximum speed of 587 km. In April 1939, the U.S. Army ordered the P-40A to start production and in a number of years have been changed out of type B and C. The P-40C (Hawk81 A-2) to increase the self sealing fuel tank based on type B, effectively improve the comprehensive protection of the fuel system. At the same time also increased the rack to Ground Weapons. Two weapons including a 12.7 mm machine gun and 4 wing was on a 7.62 mm gun. After the outbreak of World War II, the British government purchased a large number of military aircraft to the United States, including 930 P-40C, called the Tomahawk MK.IIB. The United States Army Air force is also equipped with 193 aircraft P-40C. The Chinese air force in early 1941 purchased 100 aircraft for the British production of the Tomahawk MK.IIB, all equipped the American Volunteer Group, they known as the "Flying Tigers". They painted the shark nose with a bloody mouth and the side of the fuselage painted winged tiger image P-40 aircraft world. At the beginning of the dark days of the outbreak of the war in the Pacific, the weak air power to undertake the task of Anti-Japanese air defense operations in southwest of China. Relying on the excellent performance and the formation of tactical P-40C has achieved great success in Kunming, Yangon and other places of air combat. The army also emerged such as Dick Rossi, Charles Odell and several other ACE. As a world-class elite fighter, P-40C made outstanding contributions to the Anti Japanese War China.

1937 年寇蒂斯公司将其先前研发的一架 P36 战斗机换装艾利森 V-1710-19 液冷发动机, 这架飞机的军方项目代号是 XP-40。该机于次年 10 月首飞成功并达到了 587 公里的最高时速。1939 年 4 月, 美国陆军订购的 P-40A 型开始投产并在之后数年内相继改进出 B 和 C 型。其中 P-40C 型 (也称 Hawk81 A-2) 在 B 型的基础上增加自封油箱, 有效提高了燃料系统的全面防护。同时还增加了对地武器挂架。武器为两挺 12.7 毫米机头机枪和 4 挺主翼上的 7.62 毫米机枪。二战爆发后, 英国政府向美国购买了大批军机, 其中就包括 930 架 P-40C 型, 称为战斧 MK.IIB。另外美国陆军航空队也装备了 193 架 P-40C。中国空军于 1941 年初购得 100 架为英国生产的战斧 MK.IIB, 全部装备美国志愿援华航空队, 也就是后来著名的“飞虎队”。他们以机首涂着鲨鱼血盆大口和机身侧面绘有带翅膀的老虎形象的 P-40 飞机为世人所瞩目。在太平洋战争爆发初期的黑暗岁月, 这支弱小的空中力量担负起中国西南地区的对日防空作战任务, 依靠 P-40C 优良的性能和编队战术取得了昆明、仰光等地多次空战的重大胜利。该部队也涌现出如迪克·罗西、查尔斯·奥德尔等多名王牌。作为一款世界级的优秀战斗机, P-40C 为中国抗战做出了卓越贡献。



中文

ILLUSTRATION 图示说明:

CORRECT METHOD FOR APPLYING DECALS: 正确贴水贴纸的方法:

1. Clean model parts surface with wet cloth.
将需要贴水贴纸之部位表面擦干净。
2. Cut out the decal parts and dip them in cold water for 15 ~20 seconds.
将所需之贴纸剪下泡在清水里约15至20秒。
3. Place it on correct position of the model kit.
将湿透之贴纸取出置放于正确之位置旁。
4. Slide off the decal from the base paper on to the model kit surface with a cotton stick.
用棉花棒轻推贴纸表面使其从底纸滑出至模型表面之正确位置。
5. When decal get dry then complete.
待其自然干透后即完成。

ICON INSTRUCTION: 图标说明:



Open Hole
钻孔



Remove
切除



2 Sets needed
同样的制作二组



Bend
曲折



Optional
可以选择采用



Apply Decal
贴水贴纸



Instant Glue For Metal
瞬间接着剂,金属用



Fill Hole
把孔填平



Do not cement
不用粘合

COLOR SUGGESTION: 涂装指引:

Color 涂料表	MR. Hobby	Hobby Color	Humbrol	Tamiya
Red 红色	H-3	C-3	153	XF-7
Yellow 黄色	H-4	C-4	99	XF-3
Silver 银色	H-8	C-8	11	X-11
Neutral Gray 天灰色	H-22	C-13	126	XF-20
Middle Stone 中石色	H-71	C-21	41	XF-49: 1+XF-60: 1
Dark Green 墨绿色	H-73	C-23	60	XF-81
Steel 黑铁色	H-18	C-28	201	X-10
Dark Gray 暗灰色	H-83	C-32	67	XF-24
Flat Black 亚光黑色	H-12	C-33	133	XF-1
Sky Blue 天蓝色	H-25	C-34	/	XF-2: 1+XF-18: 1
Red Brown 红棕色	H-47	C-41	/	XF-64
Tan 暗黄色	H-27	C-44	61	XF-60
Sail Color 帆布色	H-85	C-45	47	XF-49
Clear Red 透明红色	H-90	C-47	160	X-27
Clear Blue 透明蓝色	H-93	C-50	/	X-23
Khaki Green 卡其绿色	H-80	C-54	/	/
Burnt Iron 烧铁色	H-76	C-41	/	X-56: 3+XF-64: 1
Flat White 亚光白色	H-11	C-62	/	XF-2
Metal Black 金属黑色	H-28	C-78	66	X-18: 1+XF-56: 2
Semi Gloss Black 半光泽黑色	/	C-92	/	X-18
Tire Black 胎黑色	/	C-137	/	X-85
Interior Green 内舱黄绿色	/	C-351	/	/

READ BEFORE ASSEMBLING: 组装必读:

- Carefully Study instruction before assembling. 组装前请阅读清楚制作指引。
- Keep plastic model glue and tools away from children. 胶水,油漆及工具勿让小孩接触。
- Do not use cement or paint near open flame or sparks. 胶水及油漆勿接触火种。
- Do not work in closed room. 勿在密封地方制作模型。

Printed in China

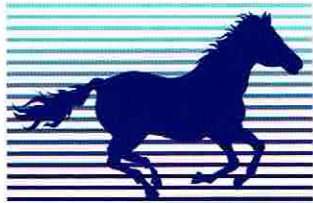

BRONCO

Bronco Models

Copyright © 2016

Made in China

中国制造

No use parts
不要部件



(A) × 1

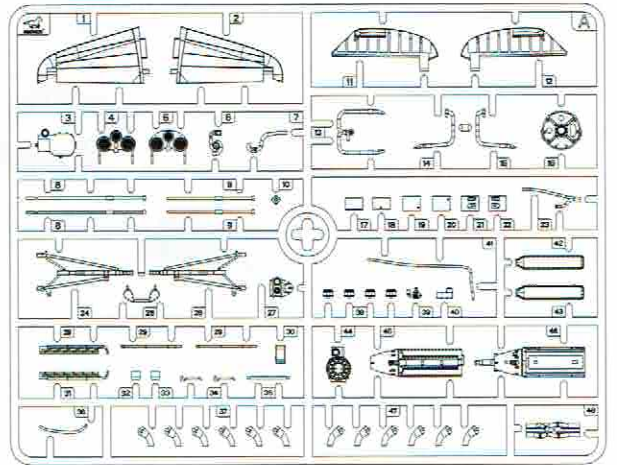

(C) × 1

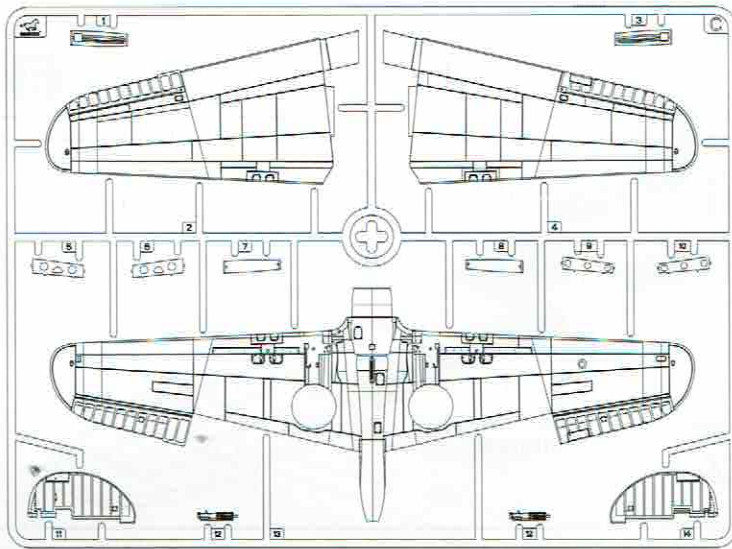

(B) × 1

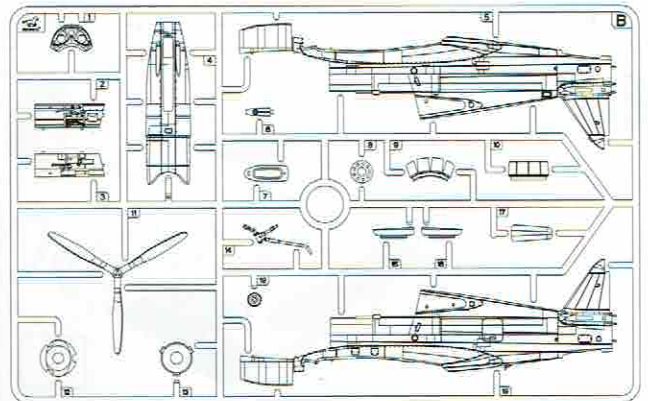

(D) × 1

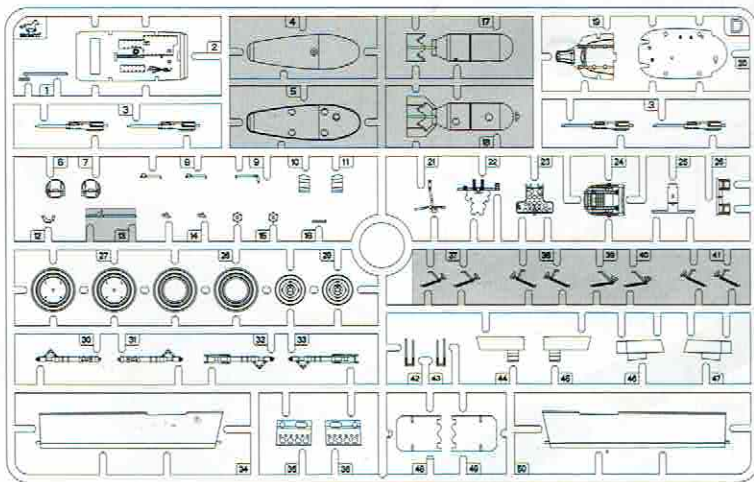

DECAL × 1

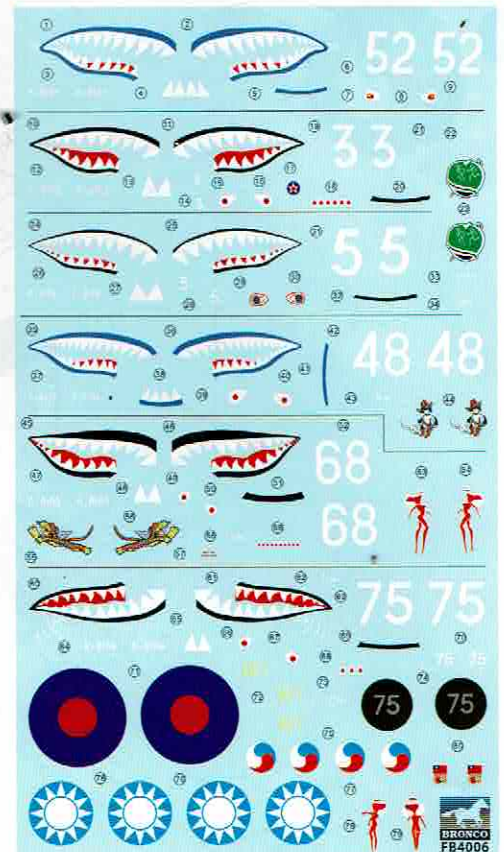

(E) × 1

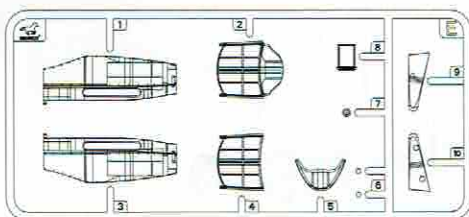

(P) × 1



FB4006

1

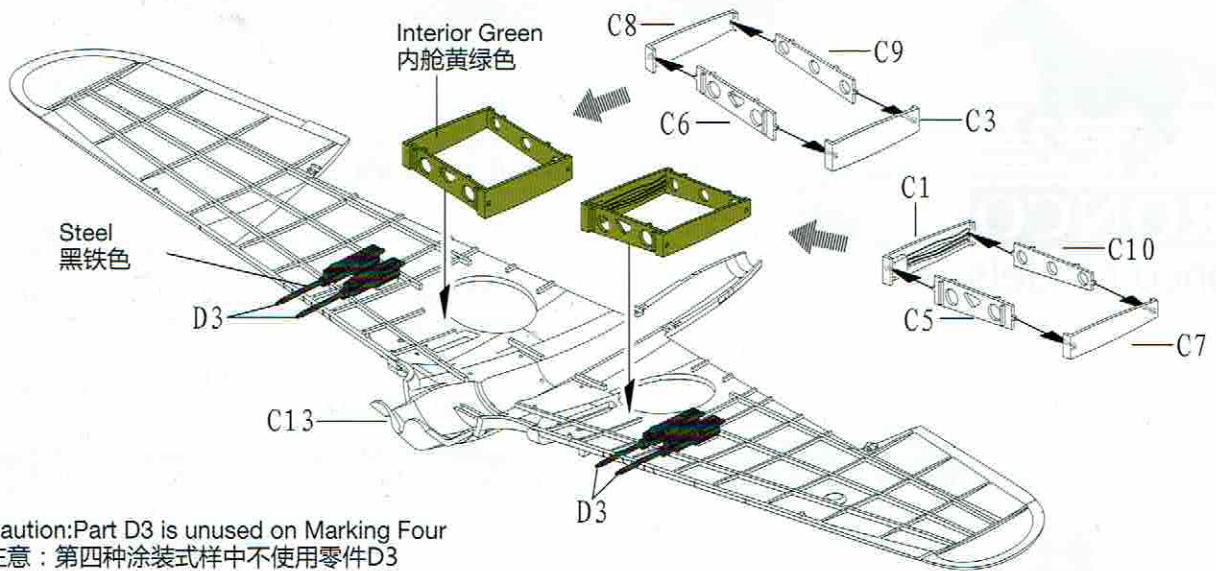

★ Caution: Part D3 is unused on Marking Four
 注意：第四种涂装式样中不使用零件D3

2

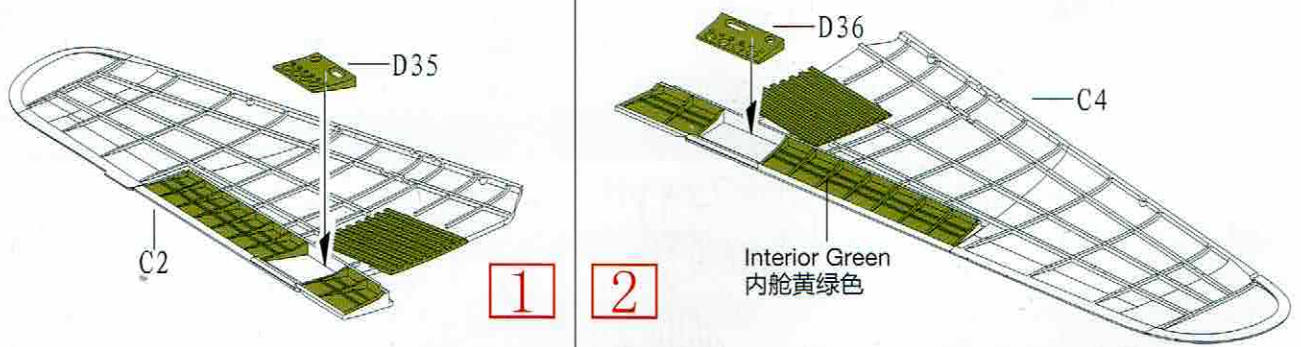

3

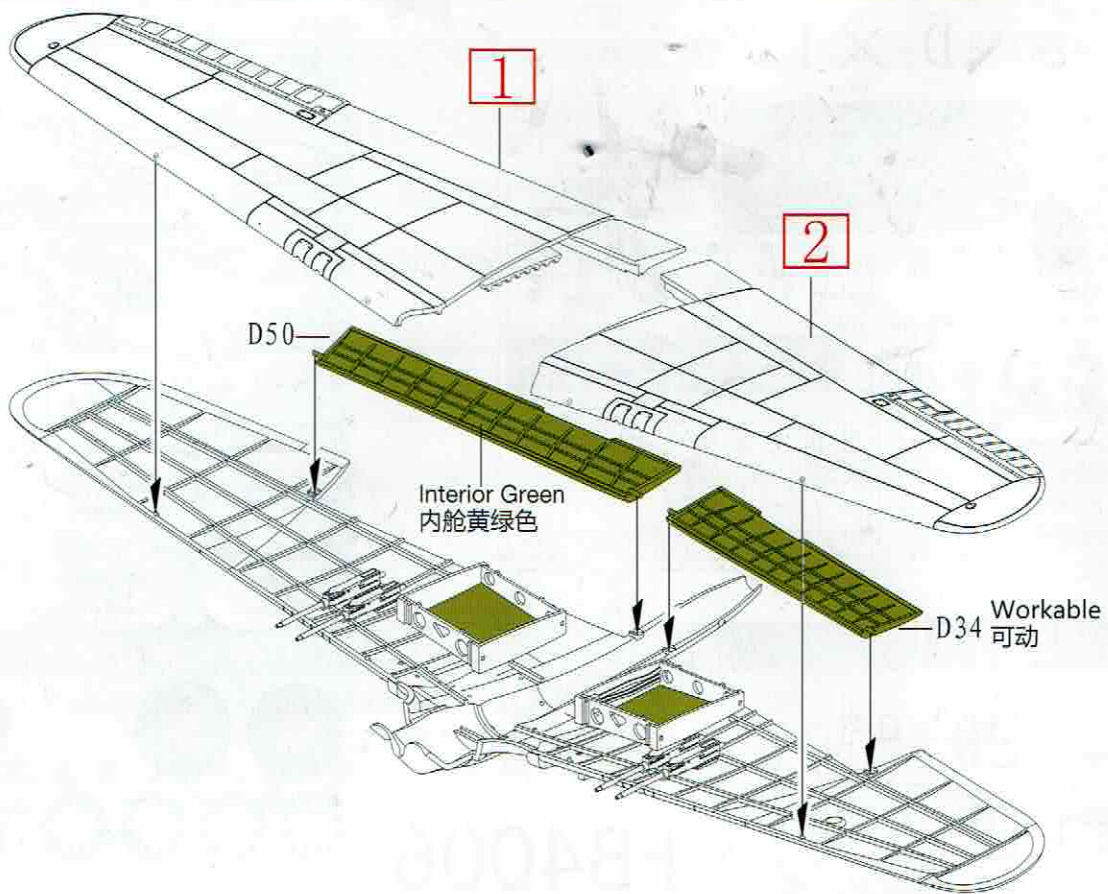

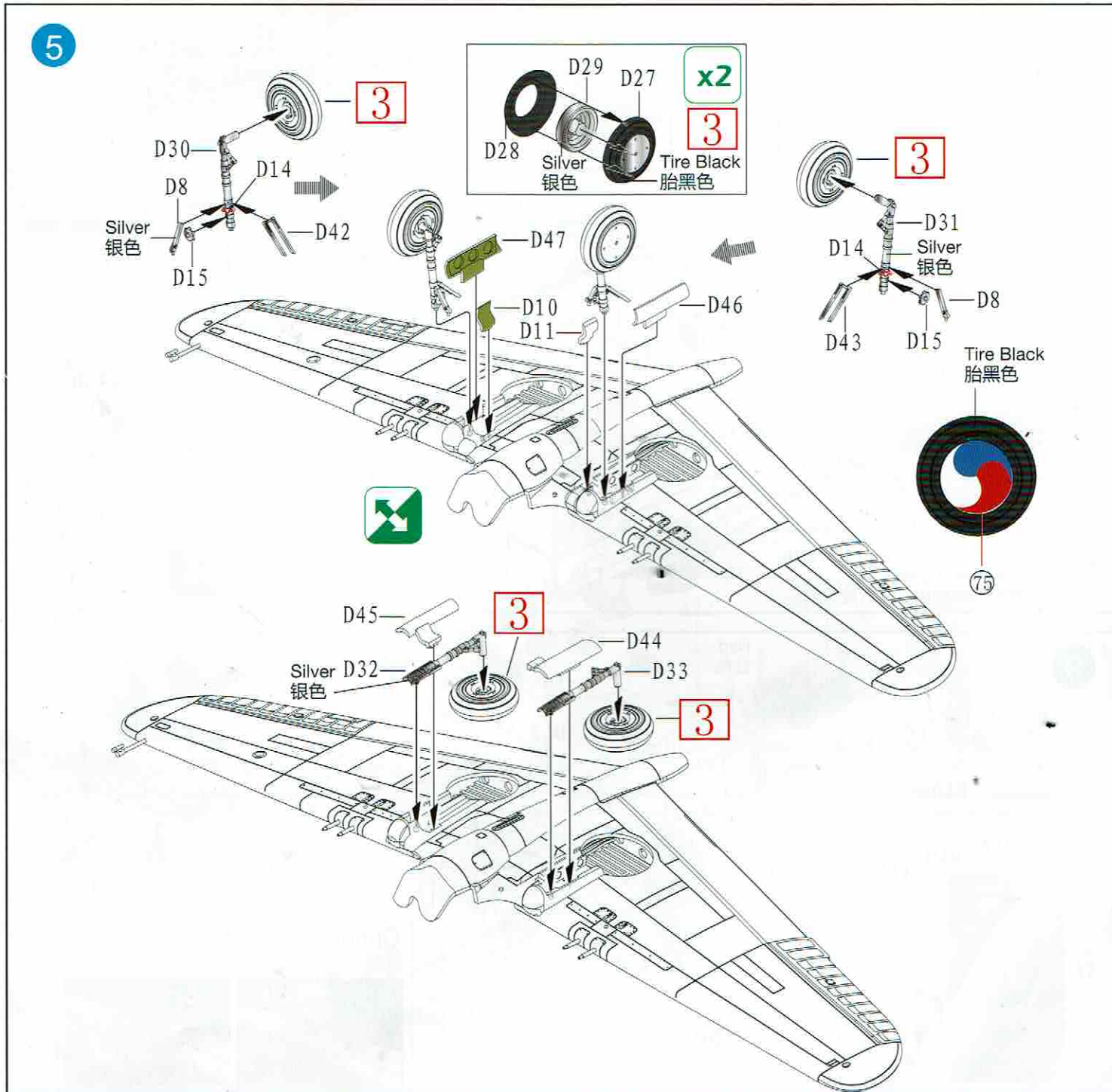
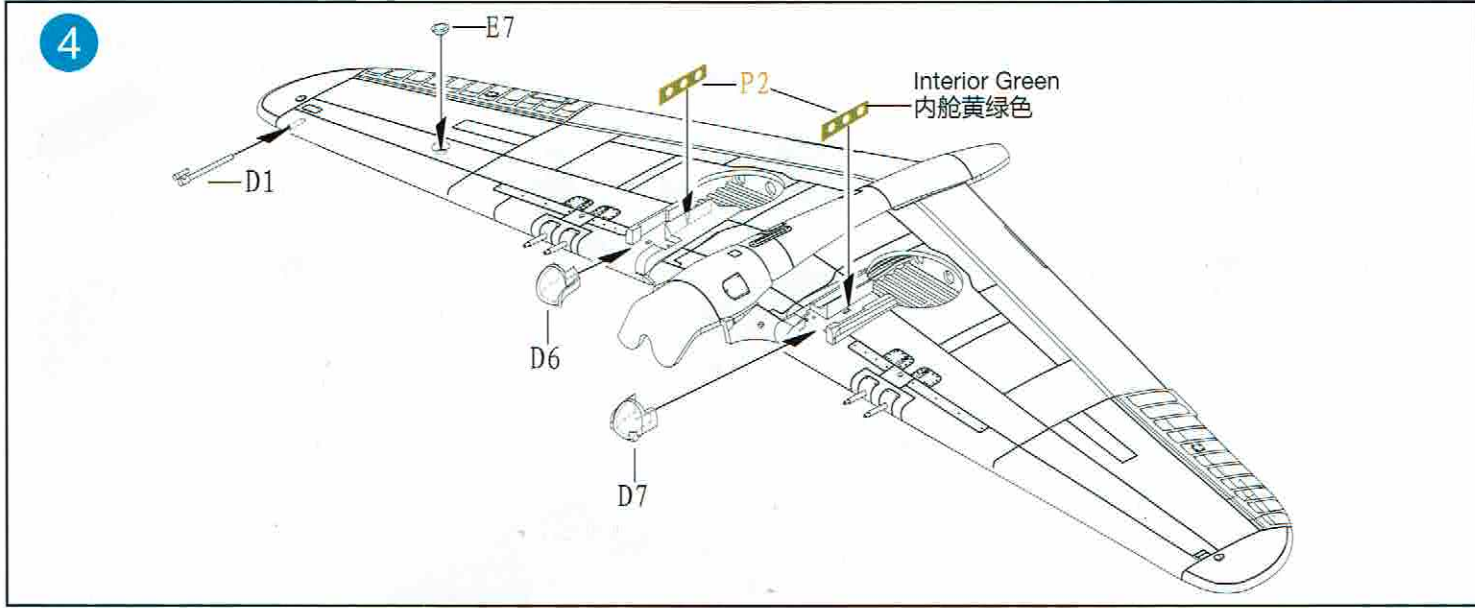
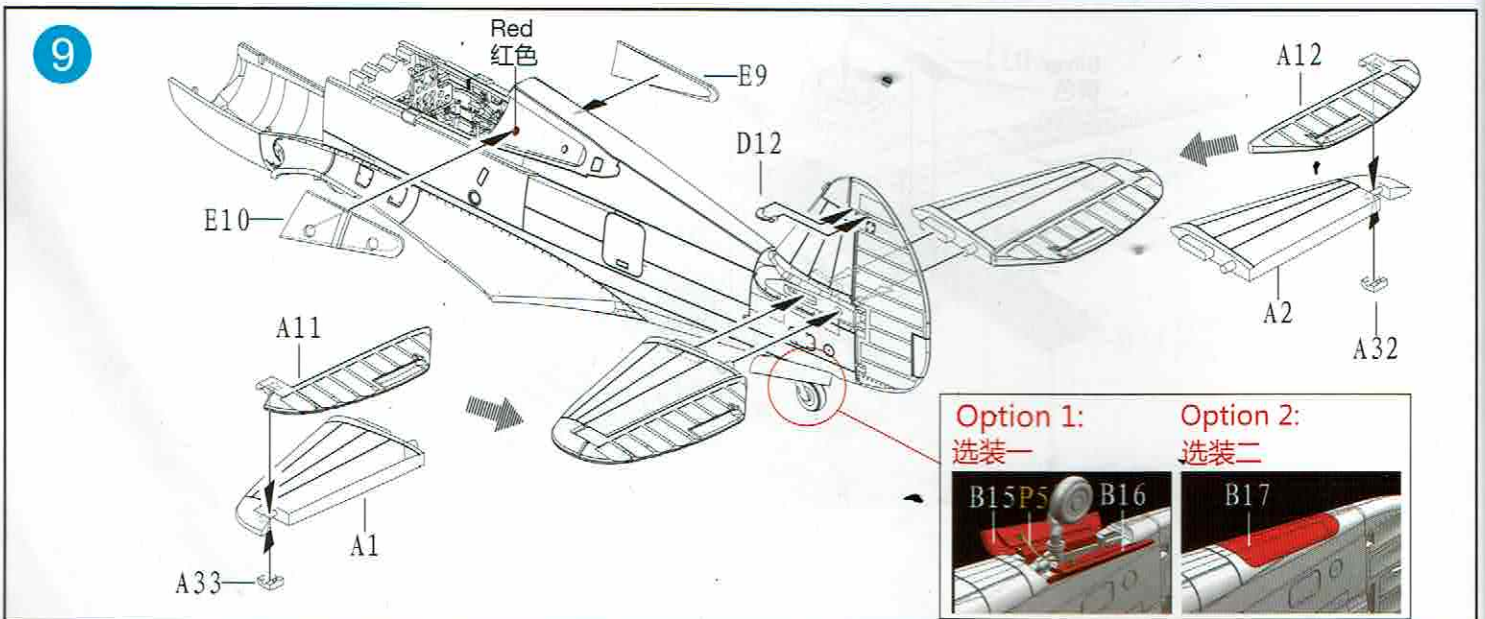
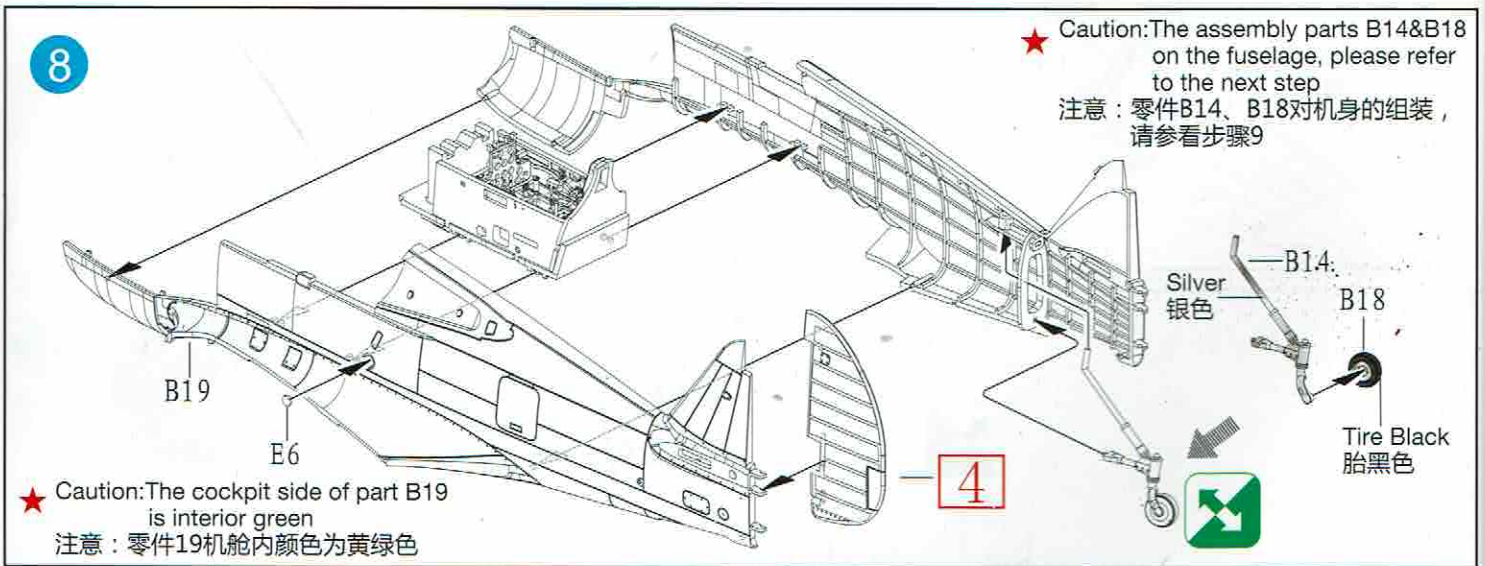
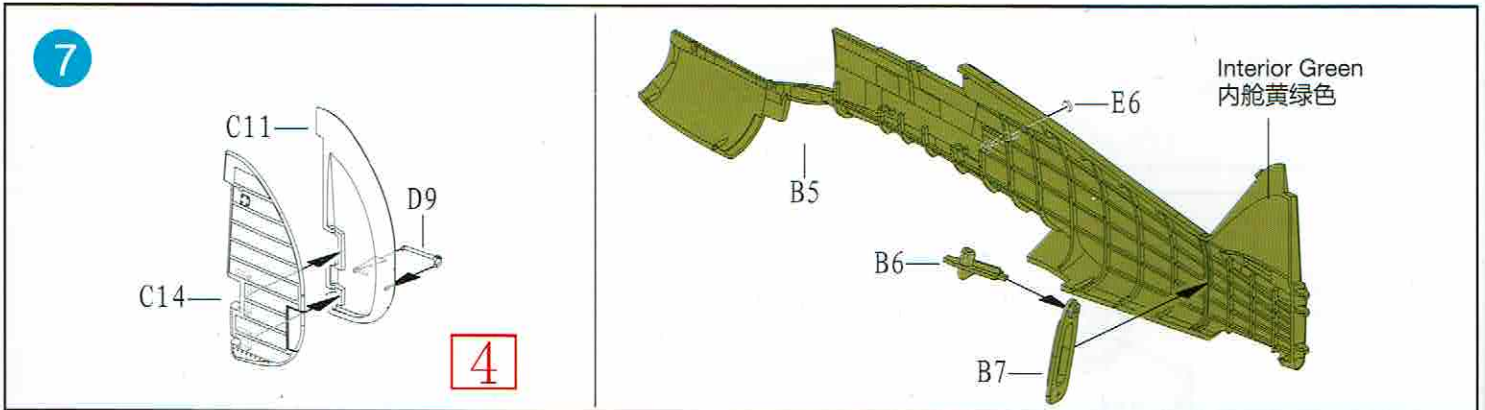
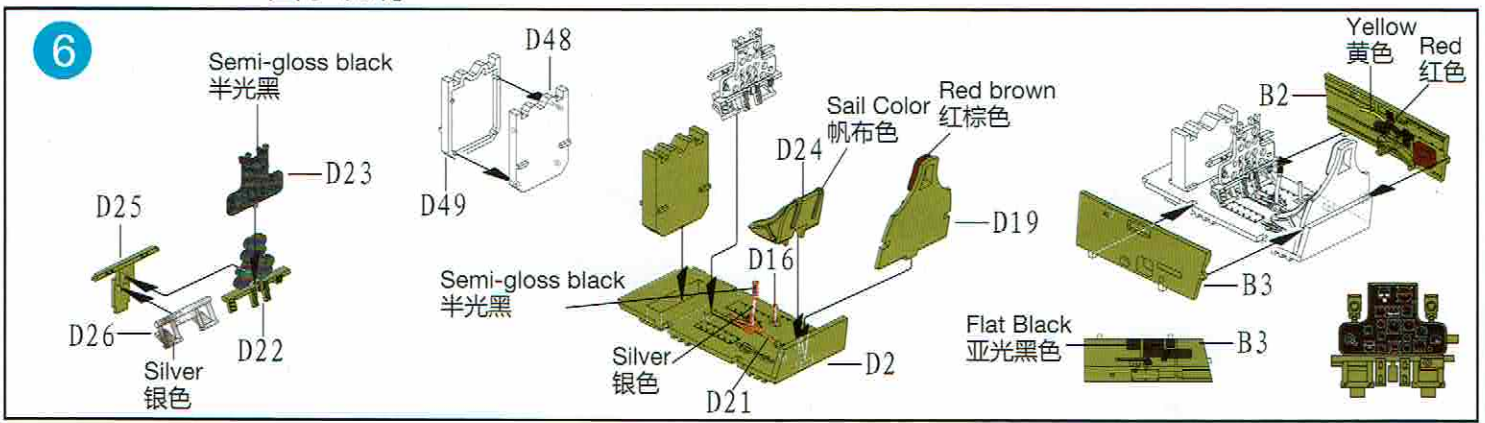
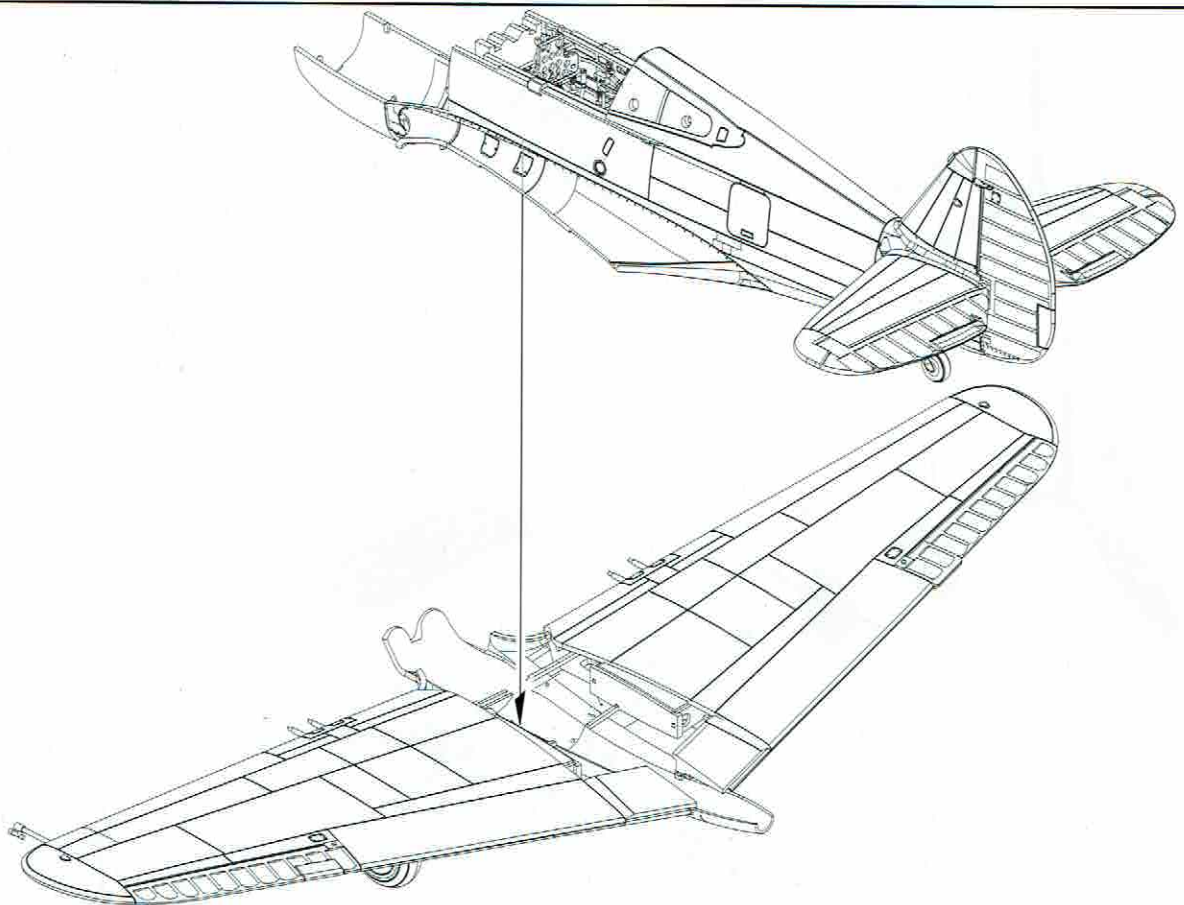

ILLUSTRATION 图示说明：



10



11

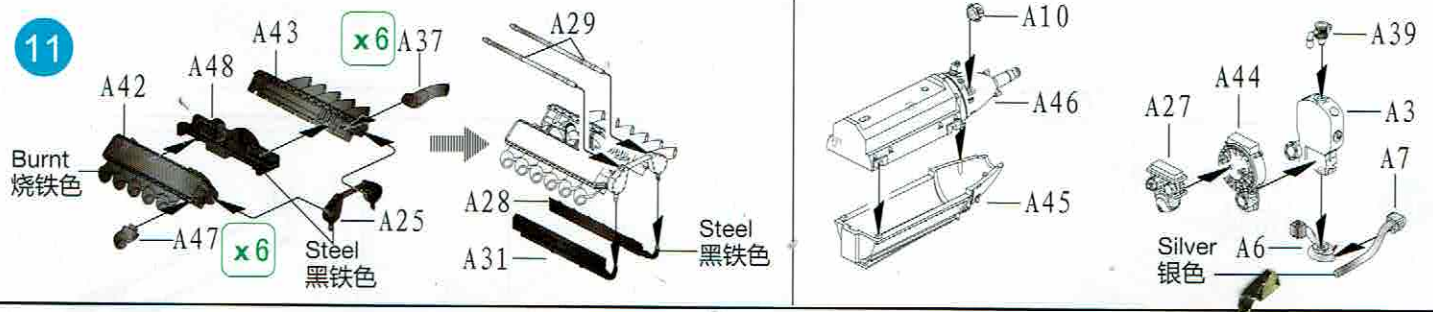

12

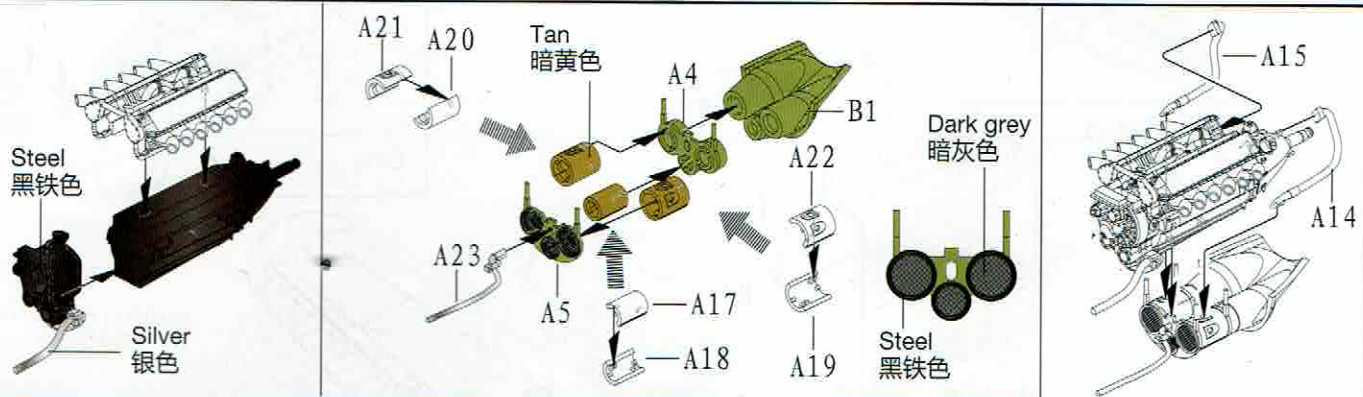

13

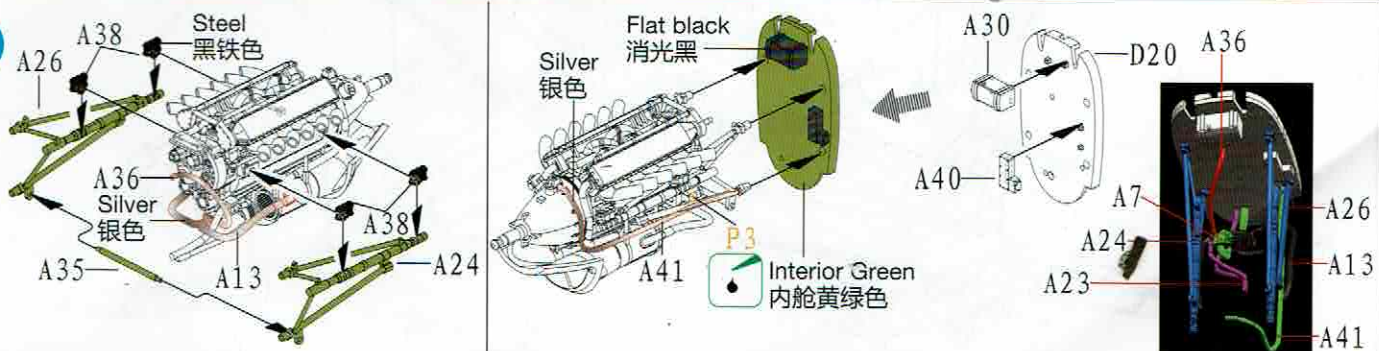

14

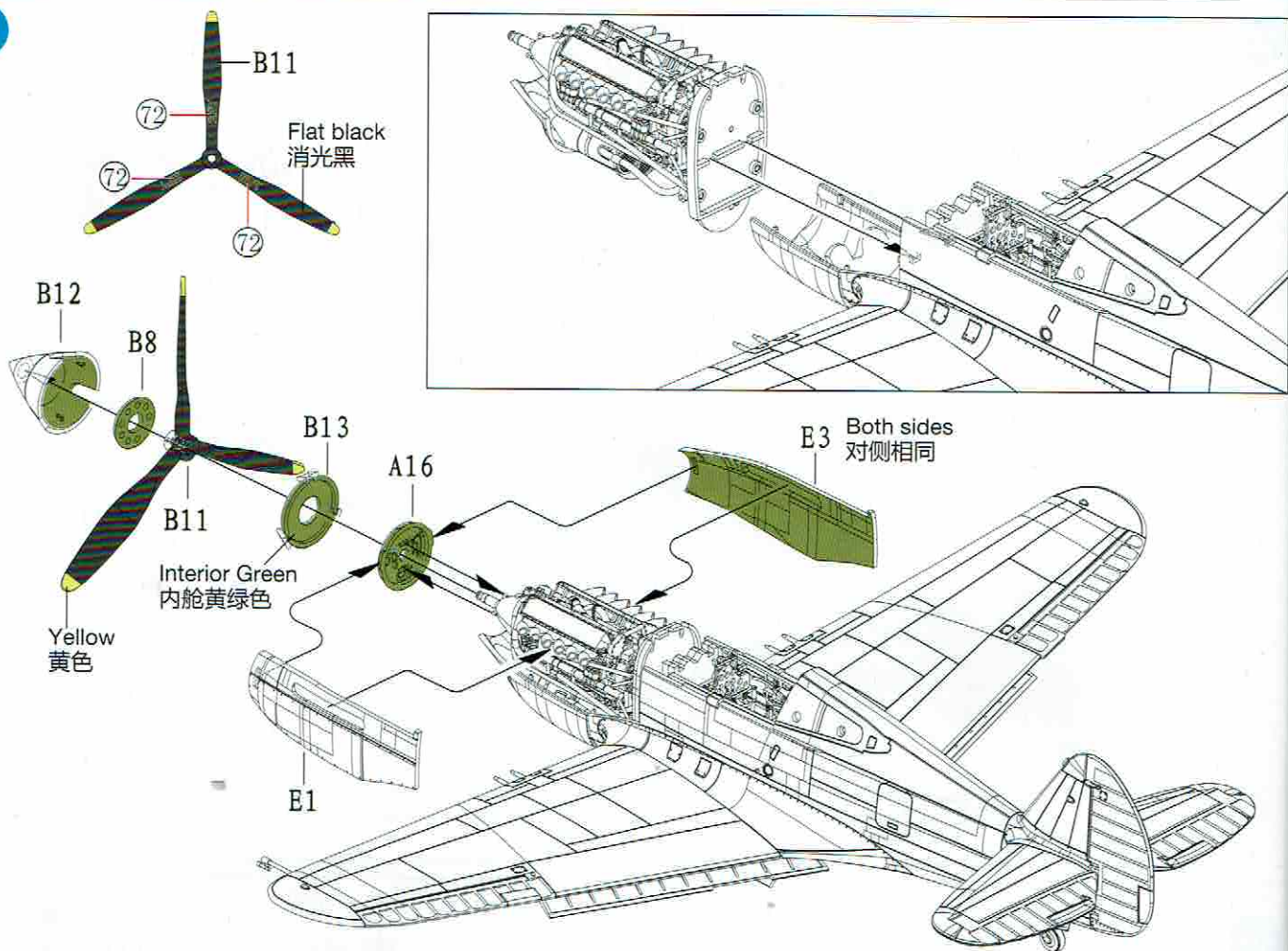

15

Option 1:
选装一：

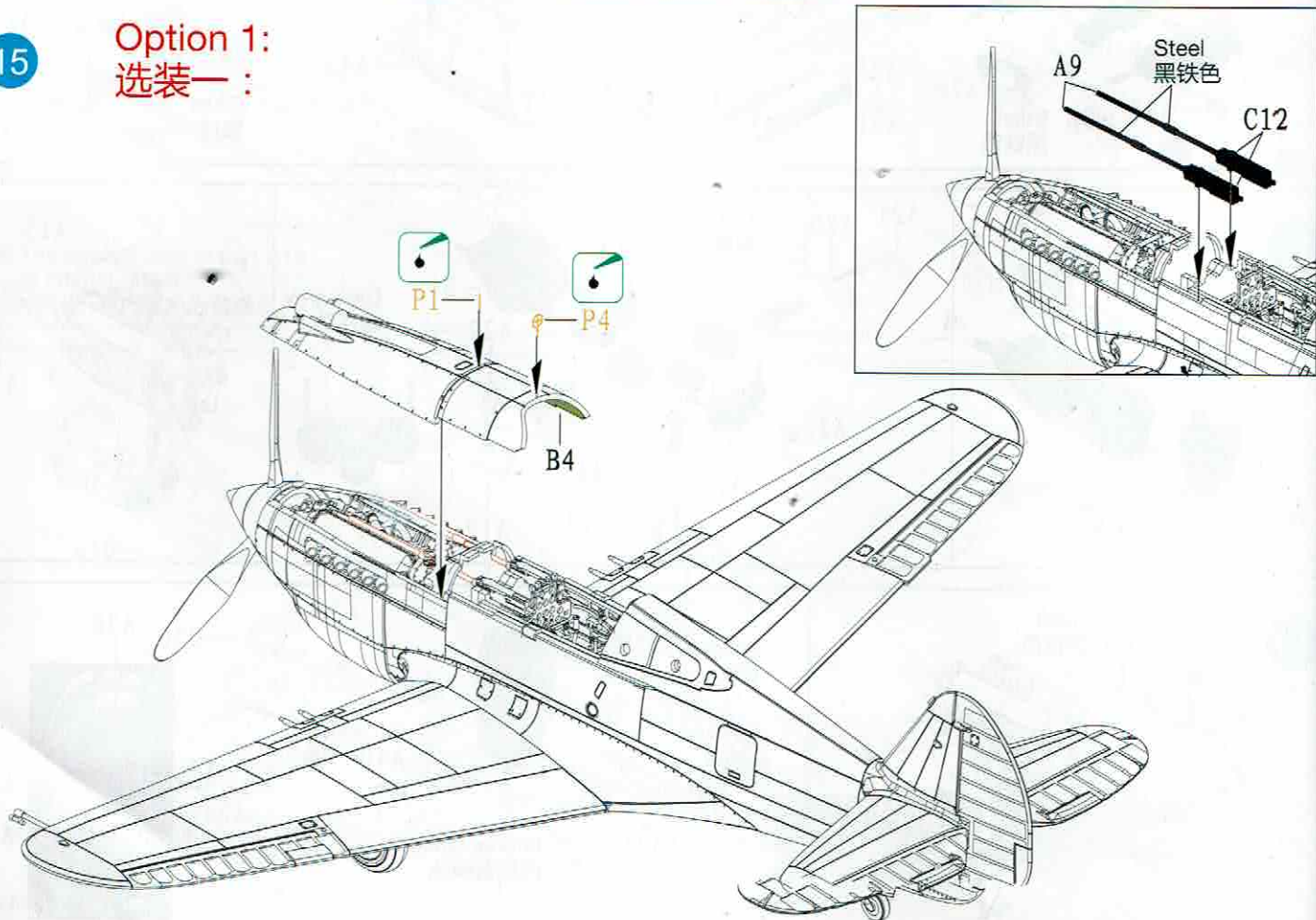

16 Option 2:
选装二：

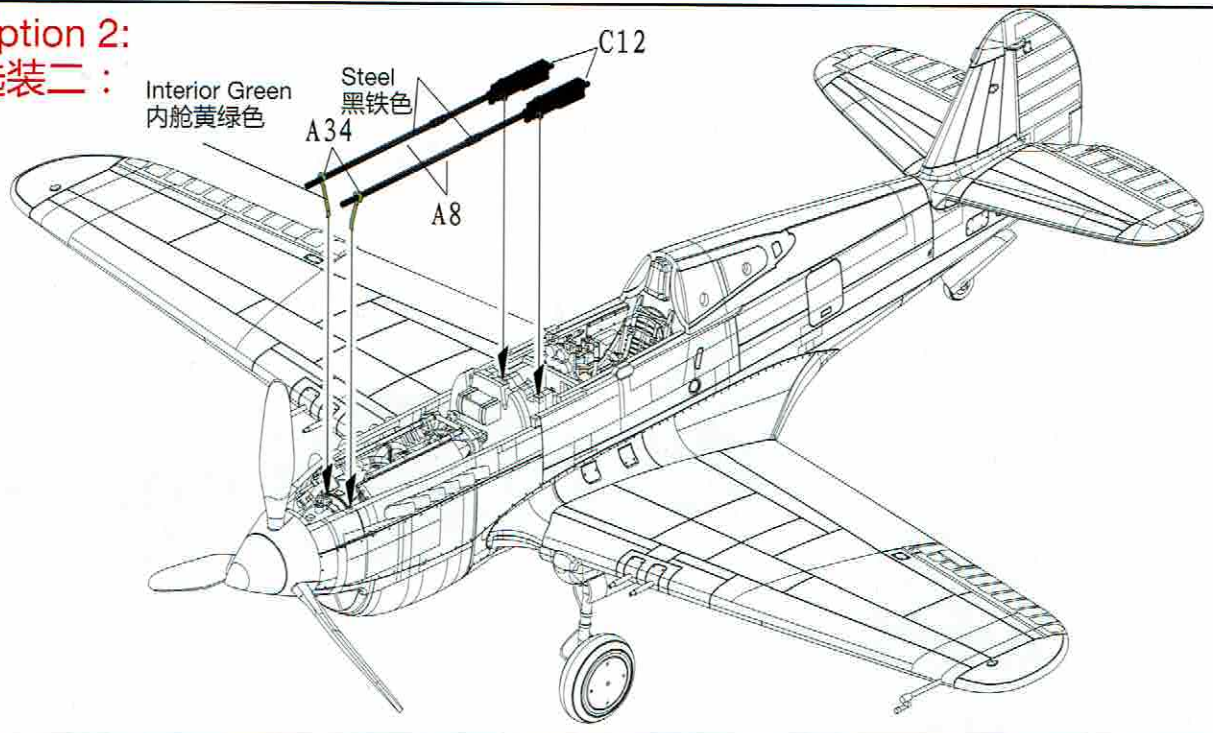

17

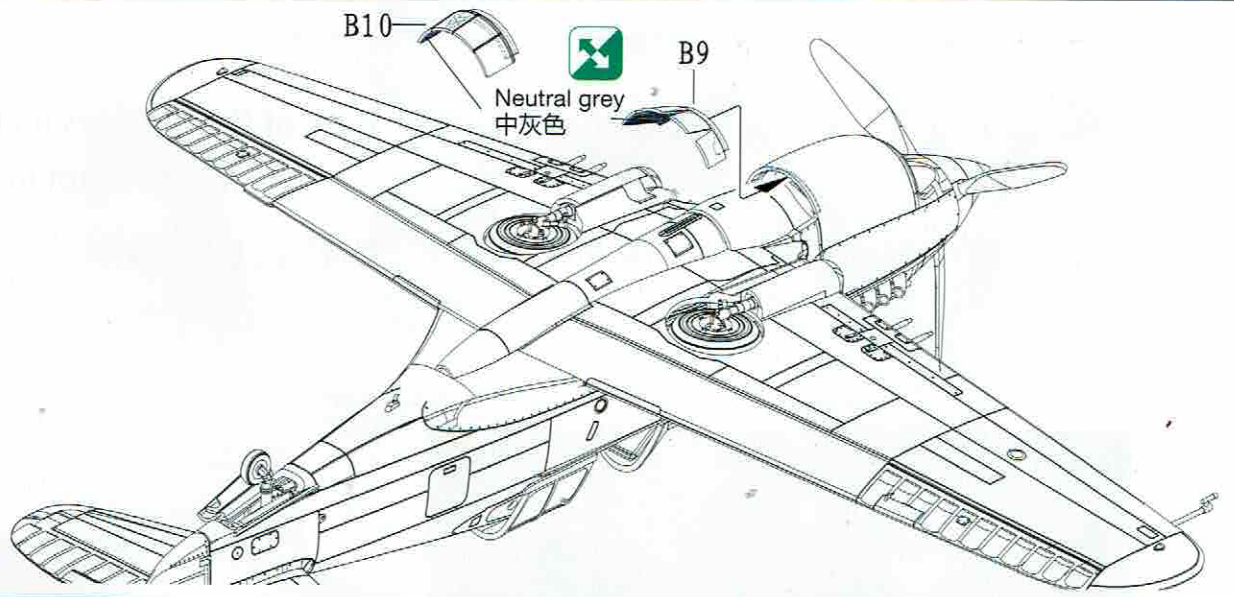

18 Hatch assembly:
座舱罩组装:

Option1: Close position
选装一：关闭状态

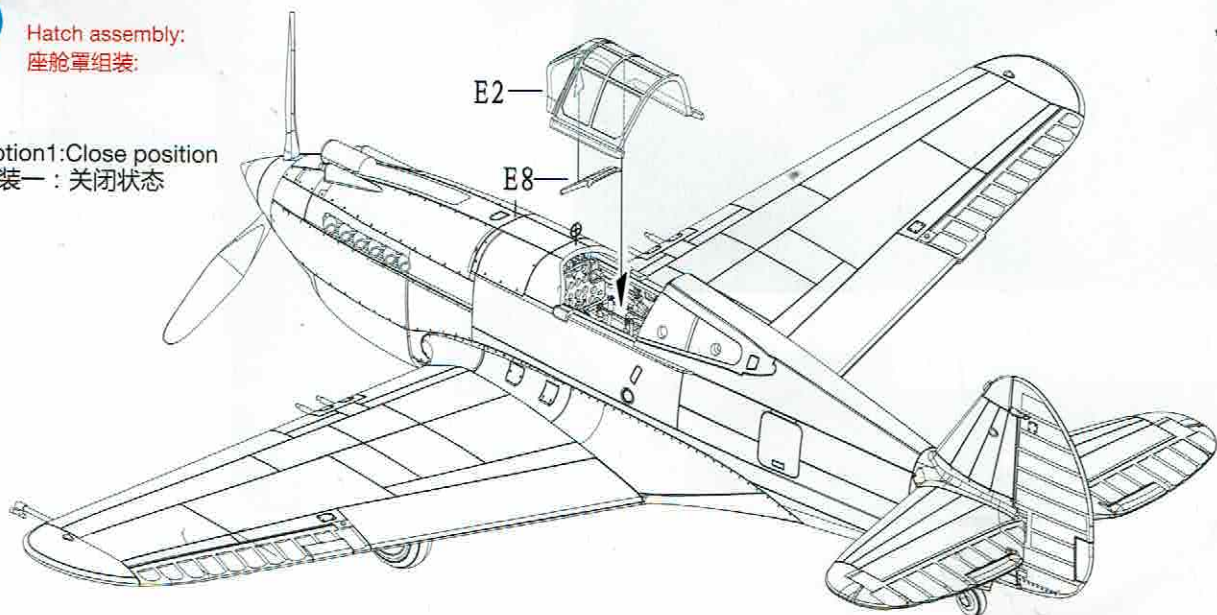

19

Hatch assembly:
座舱罩组装：

Option2: Open position
选装二：打开状态

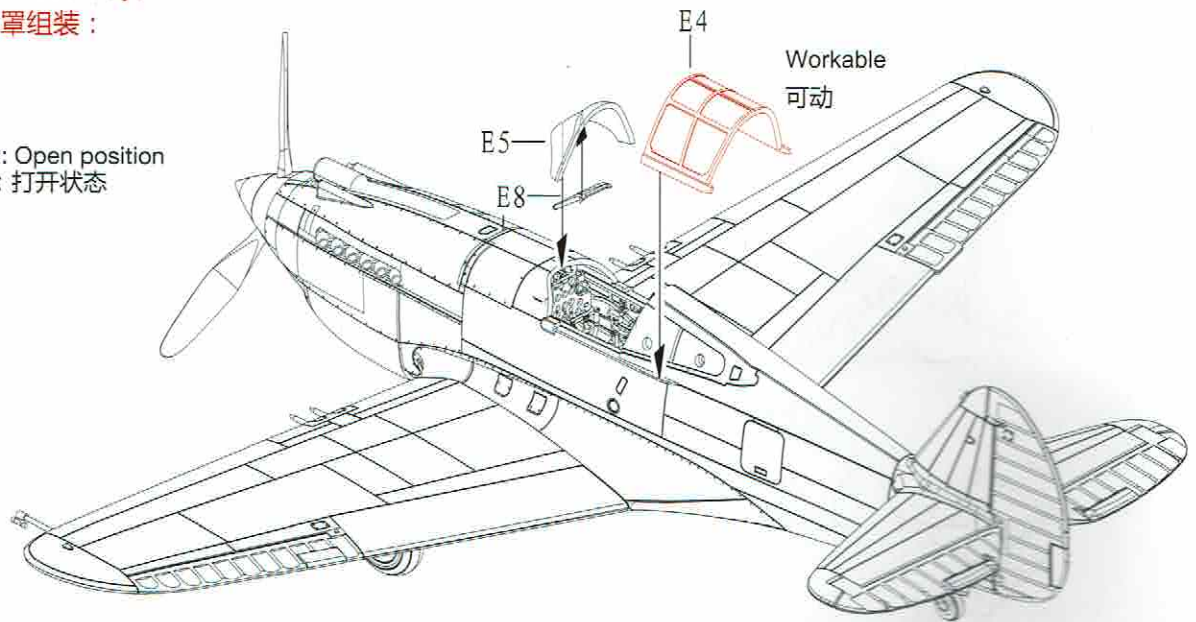

The No.80 decal is 1/48 scale "blood chit" on the back of Flying Tigers uniform.
(figure is not include)

本套件提供的第80号水贴为1/48飞虎队员制服背部之“血符”。（人物请另行购买）



80

80



Marking One : Hawk 81A-2, "3", 1PS "Adam and Eve", AVG. John R."Dick" Rossi, Burma, early1942.

霍克81A-2, 美国志愿援华航空队第1 "亚当-夏娃" 驱逐机中队, 约翰·R" 迪克 "·罗西3号机, 缅甸, 1942年初。

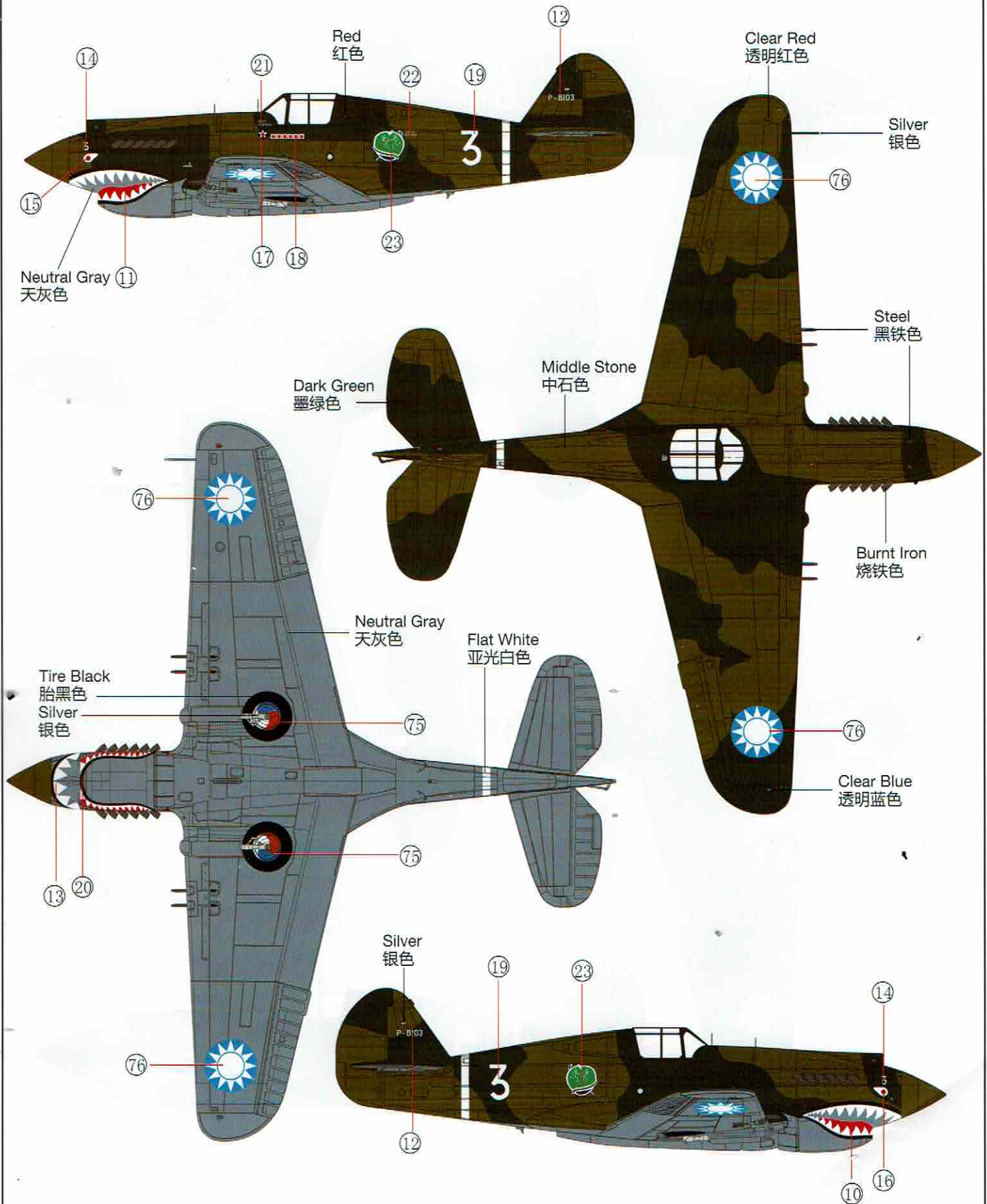

DECAL&COLOUR GUIDE 水贴及涂色指示 :

Marking Two : Hawk 81A-2, "5", 1PS "Adam and Eve", AVG.Charles Bond(6.25 victories),
China,early 1942.

霍克81A-2, 美国志愿援华航空队第1 "亚当-夏娃" 驱逐机中队, 查尔斯·邦德5号机,
中国, 1942年初。

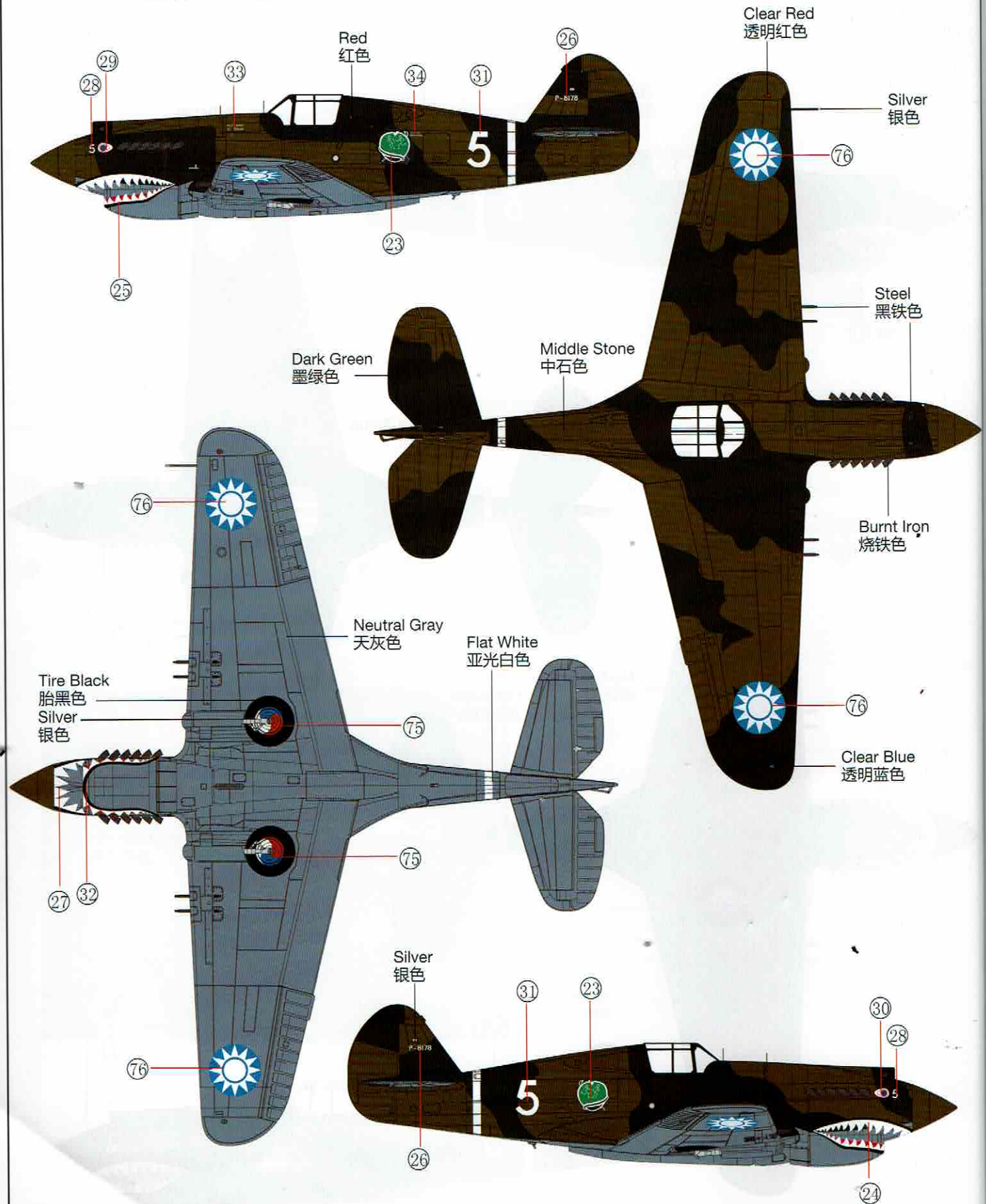

DECAL&COLOUR GUIDE 水贴及涂色指示：

Marking Three : Hawk 81A-2, "48", 2PS, "Panda Bears" Squadron leader David Lee "Tex" Hill, AVG, China, 1941-42
 霍克81A-2, 美国志愿援华航空队第2 "熊猫" 驱逐机中队队长戴维·李·德克斯·希尔, 48号机, 中国 1941-42年。

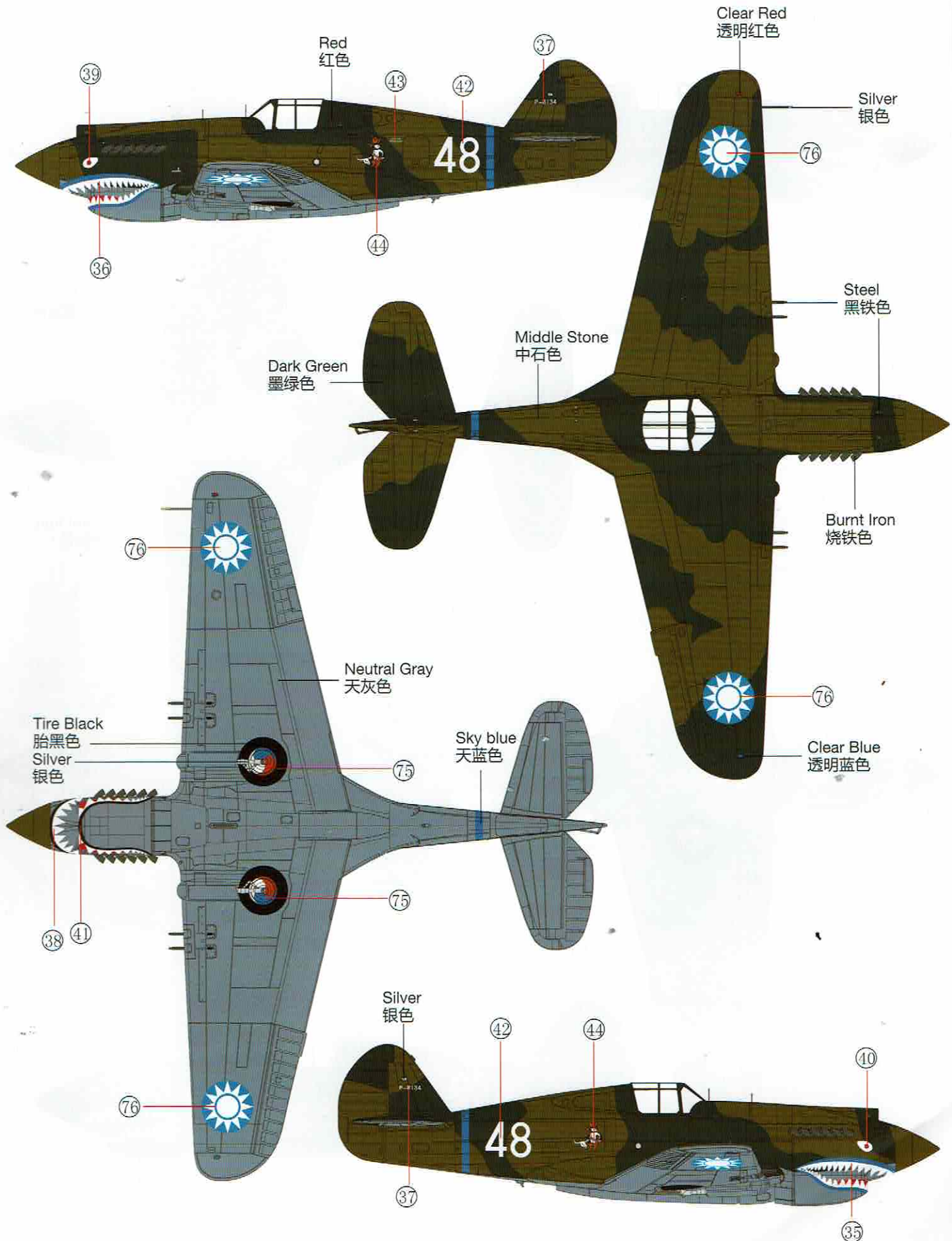

DECAL&COLOUR GUIDE 水贴及涂色指示：

Marking Four : Hawk 81A-2, '52', Erik Schilling, 2PS 'Panda Bears', AVG. Toungoo, Burma, 10. Dec. 1941.

霍克81A-2，美国志愿援华航空队第2‘熊猫’驱逐机中队 埃里克·谢林，白色52号，缅甸同固，1941年12月10日。

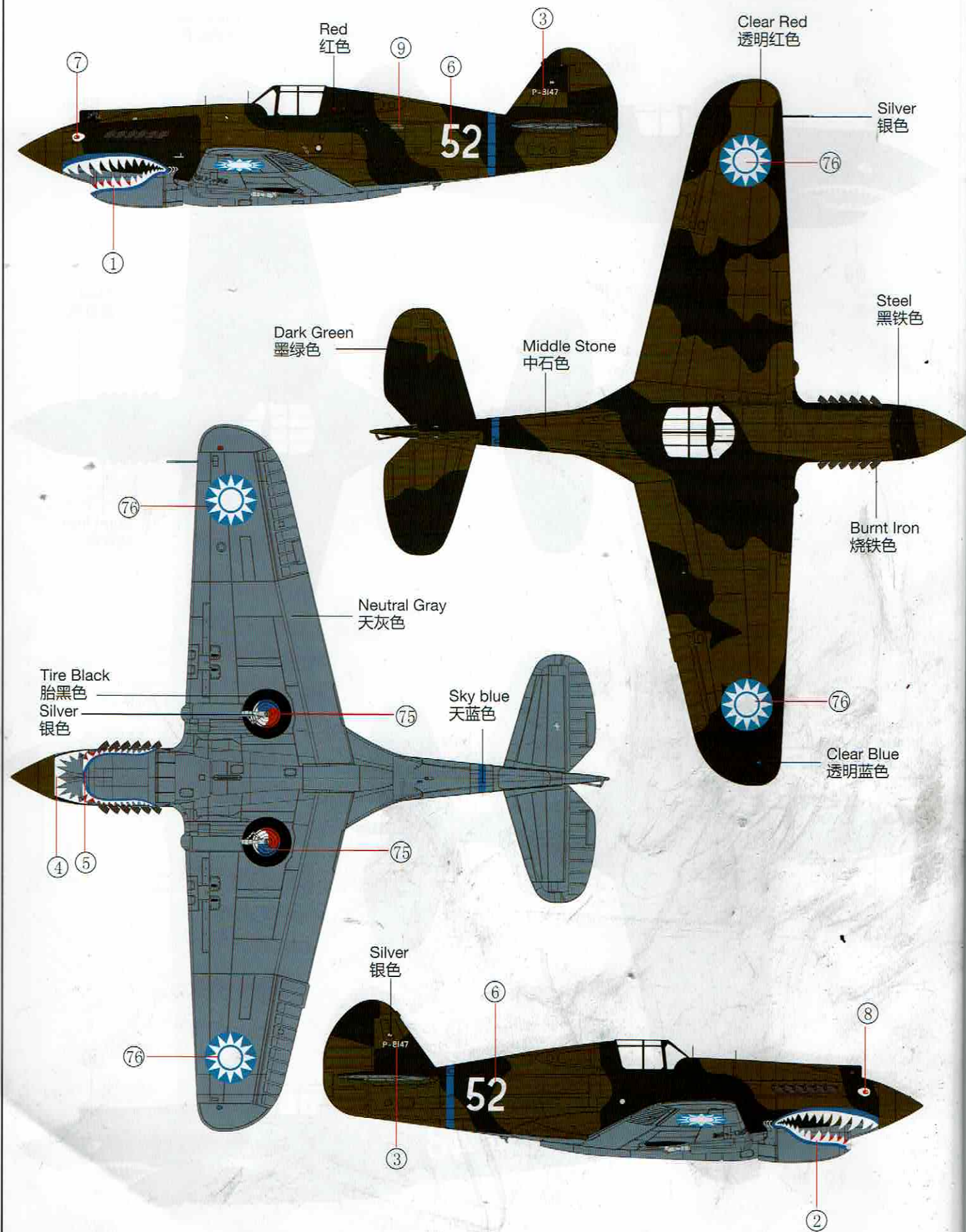

Marking Six : Hawk 81A-2, '75', 3 PS 'Hell's Angels', Bill Reed, AVG. Kunming, China, early 1942.
 霍克81A-2, 美国志愿援华航空队第3 '地狱天使' 驱逐机中队 比尔·里德 75号机,
 中国昆明, 1942年初。

