

**ENGLISH:** ASSEMBLY DRAWINGS SHOULD BE REVIEWED BEFORE PROCEEDING WITH CONSTRUCTION. A NUMBER IDENTIFIES EACH PLASTIC PART FOR YOUR CONVENIENCE. PAINT SMALL PARTS ON RUNNER BEFORE REMOVING. ALLOW PAINT TO DRY THOROUGHLY BEFORE CONTINUING ASSEMBLY OF KIT. SCRAPE CHROME OR PAINT AT AREA TO BE GLUED. WASH PLASTIC IN MILD DETERGENT SOLUTION. RINSE AND LET AIR DRY FOR BETTER PAINT AND DECAL ADHESION.

**DEUTSCH:** VOR DEM ZUSAMMENBAU DIE BAUANLEITUNG GUT DURCHLESEN. JEDES TEIL IST NUMERIERT. KLEINE TEILE ANSTREICHEN BEVOR SIE VOM RAHMEN ENTFERNT WERDEN. FARBEN GUT TROCKNEN. ERST DANN DEN ZUSAMMENBAU FORTSETZEN. CHROM UND FARBE AN DEN KLEBEFLÄCHEN ENTFERNEN. PLASTIKTEILE IN EINER MILDEN WASCHMITTELLÖSUNG REINIGEN UND AN DER LUFT TROCKNEN, DAMIT FARBE U. ABZIEHBILDER BESSER HAFTEN.

**FRANCAIS:** EXAMINER LES SCHEMAS D'ASSEMBLAGE AVANT DE COMMENCER LA CONSTRUCTION. UN NUMERO IDENTIFIE CHAQUE PIECE DE PLASTIQUE POUR PLUS DE FACILITE. PEINDRE LES PETITES PEICES SUR LE SUPPORT AVANT DE LES ENLEVER. LAISSER LA PEINTURE SECHER COMPLETEMENT AVANT DE CONTINUER L'ASSEMBLAGE DU KIT. GRATTER LE CHROME OU LA PEINTURE SUR LES SURFACE A COLLER. LAYER LE PLASTIQUE DANS UNE SOLUTION DE DETERGENT LEGERE, RINCER ET LAISSER SECHER A L'AIR POUR UNE MEILLEURE ADHERENCE DE LA PEINTURE ET DES DECALS.

**NEDERLANDS:** BESTUDER DE MONTAGE TEKENINGEN, VOORDAT U MET BOUWEN BEGINT. VOOR UW GEMAK, IDENTIFICEERT EEN NUMMER ELK PLASTIC DEEL. VERF KLEINE DEELTJES OP KIBOOM VOORDAT U ZE VERWYDERD. LAAT VERF GRONDIG DROGEN VOORDAT U DE MONTAGE VAN HET MODEL VOORTZET. SCHRAP CHROOM OF VERF VAN HET GEDEELTE DAT GELYMD WORDT. WAS PLASTIC MET EEN ZACHT ZEEP. SPOEL AF, EN LAAT IN LUCHT DROGEN, ZODAT VERF EN DECAL BETER PLAKKEN.

**SVENSKA:** IHOPSÄTTNINGSSKISSEN BÖR GRANSKAS INNAN IGANGSÄTTANDE AV BYGGANDET. ETT NUMMER IDENTIFIKERAS VARJE PLASTDEL FÖR DIN EGEN BEKVÄMLIGH ET. MALA DE SMA BITARNA DIREKT PÅ FARAN INNAN DE TAS BORT. LÅT FÄRGEN TORKA GRUNDLIGT INNAN FORTSÄTT BYGGANDE. SKRAPA AV KROMEN ELLER MALA PÅ DELARNA SOM SKALL KLISTRAS. TVÄTTA PLASTEN I MILD TVÄTTMEDLÖSNING, SKOIJ OCH LUFTTORKA FÖR BÄTTRE FASTANDE AV FÄRG OCH DEKALER.

**ESPAÑOL:** DIBUJOS DE ENSAMBLAJE DEBEN SER REPASADOS ANTES DE SEGUIR CON LA CONSTRUCCION. UN NUMERO IDENTIFICA CADA PARTE DEL PLASTICO PARA SU CONVENIENCIA. PINTA PARTES PEQUENAS DEL KIT ANTES DE QUITARLAS. DEJE SECAR BIEN LA PINTURA ANTES DE SEGUIR EL ENSAMBLAJE. RASPE EL CROMO O LA PINTURA DEL SITIO ANTES DE SER PEGADO. LAVE EL PLASTICO EN UNA SOLUCION SUAVE DETERGENTE, ENJUAGUE, Y DEJE SECAR EN EL AIRE PARA MEJOR ADHESION DE LA PINTURA Y CALCOMANIA.

**ITALIANO:** I DISEGNI DELL'ASSEMBLAGGIO DOVREBBERO ESSERE RICONTROLLATI PRIMA DI INIZIARE IL MONTAGGIO. OGNI PEZZO E IDENTIFICATO DA UN NUMERO PER VOSTRA MAGGIORE COMODITA. VERNICIARE LE PARTI PICCOLE SULLA GUIDA DE SCORRIMENTO PRIMA DE TOGLIERLE. LASCIAR ASCIUGARE LA VERNICE PRIMA DI CONTINUARE IL MONTAGGIO. RASCHIAR LA PITTURA O IL CROMO DALLE PARTI CHE DEVONO ESSERE INCOLLATE. LAVARE I PEZZI DI PLASTICA CON UN DETERGENTE NON TROPPO FORTE, SCIACQUARE E LASCIAR ASCIUGARE AFFINCHÉ VERNICE E DECALCOMANIE ADERISCANO MEGLIO.



GLUE  
KLEBEN  
COLLE  
LIJM  
KLISTER  
PEGA  
COLLA



NO GLUE REQUIRED  
NICHT KLEBEN  
LA COLLE N'EST PAS NECESSAIRE  
GEEN LIJM NODIG  
INGET KLISTER BEHOVS  
NO NECESITA PEGA  
NON C'E BISOGNO DI COLLA



DO IT THIS MANY TIMES  
ANZAHL DER ARBEITSGÄNGE  
LE FAIRE CE NOMBRE DE FOIS  
DOE HET ZOVEEL KEER  
GJOR DET SA MANGA GANGER  
FATELO TUTTE QUESTA VOLTE  
HAGALO ESTA CANTIDAD DE VECES



OPTIONAL  
WAHLWEISE  
FACULTATIF  
NAAR KEUZE  
VALFRI  
FACOLTATIVO  
OPCIONAL

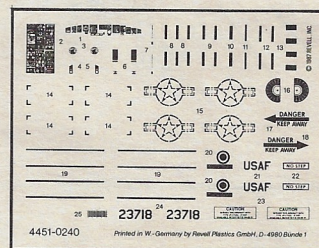

SHOWN ASSEMBLED  
ABBILDUNG ZUSAMMENGEBAUTER TEILE  
VU ASSEMBLE  
GEMONTEERD GETOOND  
VISAD IHOPSÄTTNING  
MOSTRADO ARMADO  
ILLUSTRAZIONE DEL PEZZO MONTATO



CLEAR  
KLARSICHTTEILE  
TRANSPARENT  
DOORZICHTIG  
KLART  
VIA LEBERA  
TRANSPARENTE

SOAK AND APPLY DECAL  
ABZIEHBILD IN WASSER EINWEICHEN UND ANBRINGEN  
MOUILLER ET APPLIQUER DÉCAL COMANIE  
MAAK PLAKPLAATJE DOOR EN DOOR NAT EN BEVESTIG HET  
FUKTA KLISTERMÄRKENA I VATTEN OCH SÄTT FAST  
REMOJE Y PEGUE LA CALCOMANIA  
IMMERGERE NELL'ACQUA APPLICARE CALCOMANIA

<p><b>A</b></p> <p>MATT BLACK MATT SCHWARZ 8 NOIR MAT MAT ZWART MATT ZVART NERO SMORTO</p>	<p><b>B</b></p> <p>ALUMINIUM ALUMINIUM 99 ALUMINIUM ALUMINIUM ALUMINIUM ALUMINIUM</p>	<p>60% <b>C</b> 40%</p> <p>METALLIC GREY EISENFARBIG 91 GRIS METALLIQUE IJZERKLEUR JÄRNGRÅ FERRO</p> <p>RED ROT 330 ROUGE ROOD RÖD ROSSO</p>	<p><b>D</b></p> <p>RED ROT 330 ROUGE ROOD RÖD ROSSO</p>	<p><b>E</b></p> <p>LUFTHANSA BLUE MATT MITTELGRAU 350 BLEU LUFTHANSA LUFTHANSA BLAUW LUFTHANSA BLÄ BLÜ-LUFTHANSA</p>	<p><b>F</b></p> <p>ORANGE LEUCHTORANGE 25 ORANGE ORANJE ORANGE ARANCIO</p>	<p><b>G</b></p> <p>MATT STEEL GREY MATT STAHLGRAU 47 GRIS D'ACIER MAT MAT STAALGRUIS STALGRÅ GRIGIO ACCIAIO SMORTO</p>	<p><b>H</b></p> <p>MATT LIGHT OLIVE MATT OLIV - HELL 45 OLIVE CLAIR MAT MAT LICHT OLIV MATT LJUSOLIV OLIVA CHIARO SMORTO</p>
<p><b>I</b></p> <p>OLIVE GREEN OLIVGRÖN 361 VERT OLIVE OLIVGRÖEN OLIVGRÖN VERDE OLIVA</p>	<p><b>J</b></p> <p>DARK GREEN DUNKELGRÜN 363 VERT FONCE DONKERGRÖEN MÖRKGRÖN VERDE SCURO</p>	<p><b>K</b></p> <p>DARK GREY DUNKELGRAU 378 GRIS FONCE DONKERGRUIS MÖRKANGRÅ GRIGIO SCURO</p>	<p><b>L</b></p> <p>ANTHRACITE ANTHRACIT 9 ANTHRACIET ANTRACIET ANTRACITE</p>	<p><b>M</b></p> <p>MATT MEDIUM GREY MATT MITTELGRAU 77 GRIS MOYEN MAT MAT MIDDELGRUIS MATT MALANGRÅ GRIGIO MEDIO SMORTO</p>	<p><b>N</b></p> <p>METALLIC GREY EISENFARBIG 91 GRIS METALLIQUE IJZERKLEUR JÄRNGRÅ FERRO</p>	<p><b>O</b></p> <p>MATT NATO OLIVE MATT NATO - OLIV 46 OLIVE NATO MAT MAT NATO OLIV NATO OLIVGRÖN VERDE OLIVA NATO SMORTO</p>	<p><b>P</b></p> <p>MATT WHITE MATT WEISS 5 BLANC MAT MAT WIT MATT VIT BIANCO SMORTO</p>

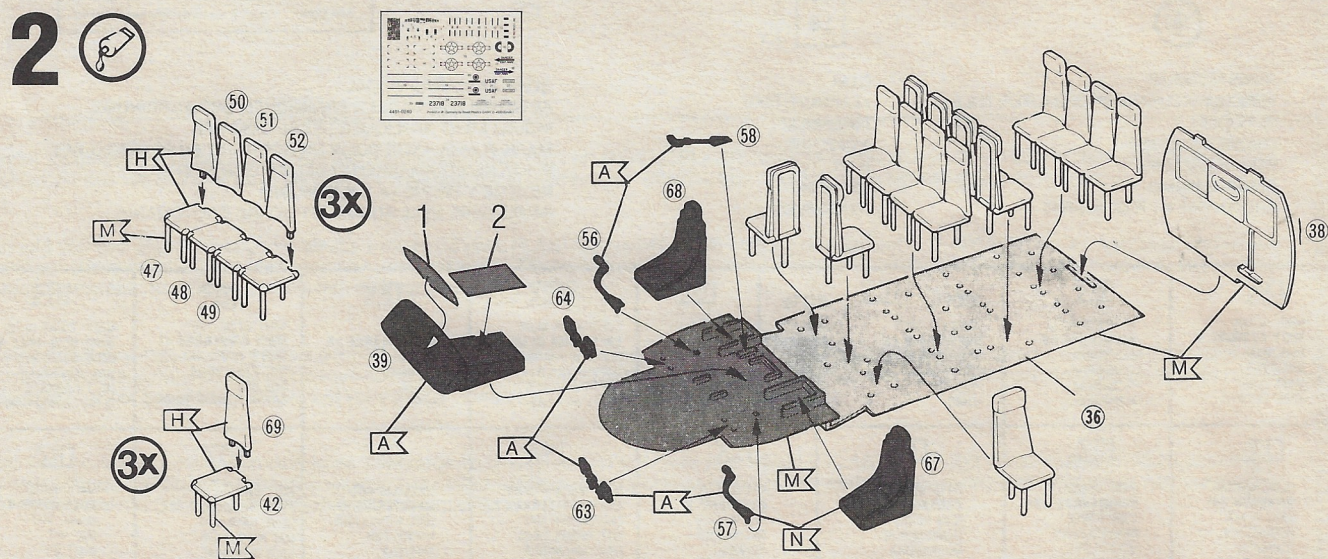
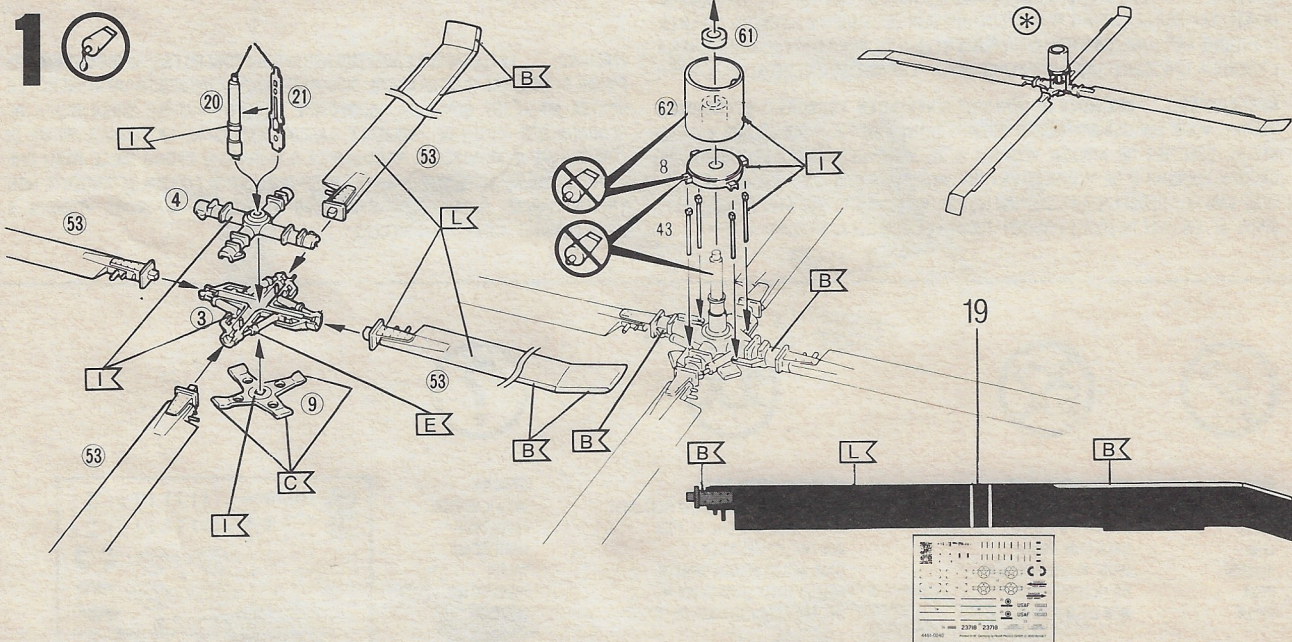
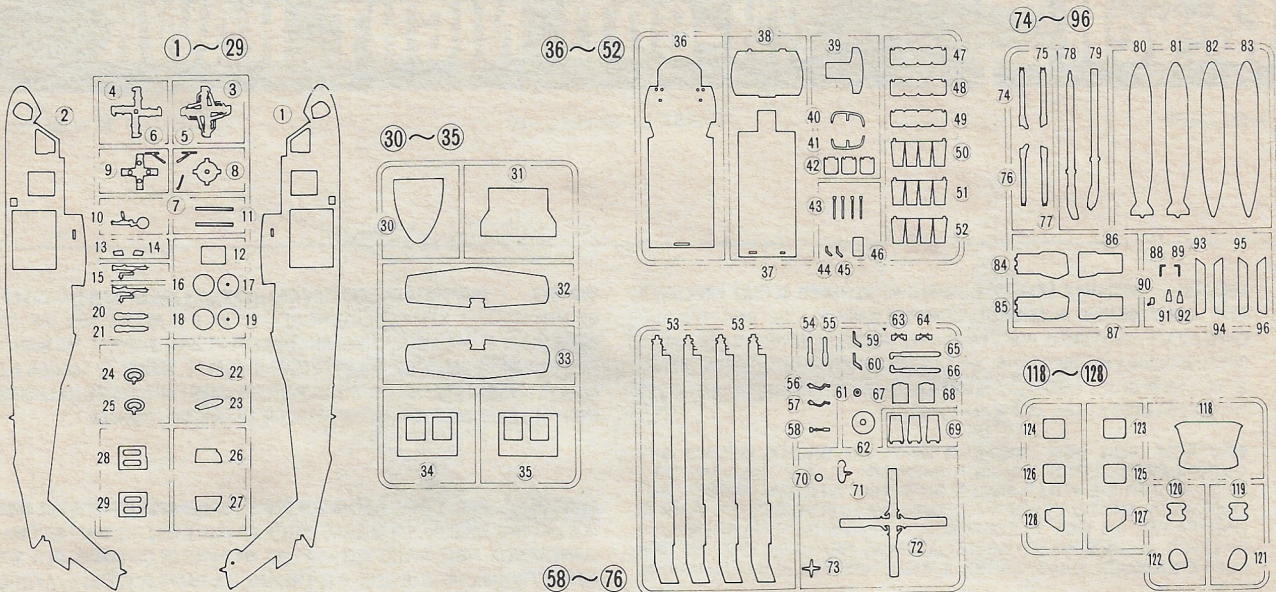

# 3

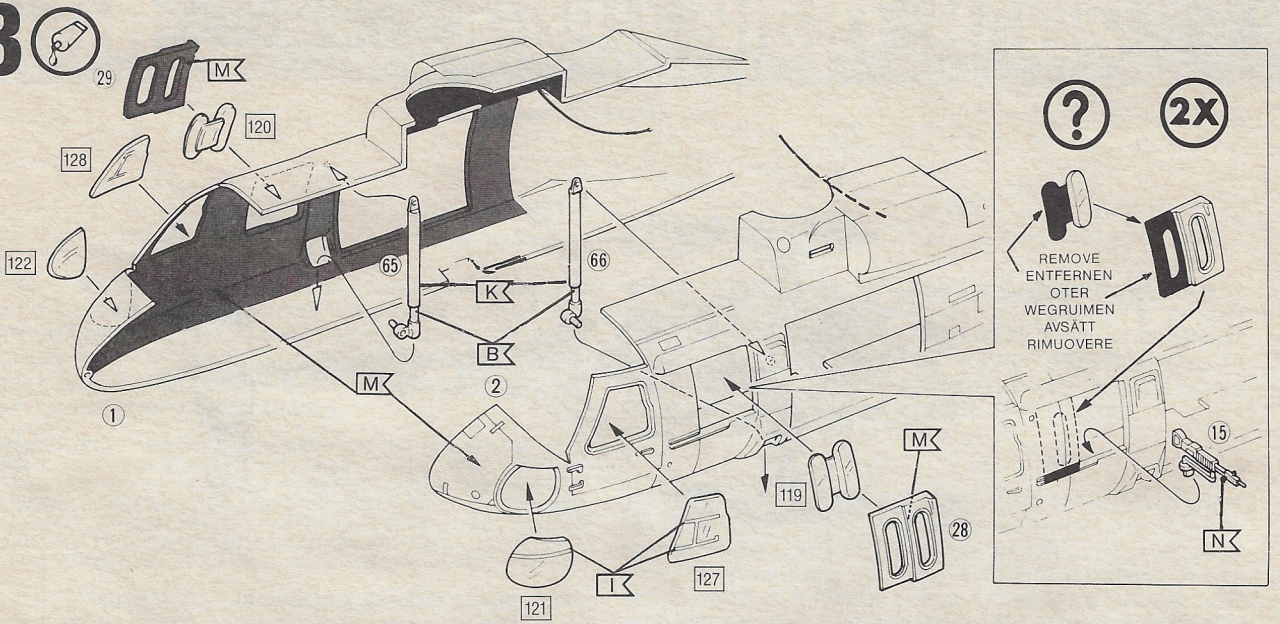

# 4

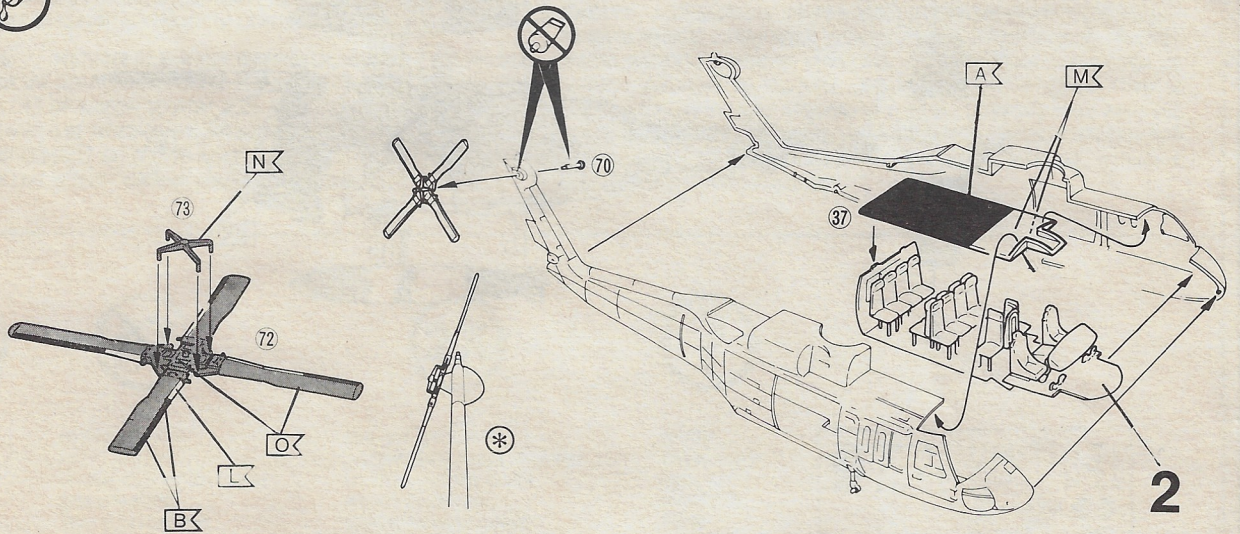

# 5

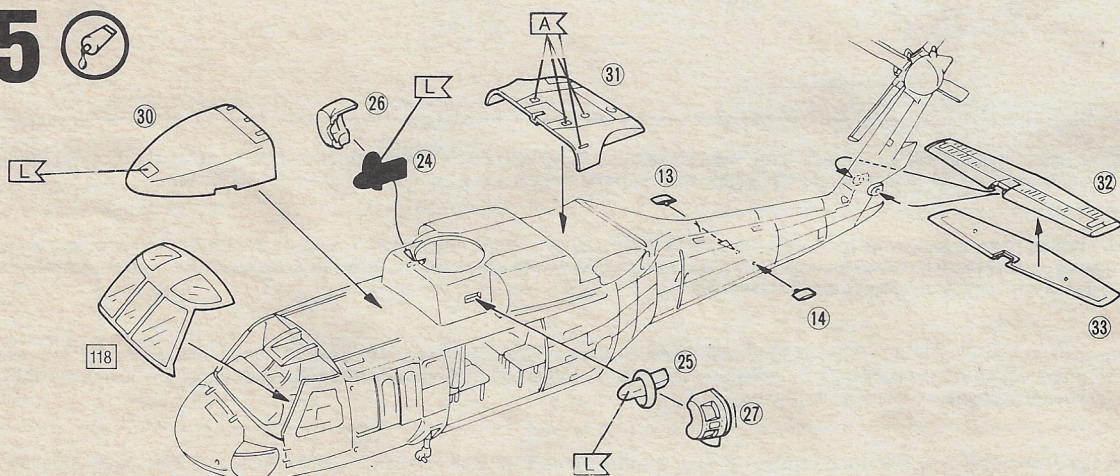

# 6

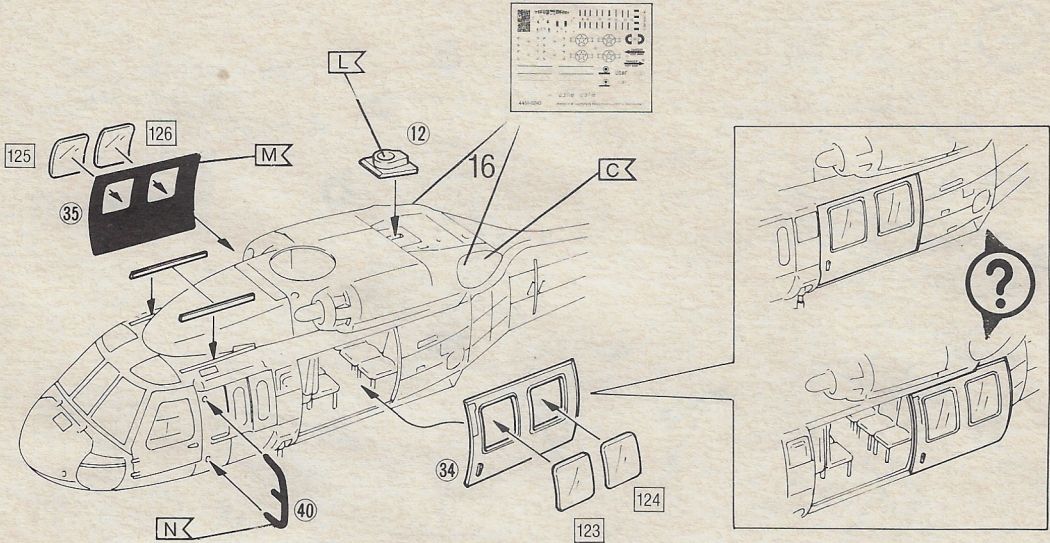

# 7

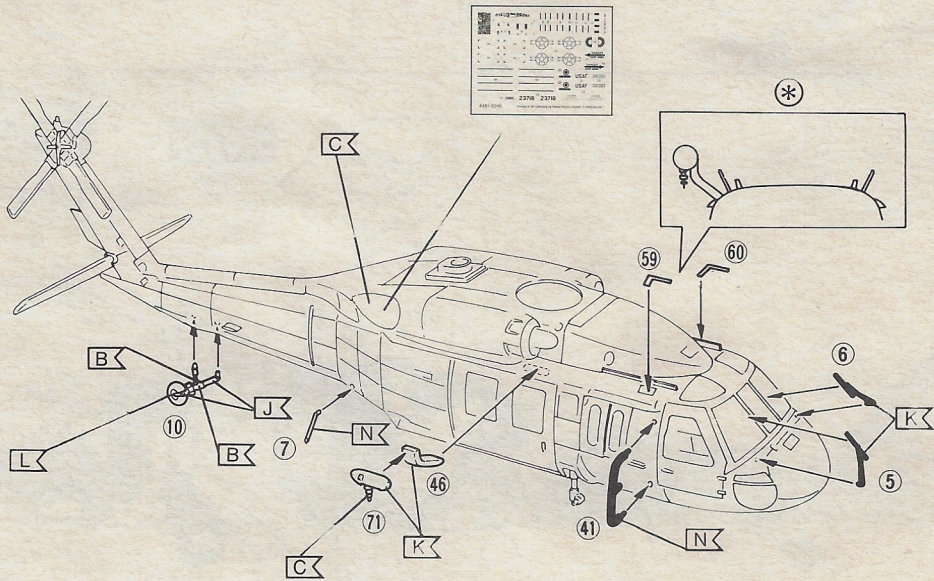

# 8

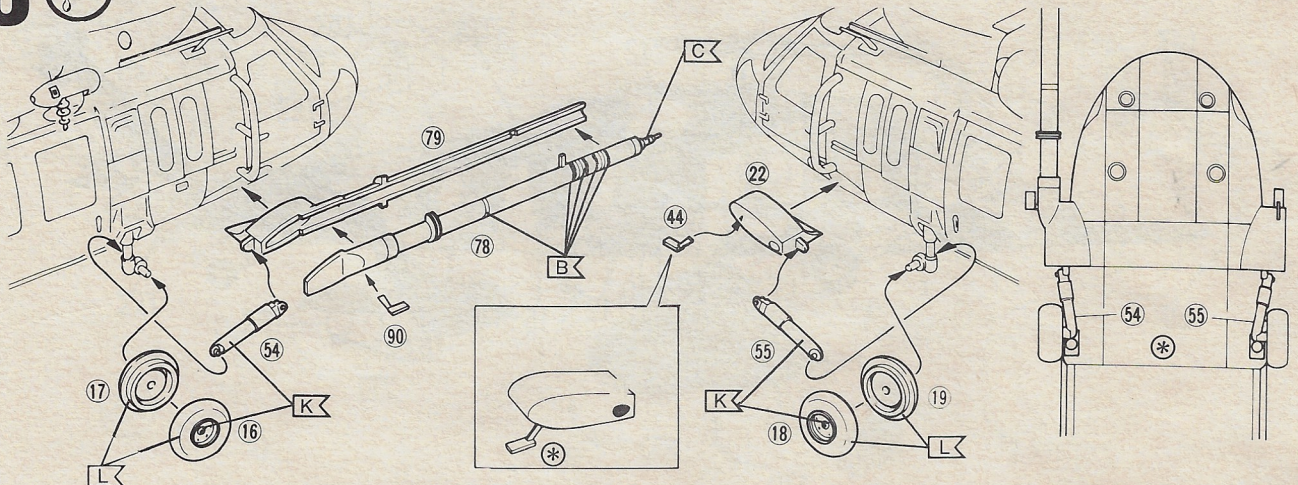

# 9

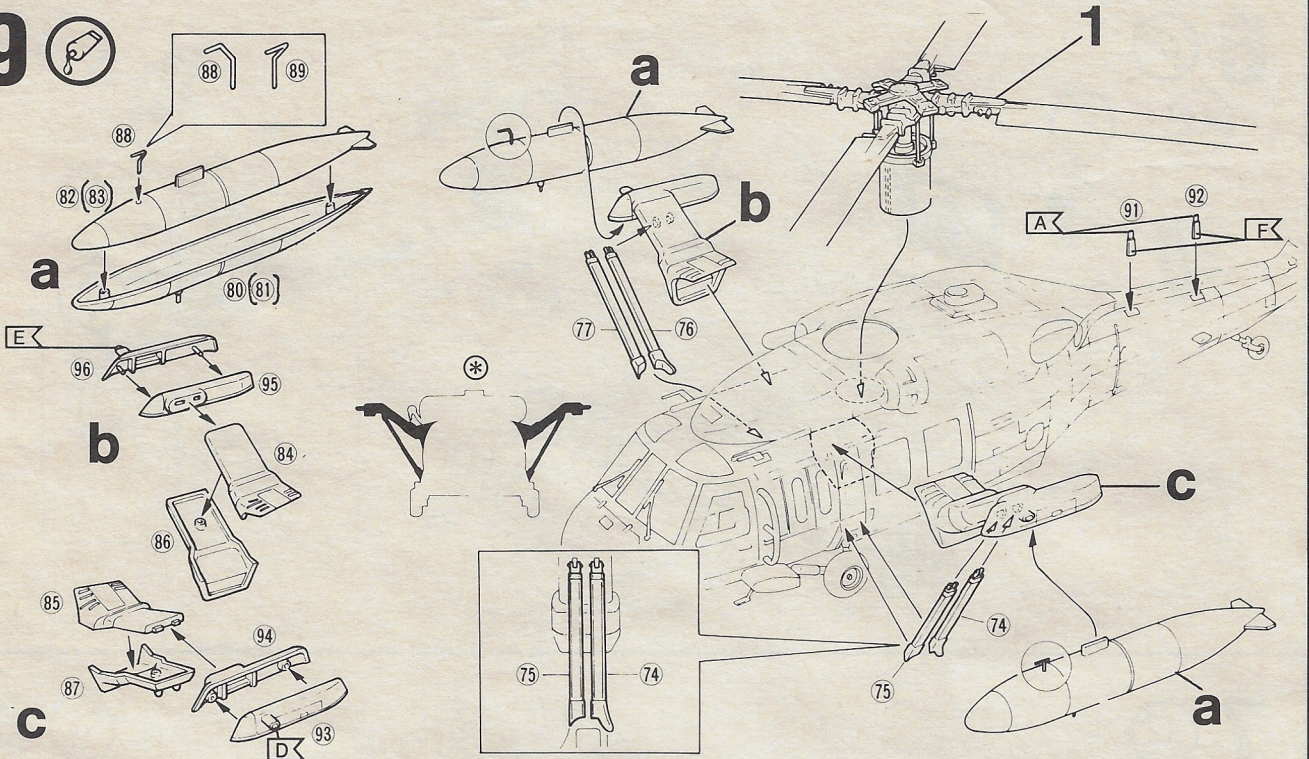

# 10

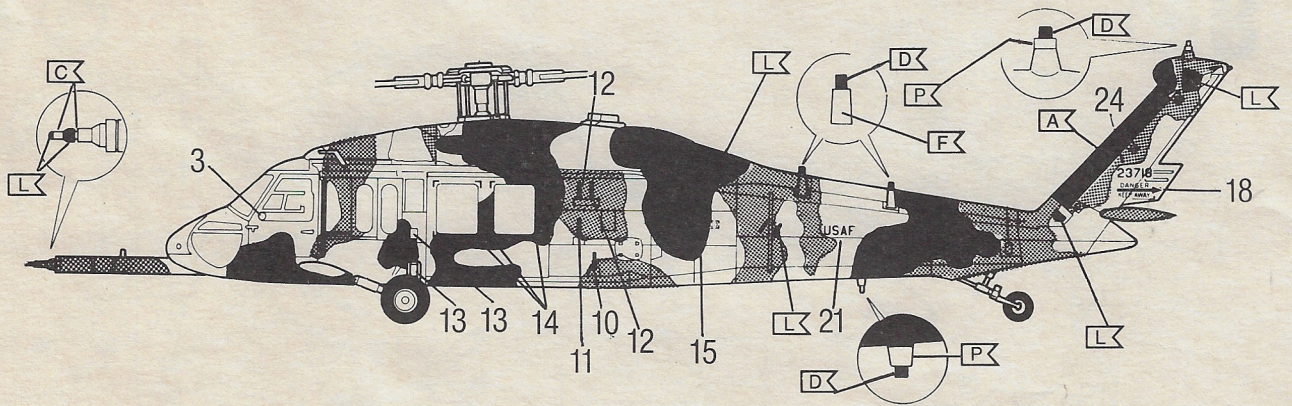
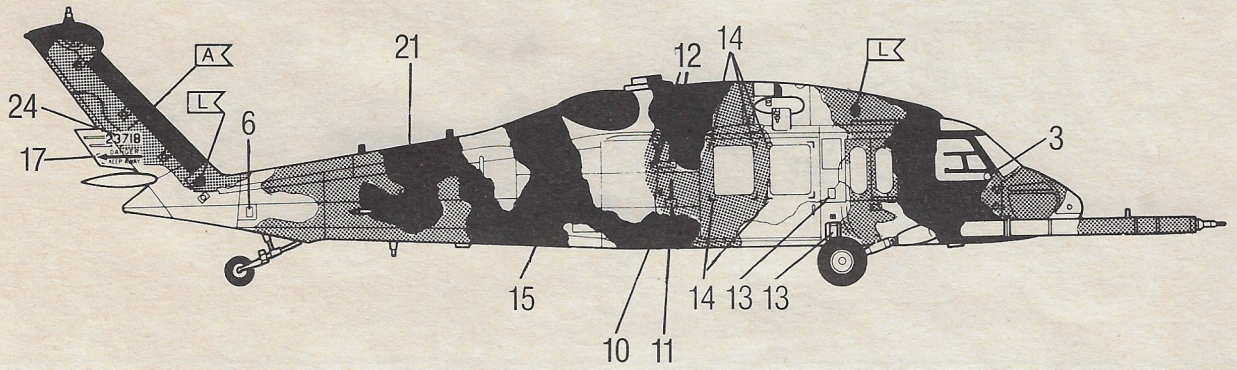
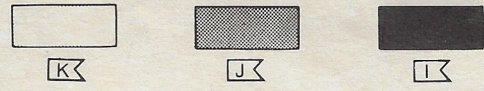
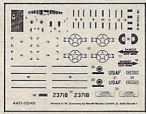

11

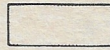
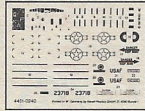

K



J



L

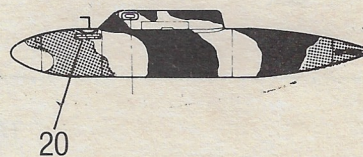
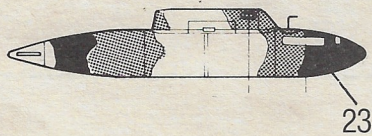
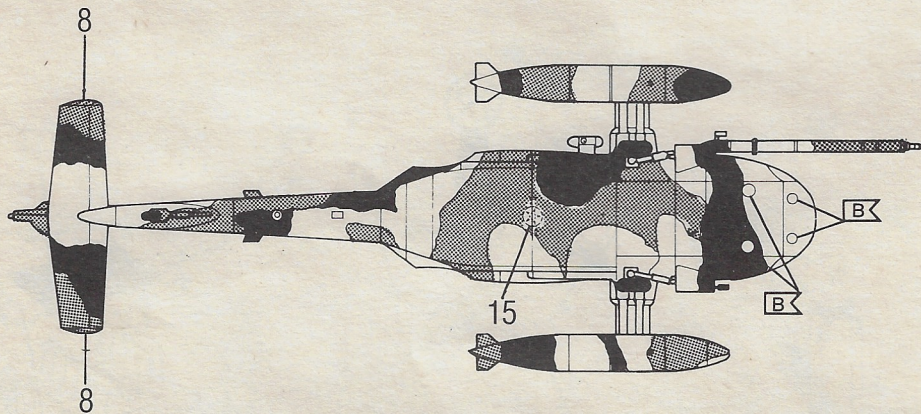
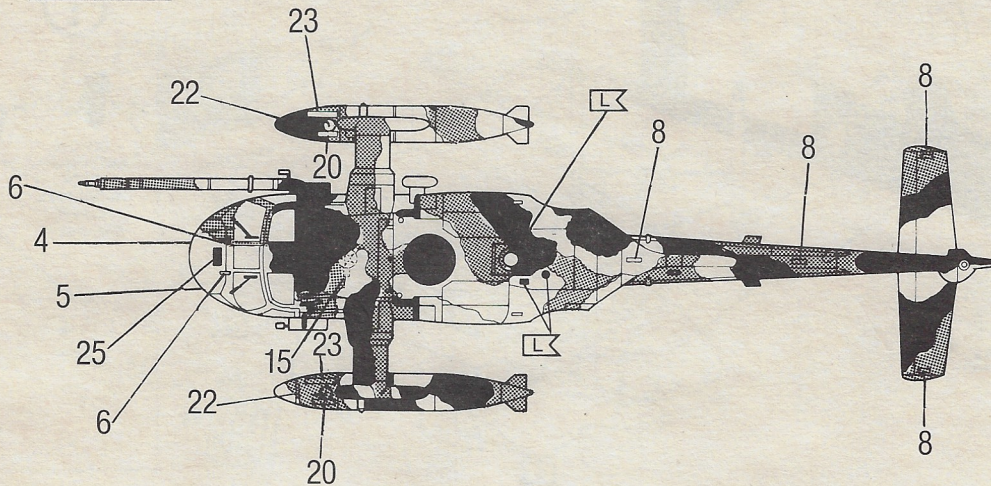

Sollte es einmal vorkommen, daß ein Teil im Bausatz fehlt, bitte an REVELL PLASTICS GMBH, Postfach 2609+2620, Abteilung X, 4980 Bünde, schreiben und die Bauanleitung, auf der das fehlende Teil angekreuzt ist, mitschicken, sonst können wir keinen Ersatz leisten.

Should you find any missing parts, please write to REVELL PLASTICS GMBH, 2609 + 2620, department X, D-4980 Bünde, W. Germany, and we will send you these as quickly as possible with our compliments. Please indicate clearly with a cross on the instruction leaflet, which piece(s) are missing. Always remember to write your name and address clearly and in full.

Pour toute pièce manquante, écrivez à REVELL PLASTICS GMBH, Postbus 2609 + 2620, département X, D-4980 Bünde, et cet élément vous sera aussitôt envoyé et ce, gratuitement. Il vous suffit dans ce cas de marquer d'une croix la pièce manquante sur la feuille d'instruction du modèle choisi. N'oubliez surtout pas d'écrire clairement votre nom et adresse.

Zou het voorkomen, dat er een deel in de bouwdoos ontbreekt, kunt U schrijven naar REVELL PLASTICS GMBH, Postbus 2609+2620, Afdeling X, D-4980 Bünde. De bouwbeschrijving waarop het ontbrekende deel aangekruist is, bijsluiten, anders kunnen wij U dit onderdeel niet vergoeden. Vergeet vooral niet Uw naam en adres duidelijk te vermelden.

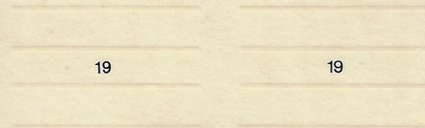
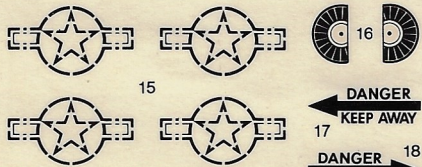
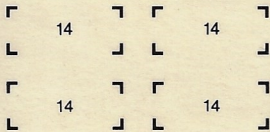
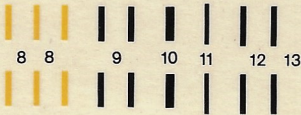

25  23718 <sup>24</sup> 23718

**CAUTION**  
SERVICE THIS AIRCRAFT WITH  
TYPE JP-4 FUEL, IF NOT  
AVAILABLE, REFER TO G. 10440-01

**CAUTION**  
SERVICE THIS AIRCRAFT WITH  
TYPE JP-4 FUEL, IF NOT  
AVAILABLE, REFER TO G. 10440-01

© 1987 REVELL, INC.

4451-0240 B

Printed in W.-Germany by Revell Plastics GmbH, D-4980 Bünde 1