

# I: FORWARD FUSELAGE ASSEMBLY

## 16 FORWARD FUSELAGE SUB-ASSEMBLY

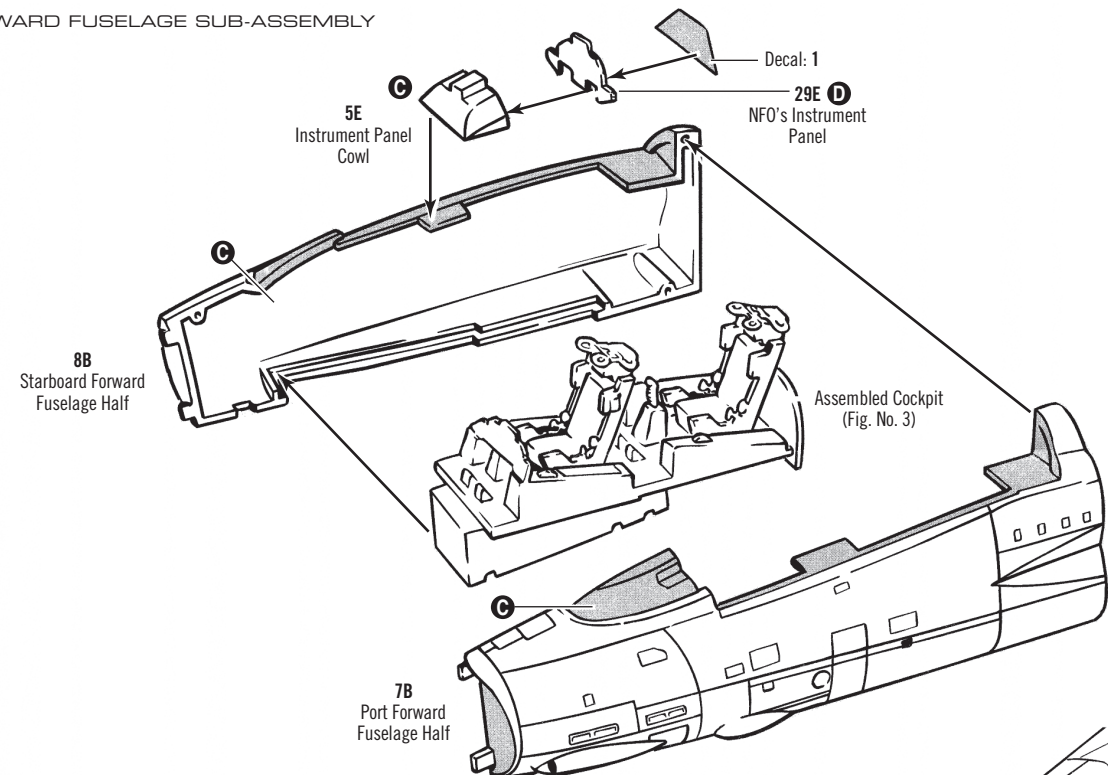

## 17 FORWARD FUSELAGE FINAL ASSEMBLY

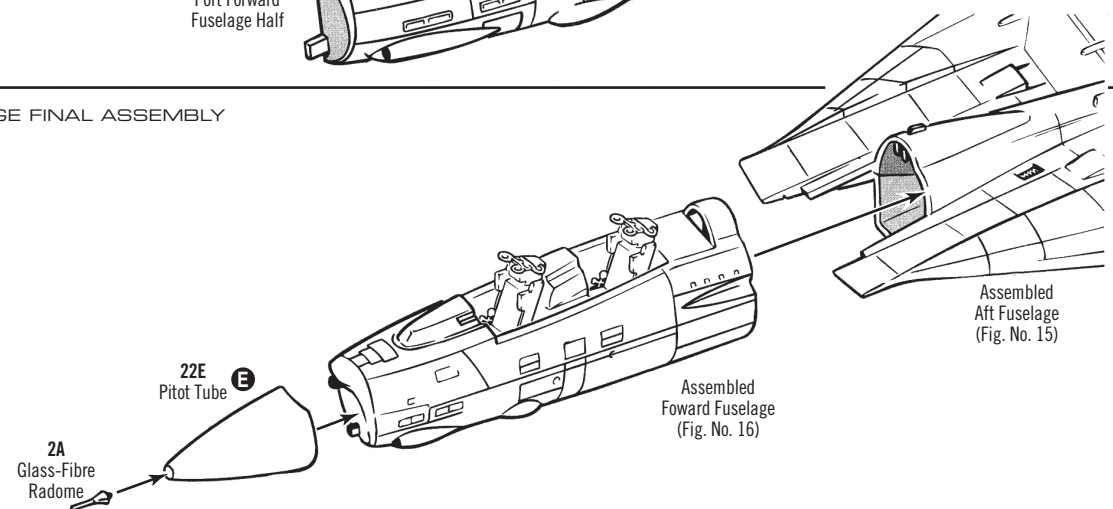

# K: FINAL ASSEMBLY

## 20 PORT MAIN LANDING GEAR ASSEMBLY

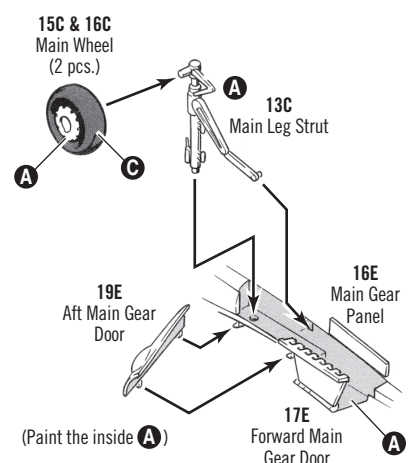

## 21 STARBOARD MAIN LANDING GEAR ASSEMBLY

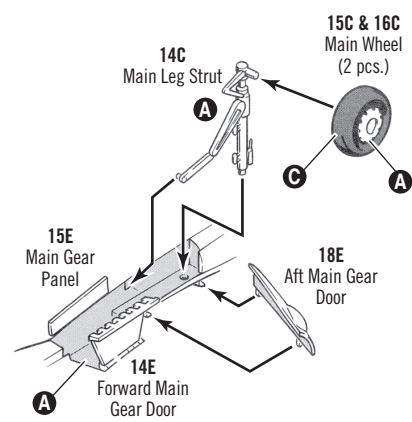

## 22 FORWARD LANDING GEAR ASSEMBLY

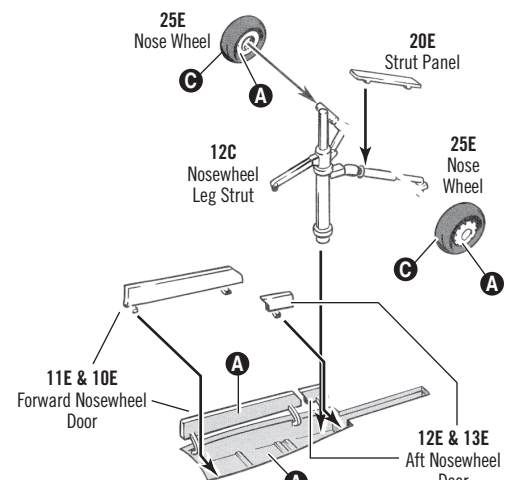

# J: CANOPY ASSEMBLY

## 18

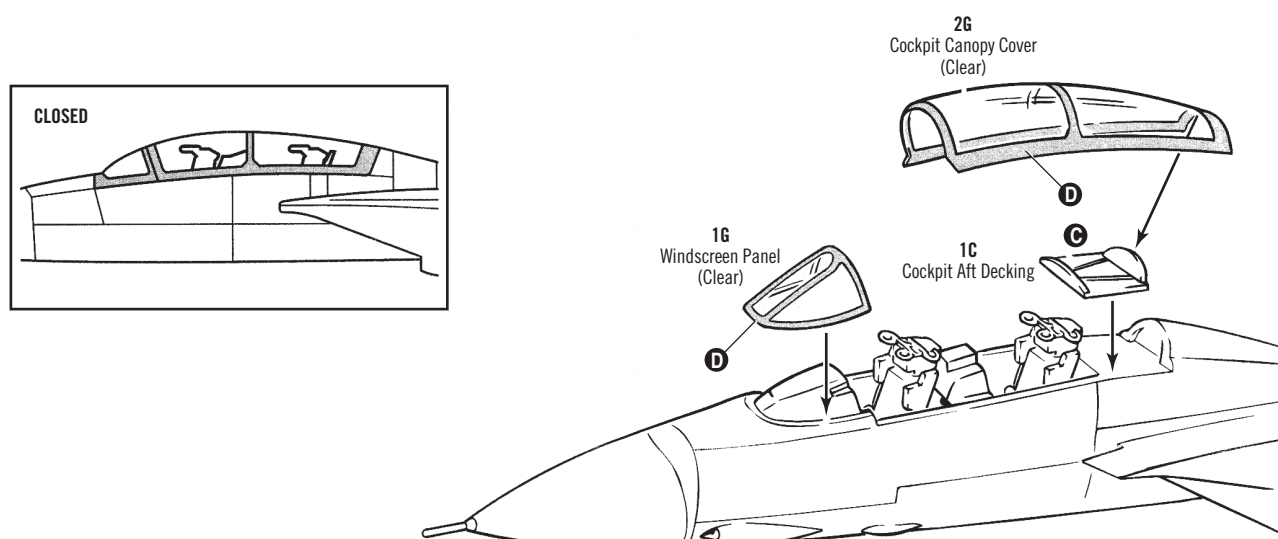

## 19

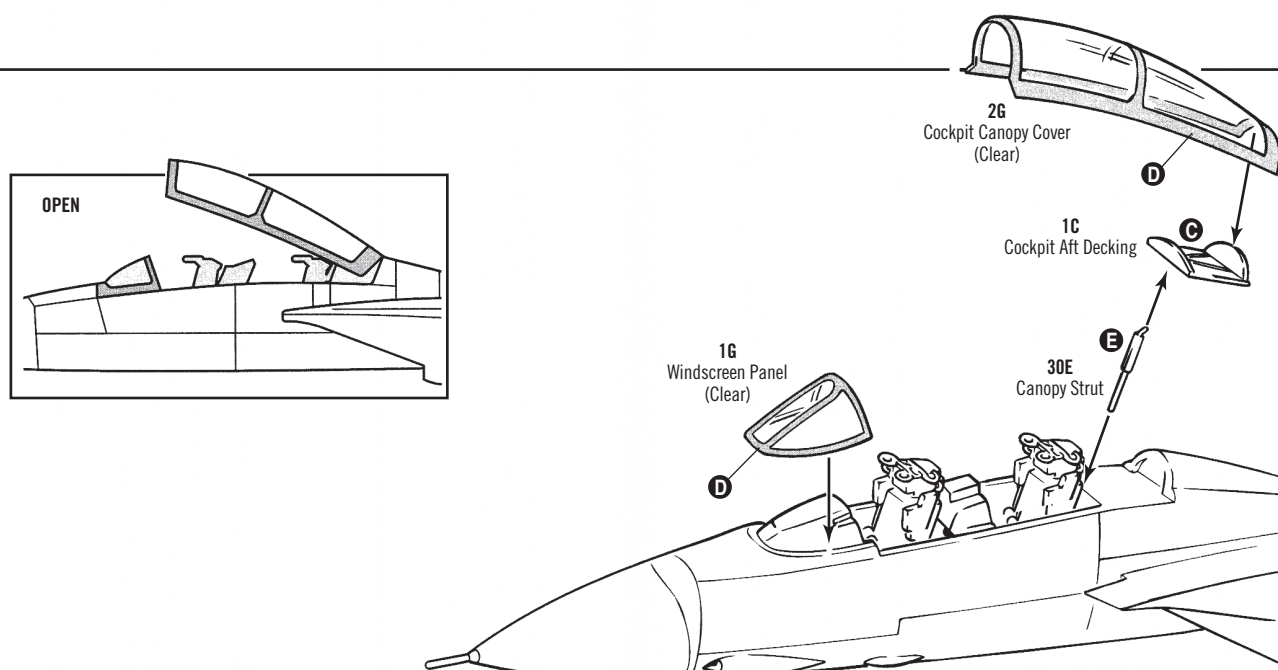

# F-14A TOMCAT™

1/72 SCALE



### WARNING

Before starting to assemble the model, carefully examine the various assembly steps indicated in the directions. A) Carefully remove the parts from the sprues using a sharp hobby knife. B) Eliminate any burrs, check the fit of each piece before cementing in place. Before assembly, paint any internal parts of the model or parts which are difficult to get at once assembly has been made. Always follow the assembly order indicated on the sheet and, in the case of alternative parts which make it possible to obtain different versions, always choose the version you prefer before assembly.

### PAINT COLORS

<b>A</b> FLAT WHITE	<b>E</b> DARK GRAY	<b>C</b> FLAT BLACK
<b>D</b> LIGHT GRAY	<b>F</b> GUN METAL	

### DECAL APPLICATION INSTRUCTIONS

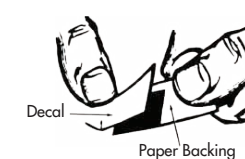

1. Cut decals apart close to image. Apply one at a time.
2. Dip decal into tepid water until paper backing loosens.
3. Moisten area of model where decal is to be applied, to aid in positioning.
4. Slide decal partly off of paper backing.
5. Place decal on model face up and slide paper backing away.
6. Thoroughly blot out excess water, air bubbles, and any excess emulsion with soft, lint-free cloth.
7. Allow time to dry before handling.

NOTE: If air bubbles or wrinkles form on an irregular or curved surface, cut decal and press into place.

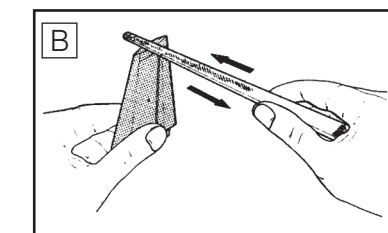
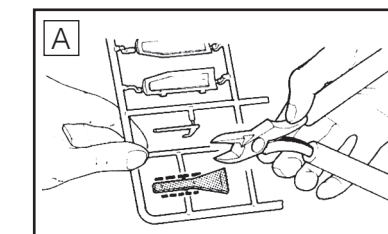

F-14 is a trademark of Northrop Grumman Systems and is used under license to Round 2, LLC. ©2013 Round 2, LLC, South Bend, IN 46628 USA. AMT & design is a trademark of Round 2, LLC. ©2013 Round 2, LLC, South Bend, IN 46628 USA. Product and packaging designed in the USA. Made in China. All rights reserved.



## A: COCKPIT/INTERIOR SUB-ASSEMBLY

### 1 MARTIN BAKER GRU7A EJECTION SEAT (2X)

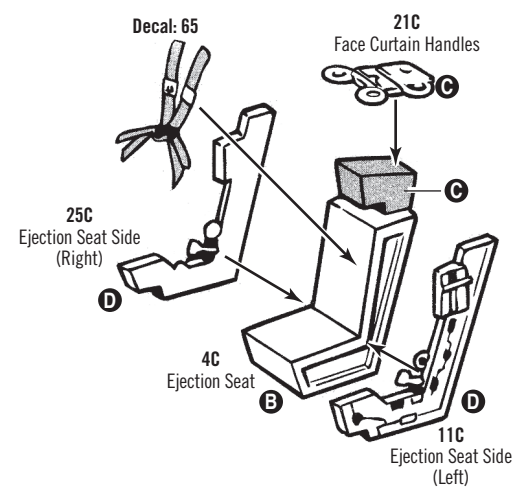

### 2 COCKPIT DETAILING

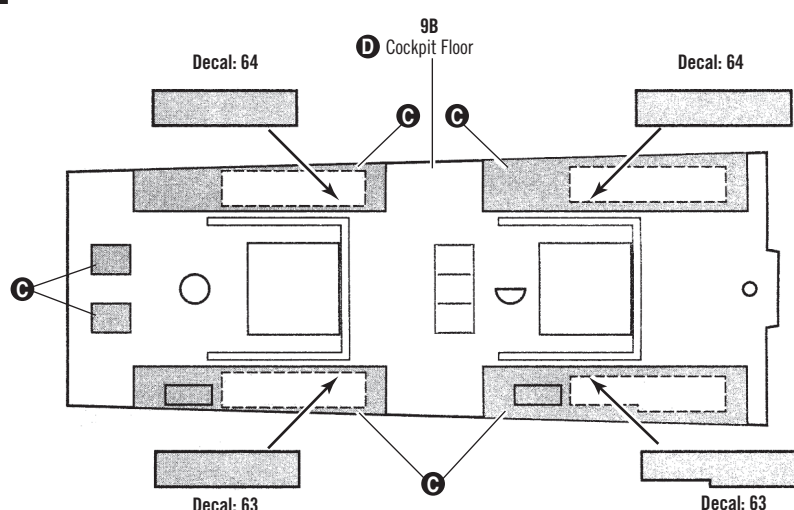

## B: COCKPIT/INTERIOR FINAL ASSEMBLY

### 3

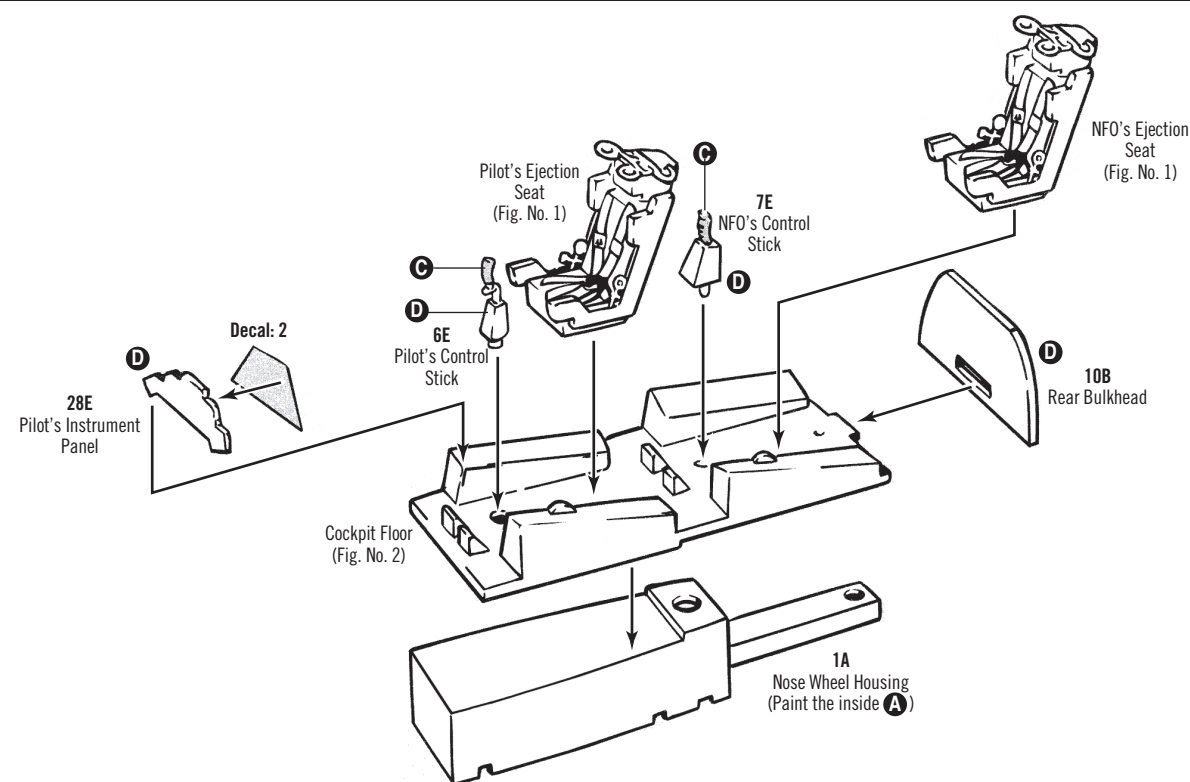

## C: VARIABLE SWING WING ASSEMBLY

### 4 PORT

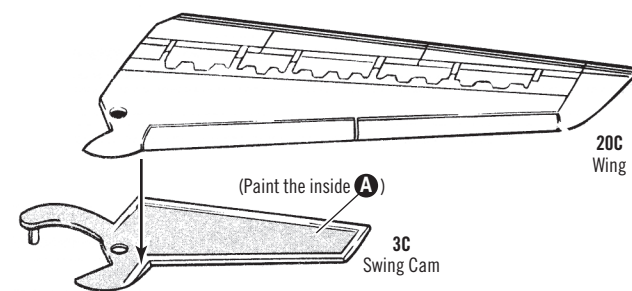

### 5 STARBOARD

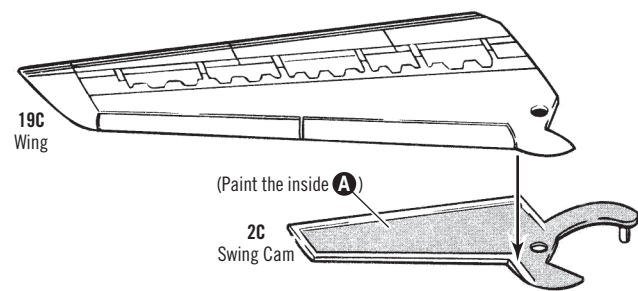

## D: AIR INTAKE ASSEMBLY

### 6 PORT

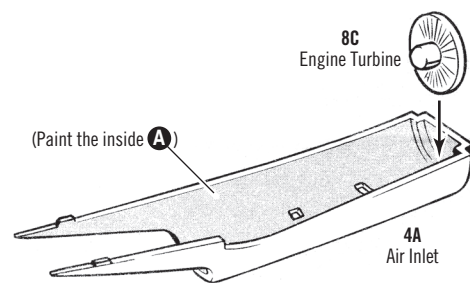

### 7 STARBOARD

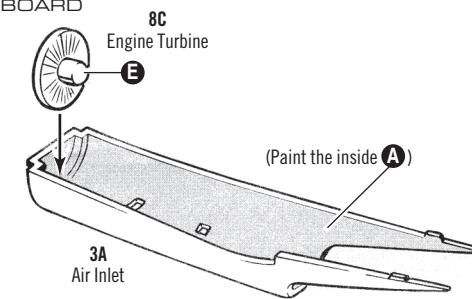

## E: EXHAUST ASSEMBLY

### 8 EXHAUST OPTION A (OPEN) (2X)

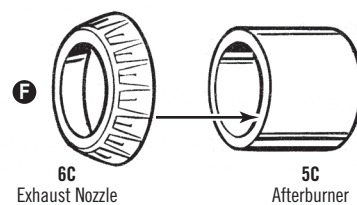

### 9 EXHAUST OPTION B (CLOSED) (2X)

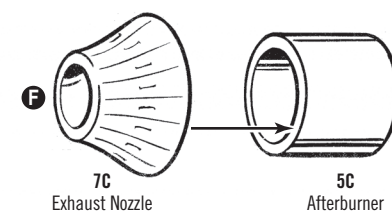

## G: WEAPONS PYLON ASSEMBLY

### 11 PORT

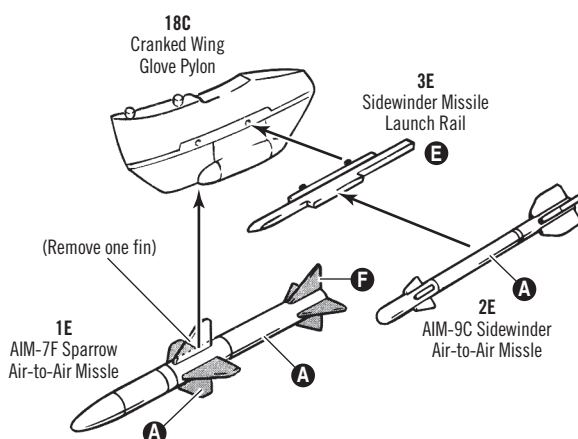

### 12 STARBOARD

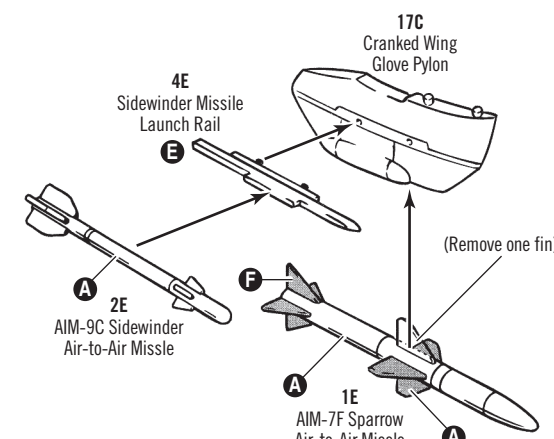

## H: AFT FUSELAGE ASSEMBLY

### 13 AFT FUSELAGE SUB-ASSEMBLY "A"

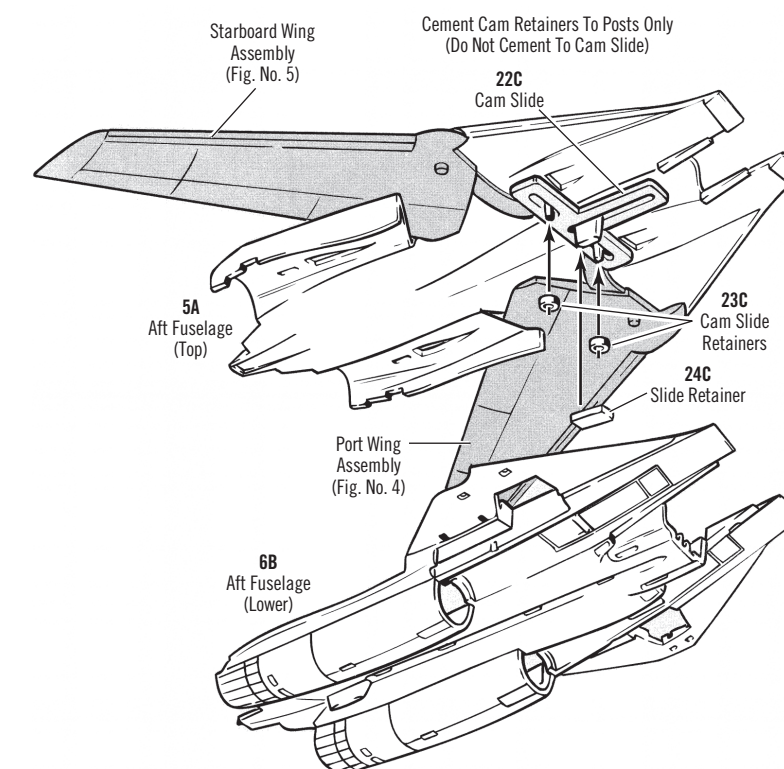

### 14 AFT FUSELAGE SUB-ASSEMBLY "B"

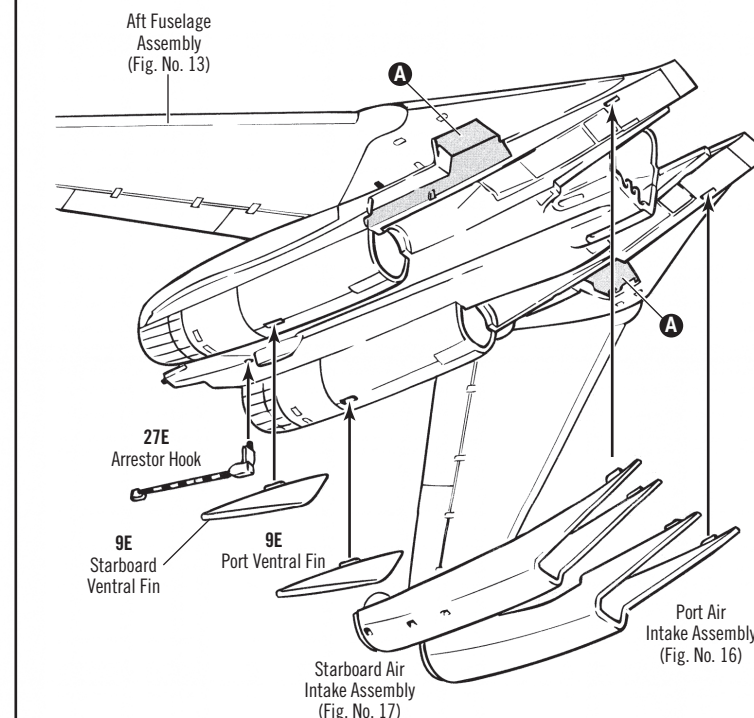

### 15 FINAL AFT FUSELAGE SUB-ASSEMBLY

