

G.W.H.[®]

1/48
SCALE
L4829



A-10C 雷電二式 近距离支援攻击机
THUNDERBOLT II
CLOSE AIR SUPPORT ATTACK AIRCRAFT

注意事項 CAUTION 組み立てのご注意

- (1) 勿于近火处使用胶水或油漆，并打开窗户保持空气流通。
- (2) 涂料的号码请参考本栏以下的说明。本品本身不包括胶水和涂料。
- (3) 自板件中取出部件时，应用模型专用剪，并用介刀或小锉除去多余胶料。
- (4) 各图形的含义可参考本栏以下说明。

- (1) When you use glue or paint, do not use near a open flame, and use in a well-ventilated room.
- (2) See below for the color list. Glue and paint are not included in the kit.
- (3) When you take parts off the runner frame, use the modeling scissors and trim excess plastic with a cutter or a file.
- (4) See below for the meaning of symbols.

- (1) 接着剂や塗料は火の近くで使わないで下さい、使用の際は換気をよくして下さい。
- (2) 塗料指定のは下記のとおりです、接着剂や塗料が入っていないので別に求めて下さい。
- (3) 部品のランナーから切り離す時は模型用ハサミ等を使い、余分な部分はカッターやヤスリ等で仕上げして下さい。
- (4) 組立図のサインマークは下の説明を御覧下さい。

图形含义 CAUTION マーク

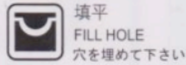

填平
FILL HOLE
穴を埋めて下さい

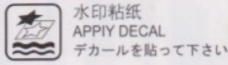

水印粘紙
APPLY DECAL
デカールを貼って下さい

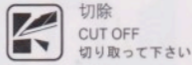

切除
CUT OFF
切り取って下さい

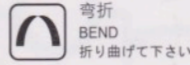

弯折
BEND
折り曲げて下さい

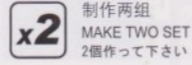

制作两组
MAKE TWO SET
2個作って下さい

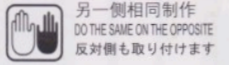

另一側相同制作
DO THE SAME ON THE OPPOSITE
反対側も取り付けます

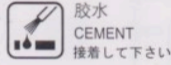

胶水
CEMENT
接着して下さい

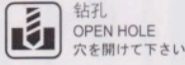

钻孔
OPEN HOLE
穴を開けて下さい

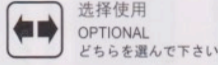

选择使用
OPTIONAL
どちらを選んで下さい

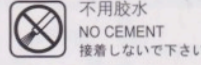

不用胶水
NO CEMENT
接着しないで下さい

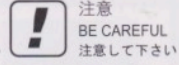

注意
BE CAREFUL
注意して下さい

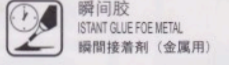

瞬间胶
INSTANT GLUE FOR METAL
瞬間接着剂 (金属用)

所使用工具 RECOMMENDED TOOLS 専用工具

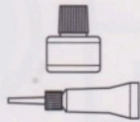

塑胶件用模型胶水
Cement
プラスチック用接着剂

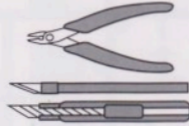

模型用剪钳
Side cutters
模型用ニッパー

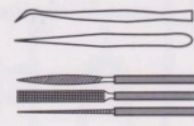

模型用镊子
Tweezers
ピンセット

模型用瞬间胶水
Instant Cement
瞬間接着剂

模型用刻刀
Modeling knife
模型用ナイフ

模型用锉刀
Diamond file
模型用ヤスリ

水贴纸使用说明 DECAL APPLICATION スライドマークの貼り方

- (1) 用模型剪刀或刻刀切下所需的图案部分。
- (2) 将水贴纸浸泡在温水中10秒左右取出放置于戏水的干布上。
- (3) 手拿着水贴纸基的一角，用模型镊子小心夹住浮起的水贴图案移至模型表面准确位置。
- (4) 用手指适当沾水均匀涂于水贴图案表面，使其延展移动至精确位置。
- (5) 用柔软吸水的干布将水贴图案中的气泡向一边挤出，使水贴在模型表面保持平整。

- (1) Cut off decal from sheet.
- (2) Dip the decal in tepid water for about 10 sec. and place on a clean cloth.
- (3) Hold the backing sheet edge and slide decal onto the model.
- (4) Move decal into position by wetting decal with finger.
- (5) Press decal down gently with a soft cloth until excess water and air bubbles are gone.

- (1) 貼りたいマークをハサミで切り抜きます。
- (2) マークをぬるま湯に10秒ほど浸してからタオル等の布の上に置きます。
- (3) 台紙のはしを手で持ち、貼るところにマークをスライドさせてモデルに移して下さい。
- (4) 指に少し水を付けてマークを濡らしてながら、正しい位置にずらしします。
- (5) 柔らかな布でマークの内側の気泡を押し出しながら、押しつけるようにして水分をとります。

蚀刻片使用说明 PHOTO-ETCHED PARTS エッチングパーツ

- (1) 使用蚀刻片专用剪刀或模型专用刻刀将蚀刻片零件切割下待用。
 - (2) 切割下的零件上有蚀刻片的残留连接点部分，使用模型专用锉刀细心打模干净。
 - (3) 蚀刻片部分在涂装之前必须使用专用的模型金属底漆打底。
- 注意事项：蚀刻片很薄外延较为尖锐，有刮伤手的可能，在使用之时请务必小心。

- (1) Cut off photo-etched parts using a modeling knife.
 - (2) Carefully remove any excess using a file.
 - (3) Apply metal primer prior to painting.
- Attention, please: Extra care should be taken to avoid personal injury when handling photo-etched parts.

- (1) 切り離す時はカッターナイフを使用してパーツを切り離します。
 - (2) 切り出した時、部品に出張った部品が残っている場合は、ヤスリなどで丁寧に削り落とします。
 - (3) 塗装が必要なパーツは下地にメタルプライマーを吹き付けてから塗装します。
- ご注意：エッチングパーツは大変薄く、手などを切り恐れがあります。取扱いは十分注意して下さい。

涂装色表 PAINT REQUIRED カラー番号リスト

■ C|000 GSI CREOS Mr.COLOR

| | | | | | |
|--------|------|------------------|-------|------------|---------------|
| C 2 | 亮光黑 | Black | C 55 | 卡其色 | Khaki color |
| C 4 | 亮光黄 | Yellow | C 137 | 轮胎黑 | Tire black |
| C 8 | 亮光银 | Silver | C 214 | 黑铁 | Black iron |
| C 10 | 亮光铜 | Coppery | C 304 | 橄榄褐FS34087 | Brown FS34087 |
| C 28 | 黑铁色 | Black iron | C 305 | 灰FS36118 | Grey FS36118 |
| C 33 | 消光黑 | Extinction black | C 306 | 灰FS36270 | Grey FS36270 |
| C 47 | 透明红 | Clear red | C 307 | 灰FS36320 | Grey FS36320 |
| C 50 | 透明蓝 | Clear blue | C 308 | 灰FS36375 | Grey FS36375 |
| C 316 | 白 | White | | | |
| C 317 | 灰 | Grey | | | |
| C 320 | 浓松叶色 | Thick pine leaf | | | |
| MC 212 | 金属灰 | Metallic gray | | | |
| MC 218 | 铝金色 | Aluminum gold | | | |



A-10C THUNDERBOLT II 雷电二式 近距离支援攻击机

CLOSE AIR SUPPORT ATTACK AIRCRAFT

零件表 PARTS LIST
パーツリスト

1/48 SCALE L4829 AIRCRAFT



A Part × 1

B Part × 1

C Part × 1

I Part × 1

H Part × 1

G Part × 1

F Part × 1

D Part × 1

O Part × 1

Q Part × 1

ALQ-131 Part × 1

AIM-9L Part × 2

J Part × 1

S Part × 1

AN/AAQ-28 Part × 1

GBU-38 Part × 4

GBU-31 Part × 1

M Part × 2

R Part × 1

N Part × 1

GBU-12 Part × 2

AN/ALQ-184 Part × 1

LAU-131 Part × 2

K Part × 1

L Part × 1

AGM-65 Part × 2

Decal A

Decal B-1

Decal B-2

PE

SPECIAL WEIGHT

阴影零件不使用
DO NOT USE THE
SHADOW PARTS

1

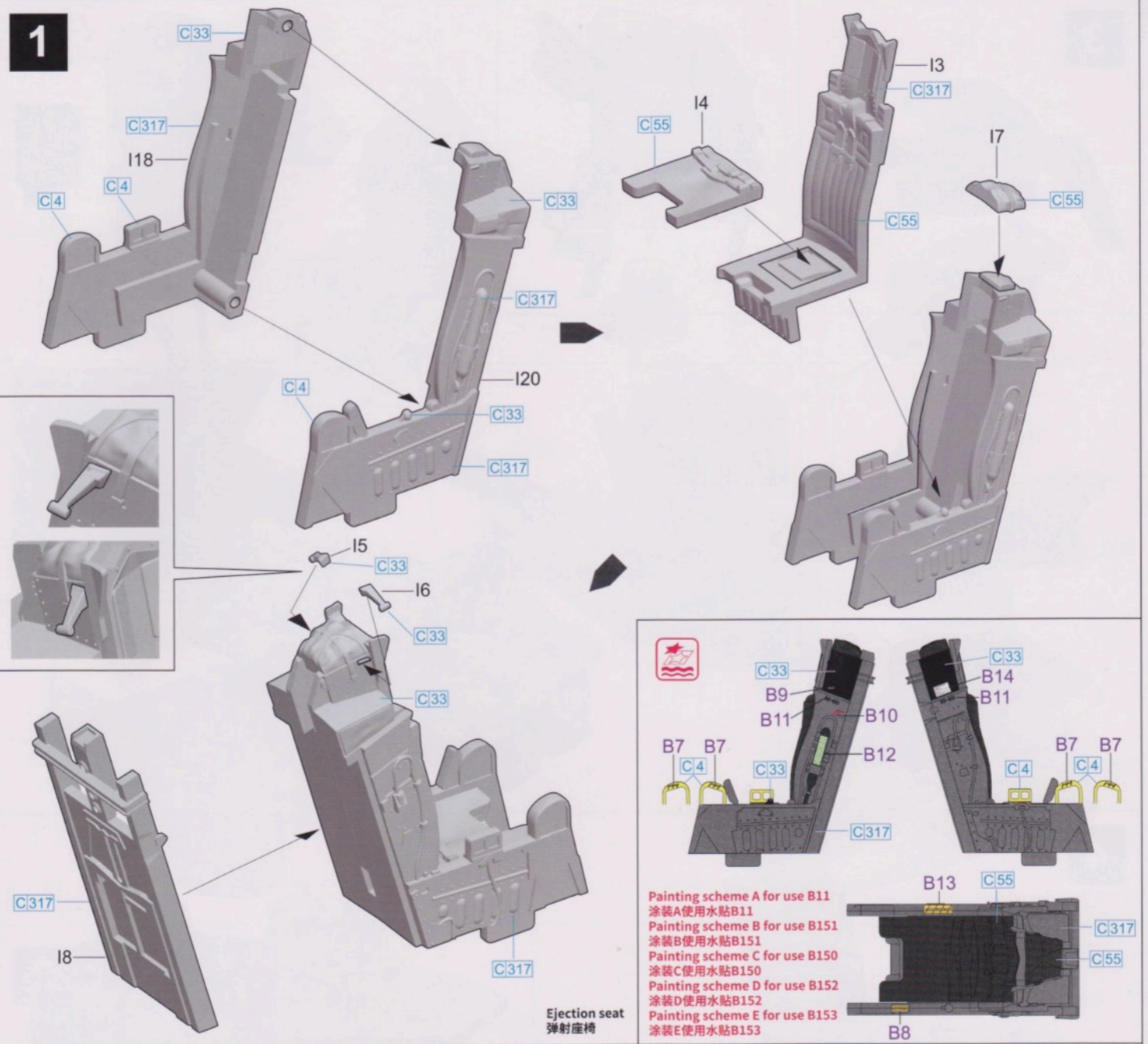

Ejection seat
弹射座椅

- Painting scheme A for use B11
涂装A使用水贴B11
- Painting scheme B for use B151
涂装B使用水贴B151
- Painting scheme C for use B150
涂装C使用水贴B150
- Painting scheme D for use B152
涂装D使用水贴B152
- Painting scheme E for use B153
涂装E使用水贴B153

2

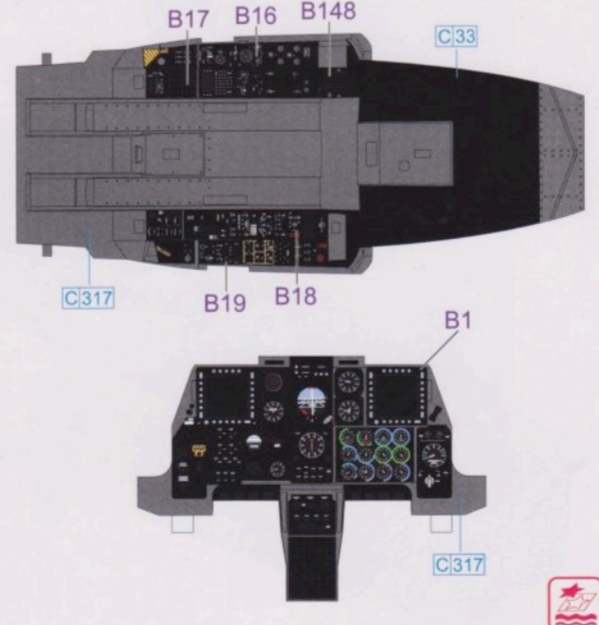
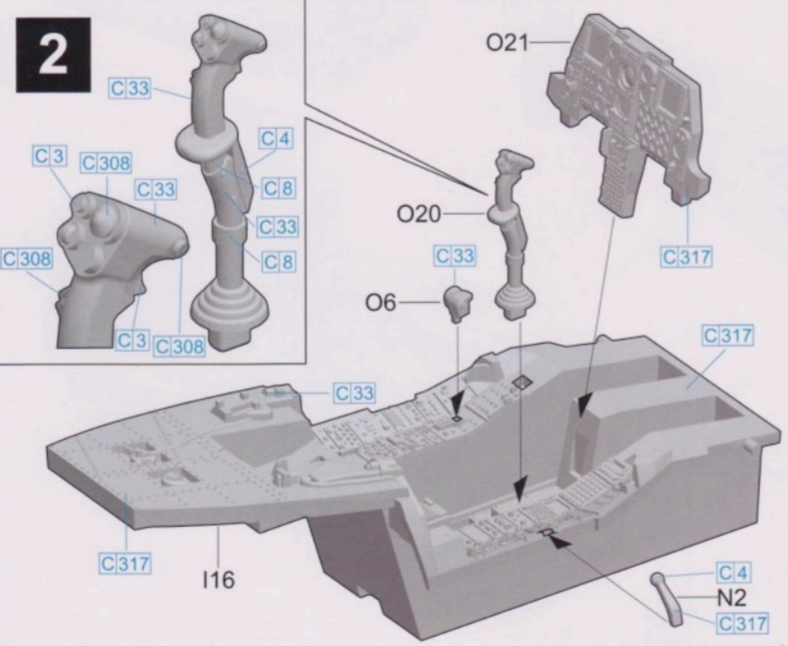

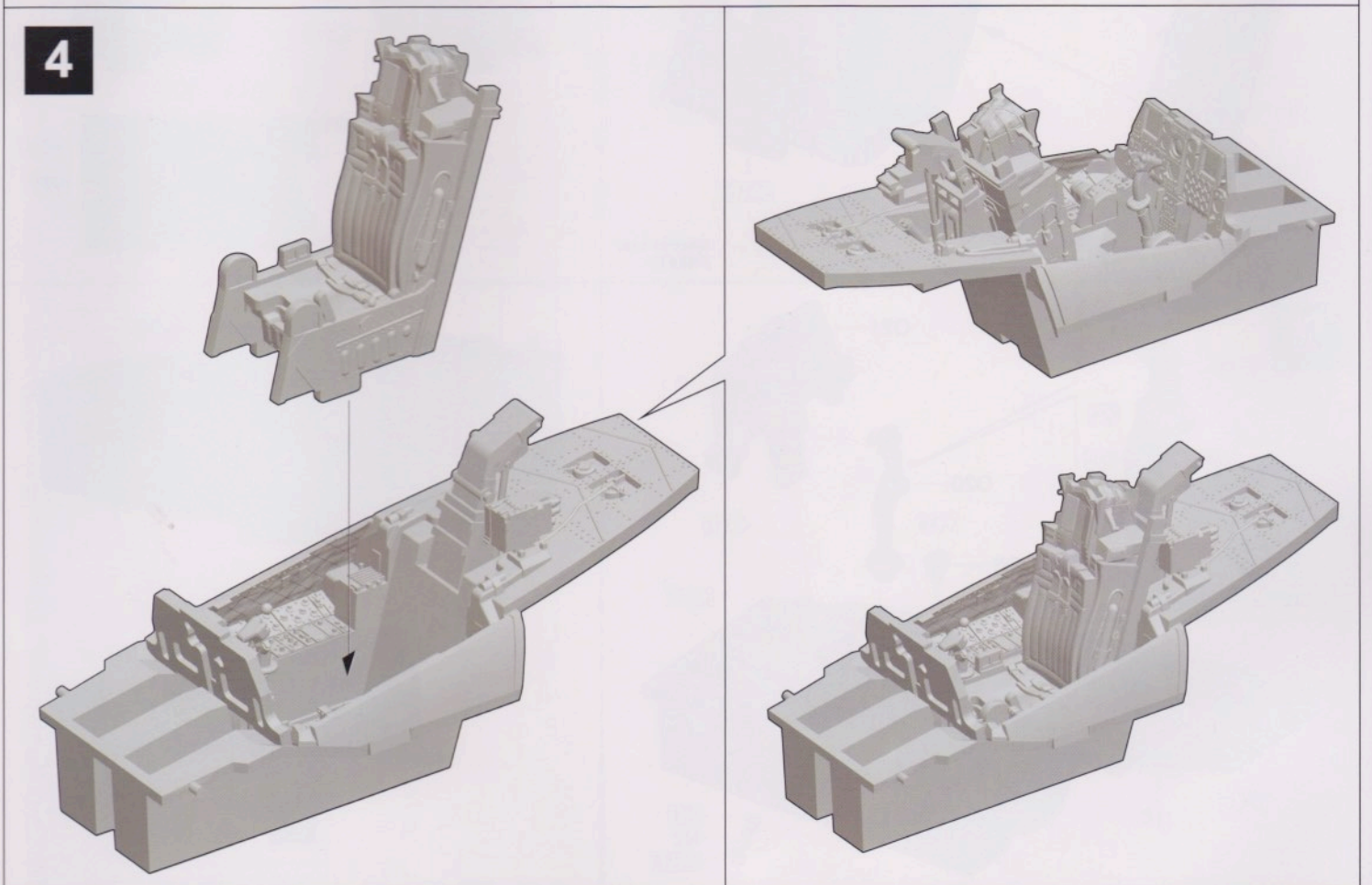
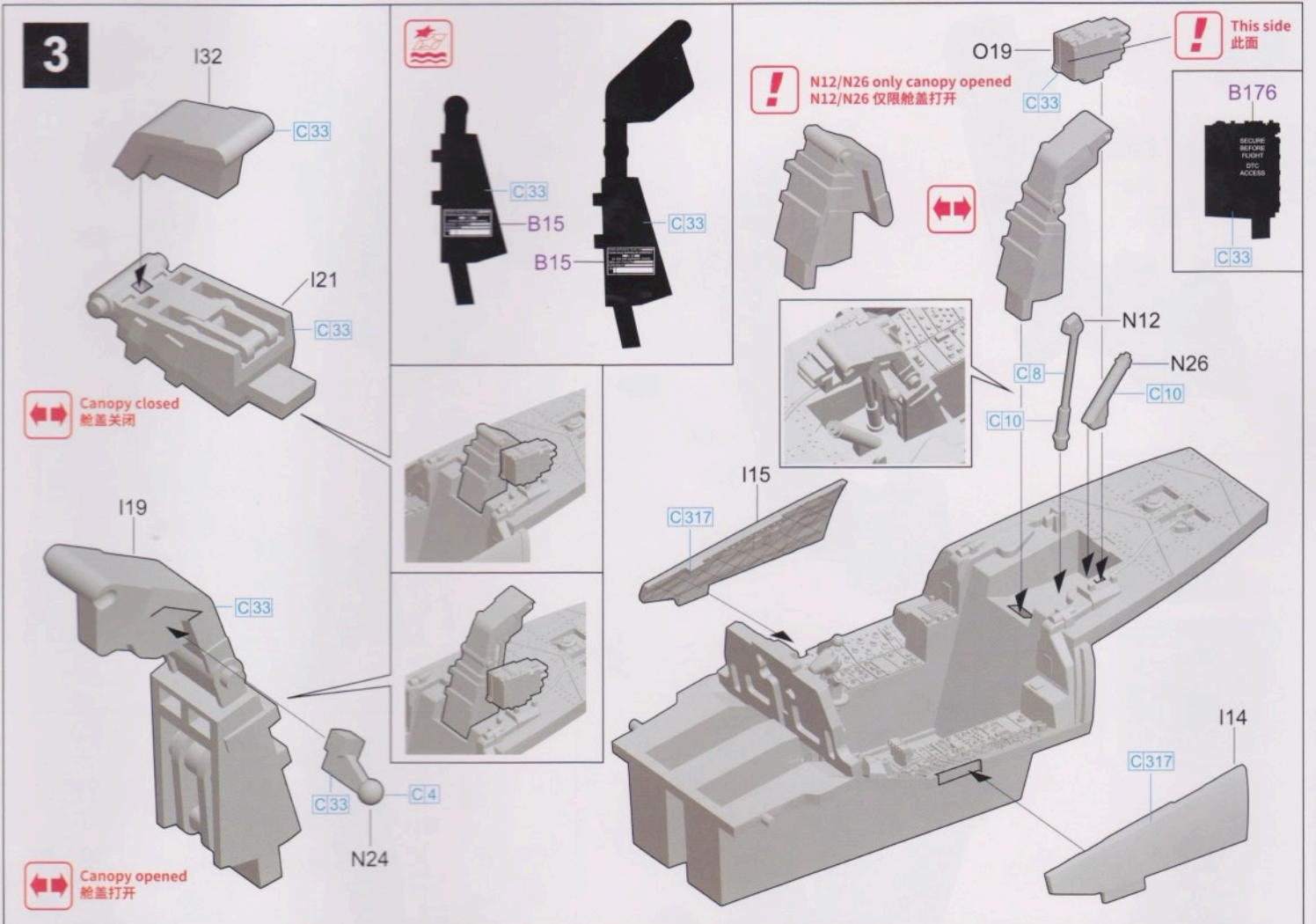

5

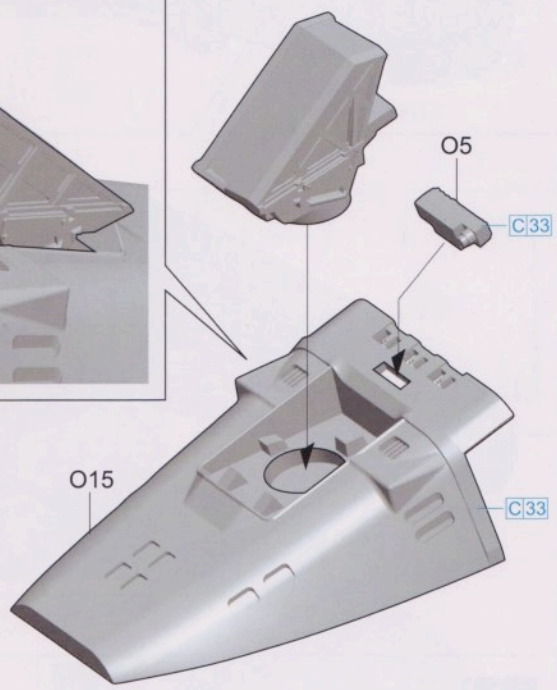
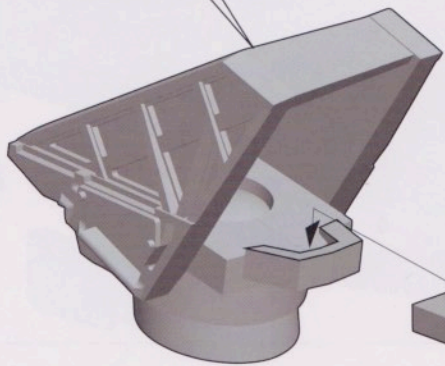
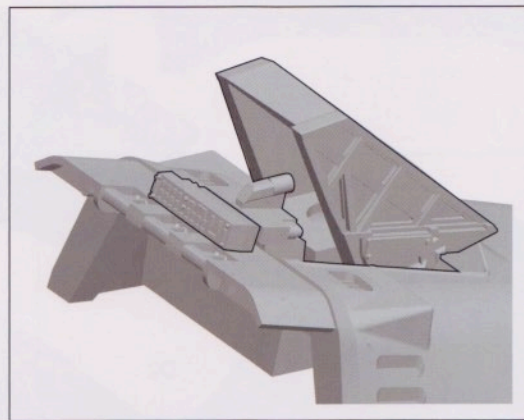
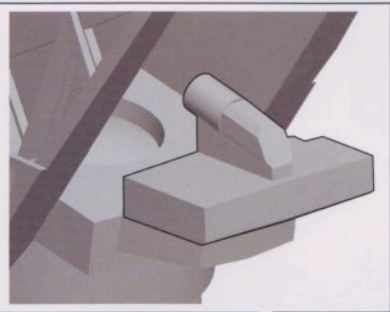
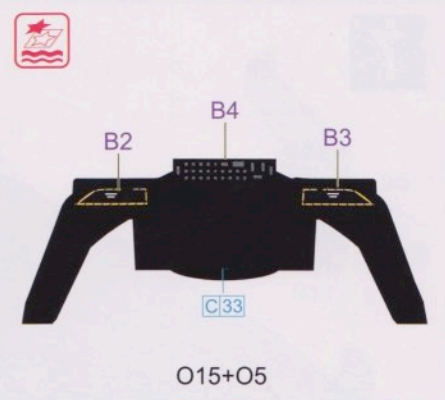
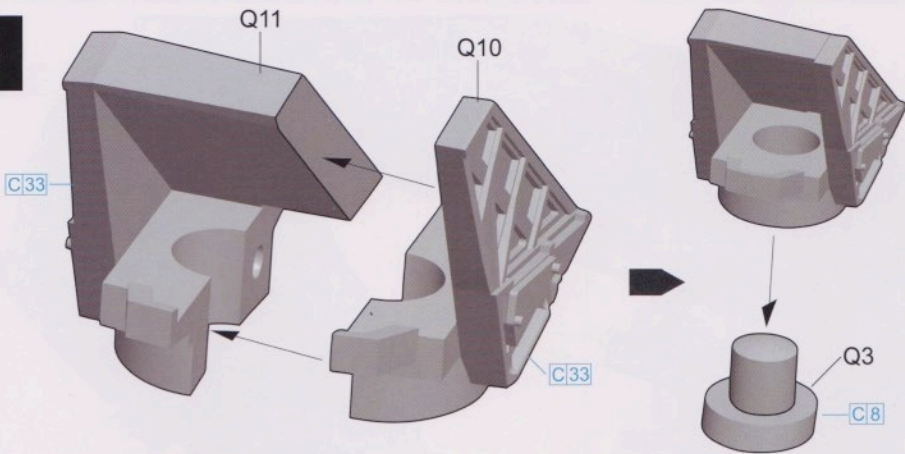

6

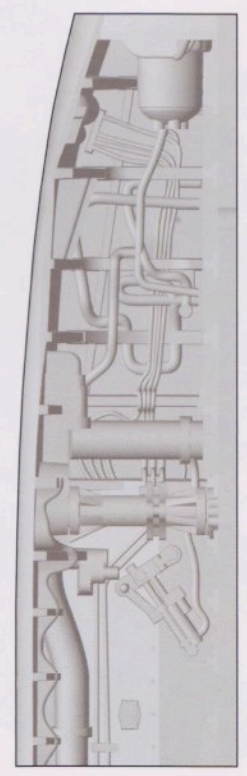
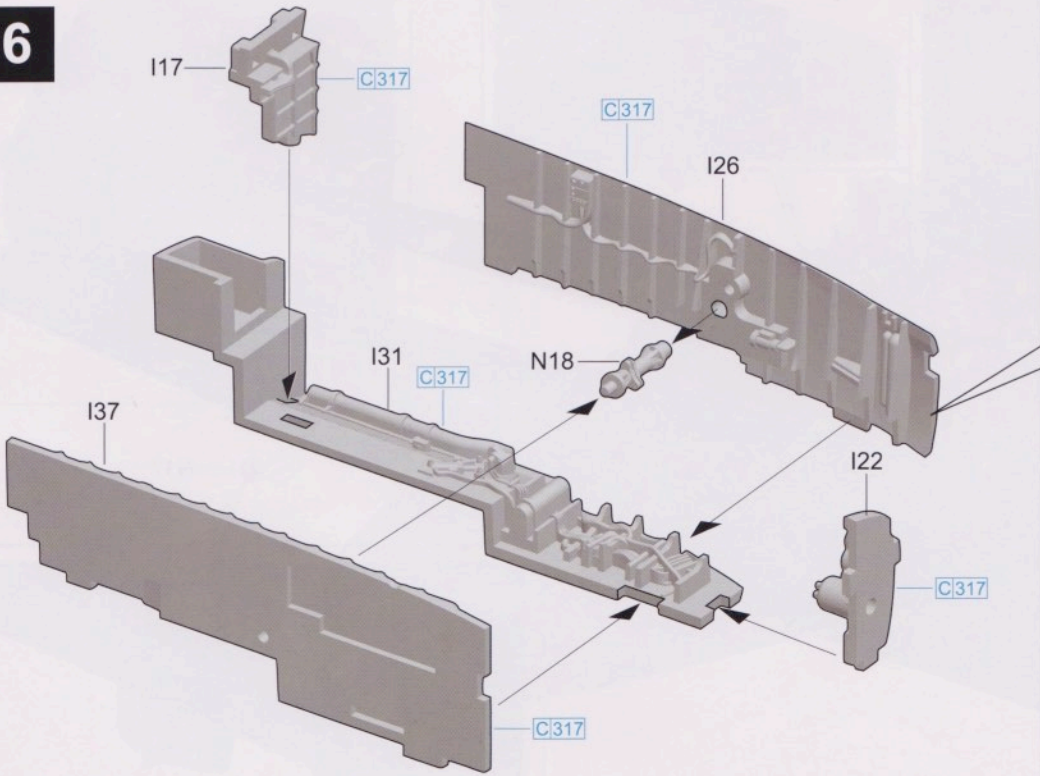

7

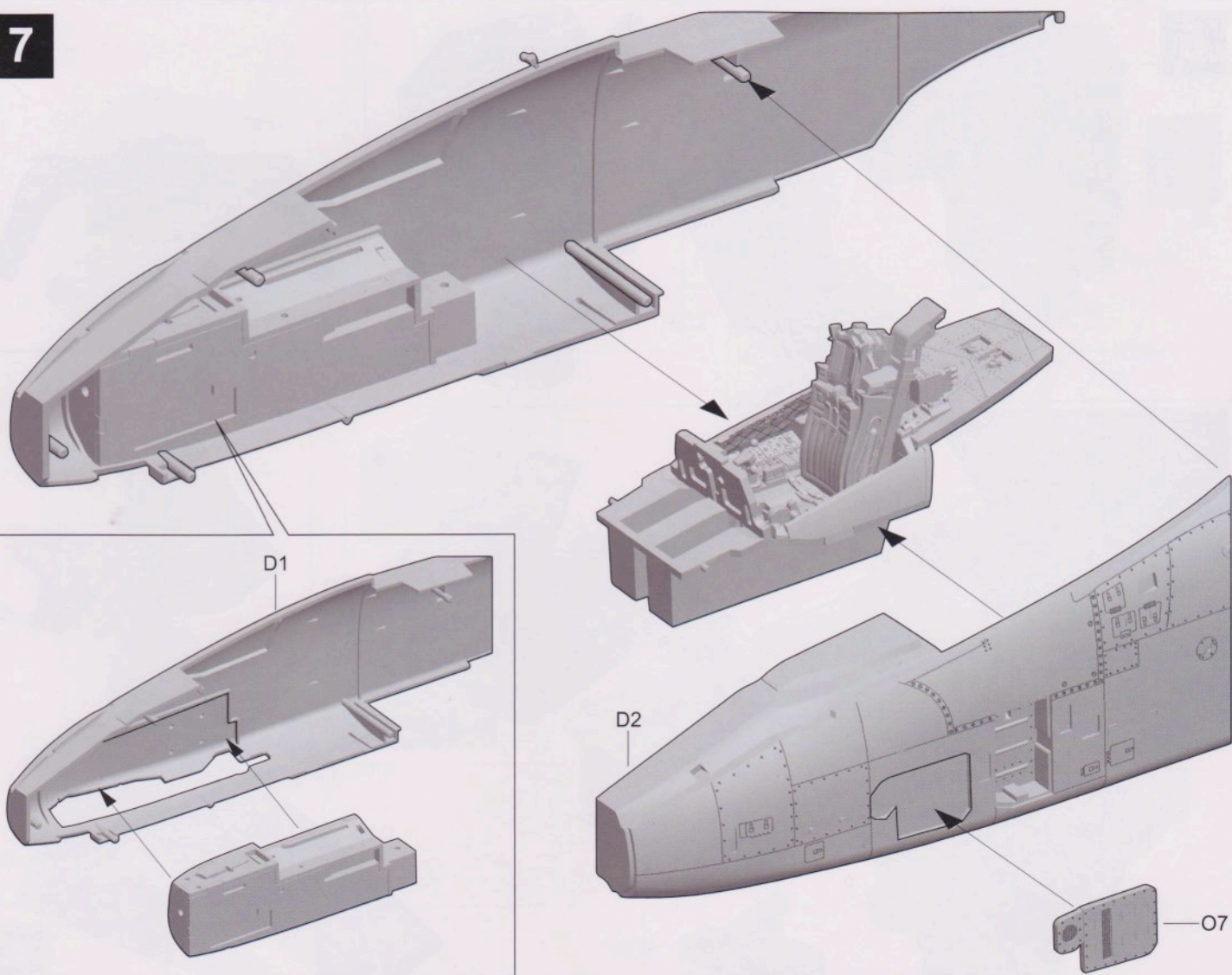

8

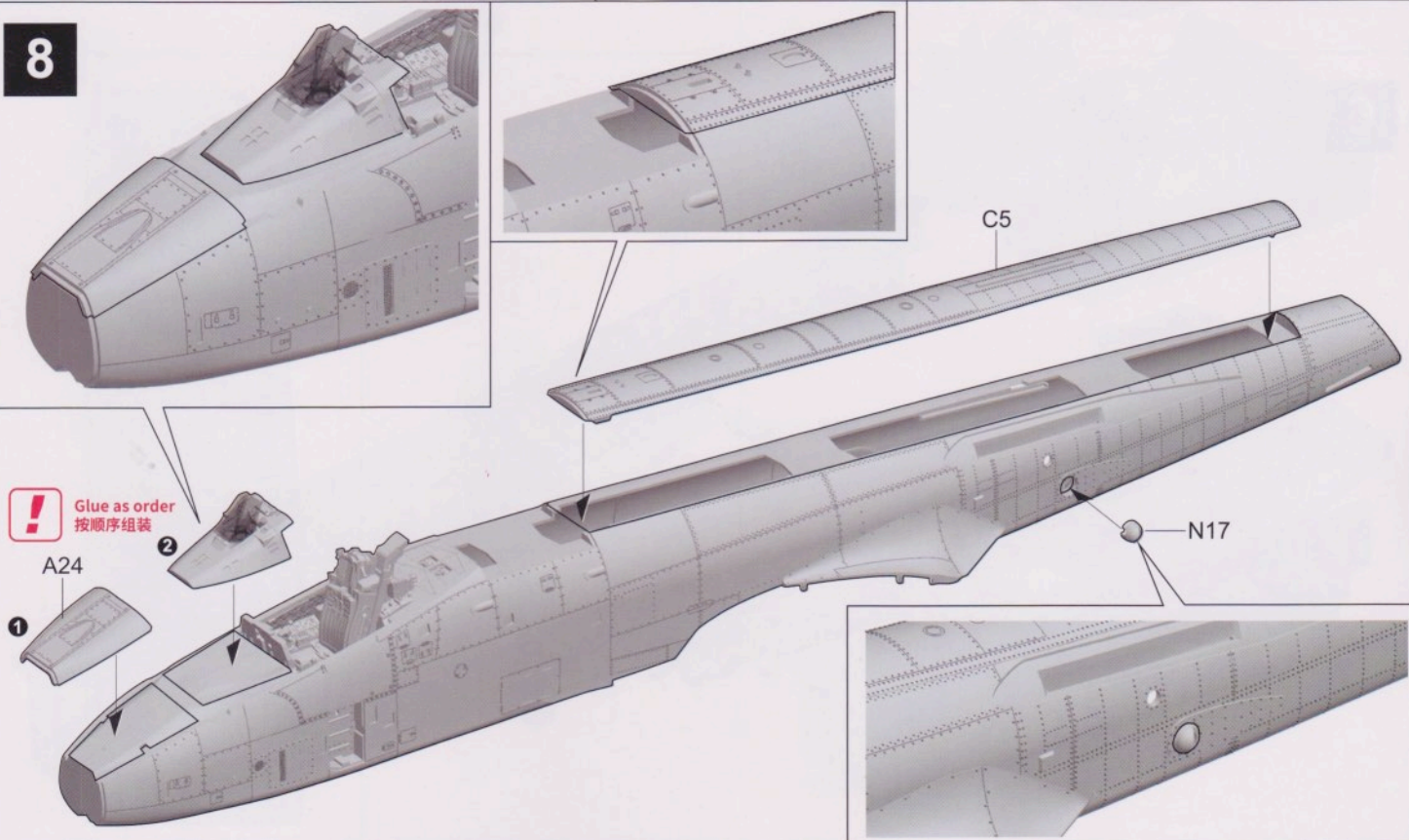

9

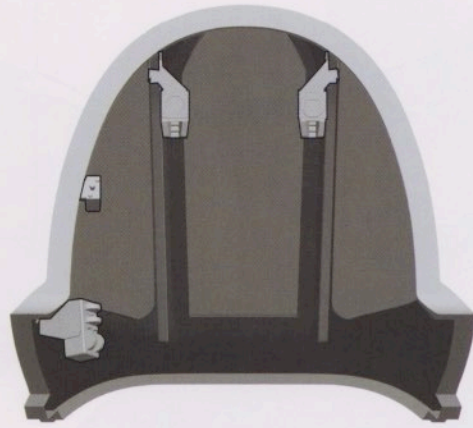
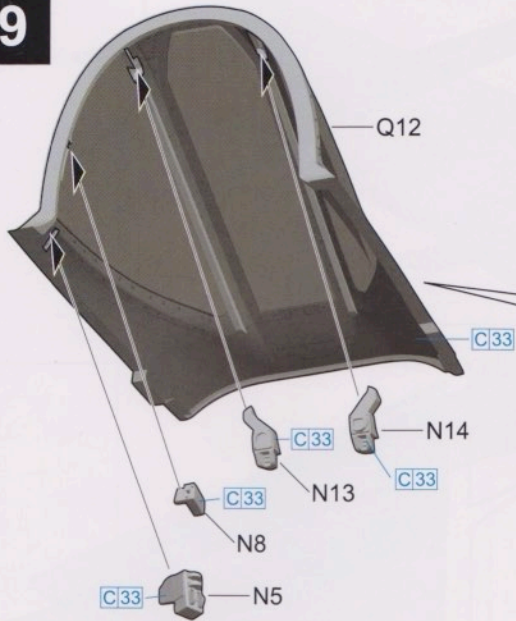

10

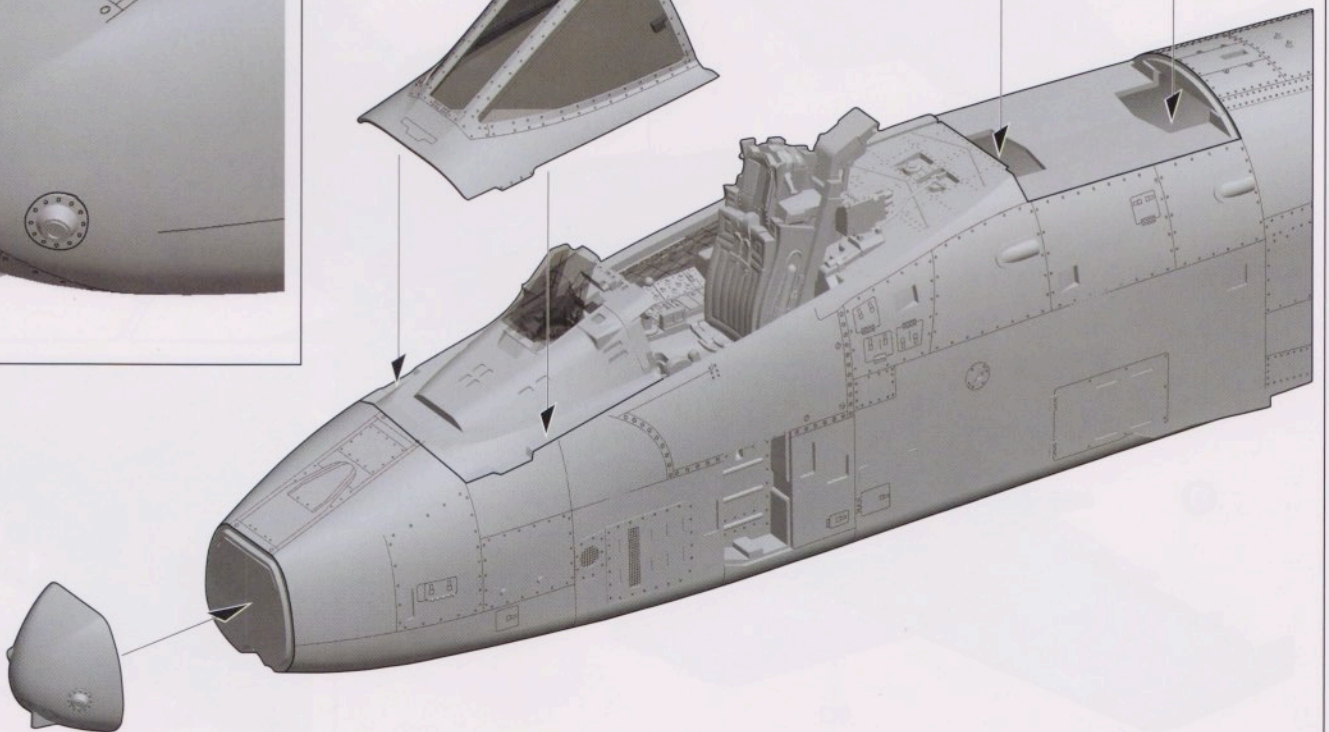
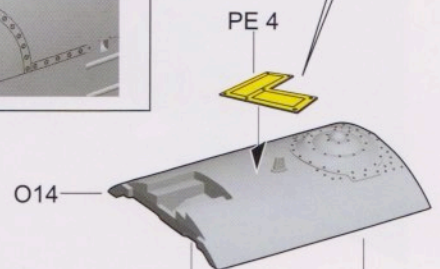
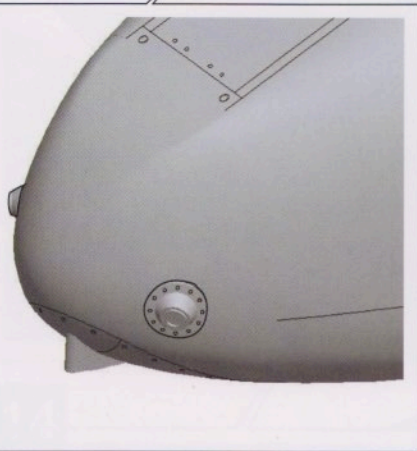
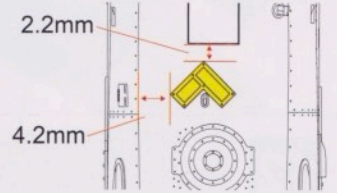
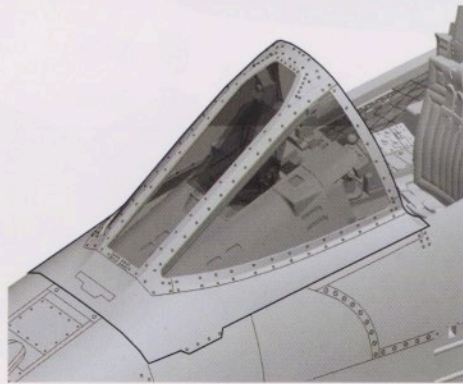
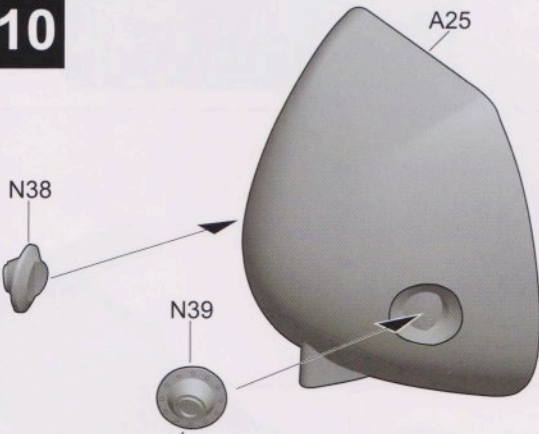

11

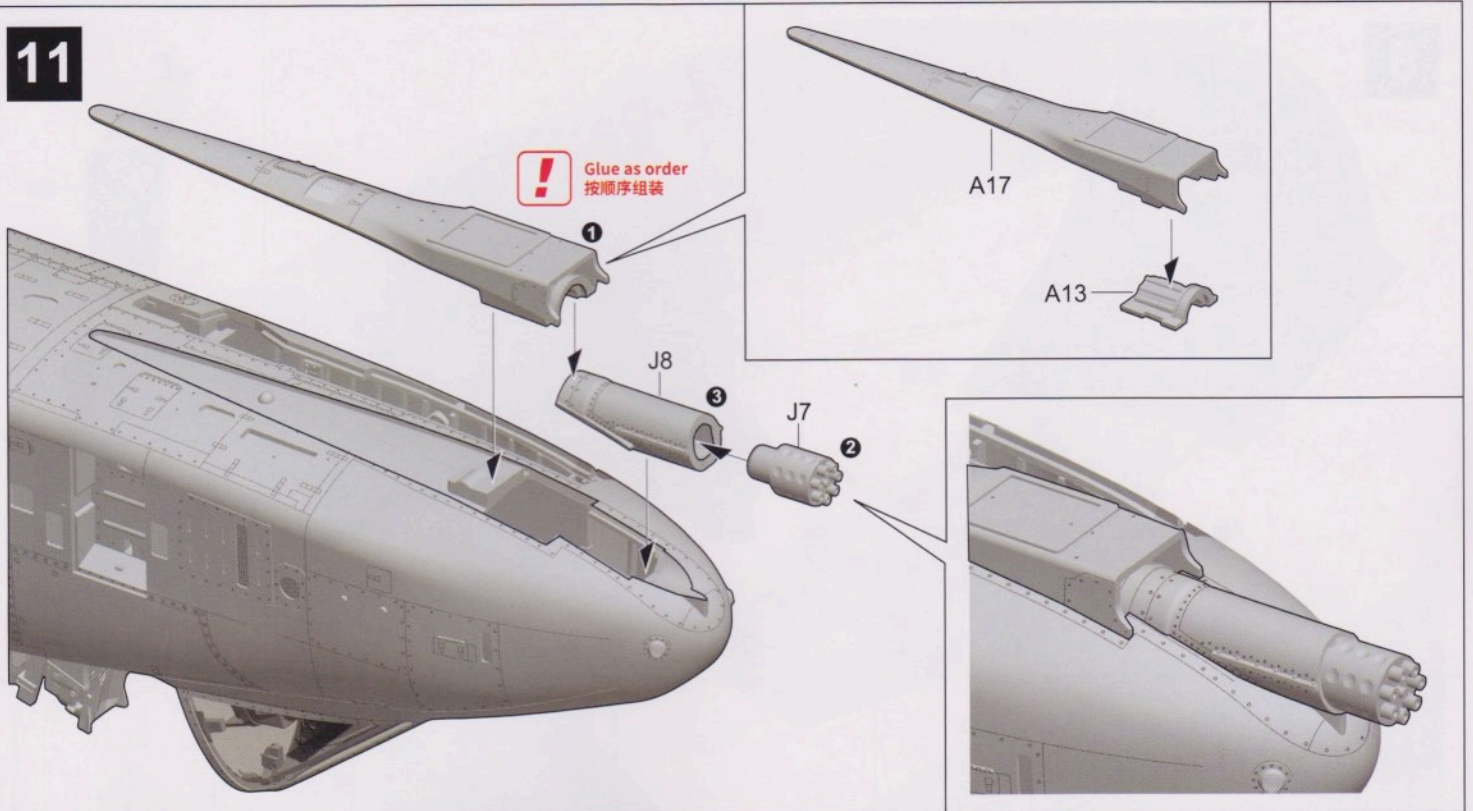

12

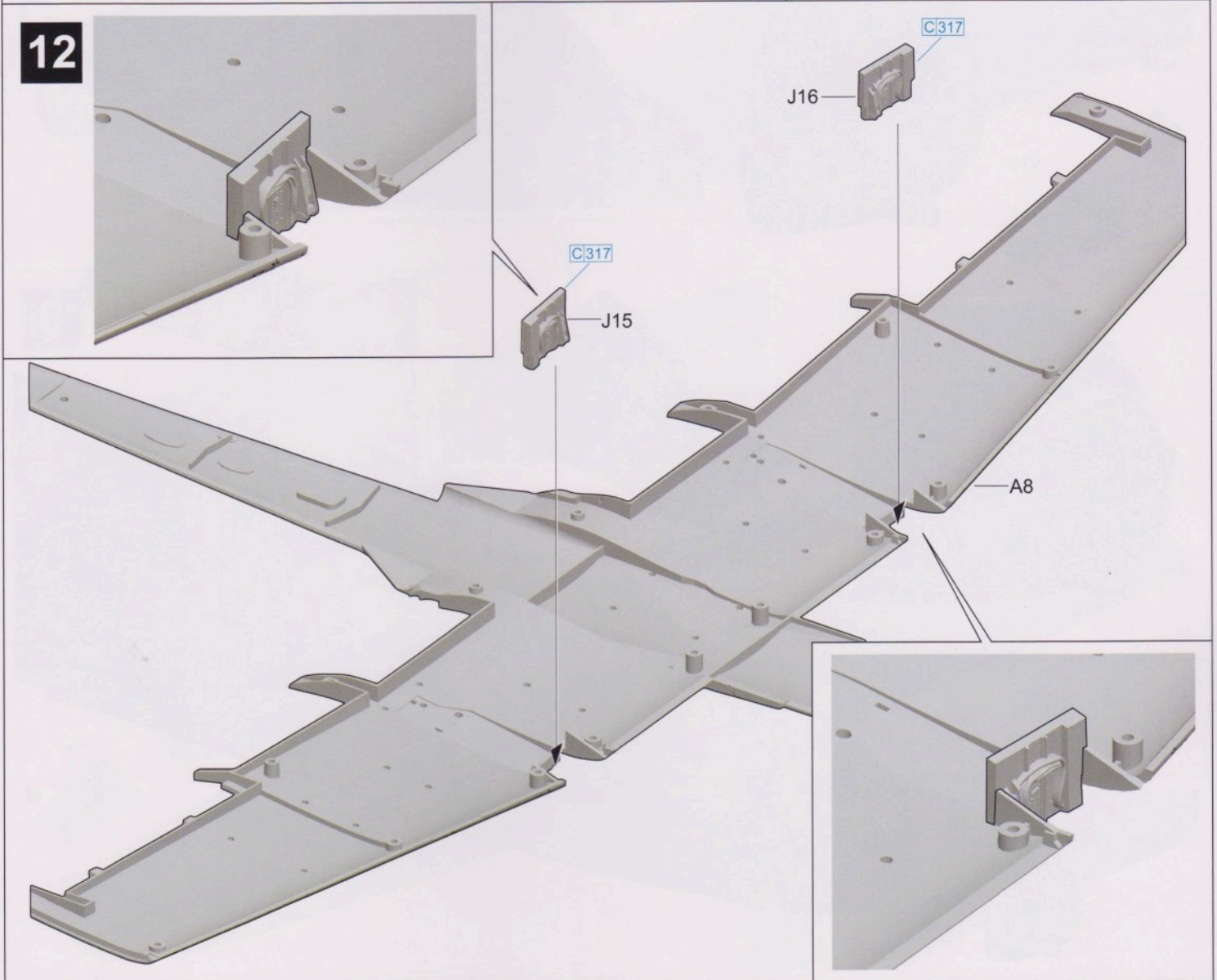

13

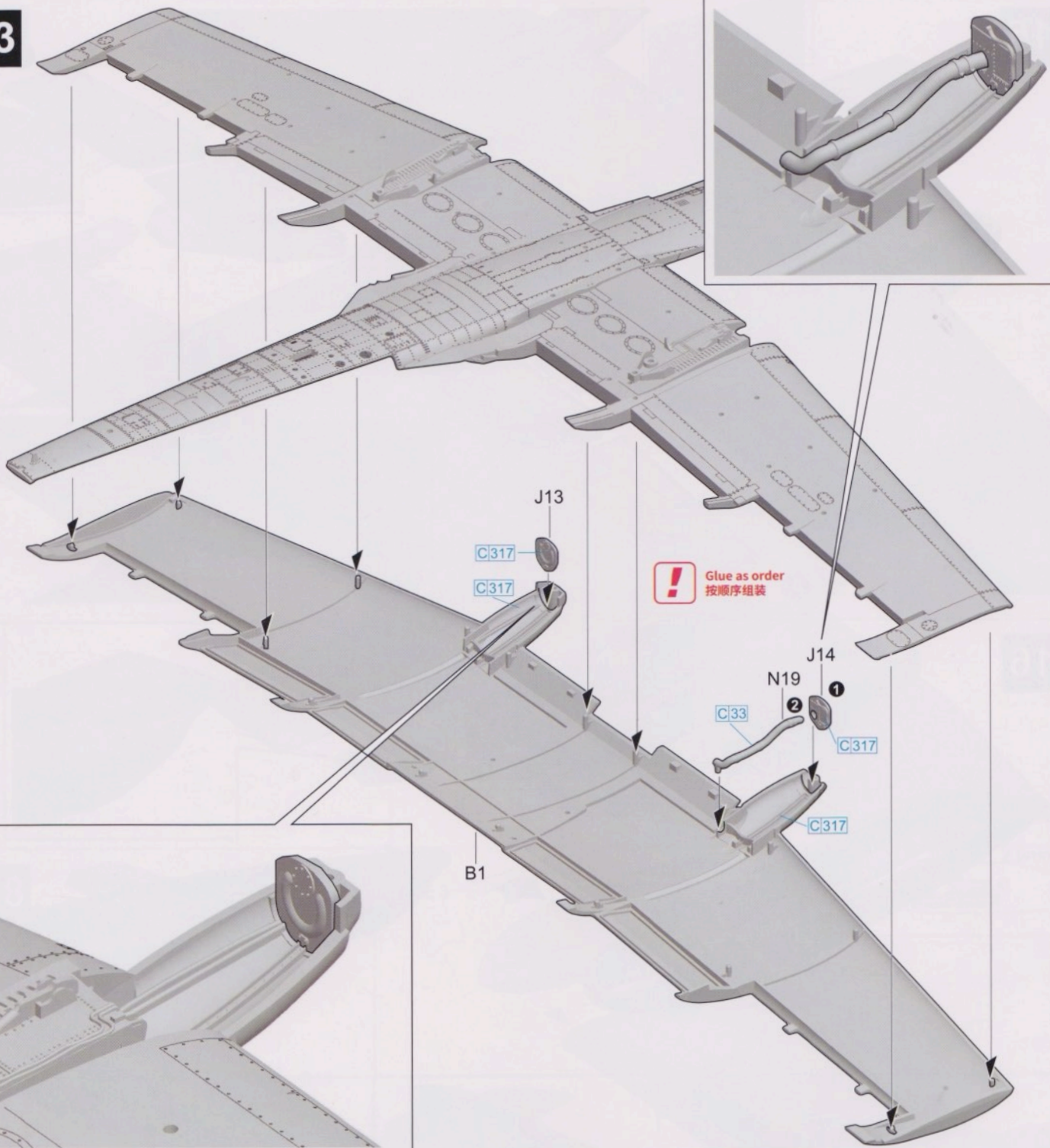

14

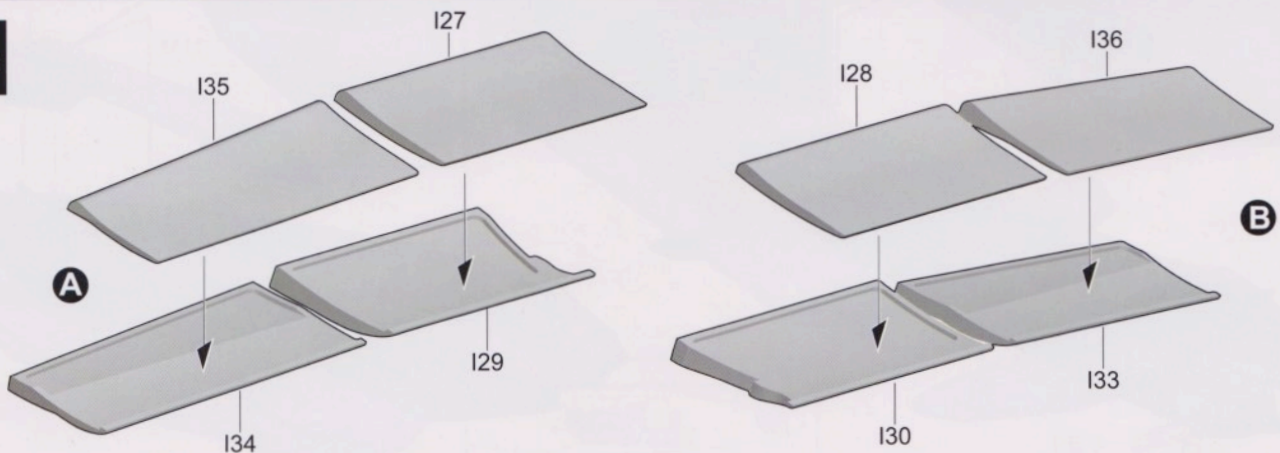

15

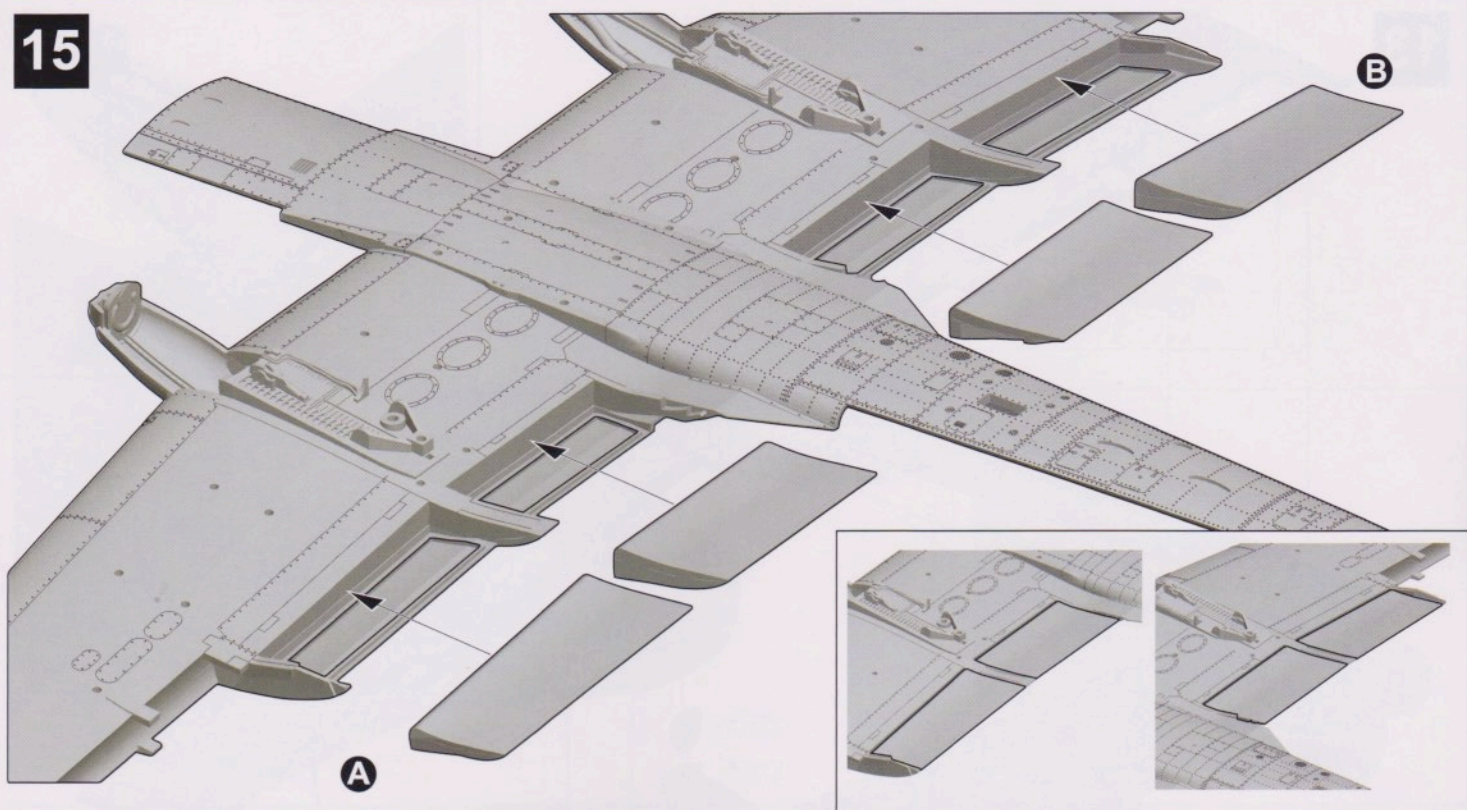

16

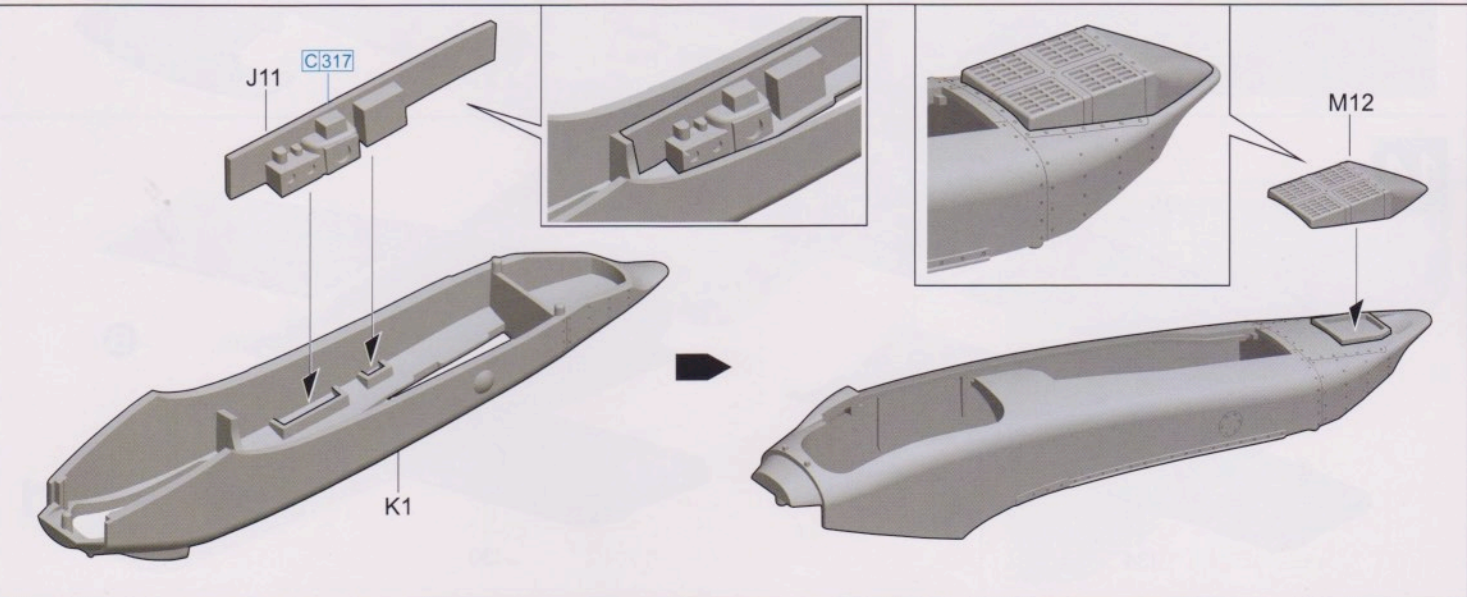
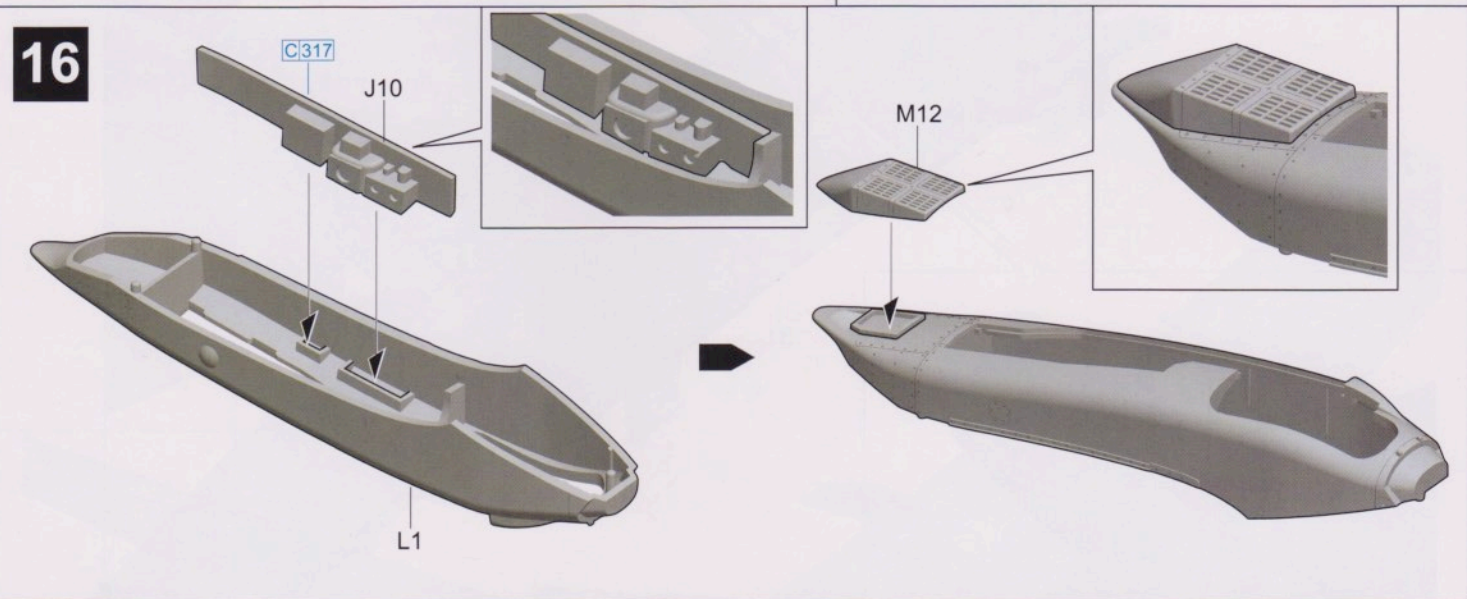

17

Glue as order
按顺序组装

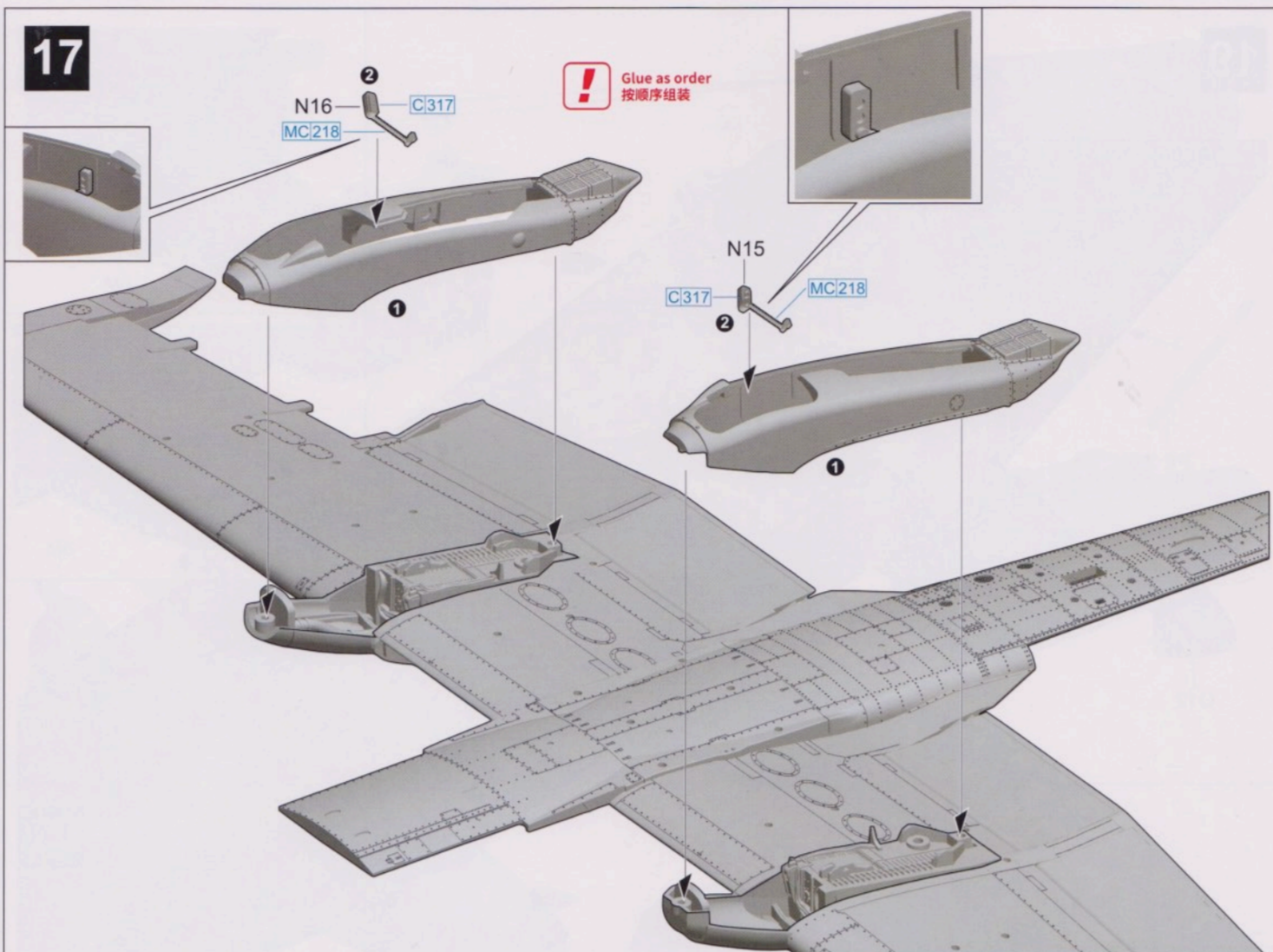

18

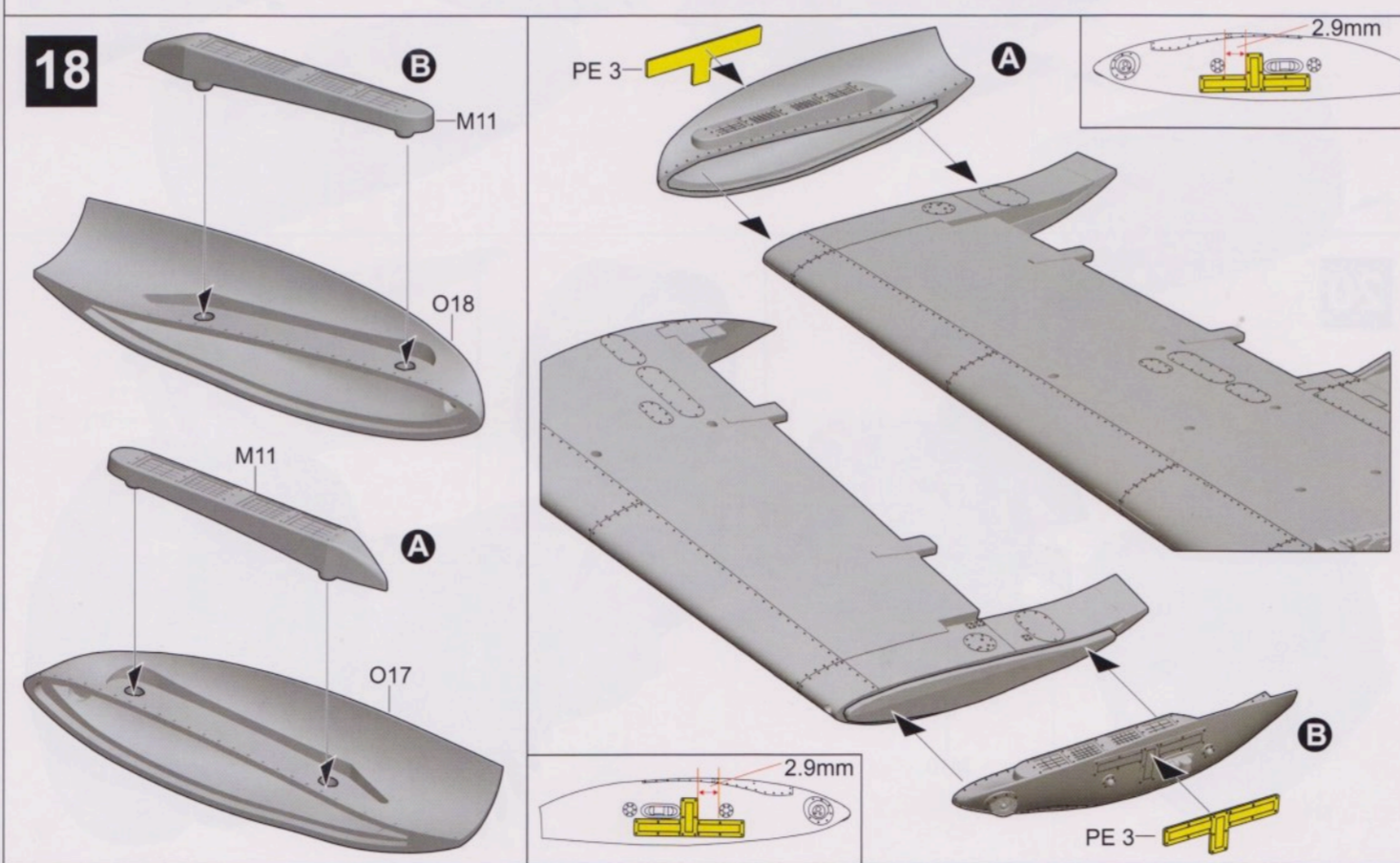

19

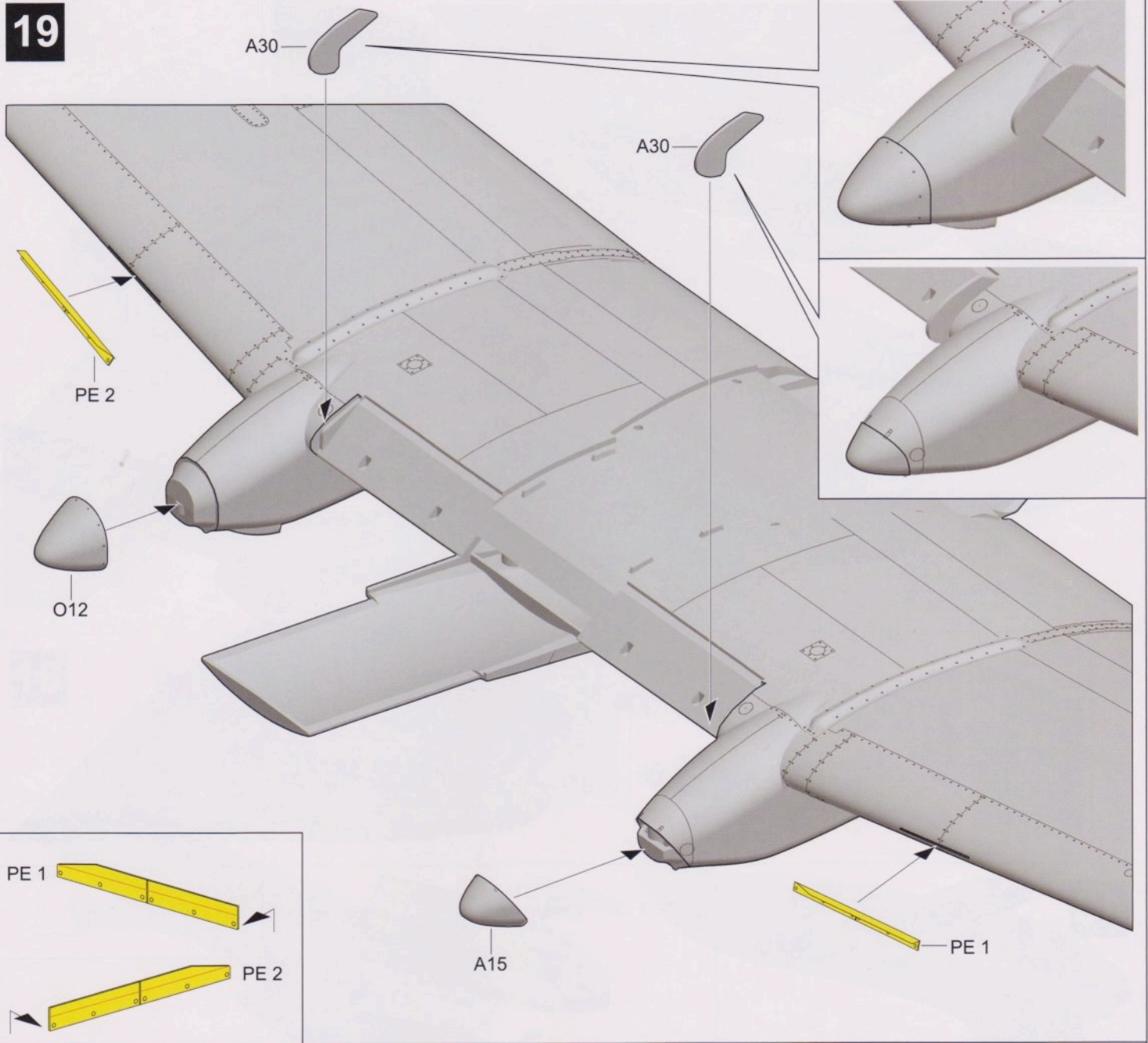

20

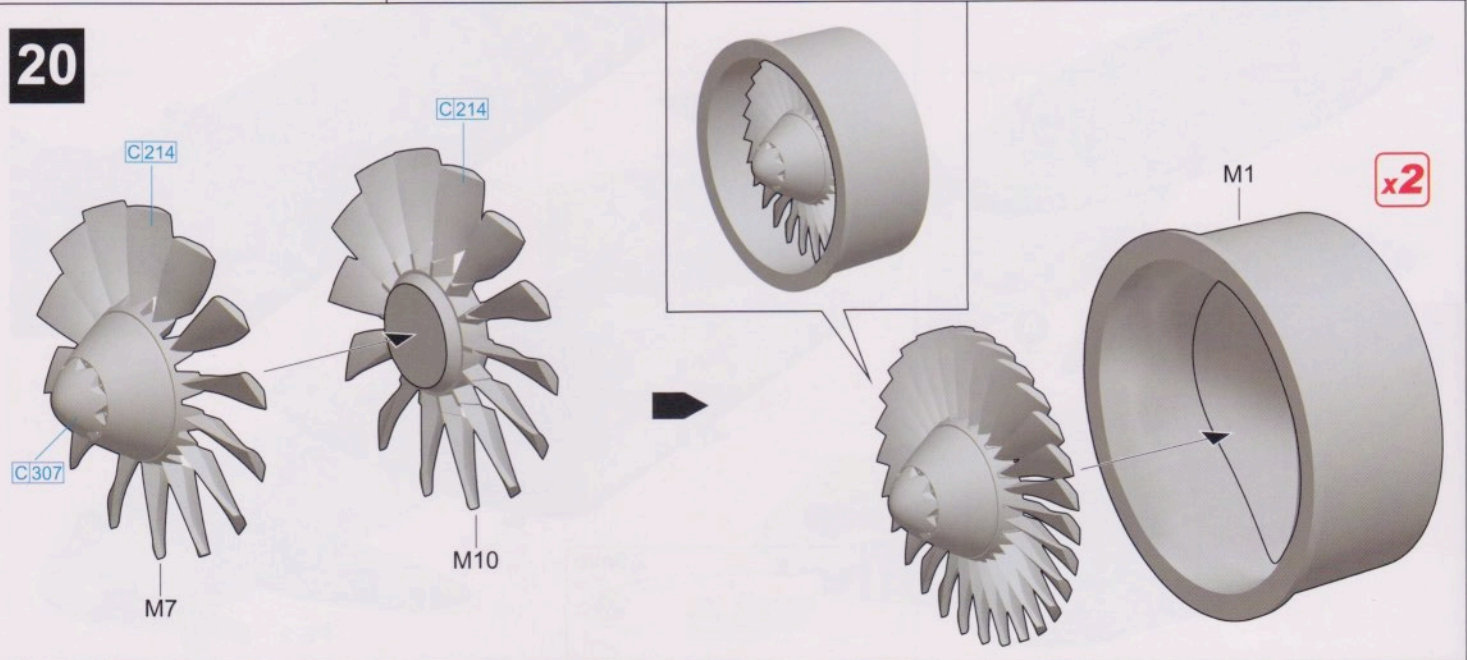

20

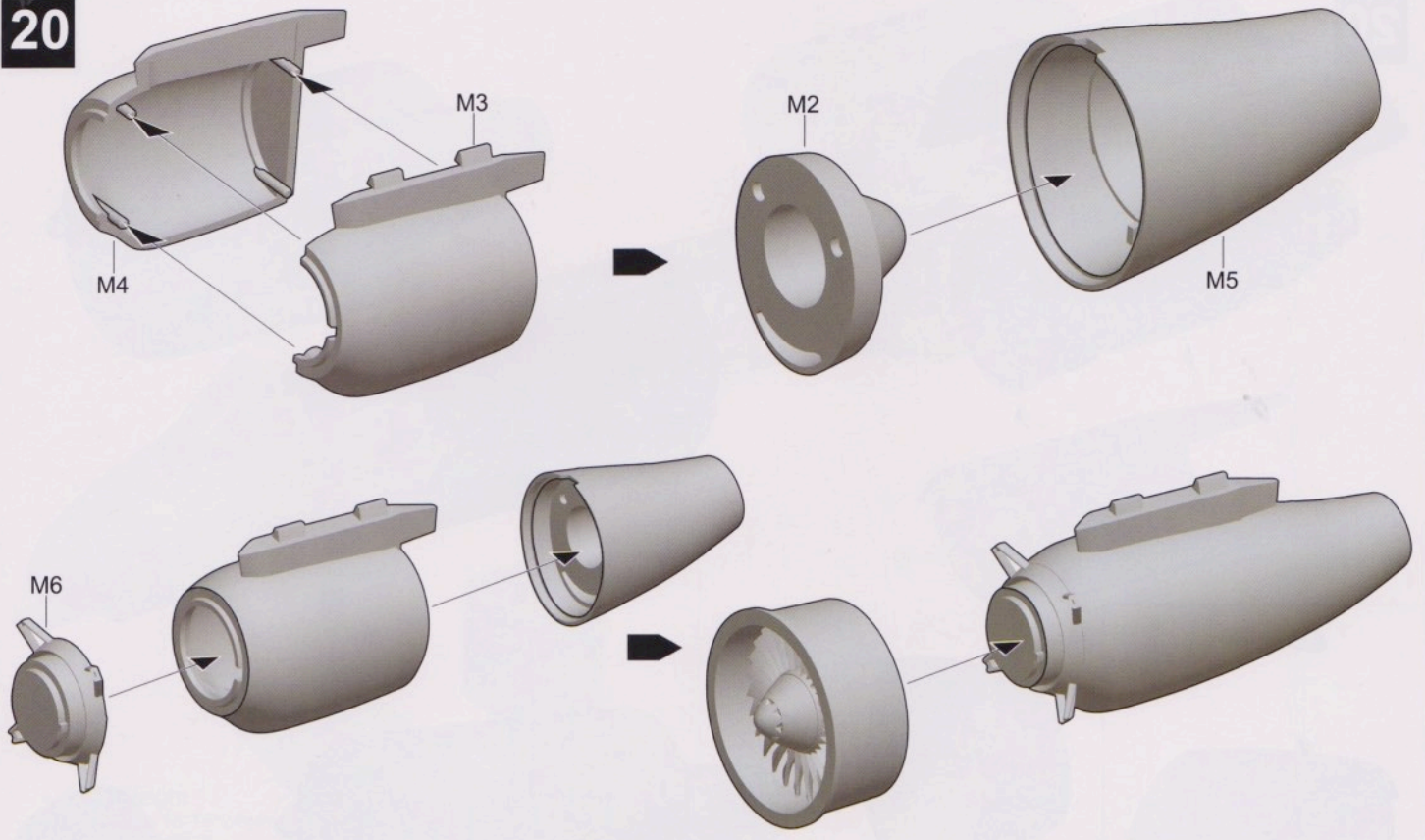

20

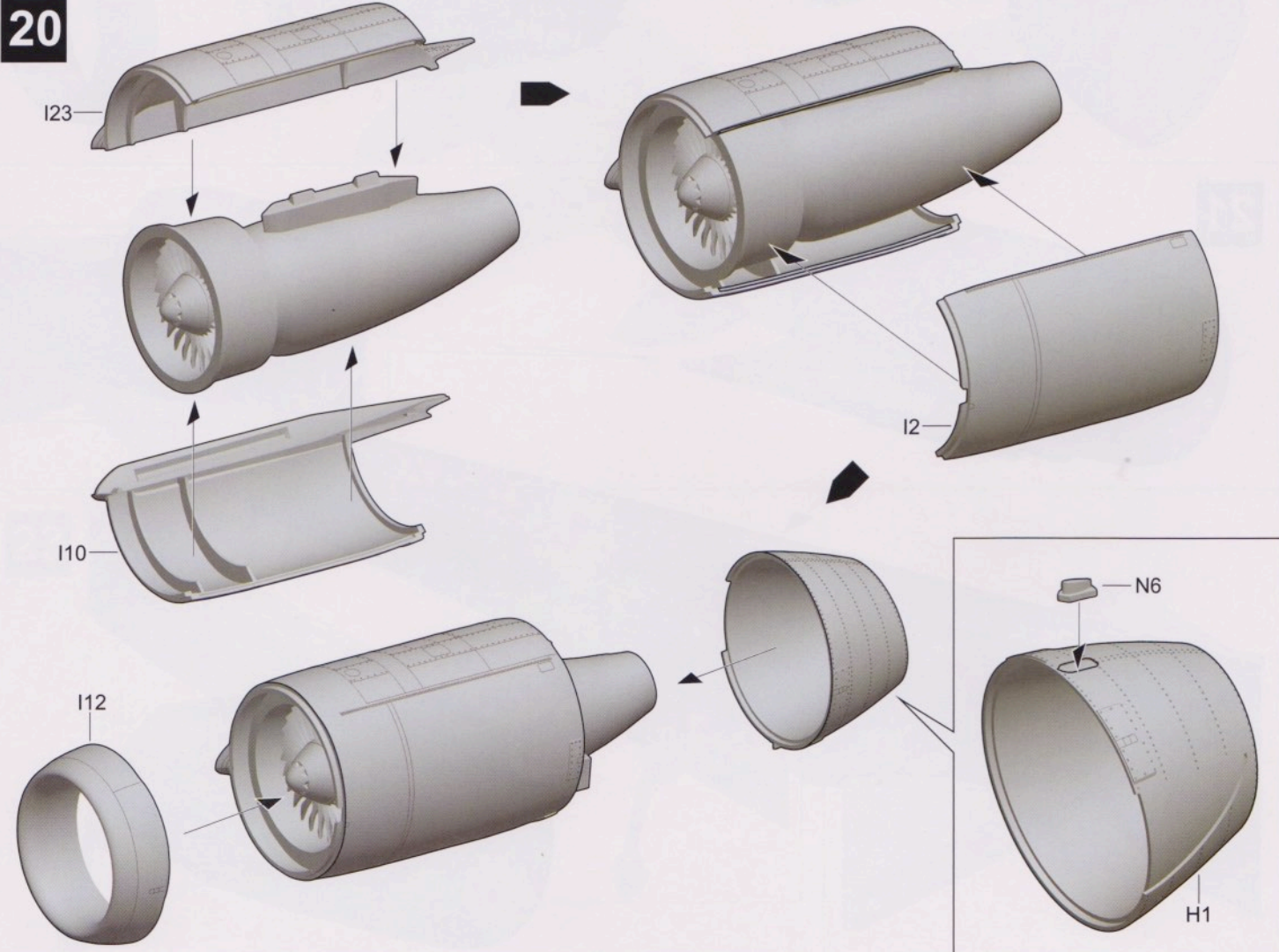

20

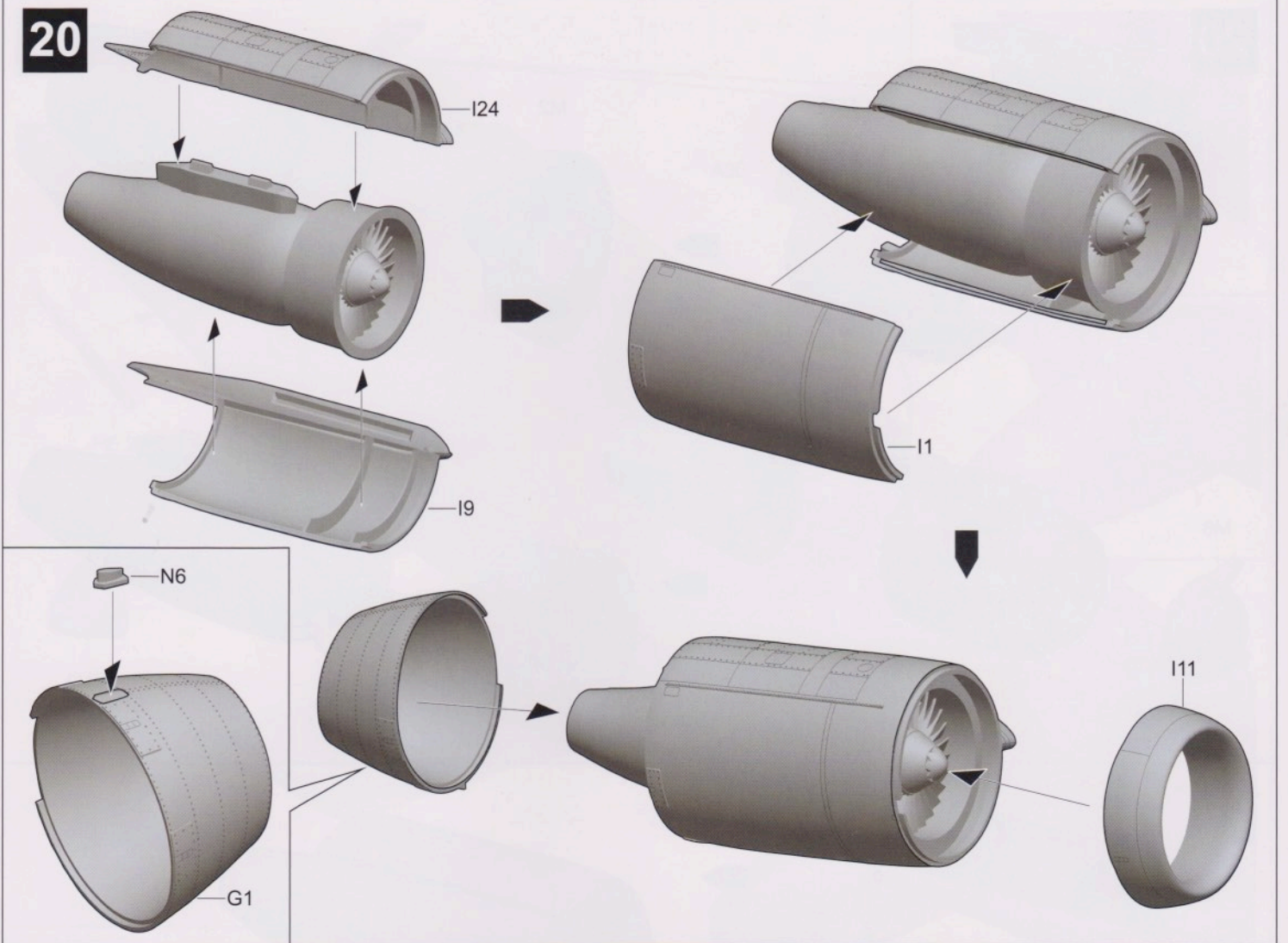

21

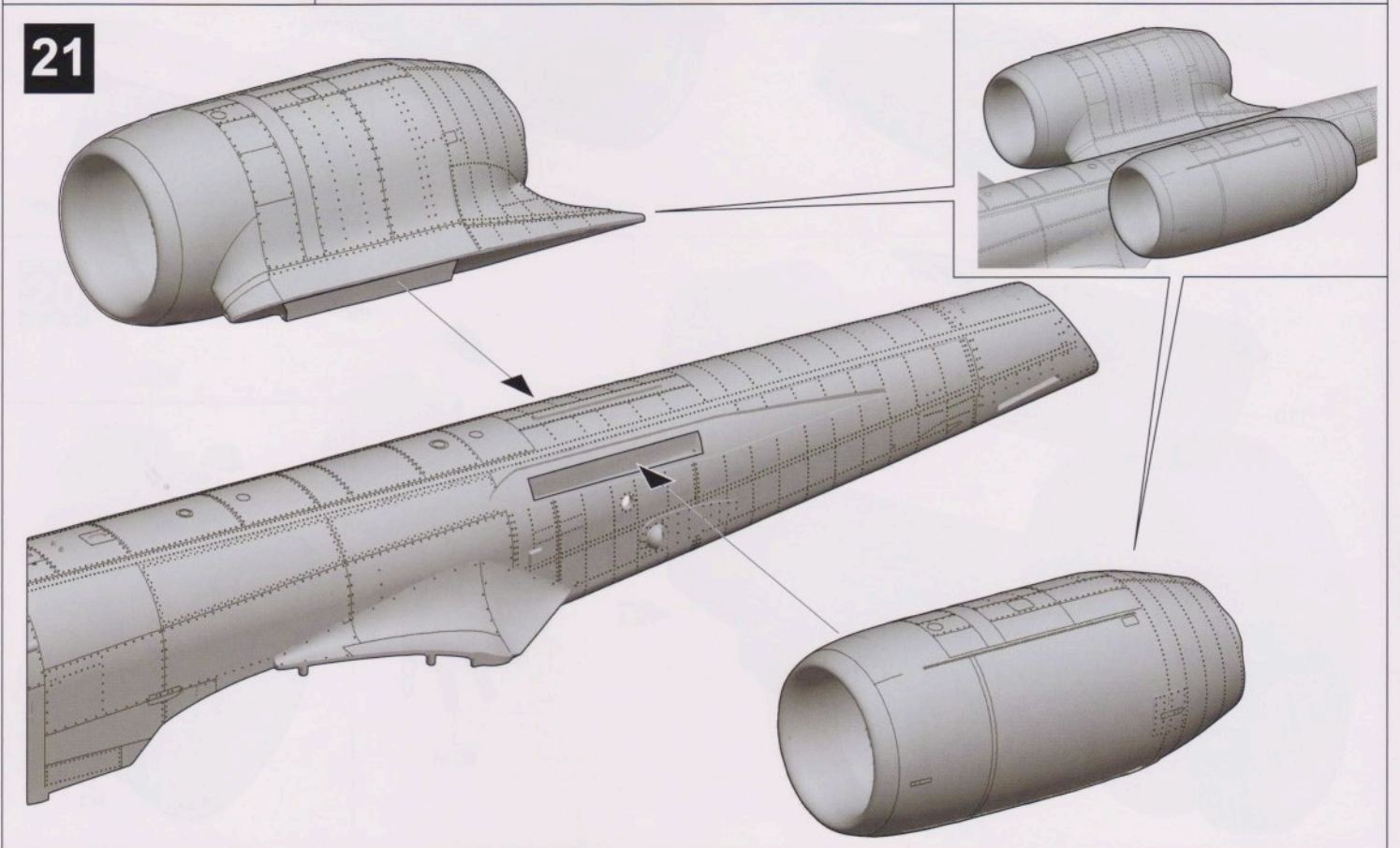

22

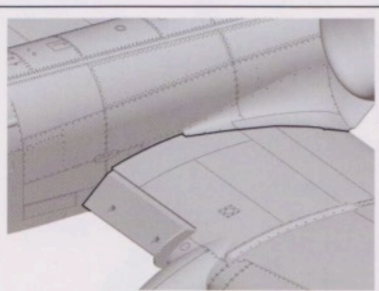
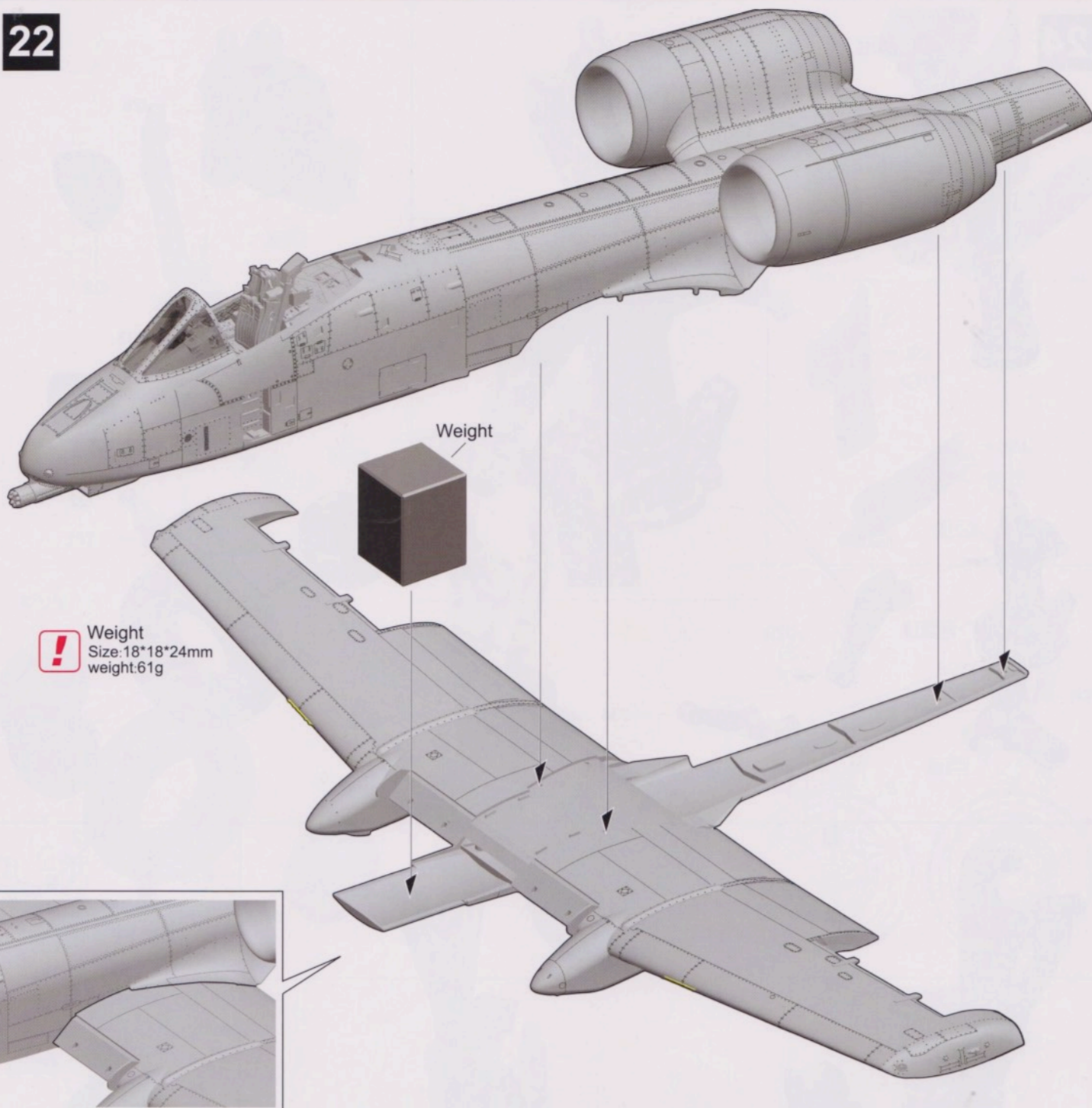

23

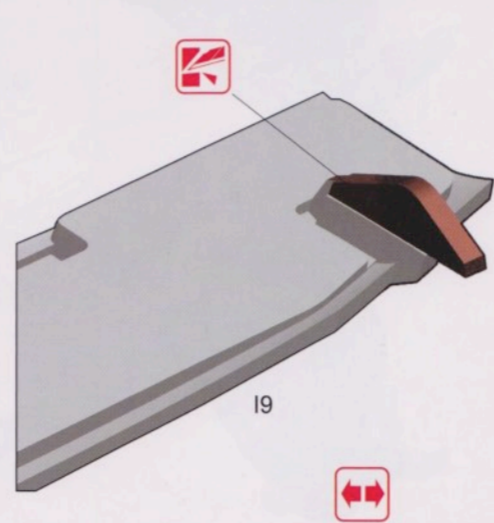
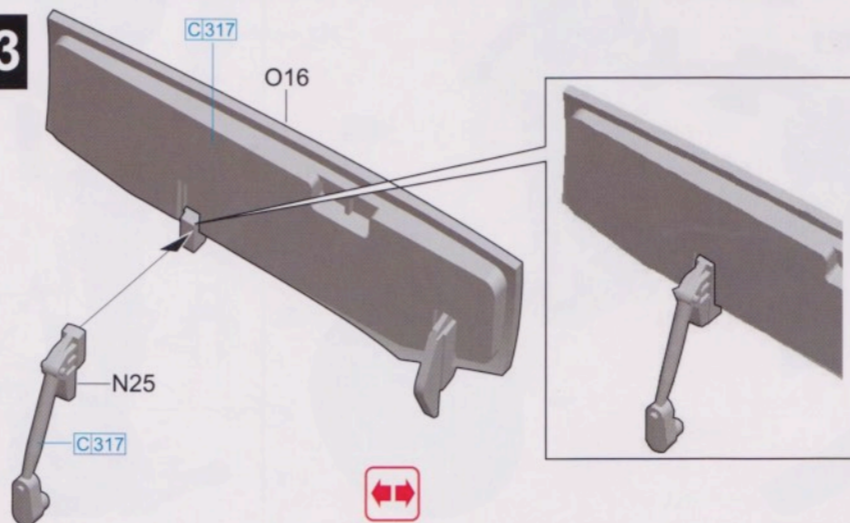

24

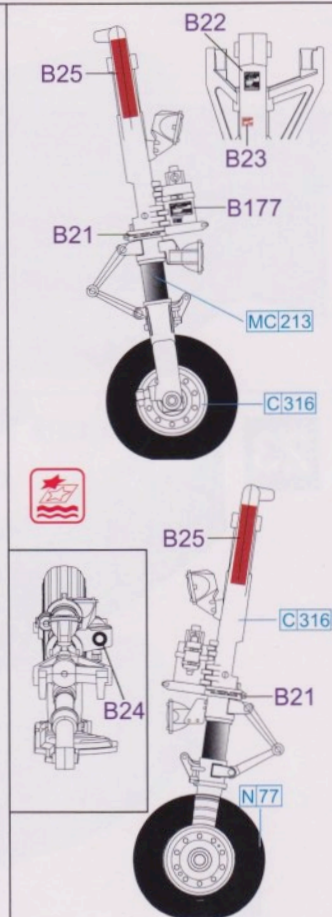
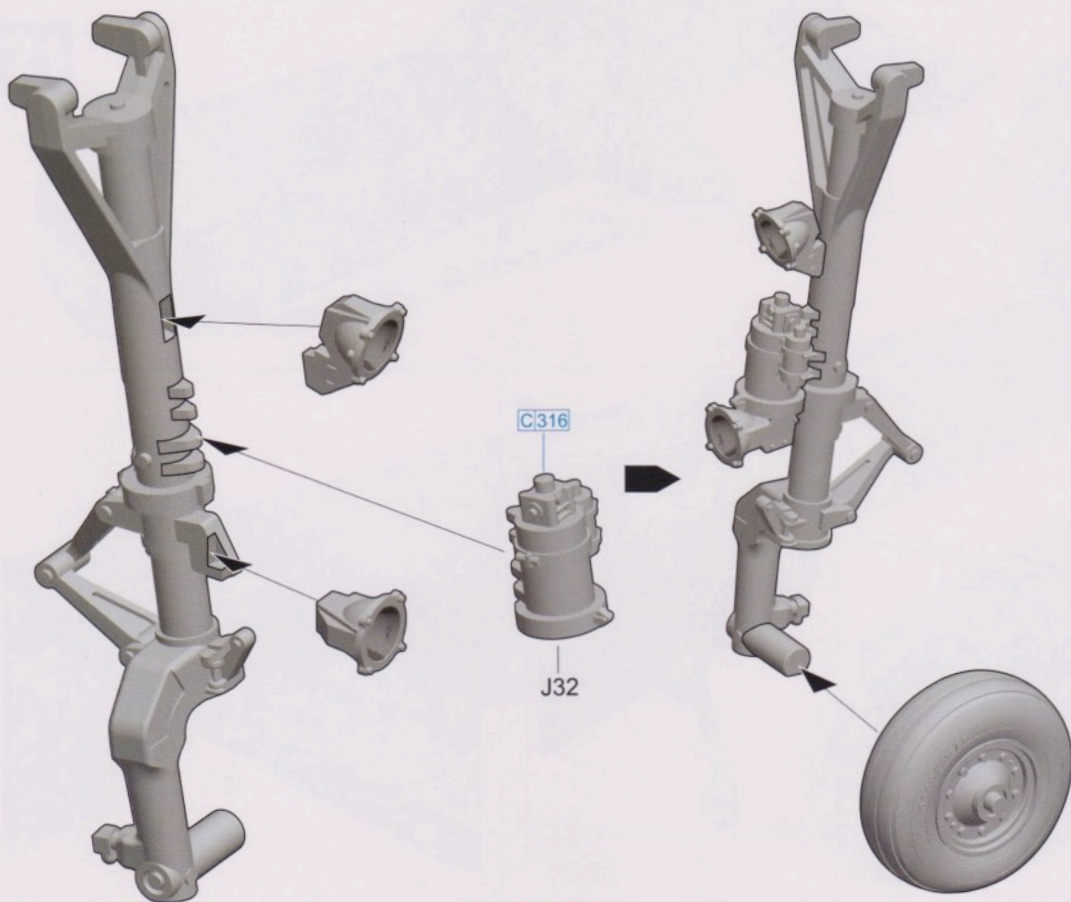
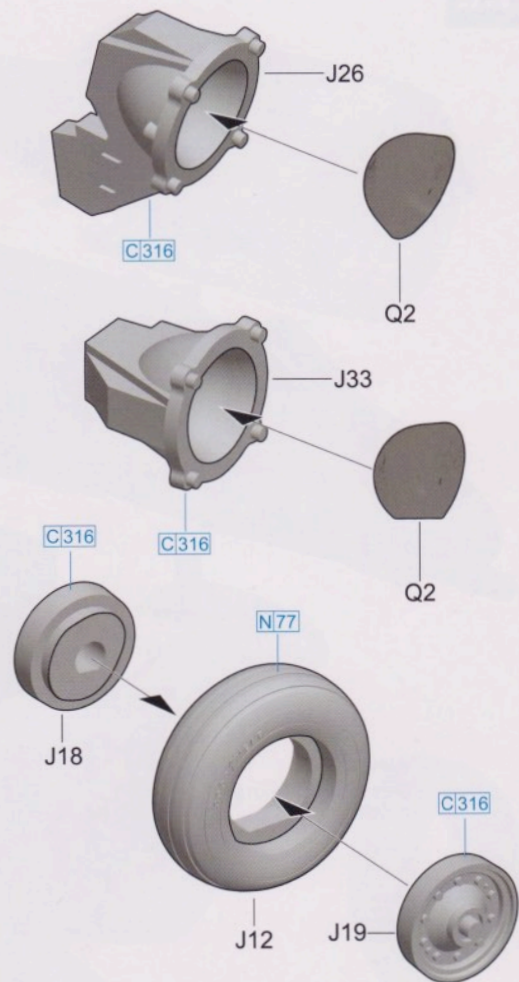
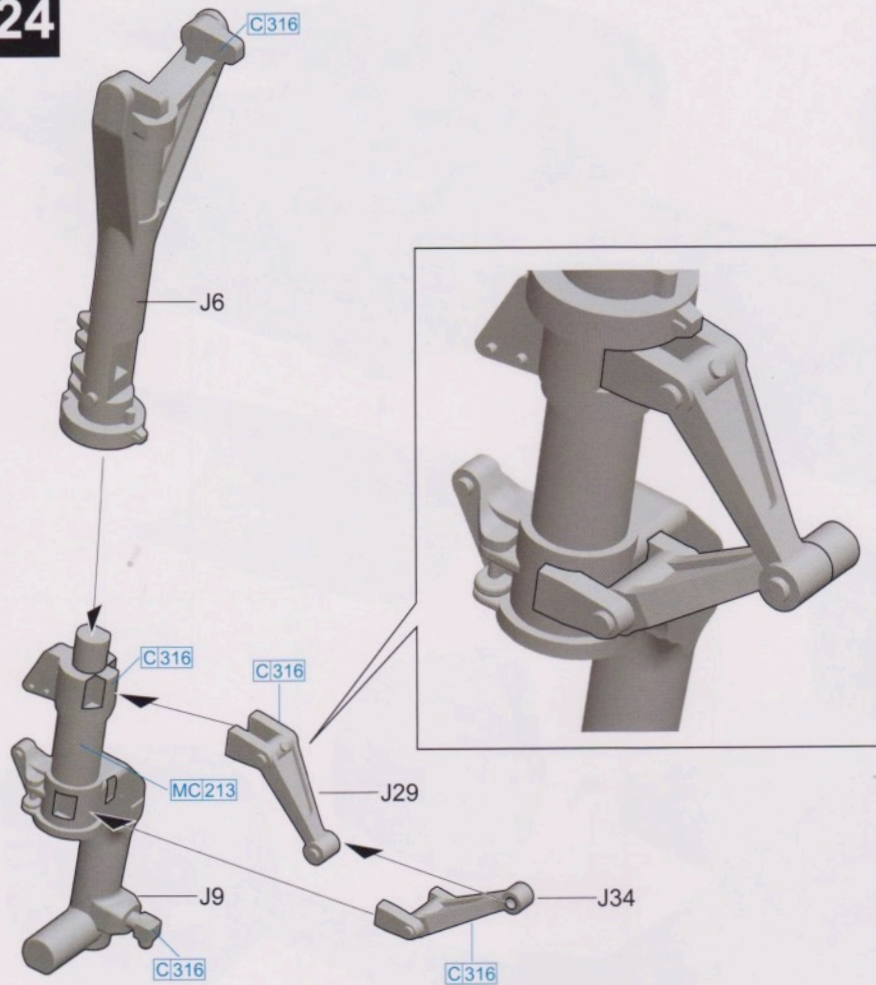

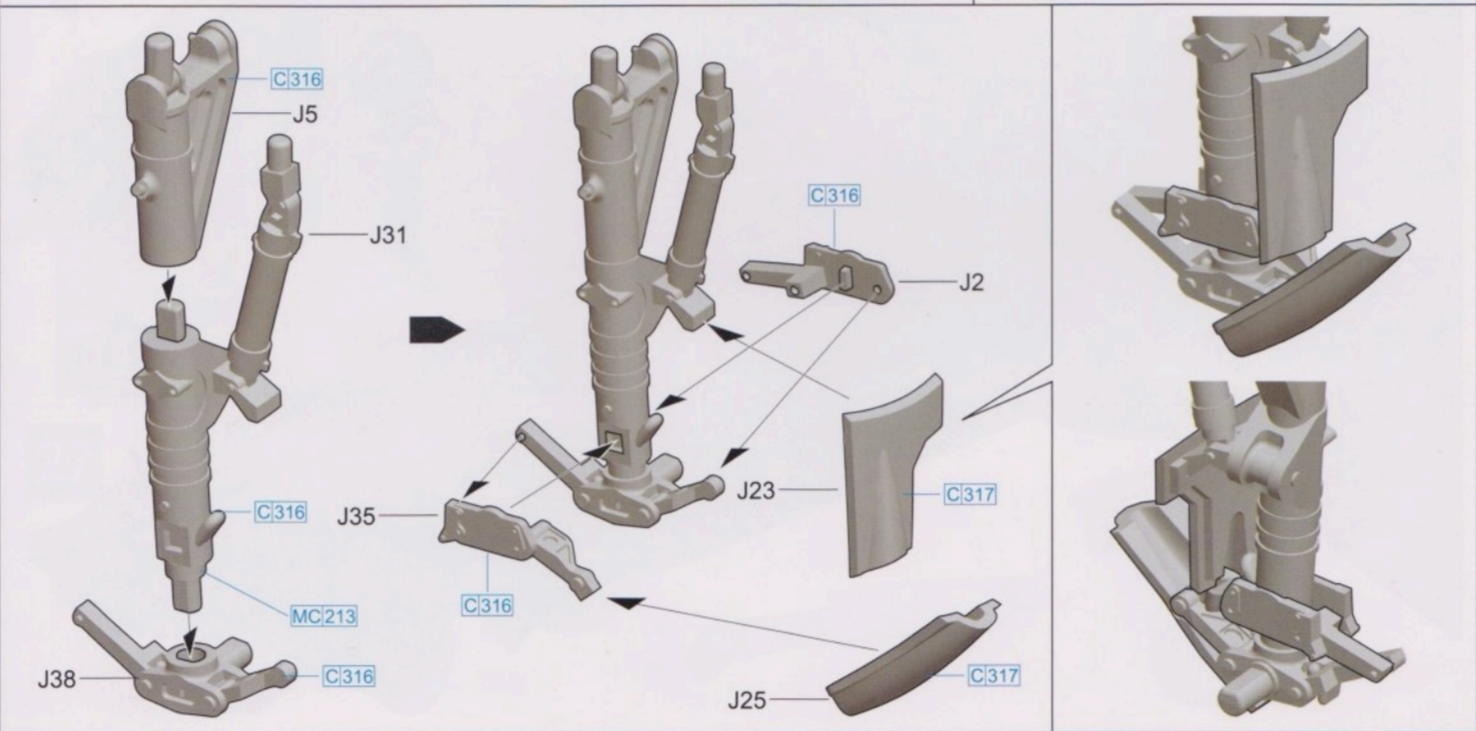
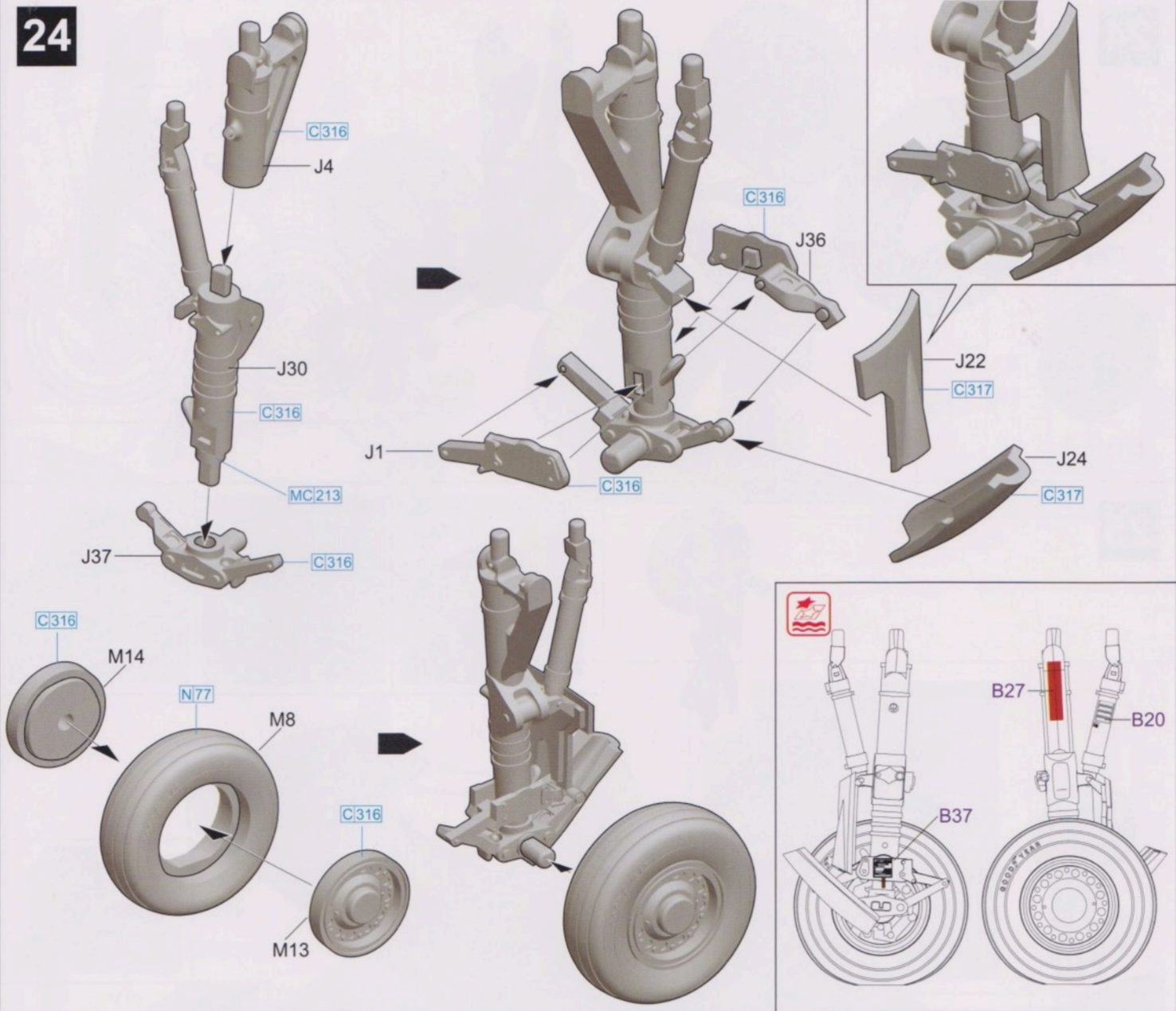

24

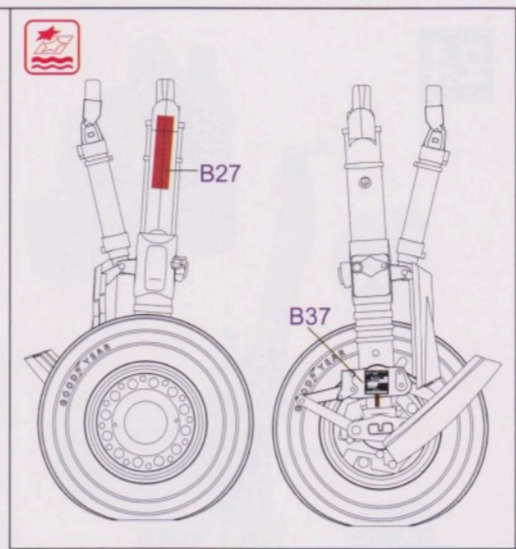
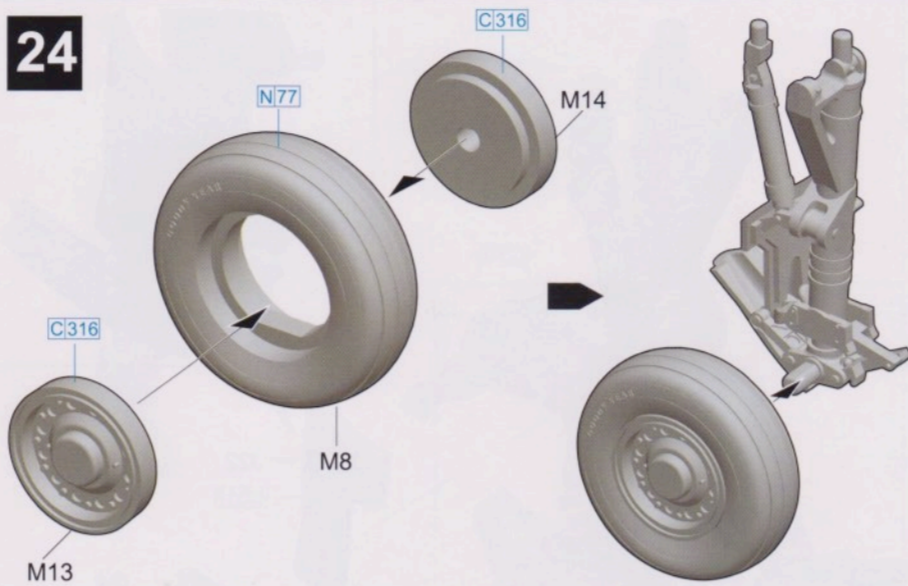

25

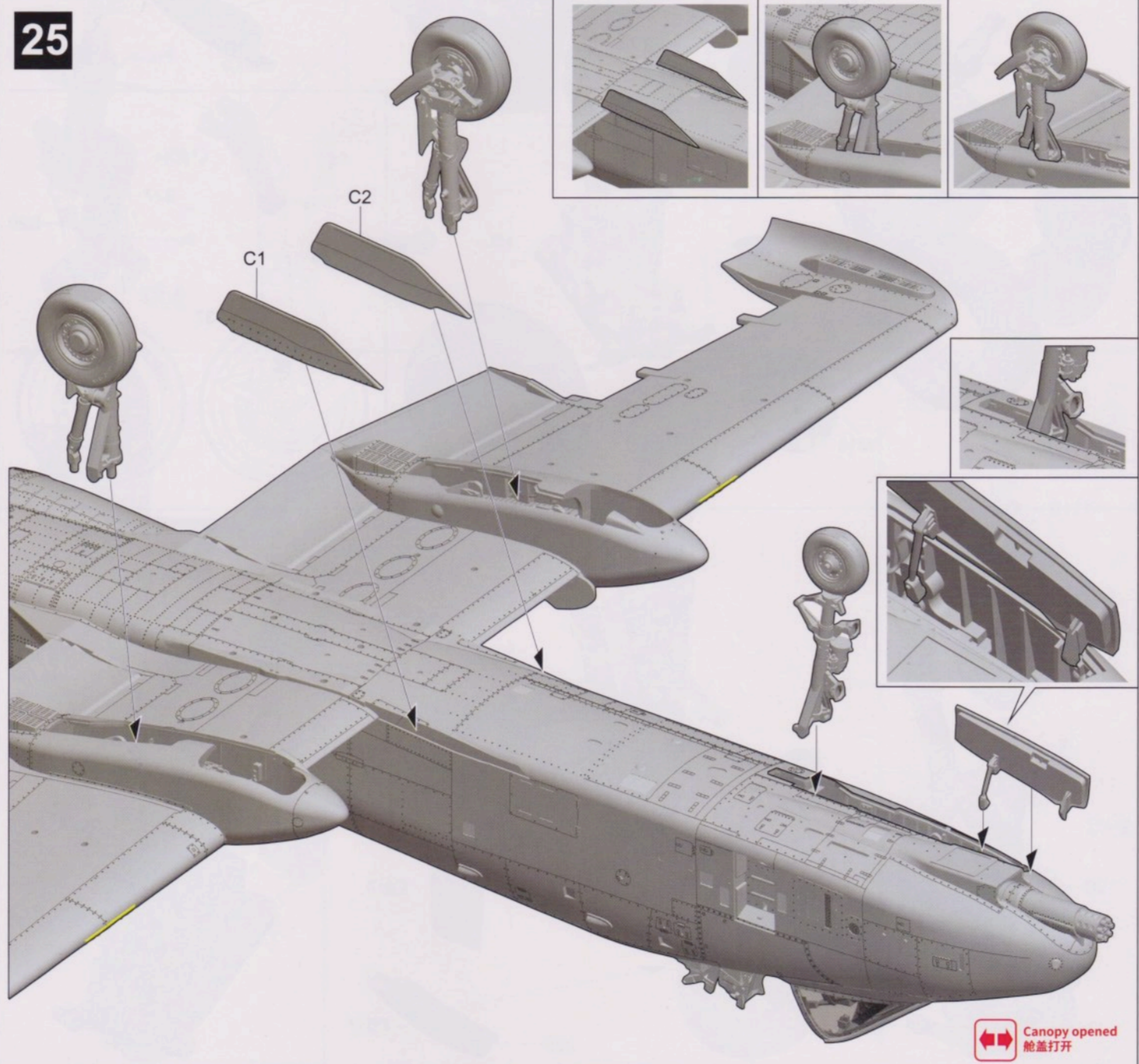

Canopy opened
舱盖打开

26

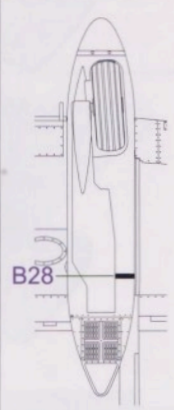
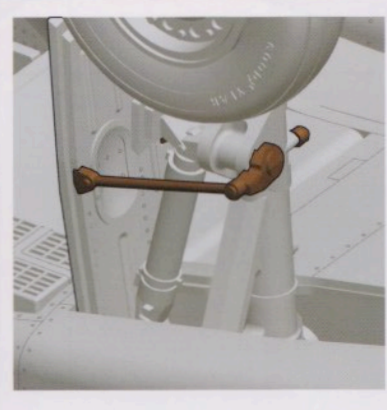
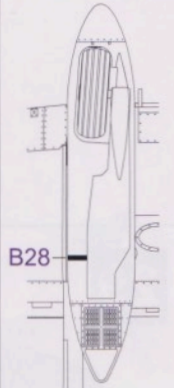
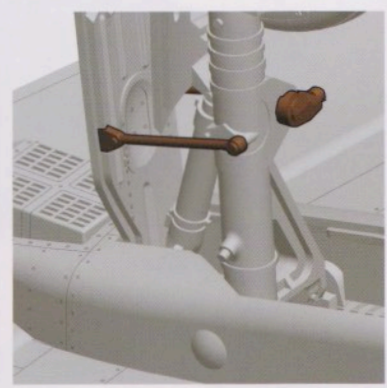
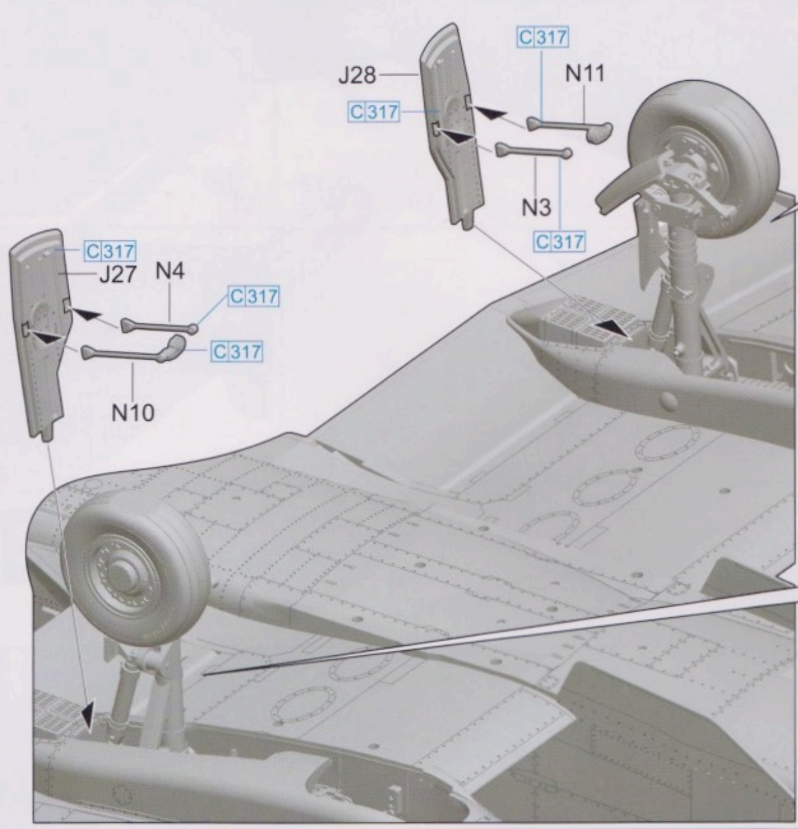
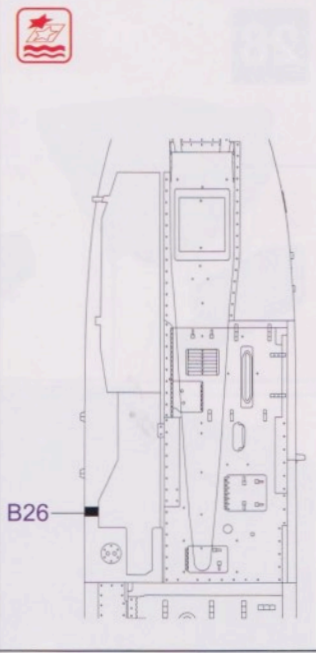
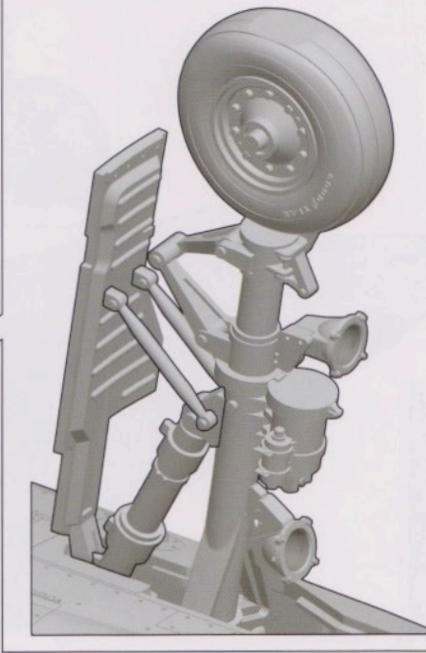
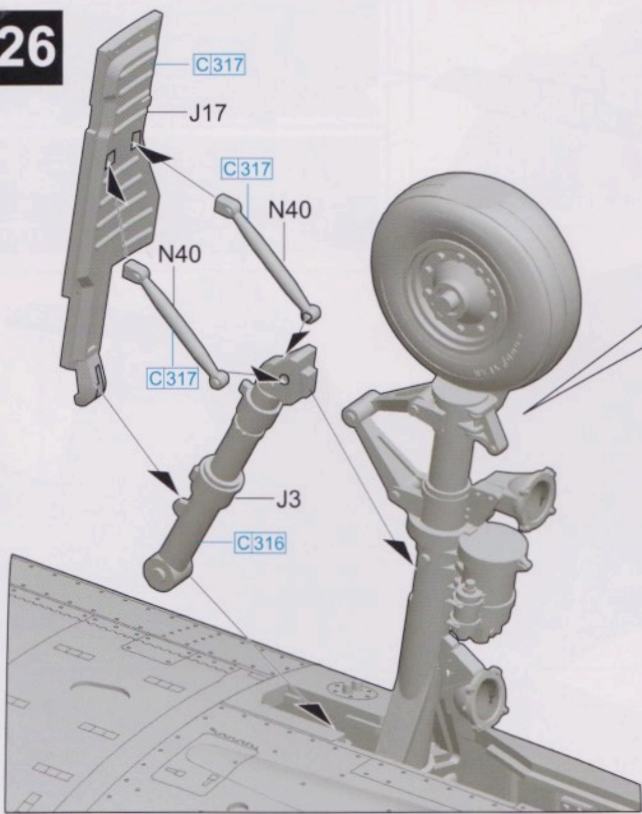

27

Canopy closed
舱盖关闭

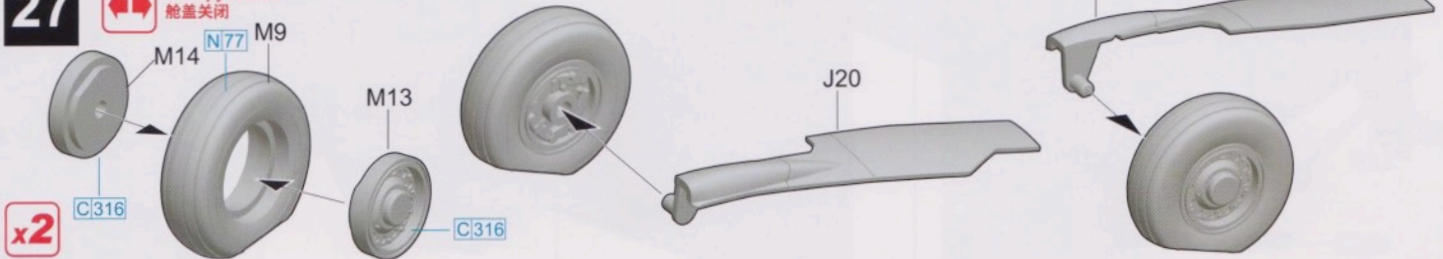

28

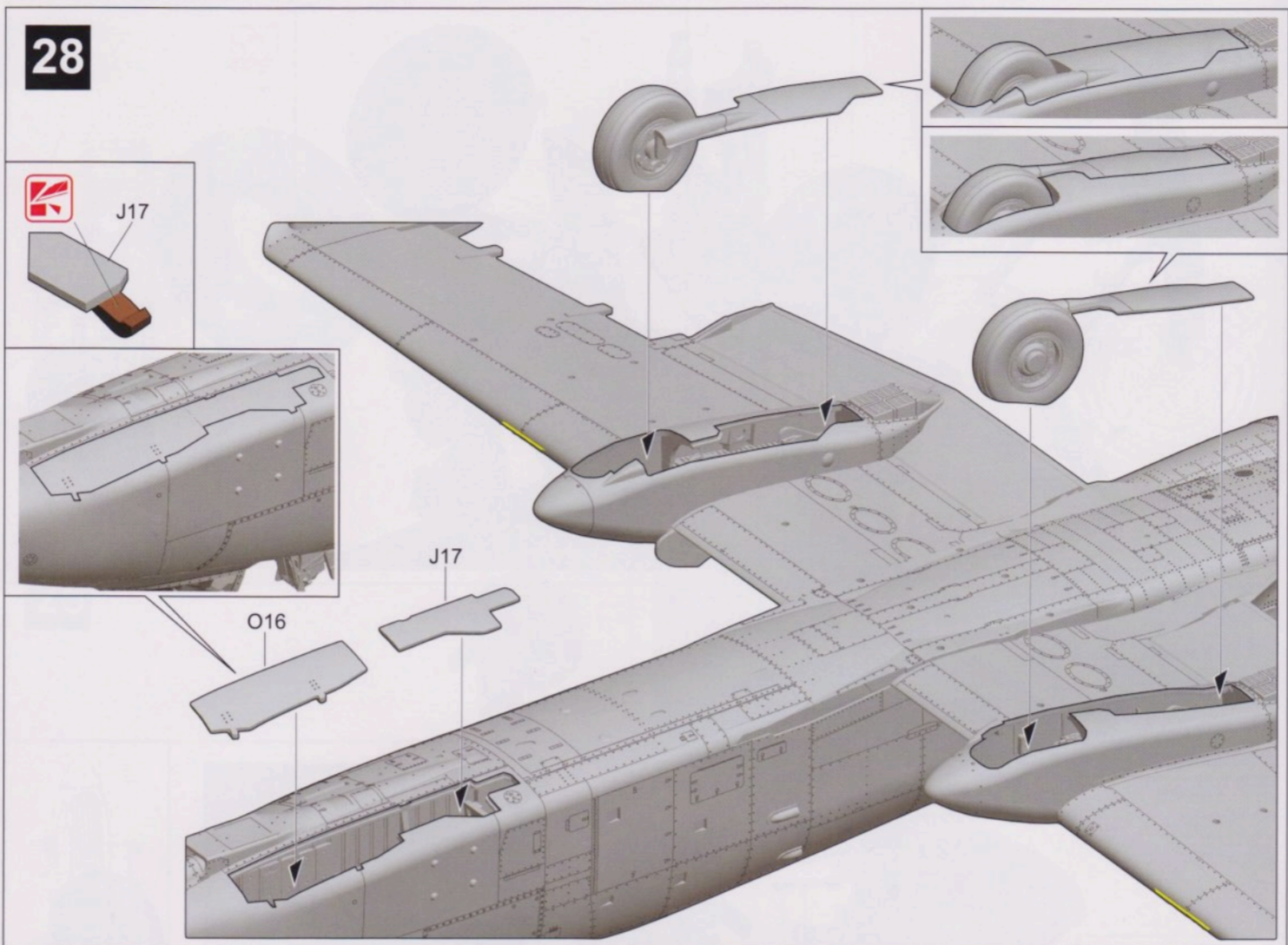

29

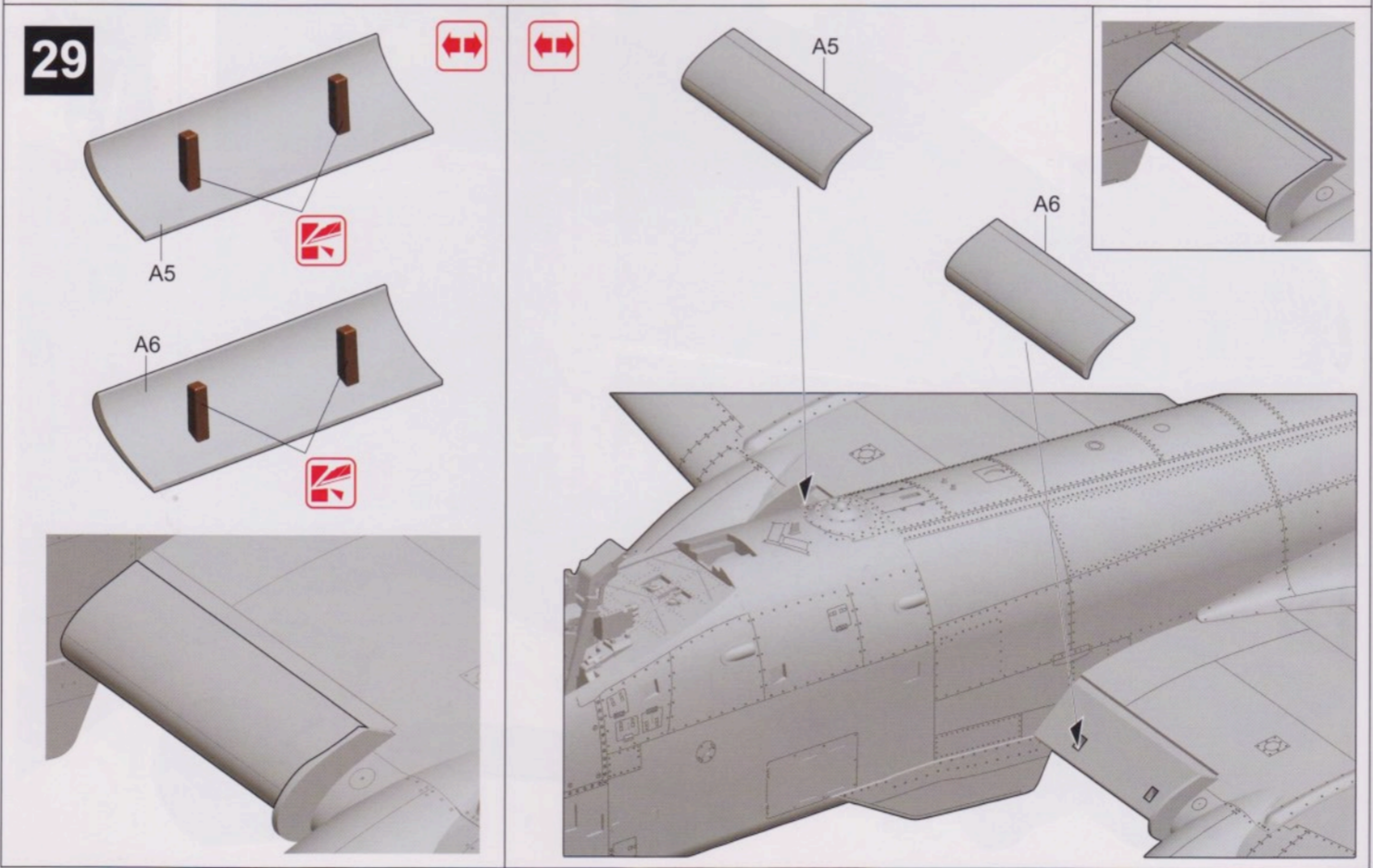

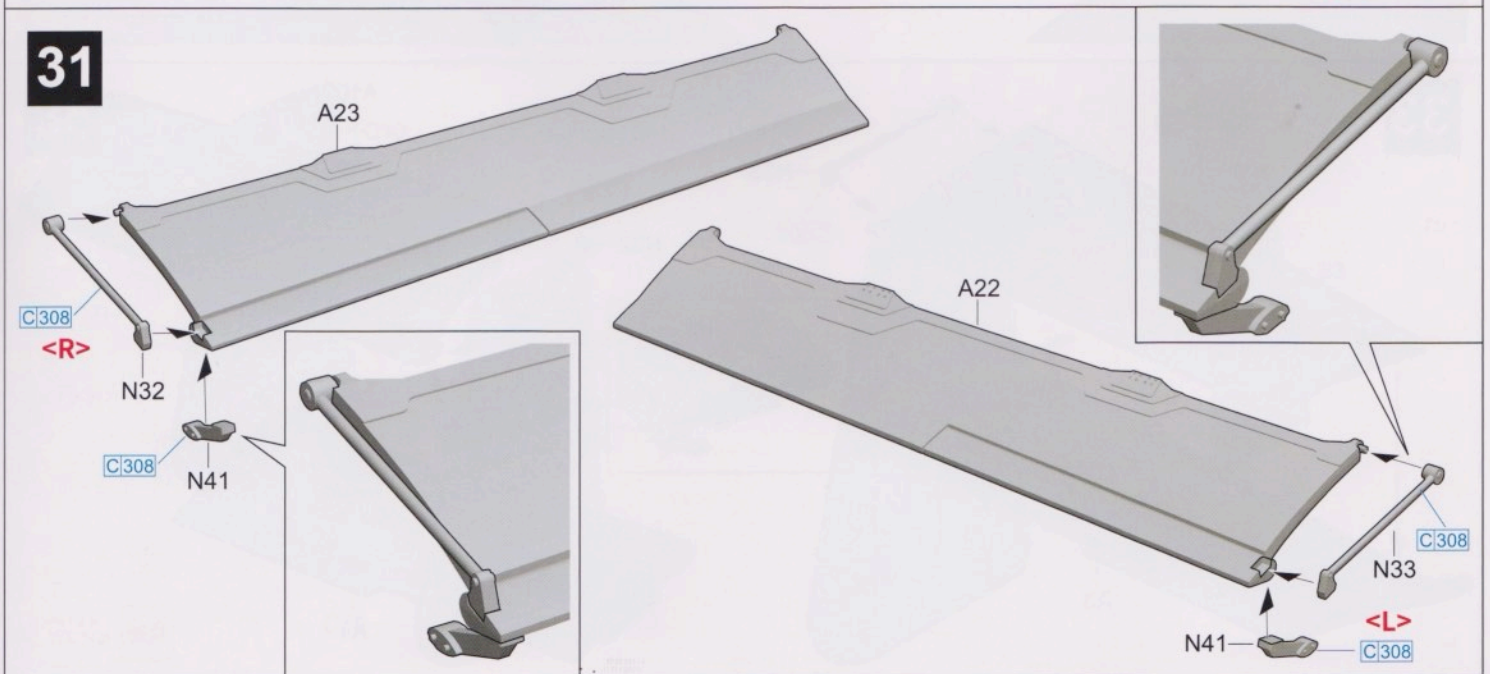
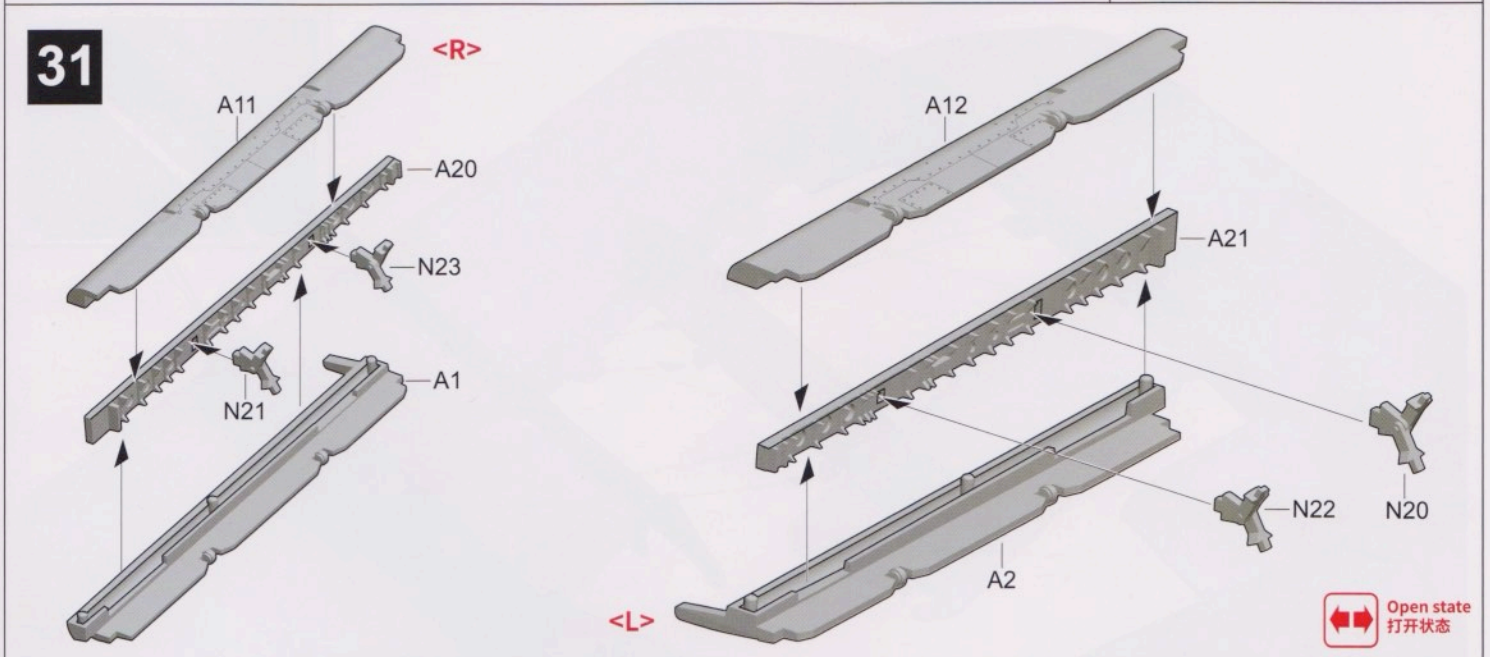
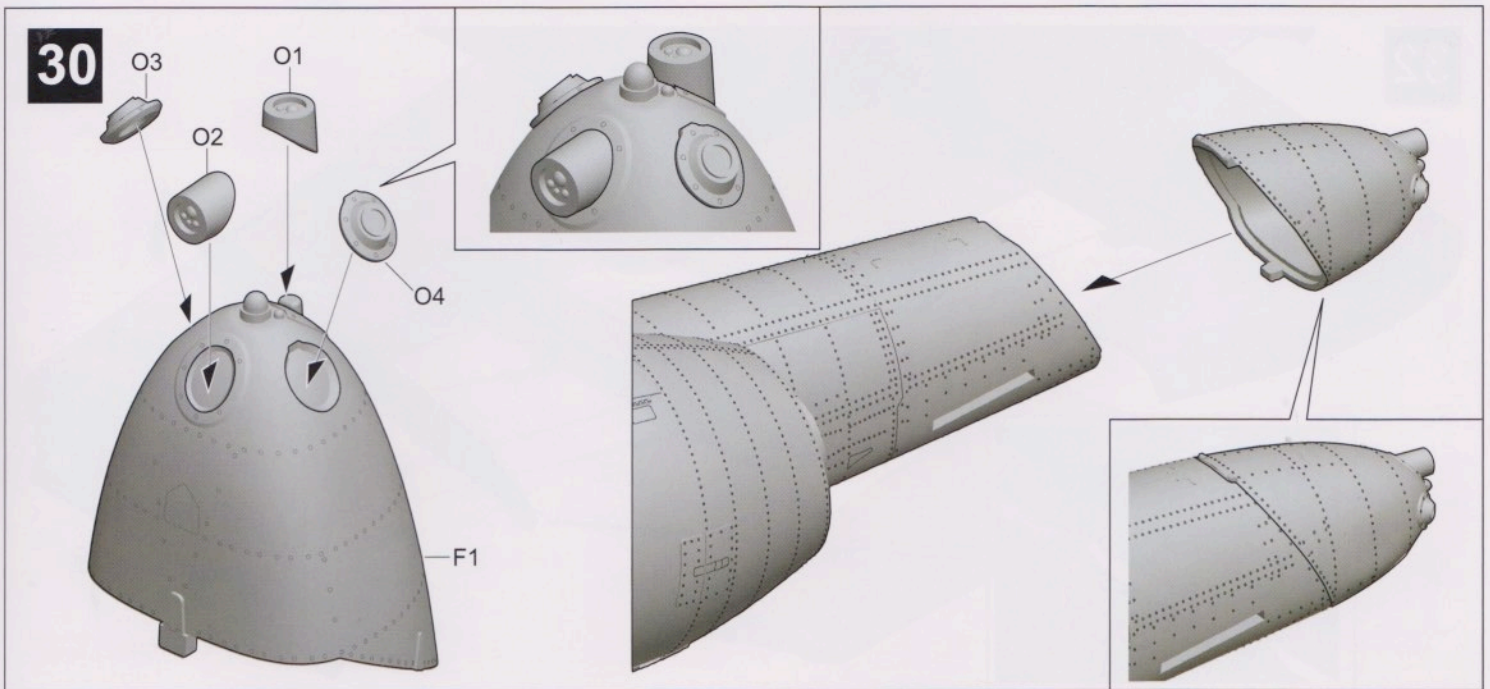

32

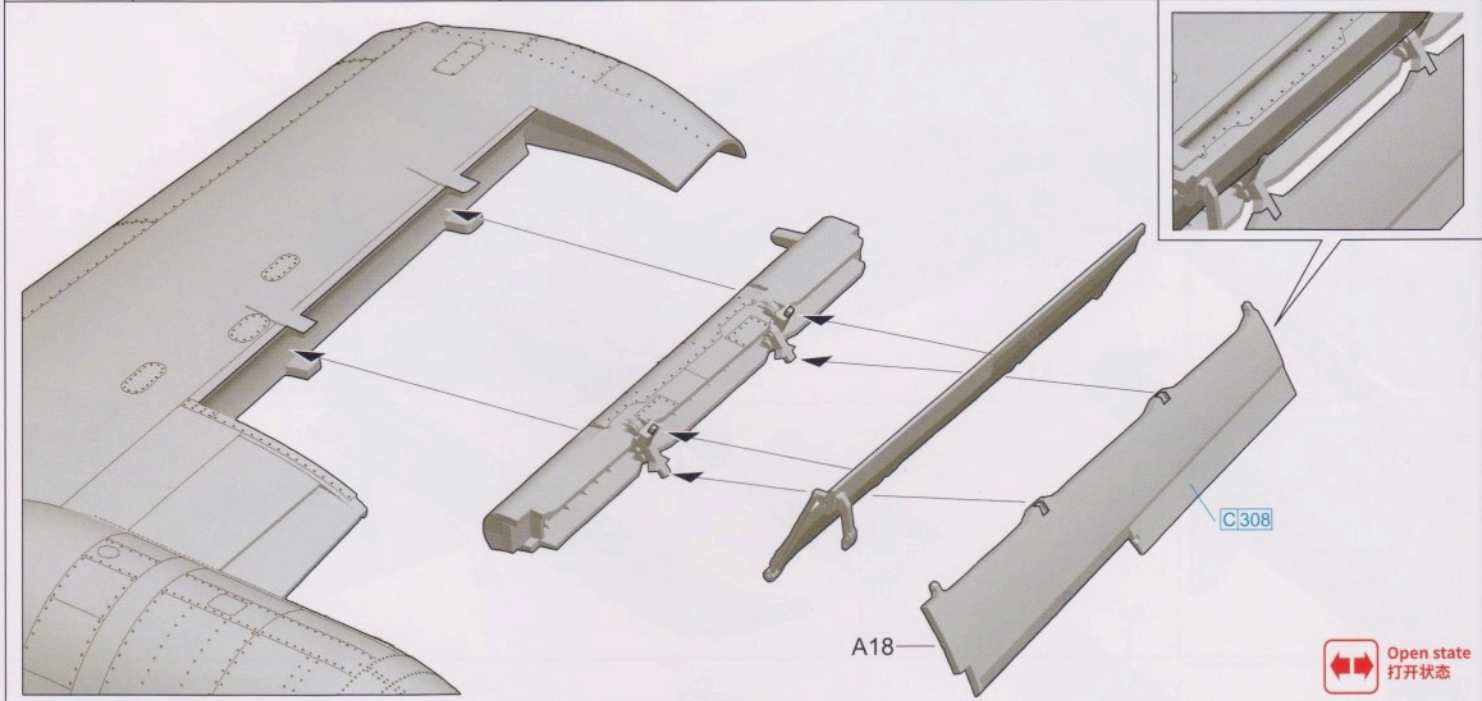
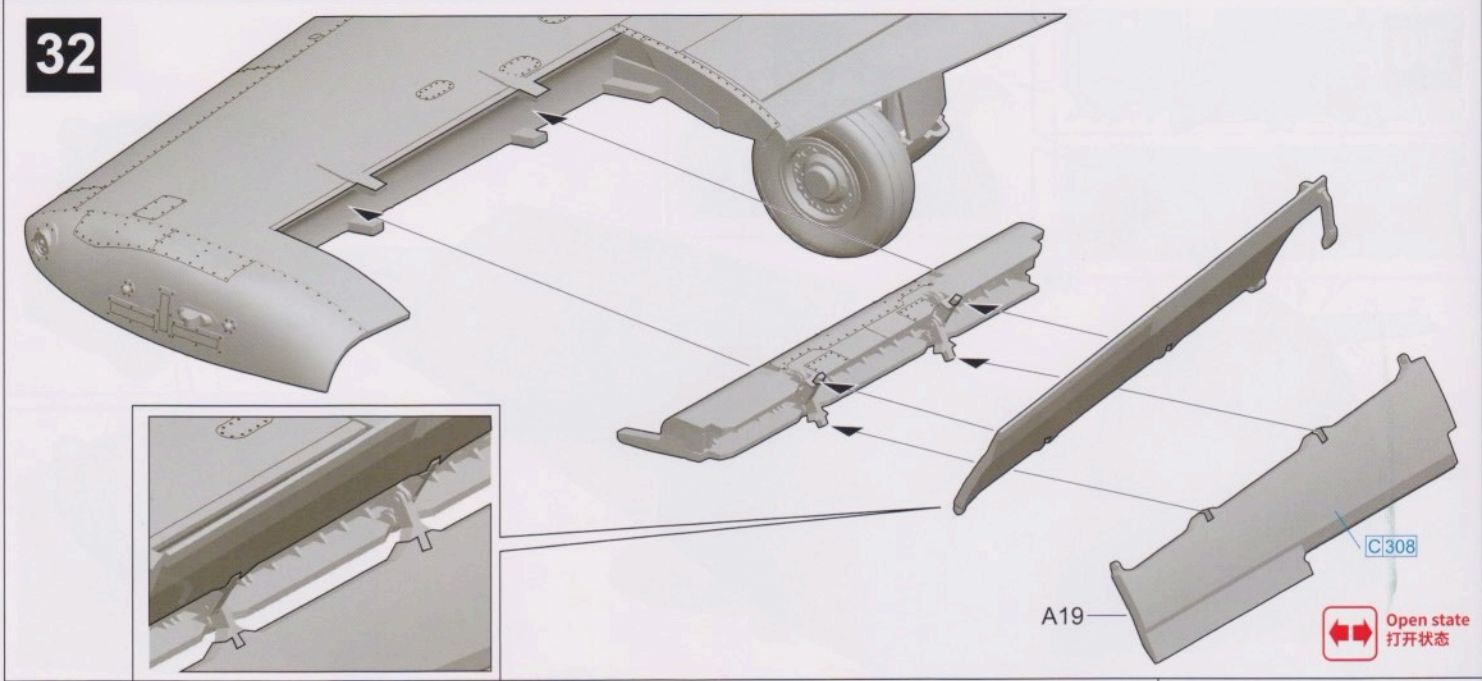

33

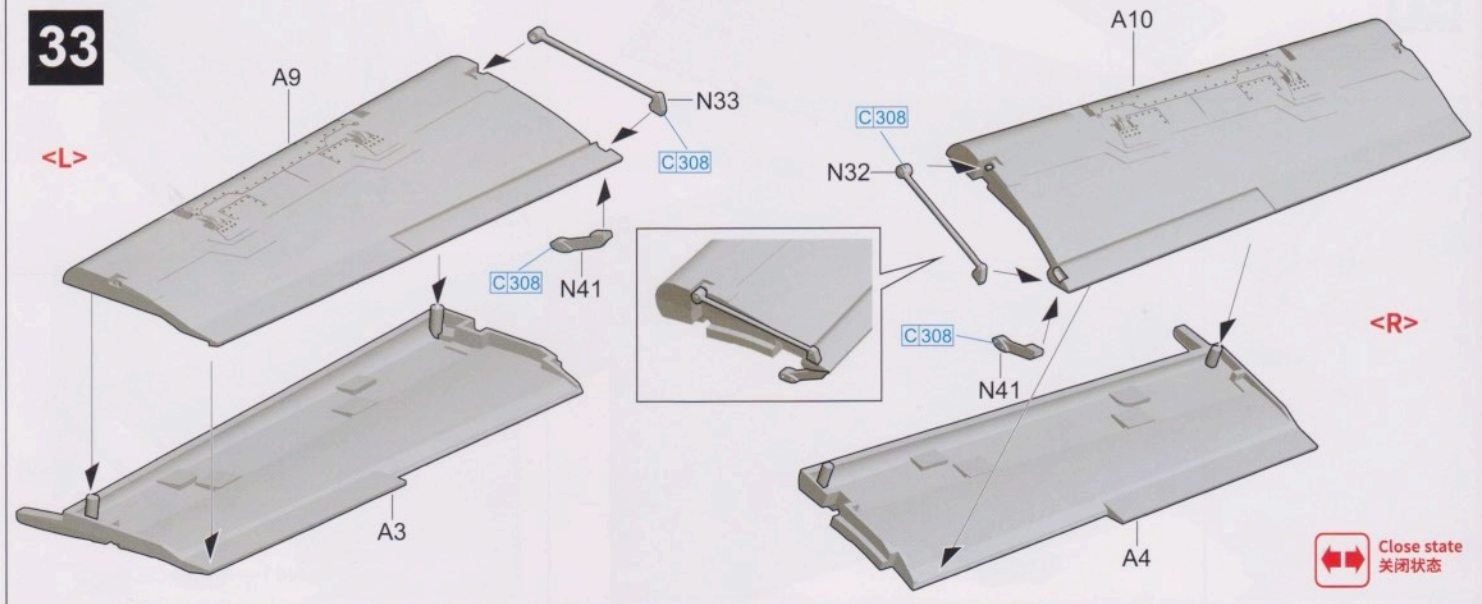

34

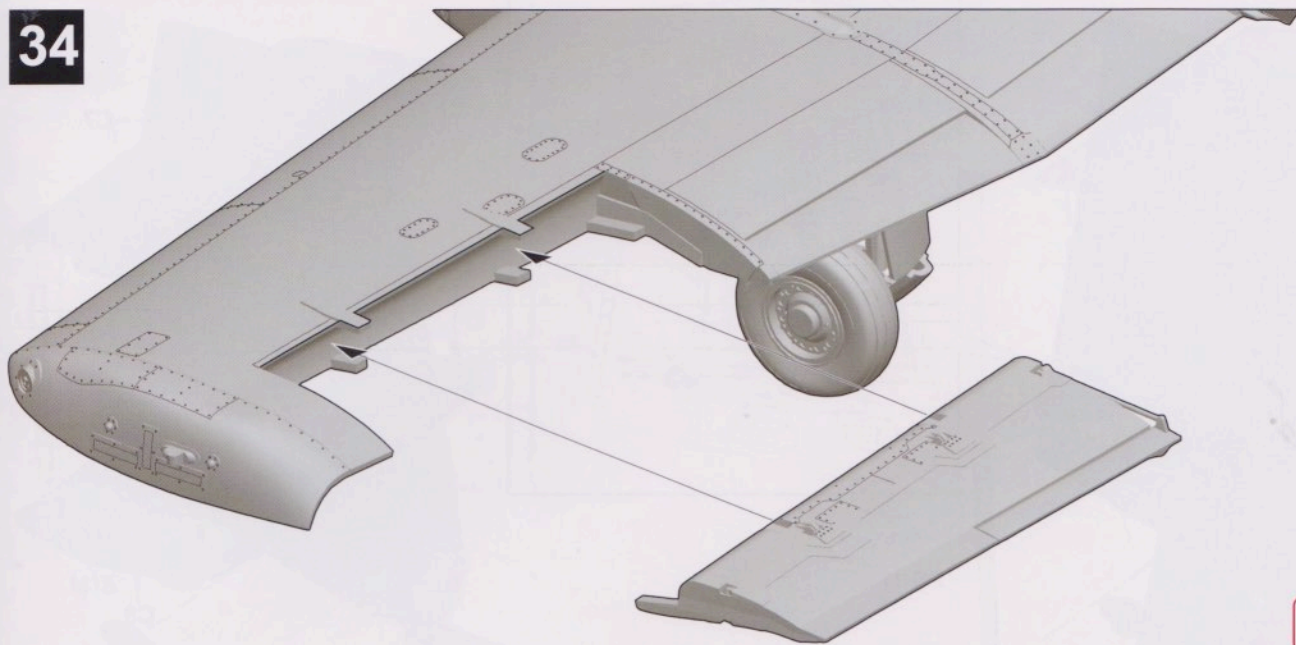

Close state
关闭状态

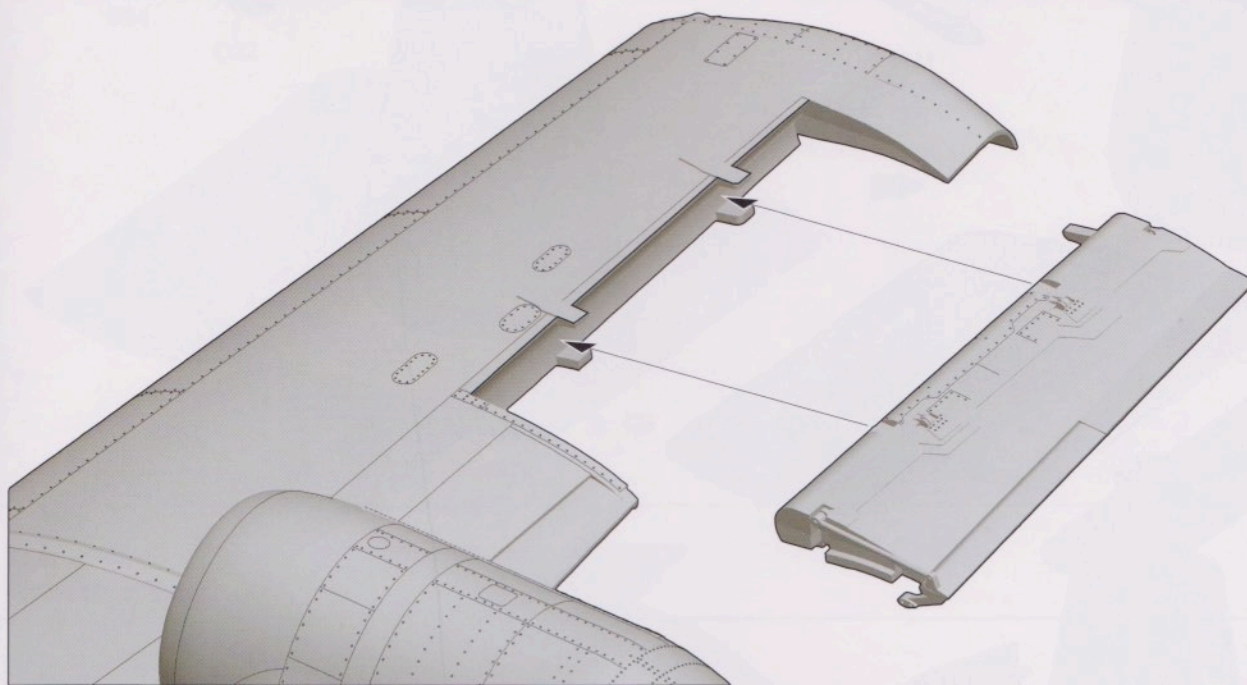

Close state
关闭状态

35

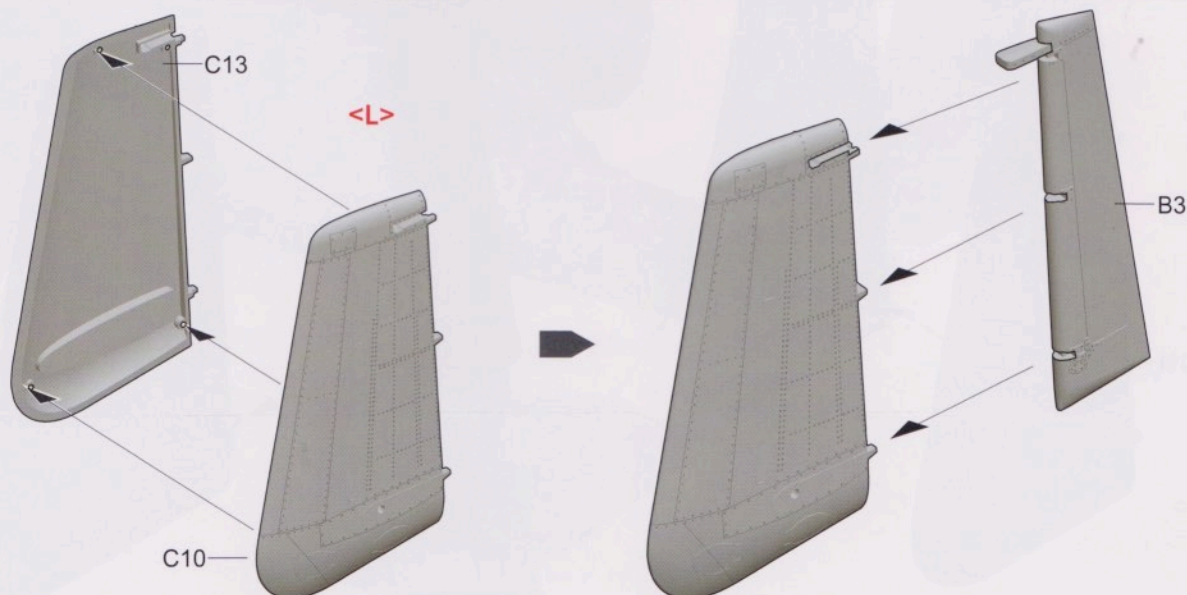

35

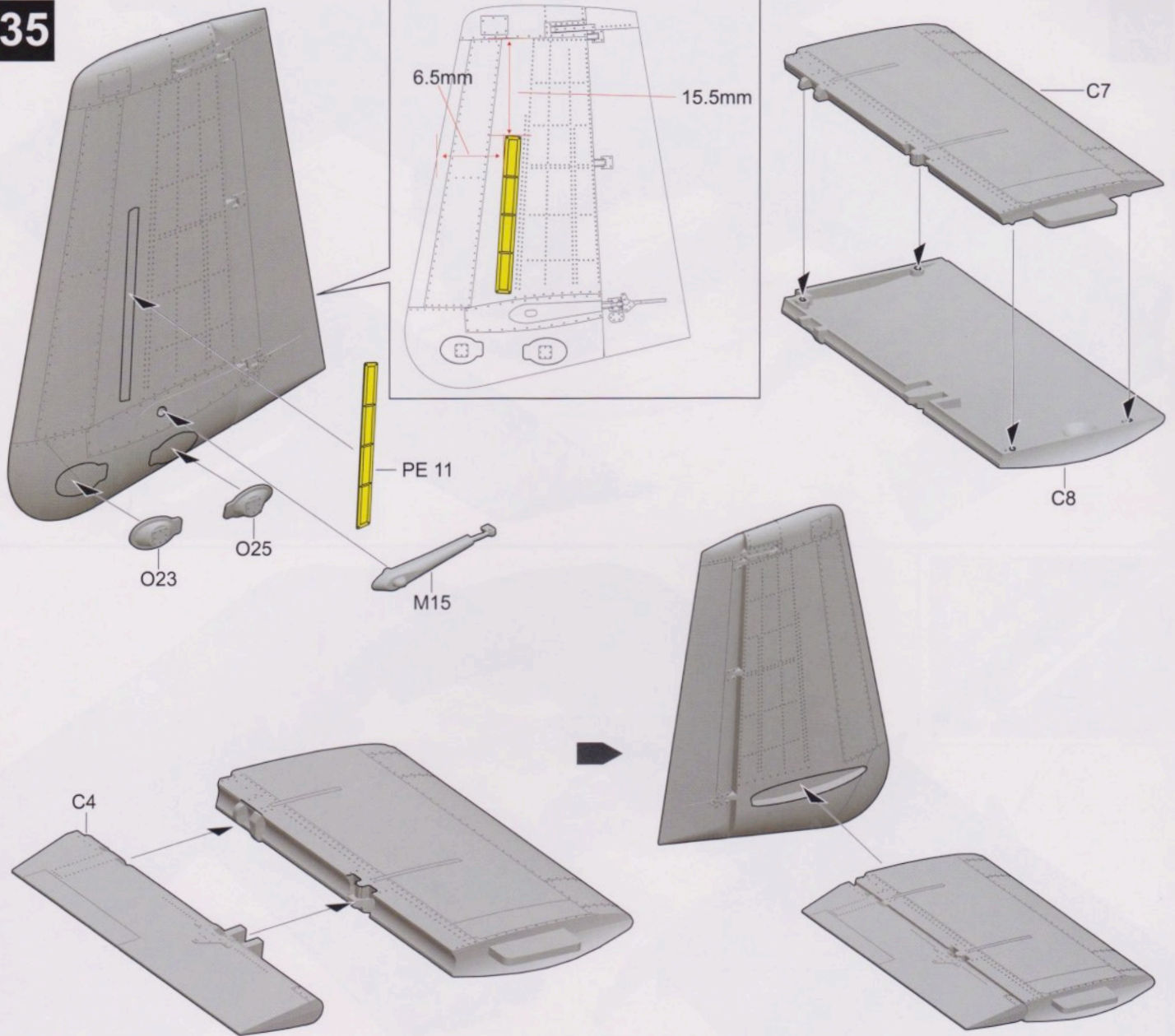

36

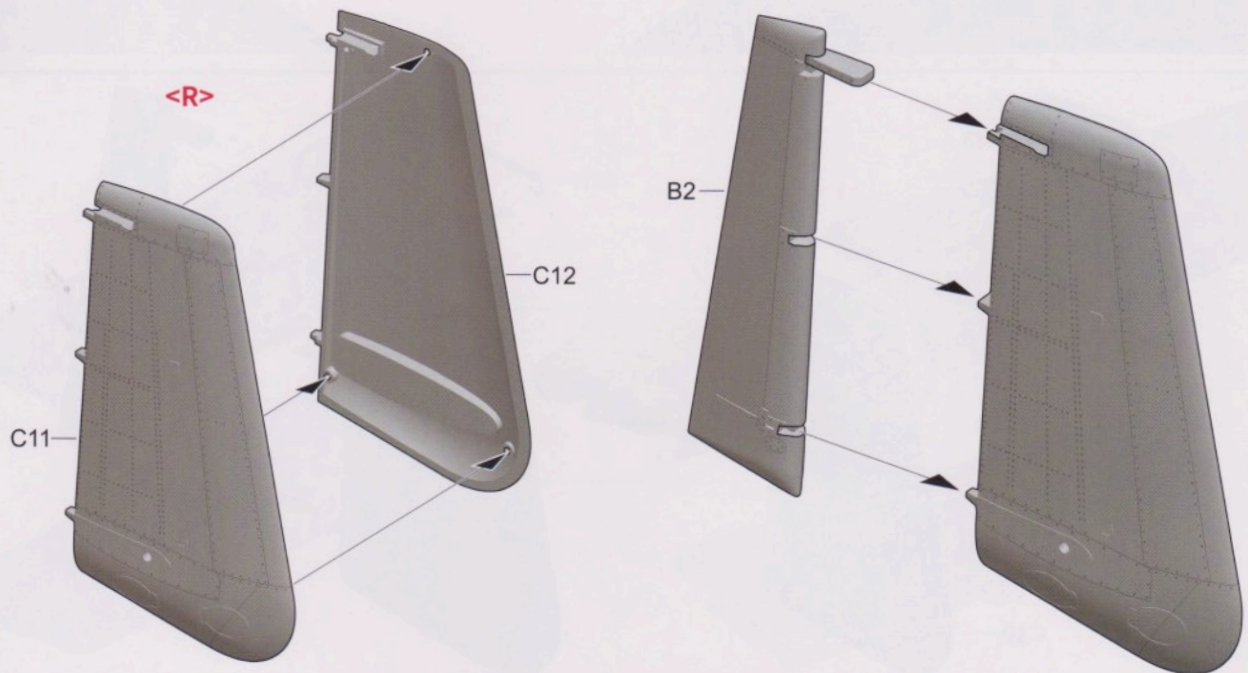

36

PE 10

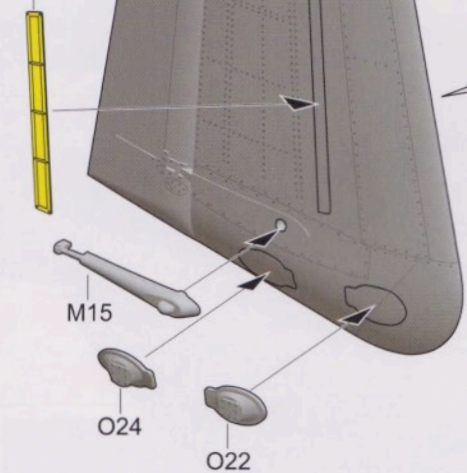

15.5mm

6.5mm

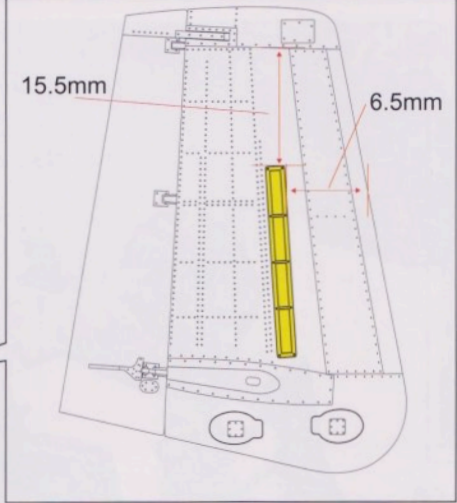

C6

C9

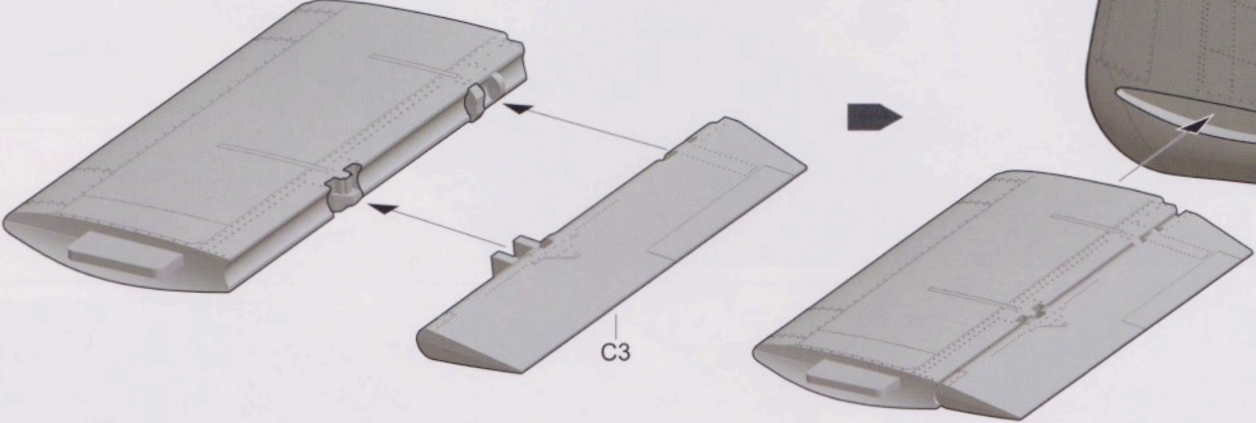
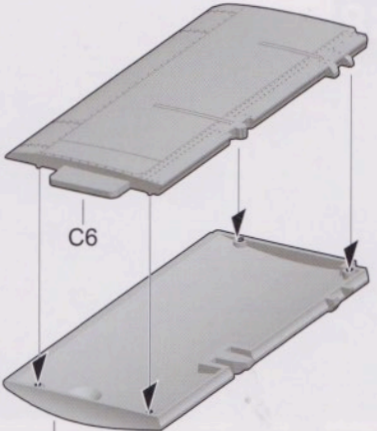

37

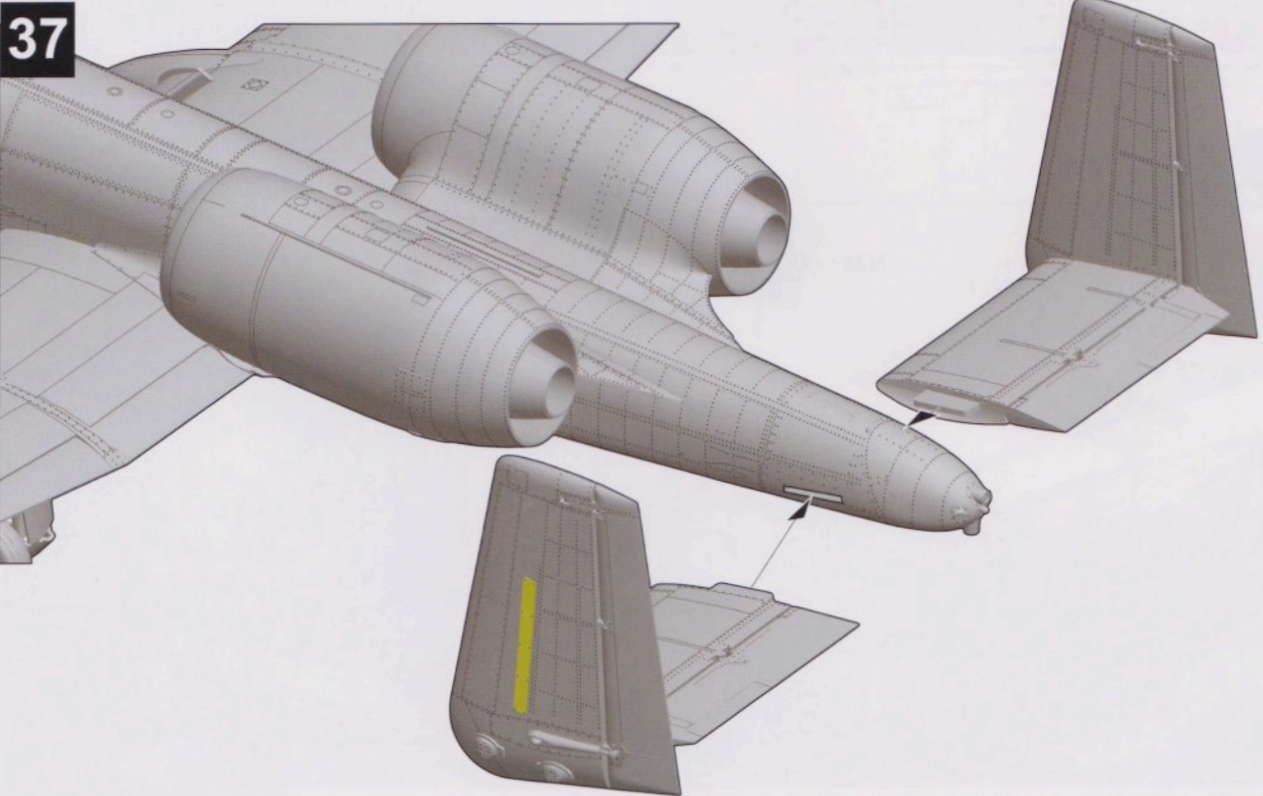

38

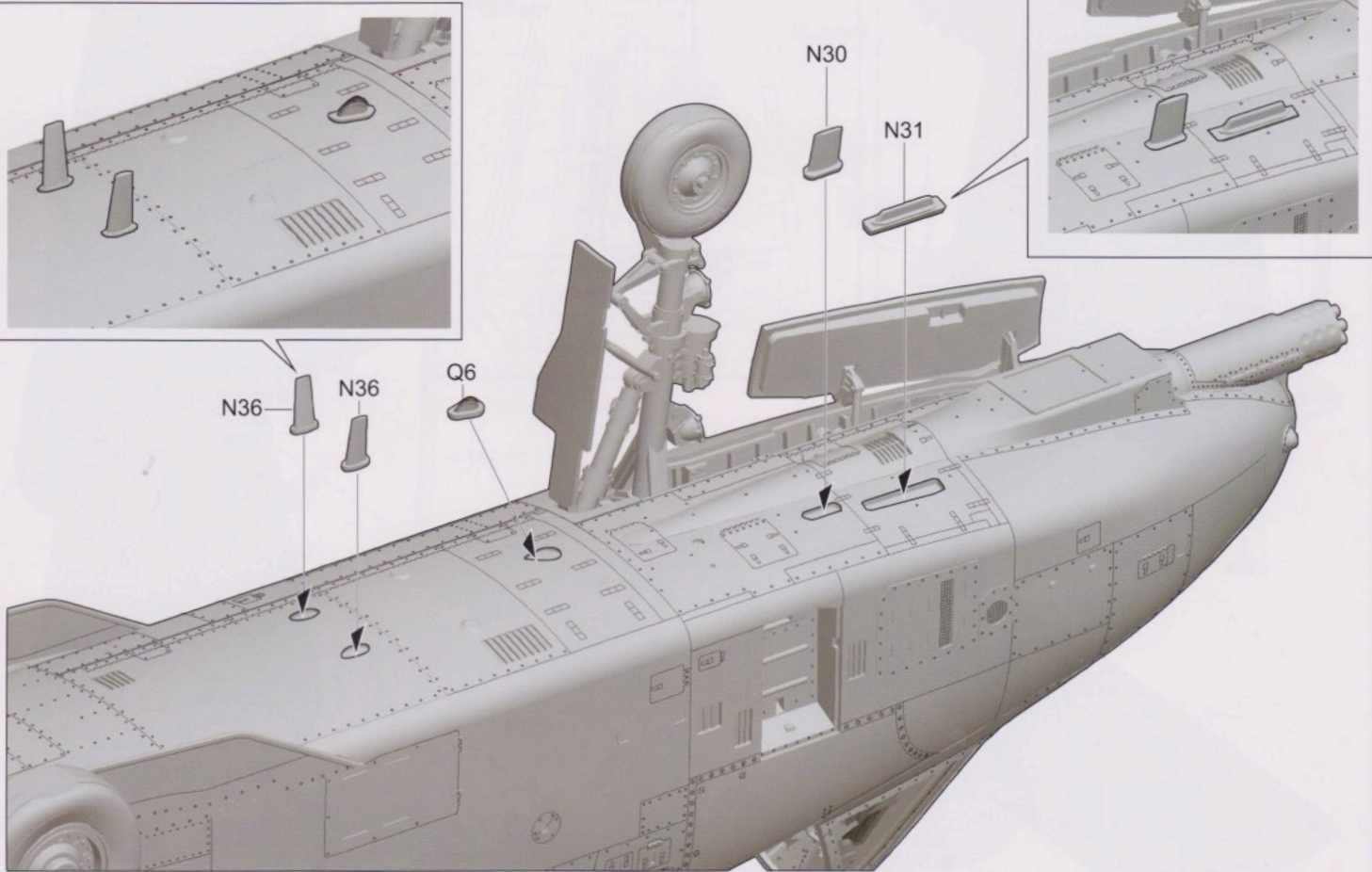

38

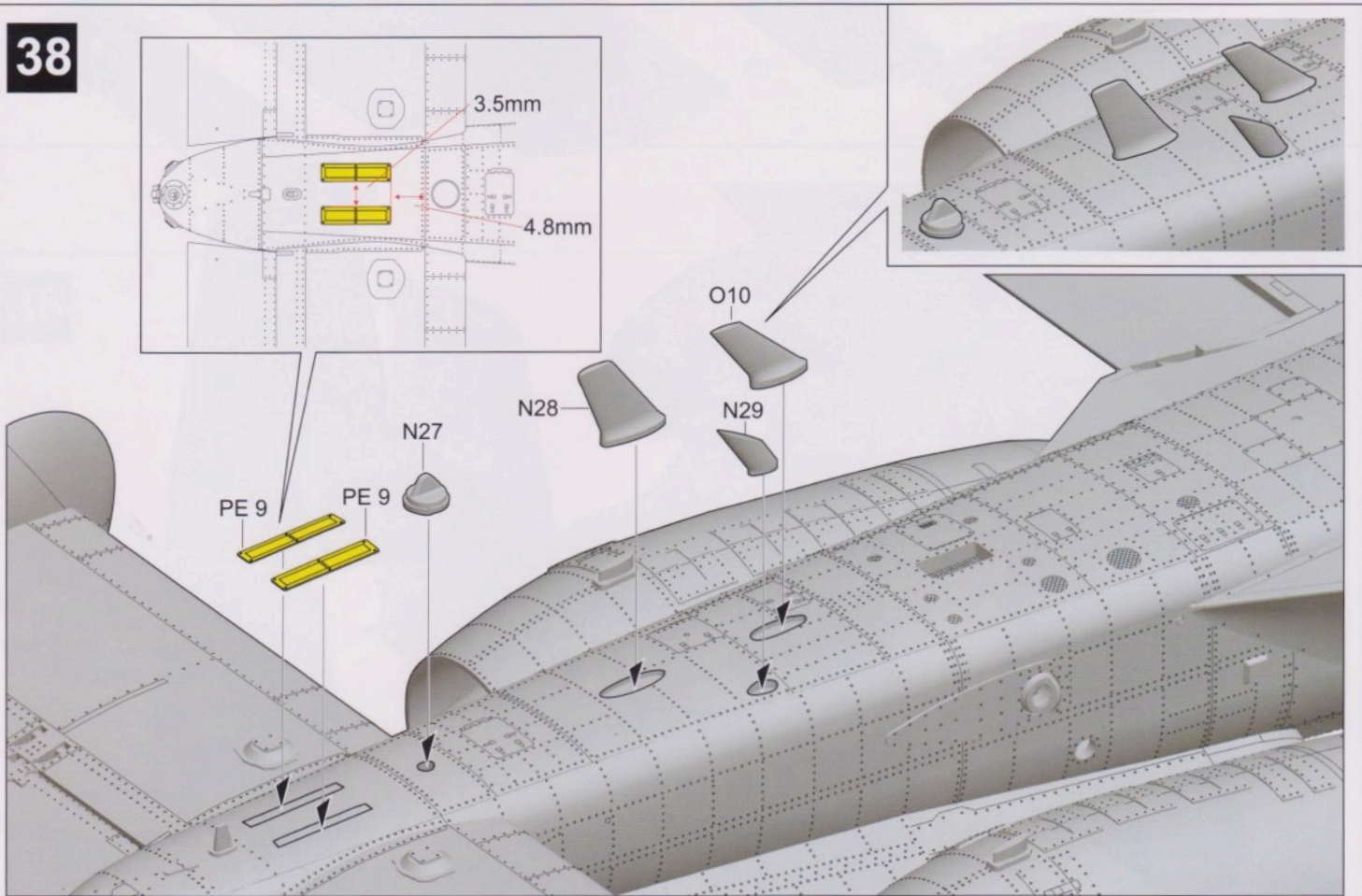

39

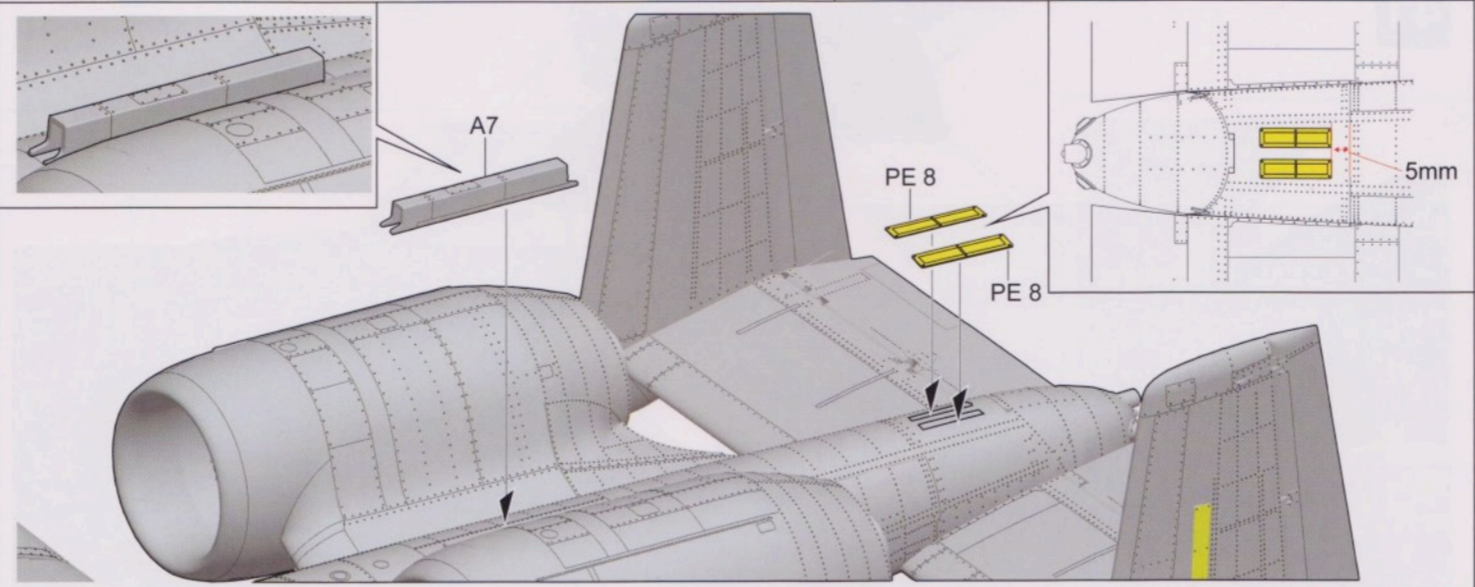
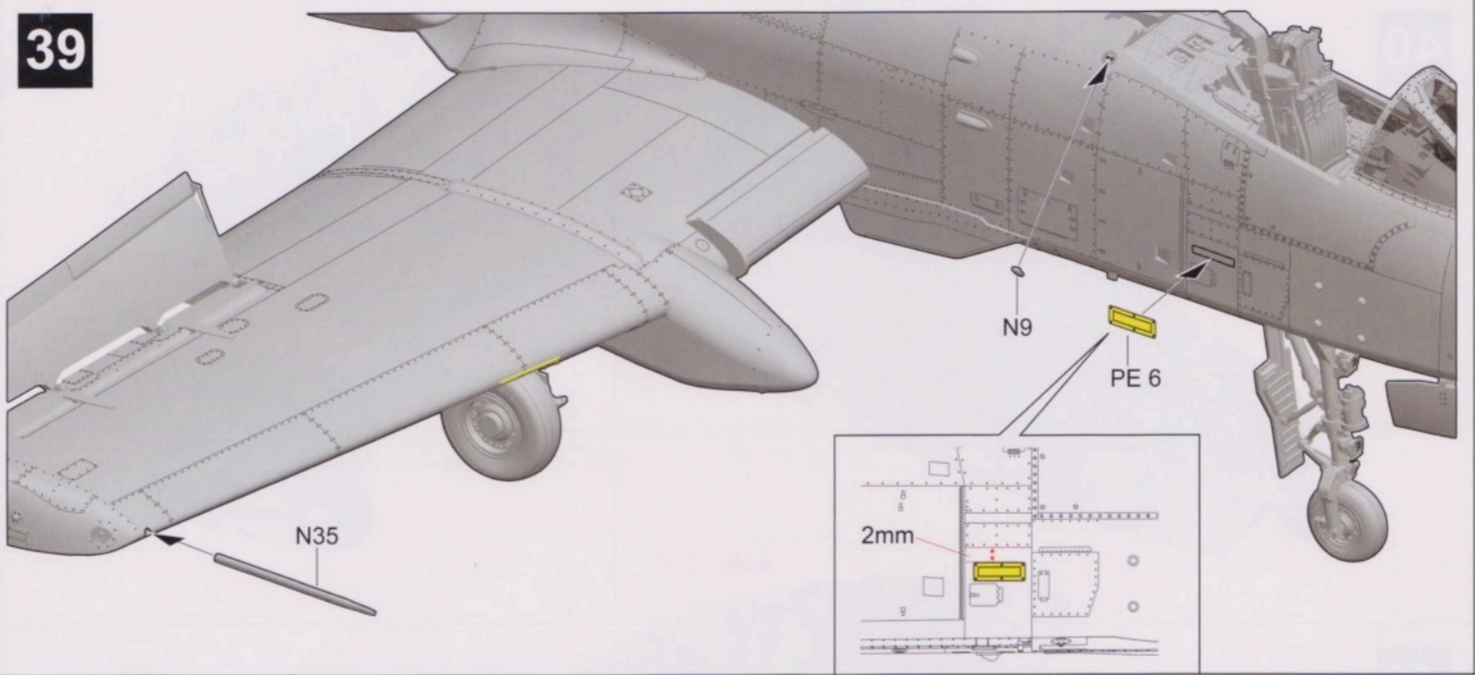

40

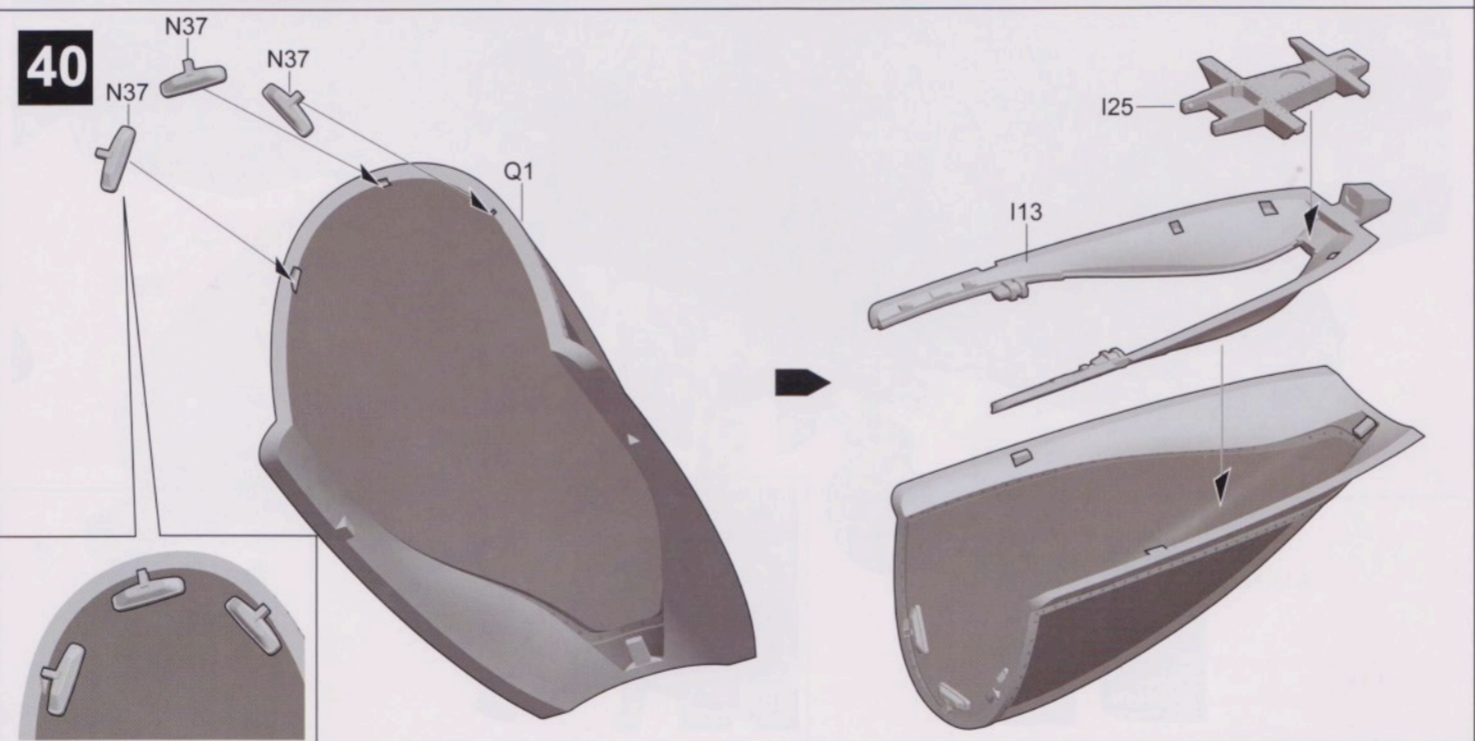

40

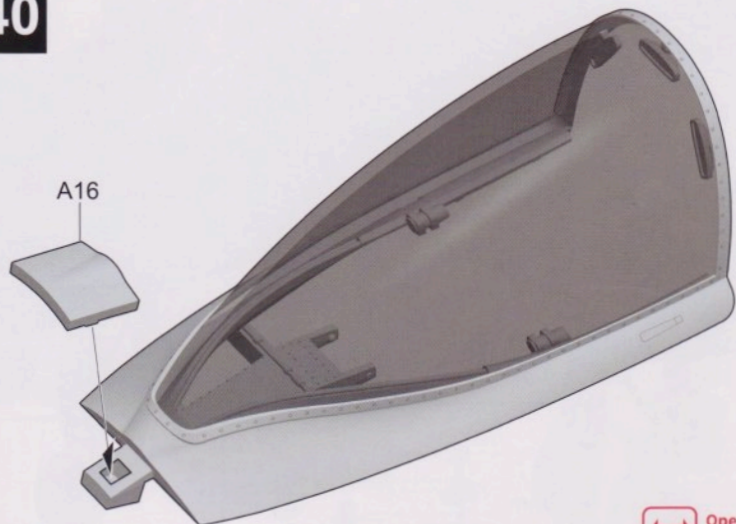

Open state
打开状态

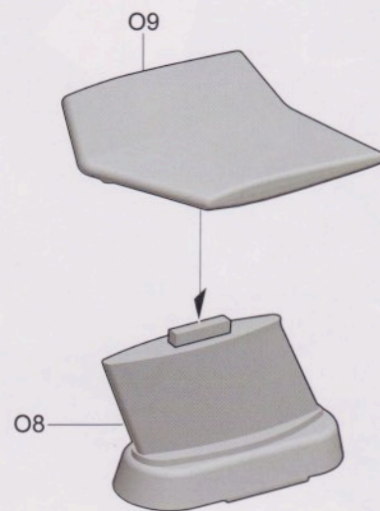

41

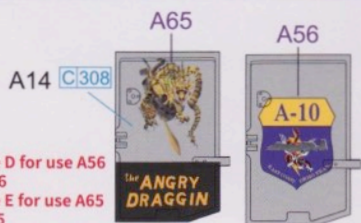
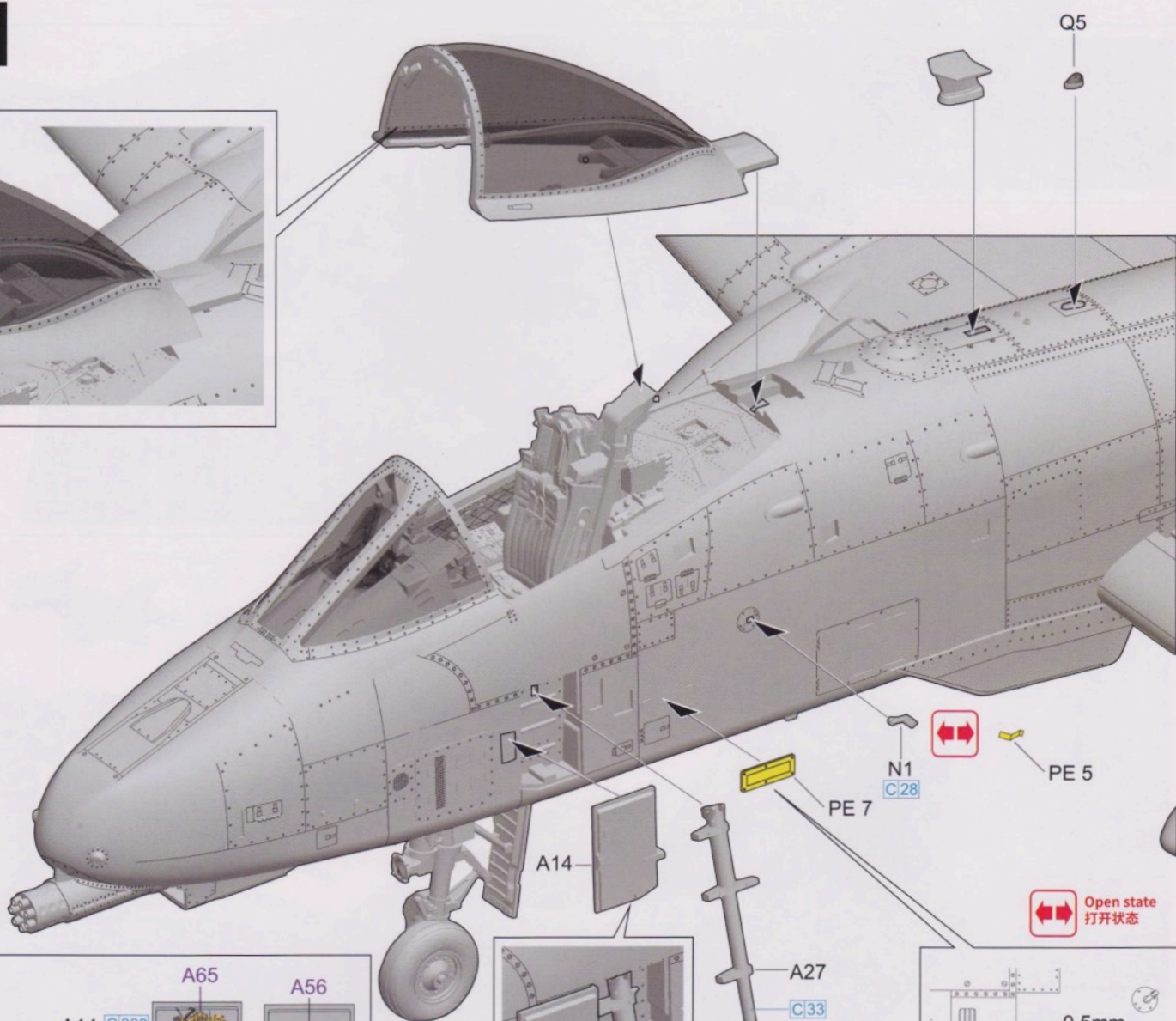
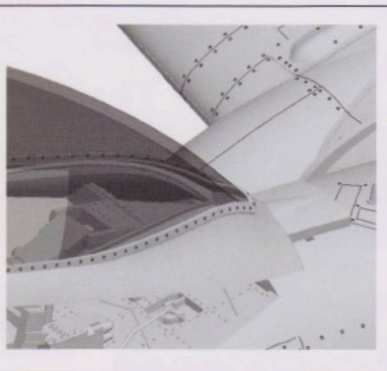

Painting scheme D for use A56
涂装D使用水贴A56
Painting scheme E for use A65
涂装E使用水贴A65

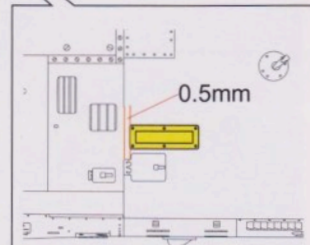
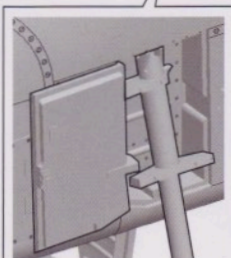

42

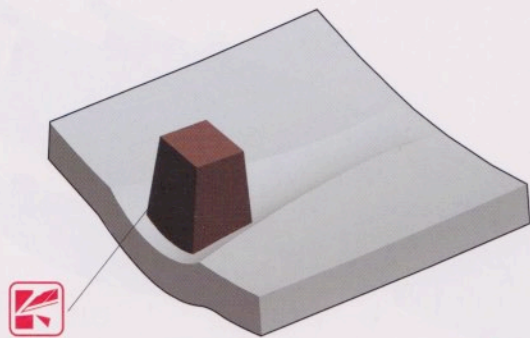

A16



Close state
关闭状态

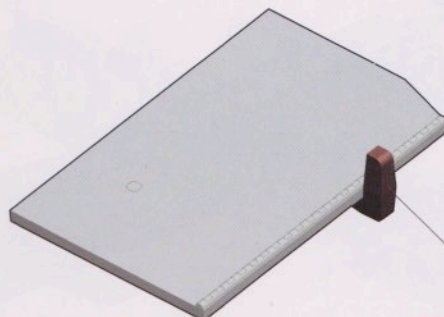

A14



Close state
关闭状态

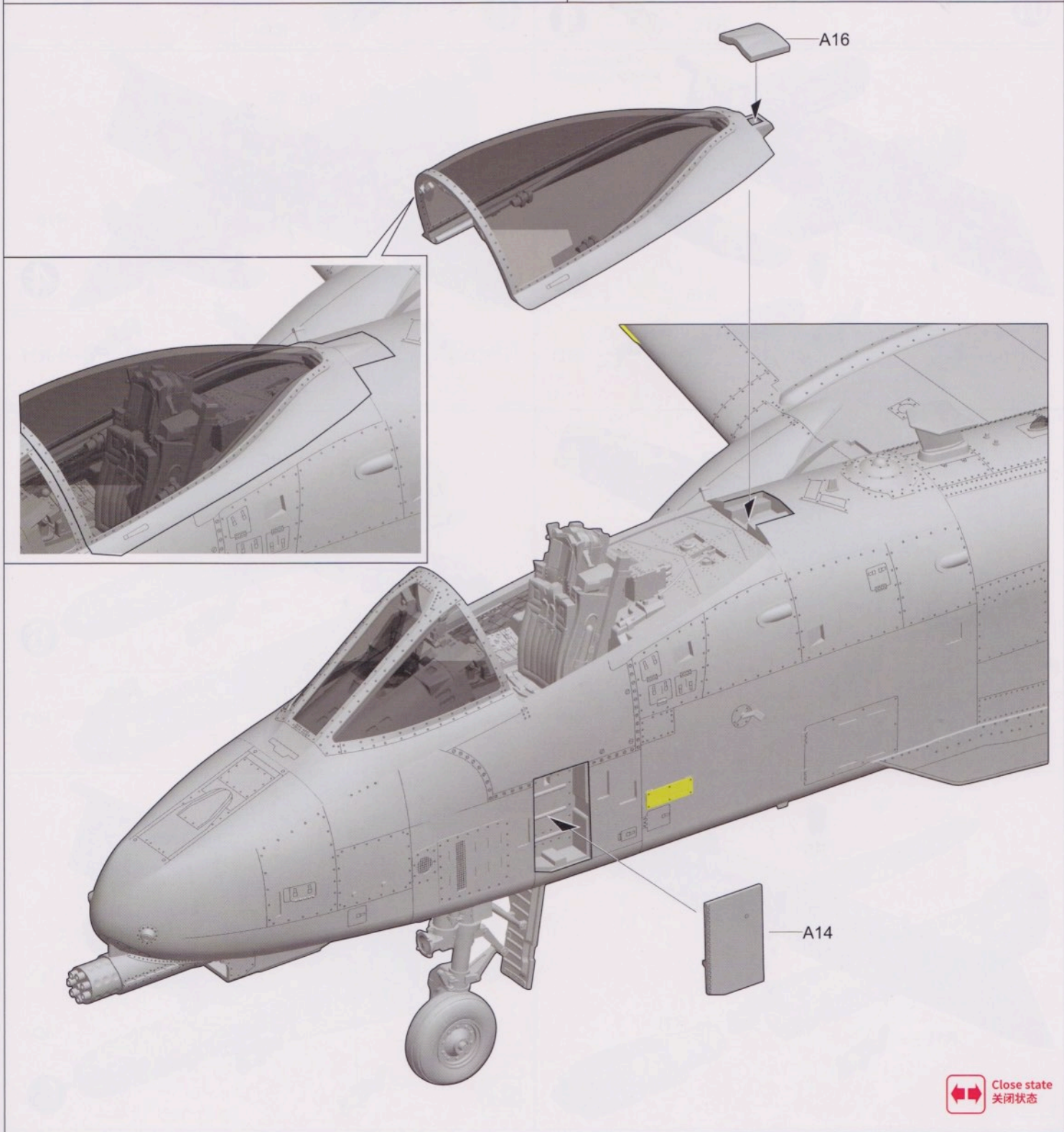

A16

A14



Close state
关闭状态

43

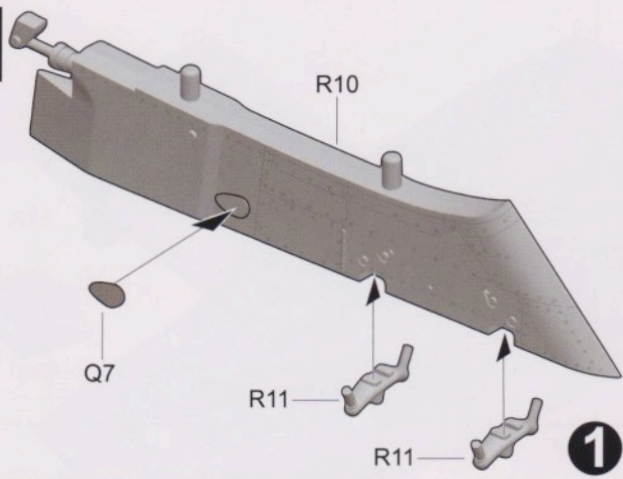

1

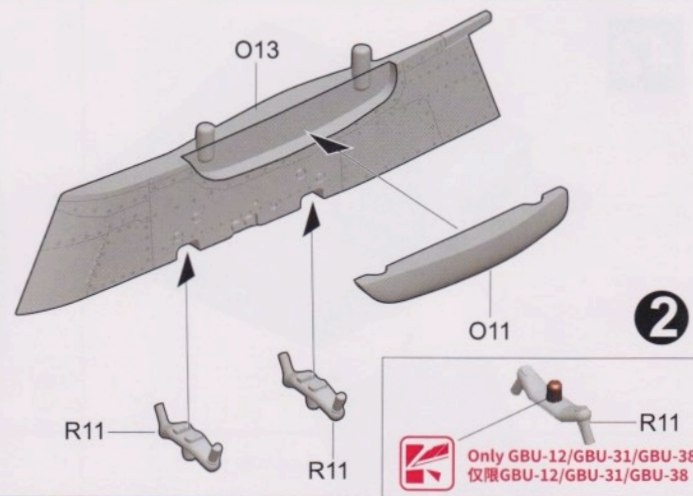

2

 Only GBU-12/GBU-31/GBU-38
仅限GBU-12/GBU-31/GBU-38

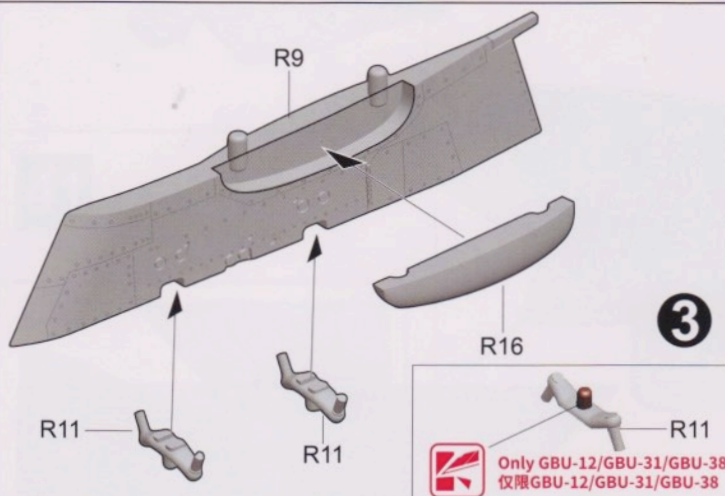

3

 Only GBU-12/GBU-31/GBU-38
仅限GBU-12/GBU-31/GBU-38

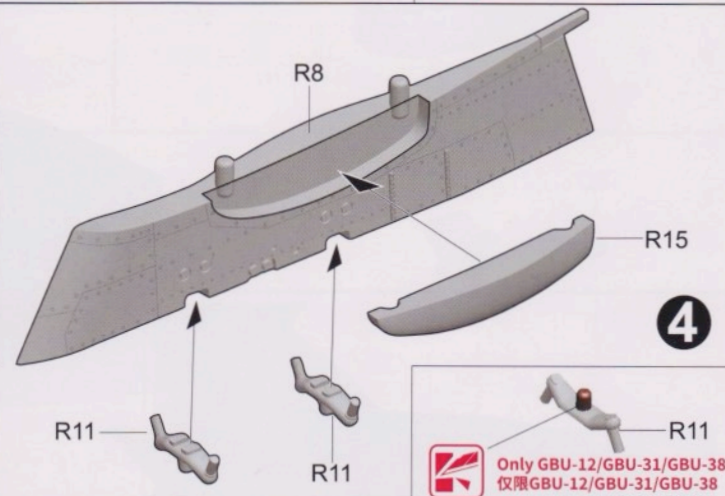

4

 Only GBU-12/GBU-31/GBU-38
仅限GBU-12/GBU-31/GBU-38

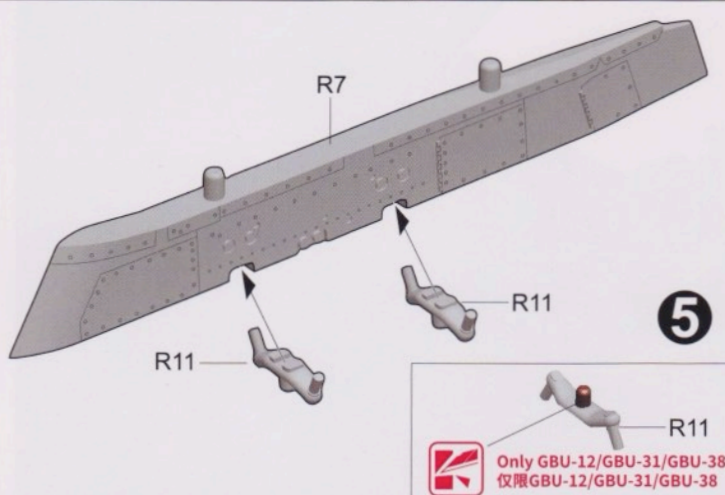

5

 Only GBU-12/GBU-31/GBU-38
仅限GBU-12/GBU-31/GBU-38

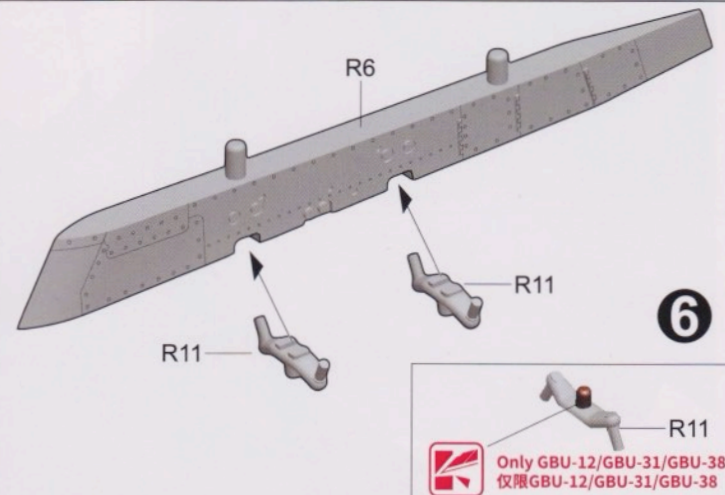

6

 Only GBU-12/GBU-31/GBU-38
仅限GBU-12/GBU-31/GBU-38

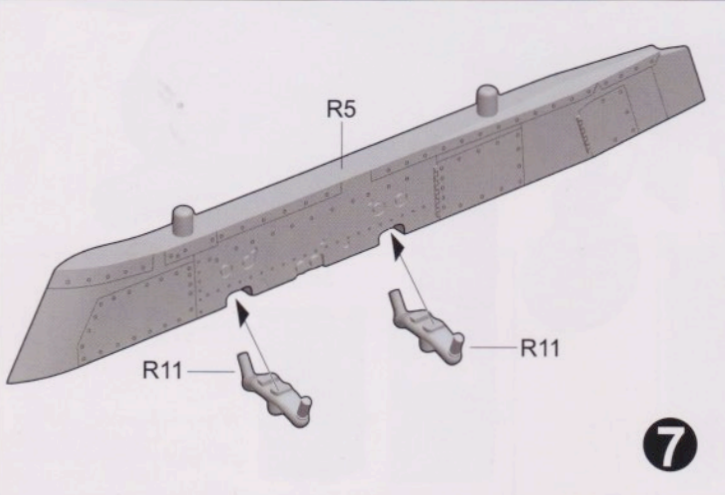

7

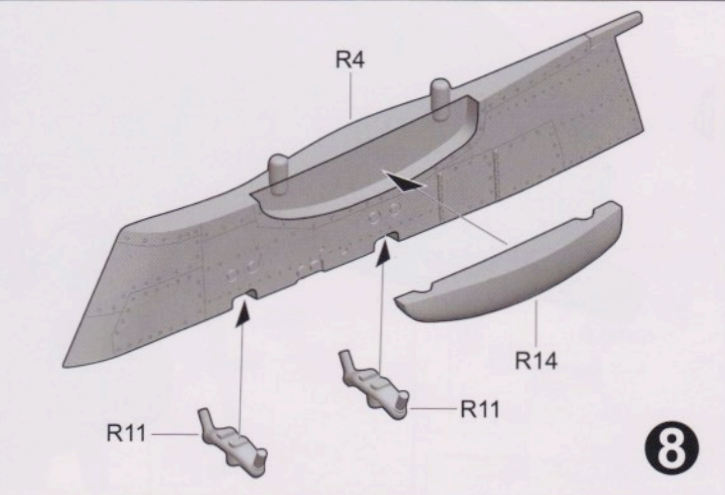

8

43

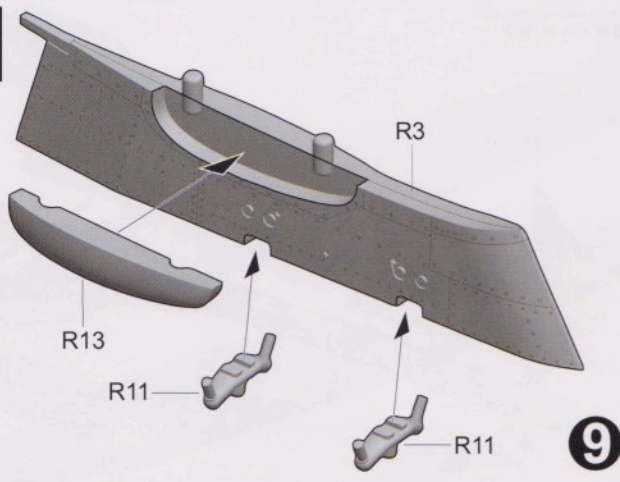

9

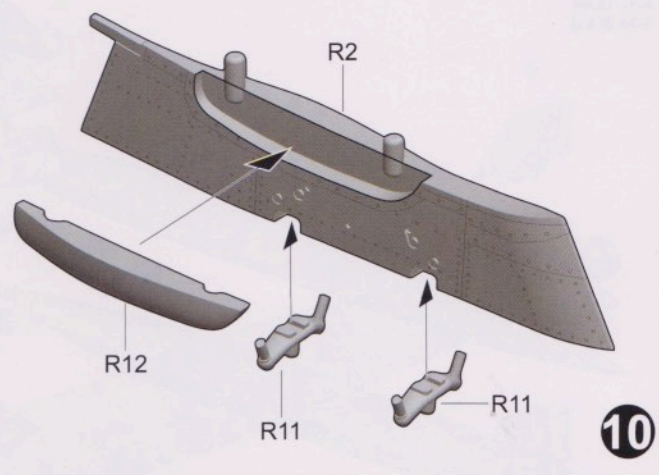

10

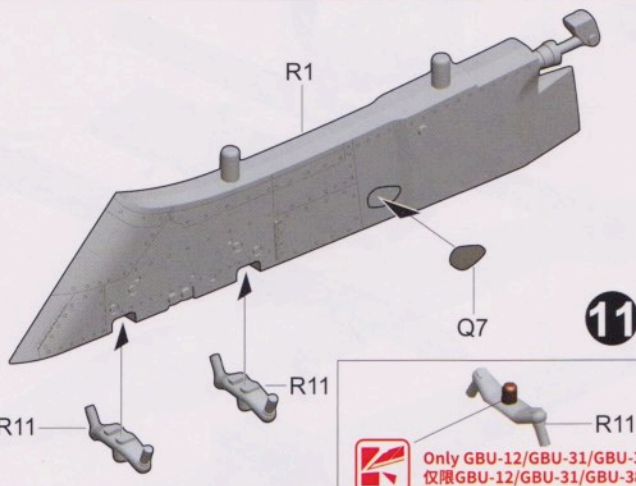

11

 Only GBU-12/GBU-31/GBU-38
仅限GBU-12/GBU-31/GBU-38

AGM-65 Maverick
小牛 空对地导弹

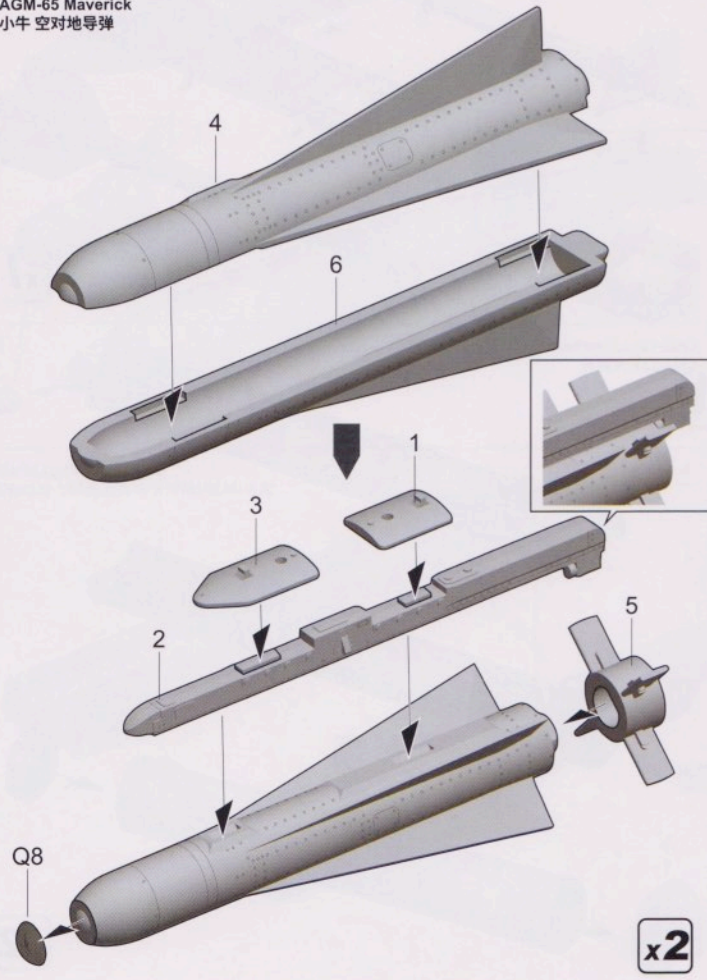

x2

AN/AAQ-33 POD
AN/AAQ-33 电子吊舱

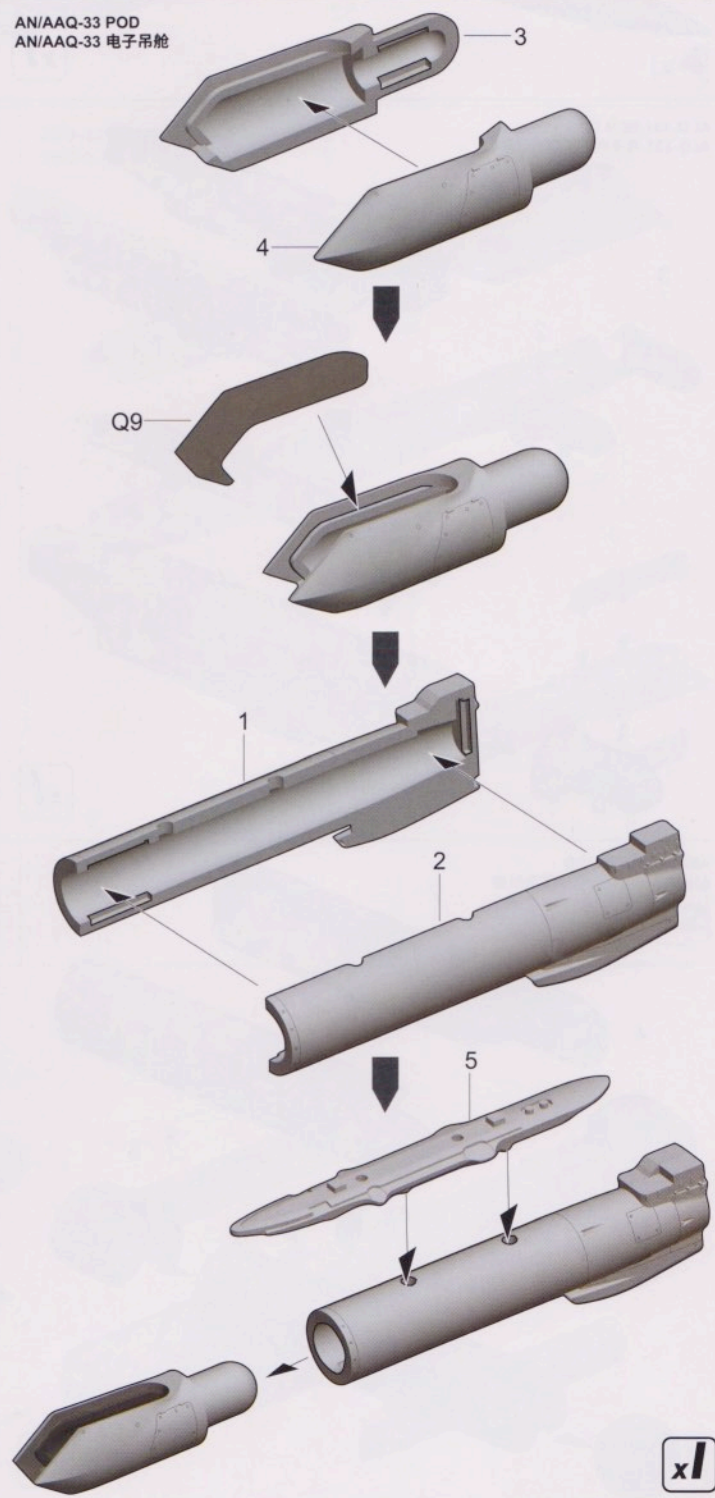

x1

A-10 TANK
A-10 副油箱

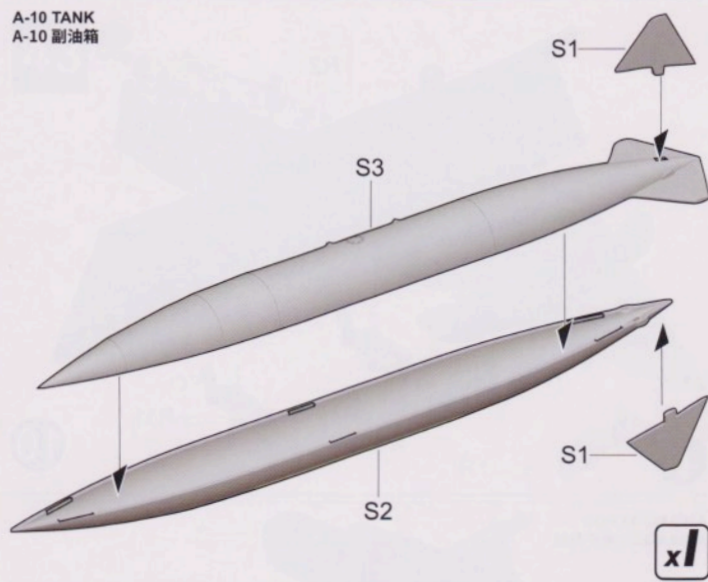

Twin AIM-9L missile
双联 AIM-9L 导弹

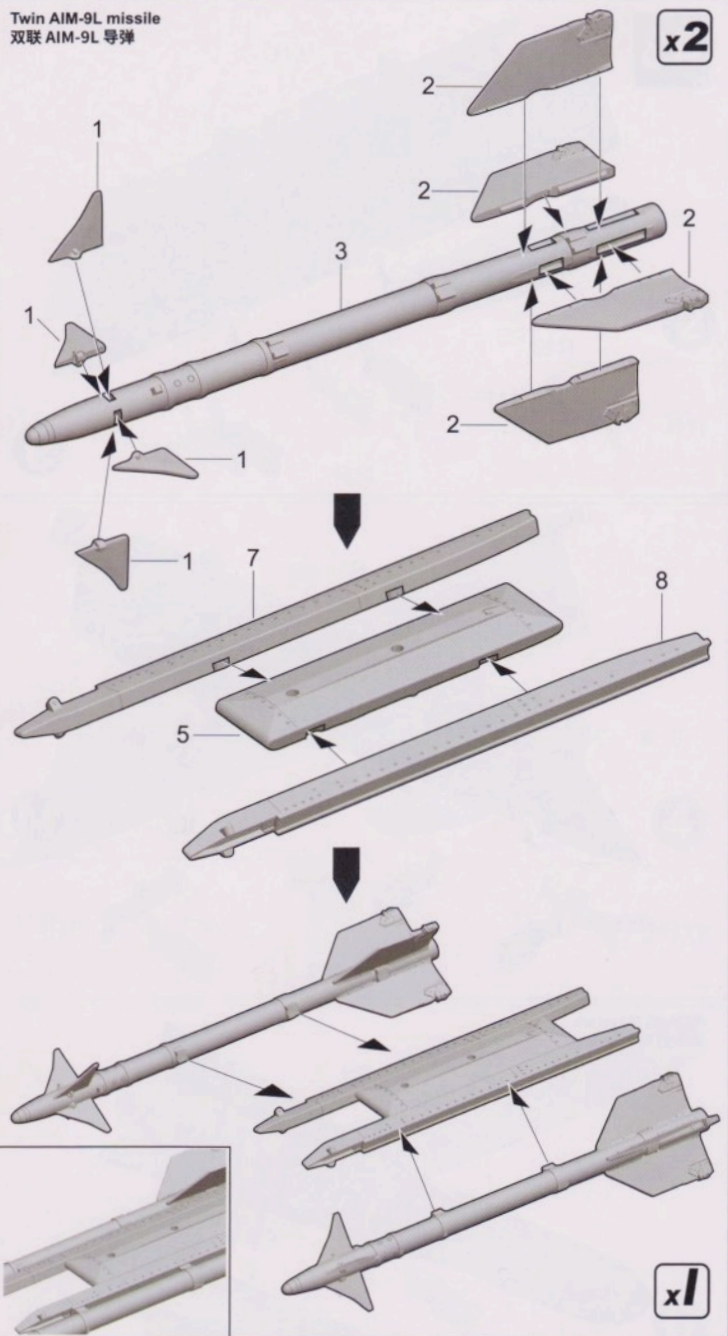

ALQ-131 ECM POD
ALQ-131 电子对抗(ECM)吊舱

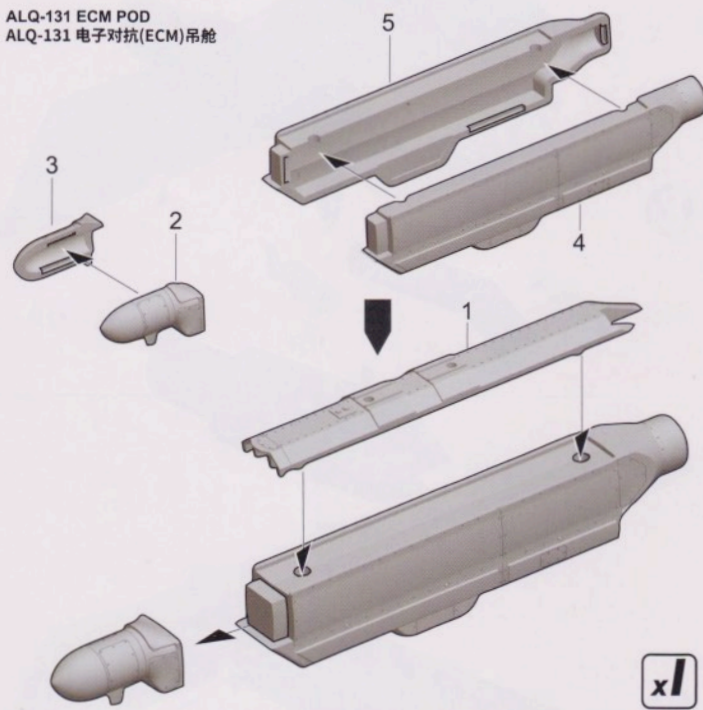

LAU-131 Launcher
LAU-131 火箭巢

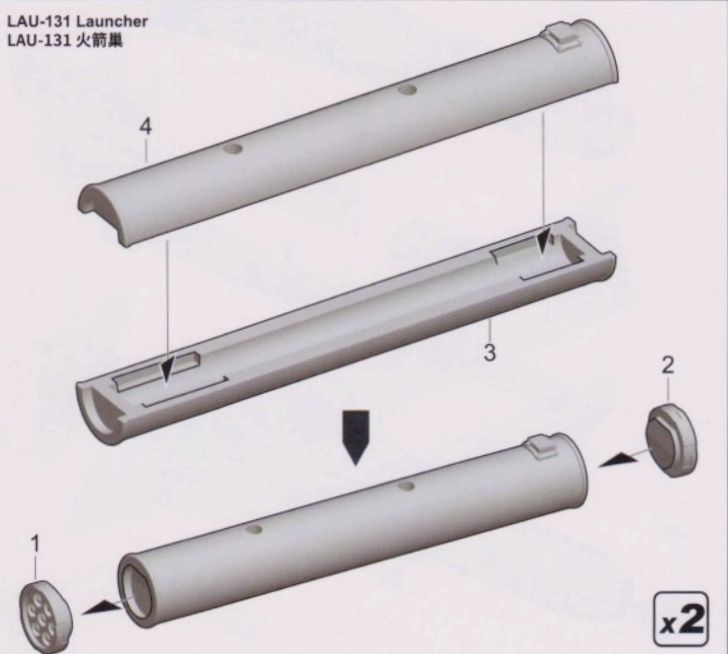

AN/AAQ-28(V) POD
AN/AAQ-28(V)闪电型瞄准吊舱

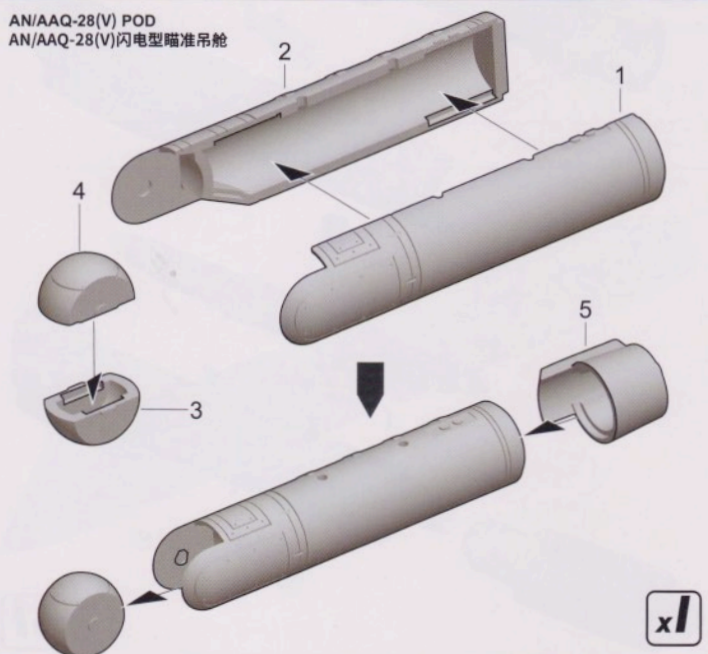

GBU-38 Bomb
GBU-38 炸弹

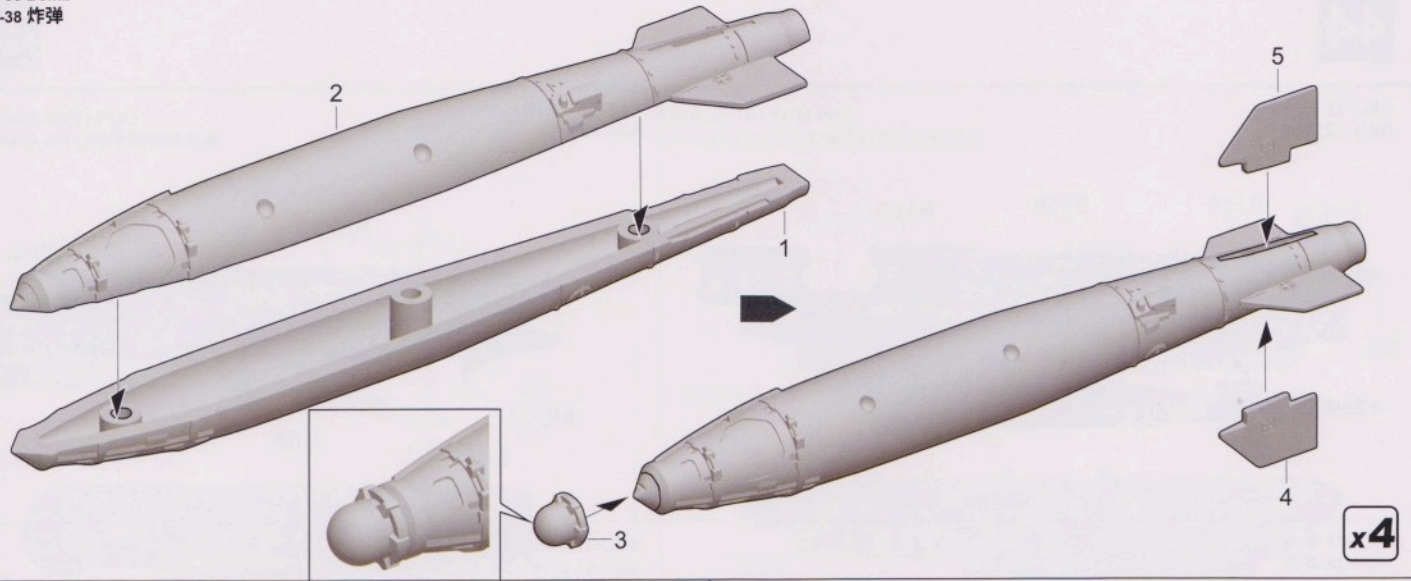

GBU-31 Bomb
GBU-31 炸弹

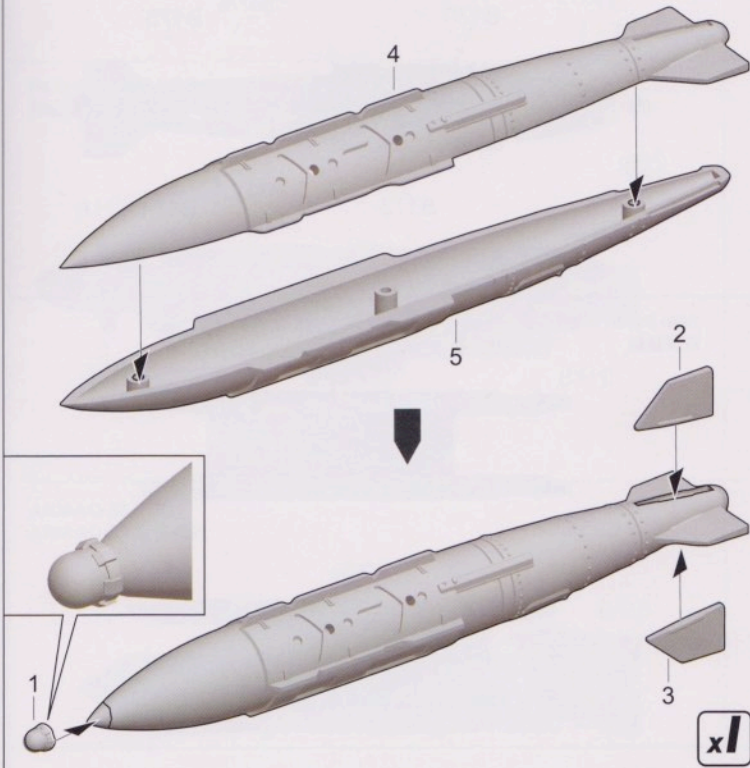

GBU-12 Bomb
GBU-12 炸弹

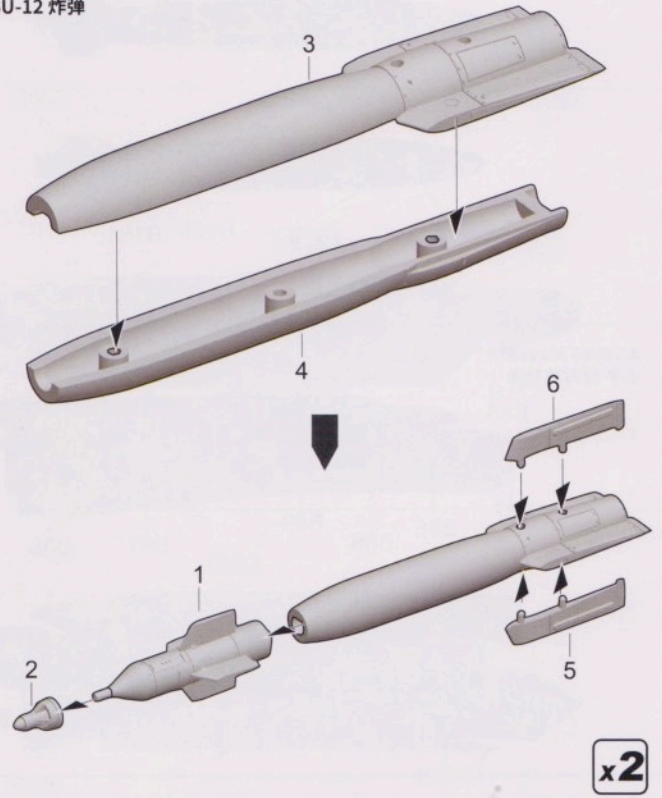

AN/ALQ-184 ECM POD
AN/ALQ-184自卫式电子对抗(ECM)吊舱

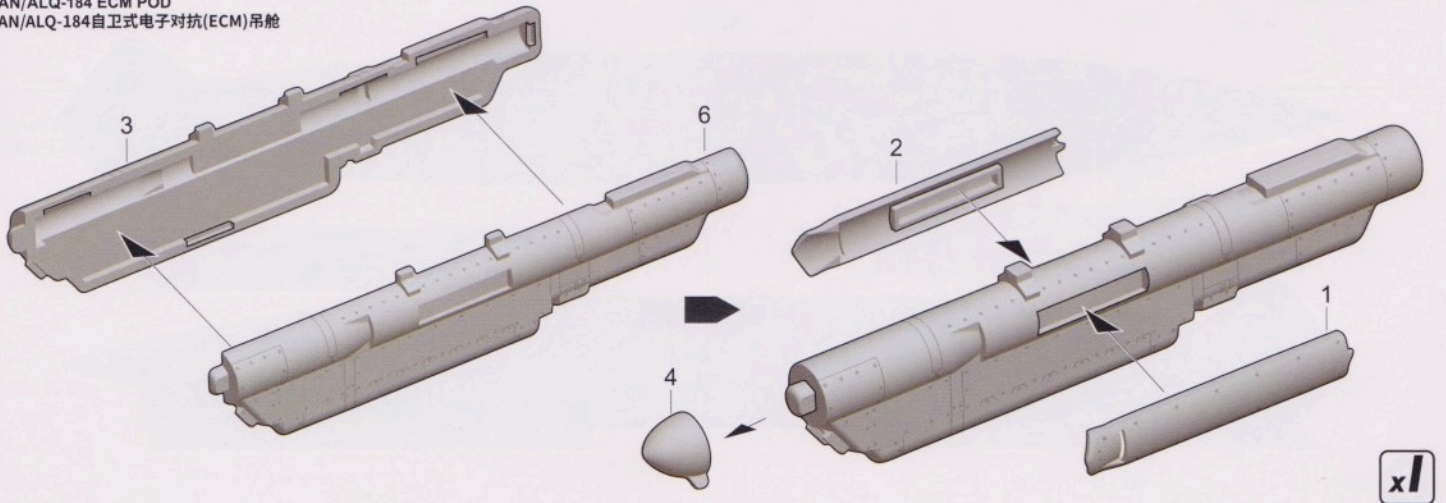

GBU-12 Bomb
GBU-12 炸弹

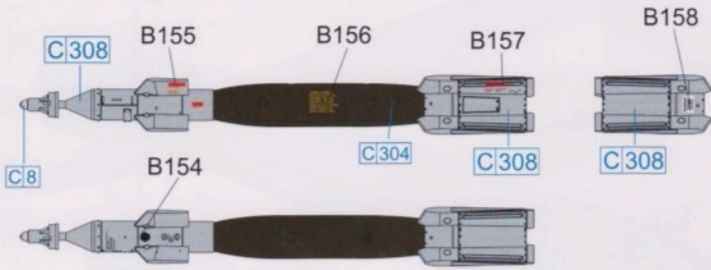

AIM-9L Missile
AIM-9L 导弹

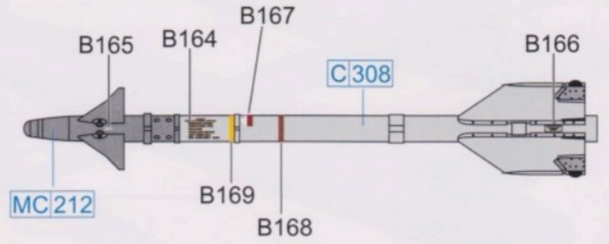

GBU-38 Bomb
GBU-38 炸弹



GBU-31 Bomb
GBU-31 炸弹

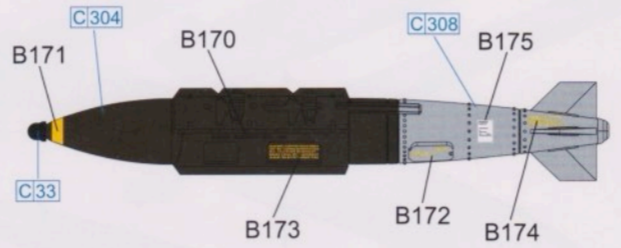

AGM-65 Maverick
小牛 空对地导弹

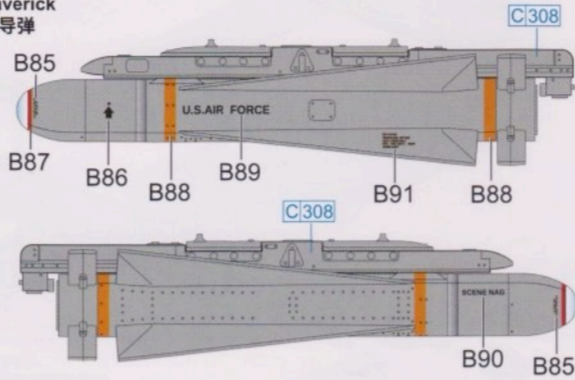

Twin Pylon
双联挂架

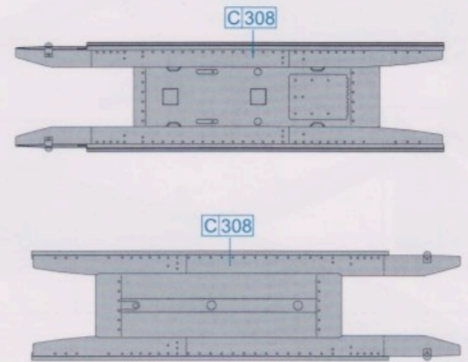

A-10 TANK
A-10 TANK 副油箱

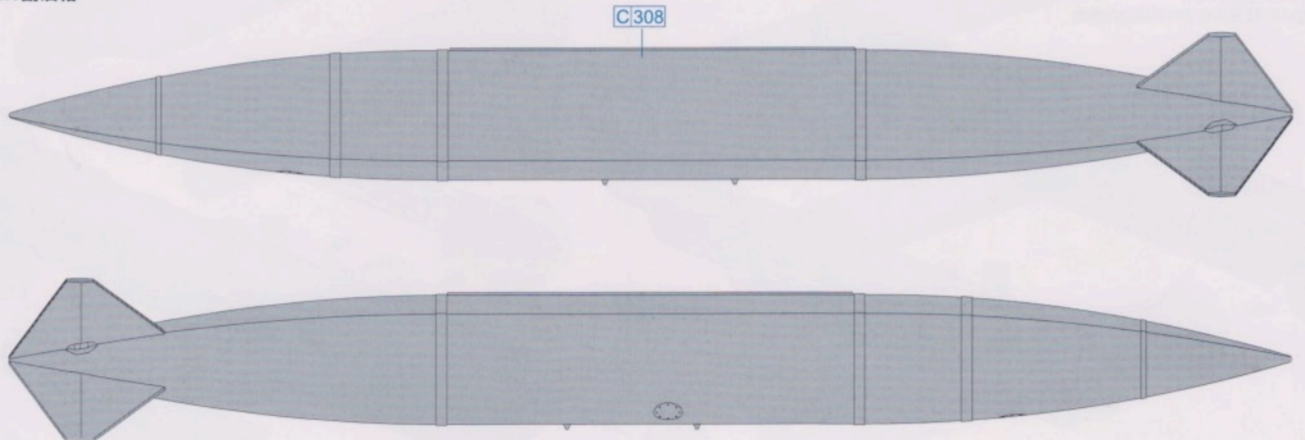

AN/AAQ-28(V) POD
AN/AAQ-28(V)闪电型瞄准吊舱

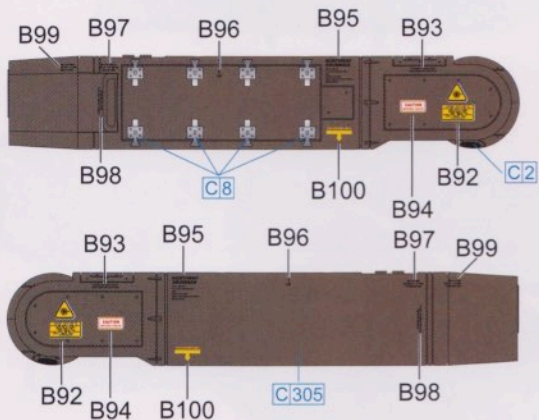

AN/ALQ-184 ECM POD
AN/ALQ-184自卫式电子对抗(ECM)吊舱

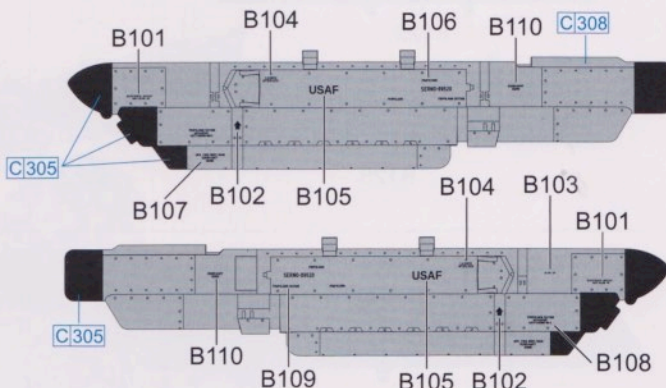

ALQ-131 ECM POD
ALQ-131 电子对抗(ECM)吊舱

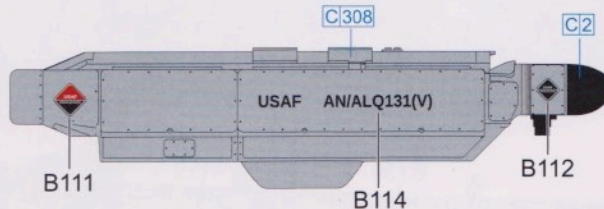
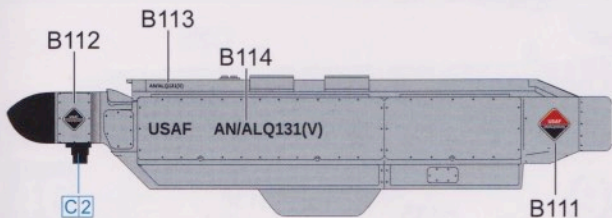

AN/AAQ-33 POD
AN/AAQ-33 电子吊舱

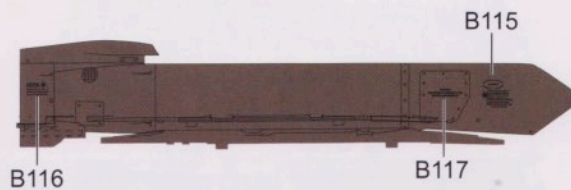
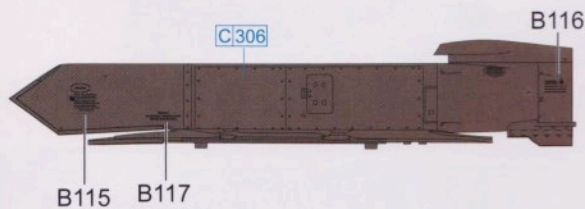

LAU-131 Launcher
LAU-131 火箭巢

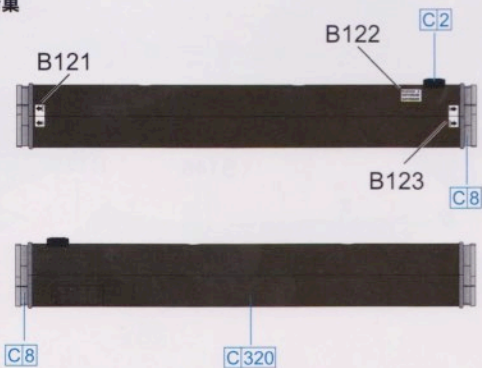

Pylon
挂架

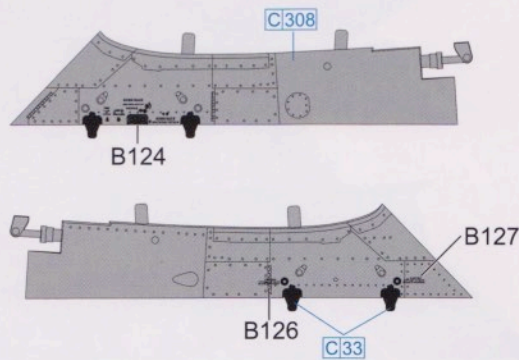

Pylon 挂架

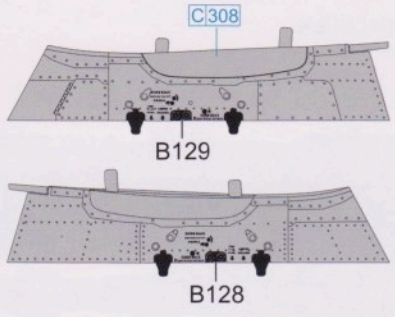

2

Pylon 挂架

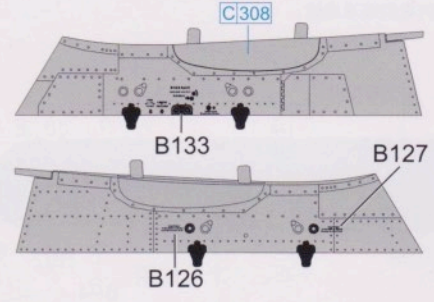

3

Pylon 挂架

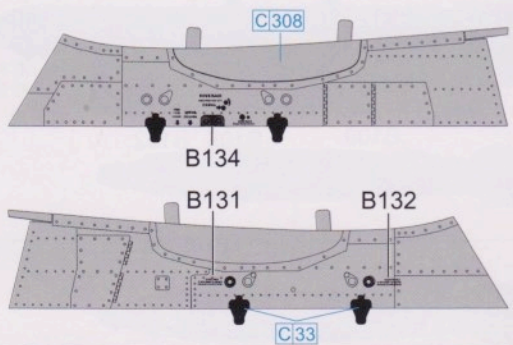

4

Pylon 挂架

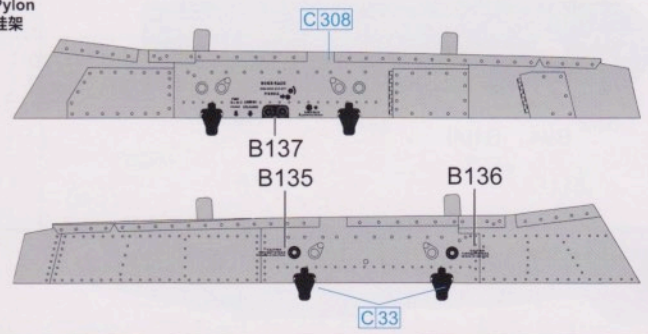

5

Pylon 挂架

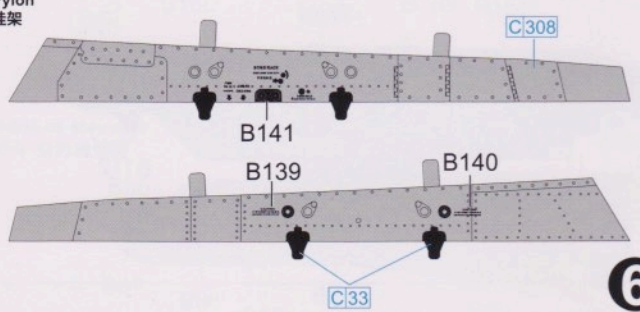

6

Pylon 挂架

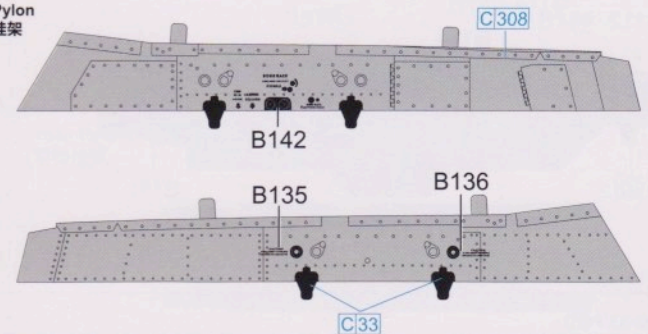

7

Pylon 挂架

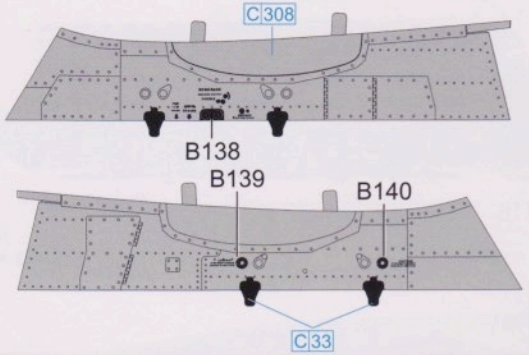

8

Pylon 挂架

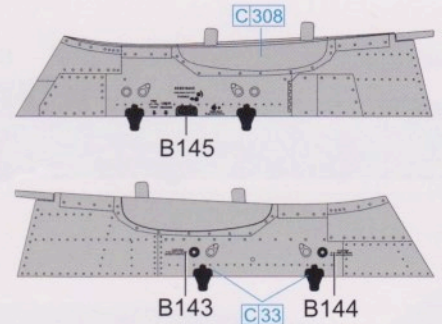

9

Pylon 挂架

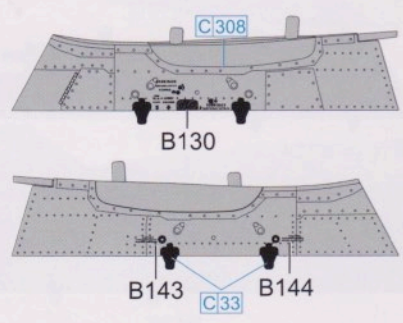

10

Pylon 挂架

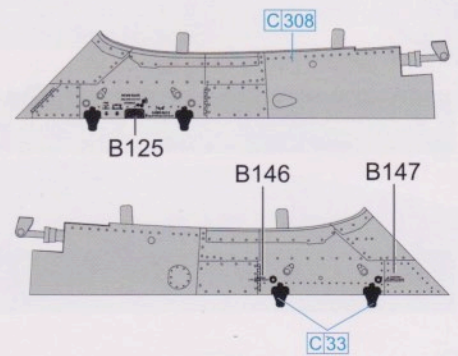

11

46

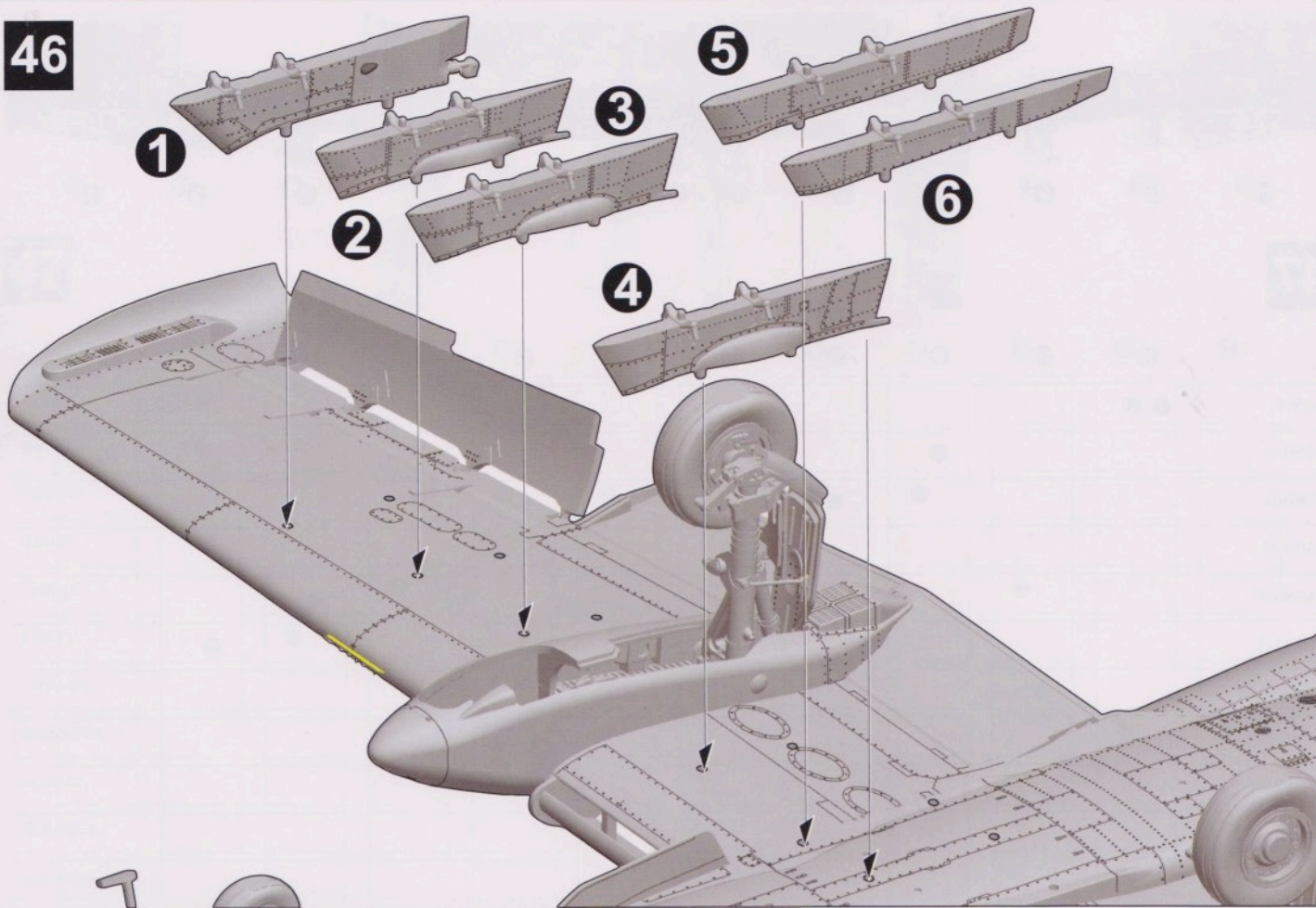

46

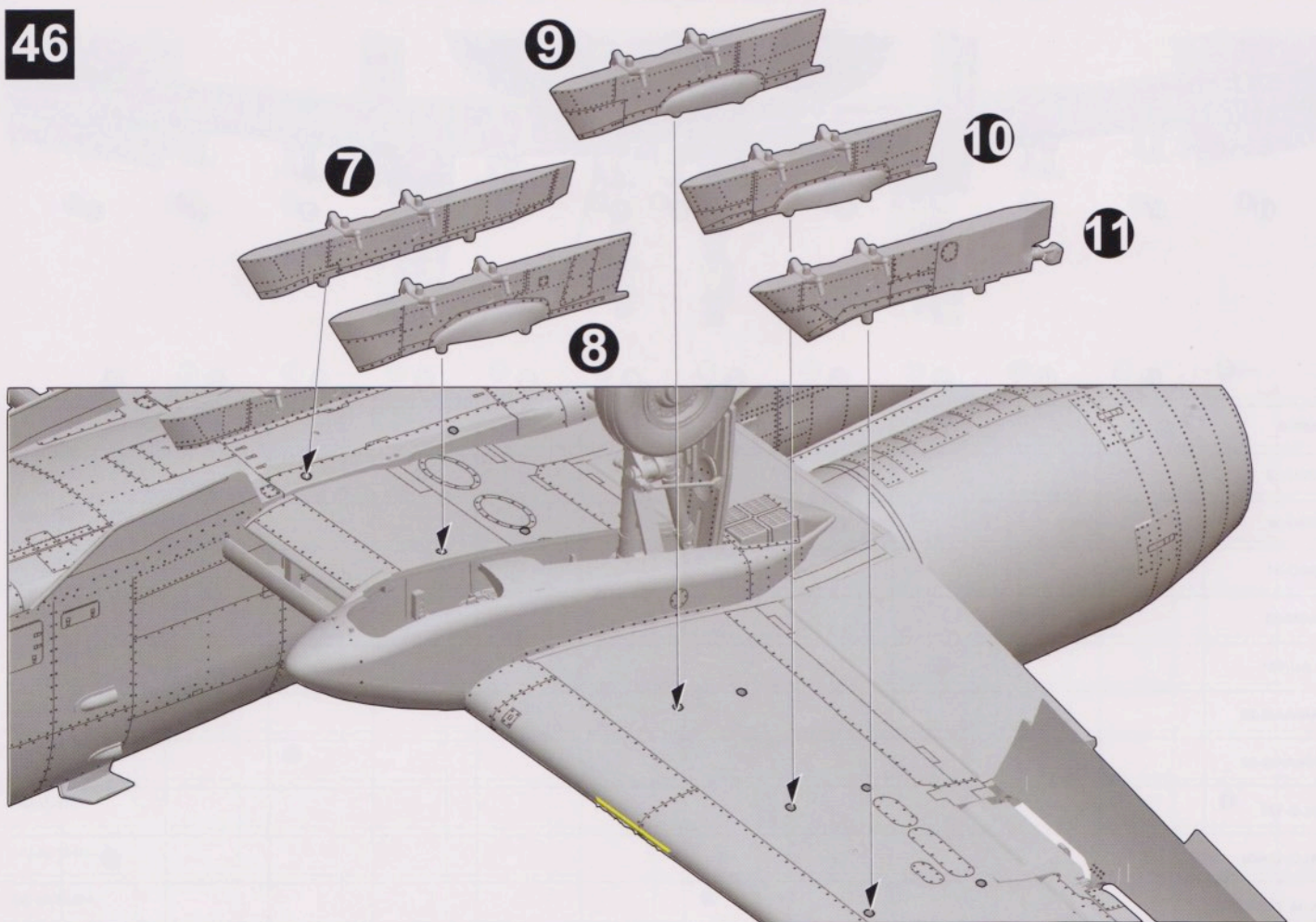

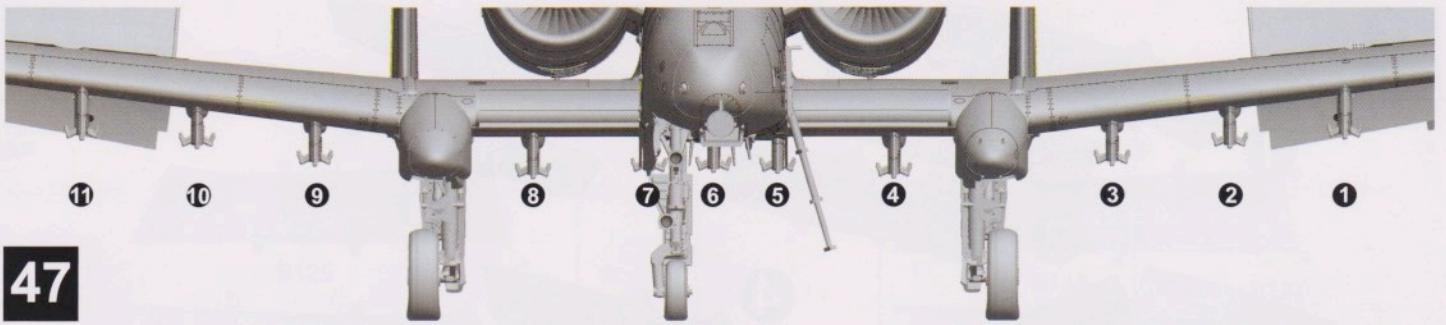

47

Weapon Ordinance 1
挂载方案 1

| | 11 | 10 | 9 | 8 | 7 | 6 | 5 | 4 | 3 | 2 | 1 |
|------------|-----|----|---|---|---|---|---|---|---|---|---|
| AIM-9 | ● ● | | | | | | | | | | |
| GBU-12 | | | ● | | | | | | | | ● |
| GBU-38 | | | | ● | | | ● | ● | | | |
| GBU-31 | | | | | ● | | | | | | |
| AGM-65 | | | | | | | | | ● | | |
| LAU-131 | | | | | | | | | | ● | |
| AN/AAQ-28 | | ● | | | | | | | | | |
| AN/AAQ-33 | | | | | | | | | | | |
| ALQ-131 | | | | | | | | | | | |
| ALQ-184(3) | | | | | | | | | | | |
| A-10 TANK | | | | | | | | | | | |

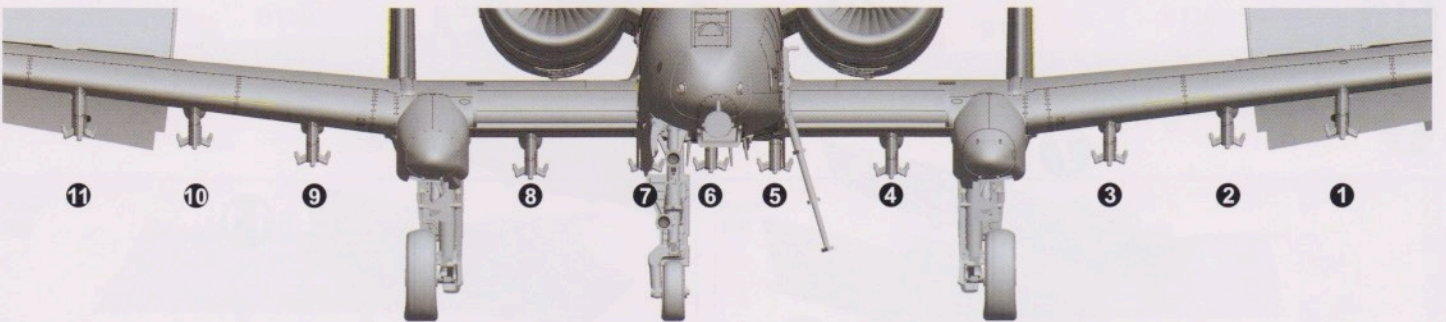

Weapon Ordinance 2
挂载方案 2

| | 11 | 10 | 9 | 8 | 7 | 6 | 5 | 4 | 3 | 2 | 1 |
|------------|-----|----|---|---|---|---|---|---|---|---|---|
| AIM-9 | ● ● | | | | | | | | | | |
| GBU-12 | | | | | | | | ● | | | |
| GBU-38 | | | | ● | ● | | ● | | | | |
| GBU-31 | | | | | | | | | | | |
| AGM-65 | | | | | | | | | ● | | |
| LAU-131 | | | ● | | | | | | | ● | |
| AN/AAQ-28 | | ● | | | | | | | | | |
| AN/AAQ-33 | | | | | | | | | | | |
| ALQ-131 | | | | | | | | | | | |
| ALQ-184(3) | | | | | | | | | | | ● |
| A-10 TANK | | | | | | | | | | | |

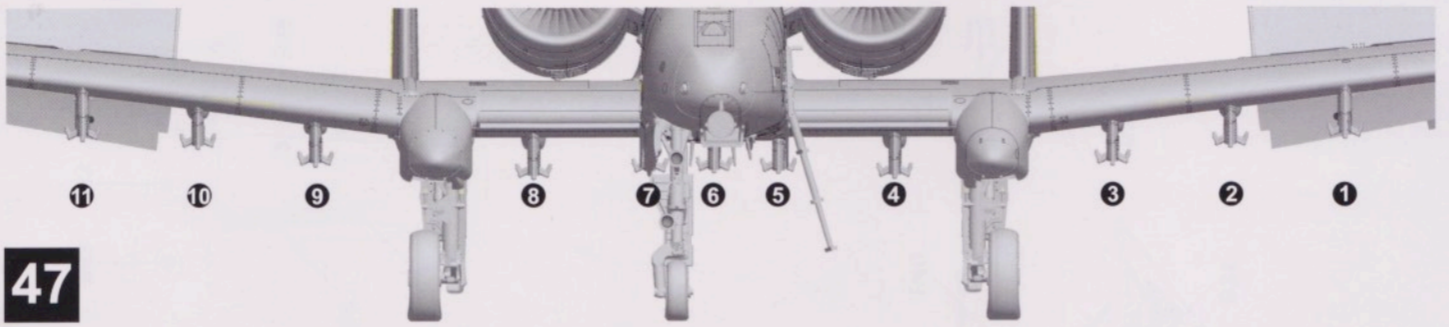

47

Weapon Ordance 3
挂载方案 3

| | 11 | 10 | 9 | 8 | 7 | 6 | 5 | 4 | 3 | 2 | 1 |
|------------|-----|----|---|---|---|---|---|---|---|---|---|
| AIM-9 | ● ● | | | | | | | | | | |
| GBU-12 | | | | | | | | | | | |
| GBU-38 | | | | ● | ● | | ● | ● | | | |
| GBU-31 | | | | | | | | | | | |
| AGM-65 | | | ● | | | | | | ● | | |
| LAU-131 | | ● | | | | | | | | | |
| AN/AAQ-28 | | | | | | | | | | | |
| AN/AAQ-33 | | | | | | | | | | ● | |
| ALQ-131 | | | | | | | | | | | |
| ALQ-184(2) | | | | | | | | | | | ● |
| A-10 TANK | | | | | | | | | | | |

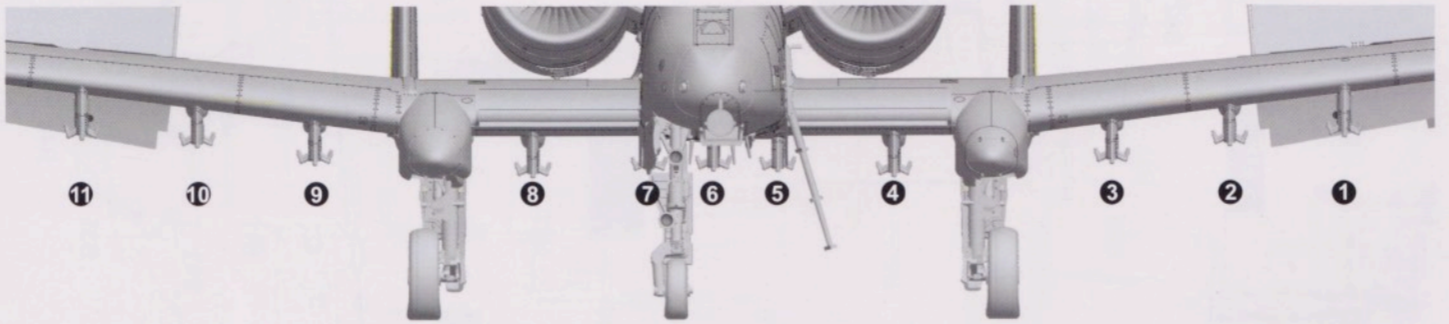

Weapon Ordance 4
挂载方案 4

| | 11 | 10 | 9 | 8 | 7 | 6 | 5 | 4 | 3 | 2 | 1 |
|------------|-----|----|---|---|---|---|---|---|---|---|---|
| AIM-9 | ● ● | | | | | | | | | | |
| GBU-12 | | | | | | | | | | | |
| GBU-38 | | | | ● | | | | ● | | | |
| GBU-31 | | | | | | | | | | | |
| AGM-65 | | | ● | | | | | | ● | | |
| LAU-131 | | | | | | | | | | | |
| AN/AAQ-28 | | | | | | | | | | | |
| AN/AAQ-33 | | ● | | | | | | | | | |
| ALQ-131 | | | | | | | | | | | ● |
| ALQ-184(2) | | | | | | | | | | | |
| A-10 TANK | | | | | | ● | | | | | |

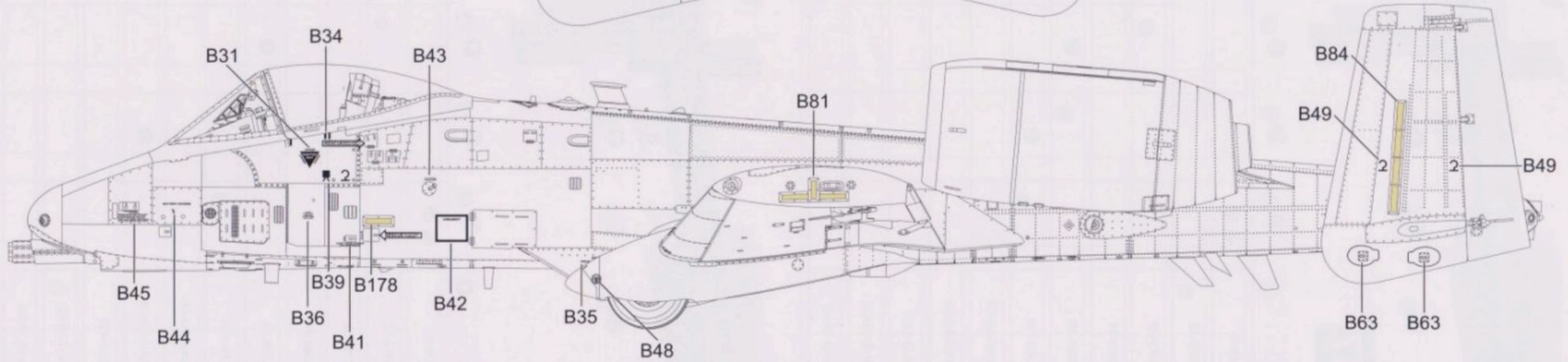
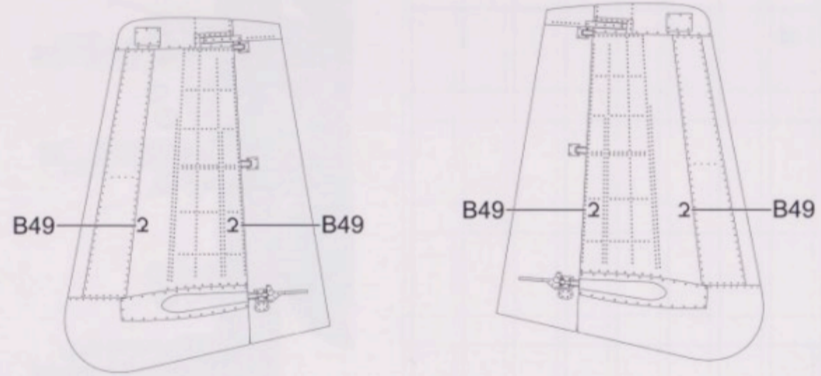
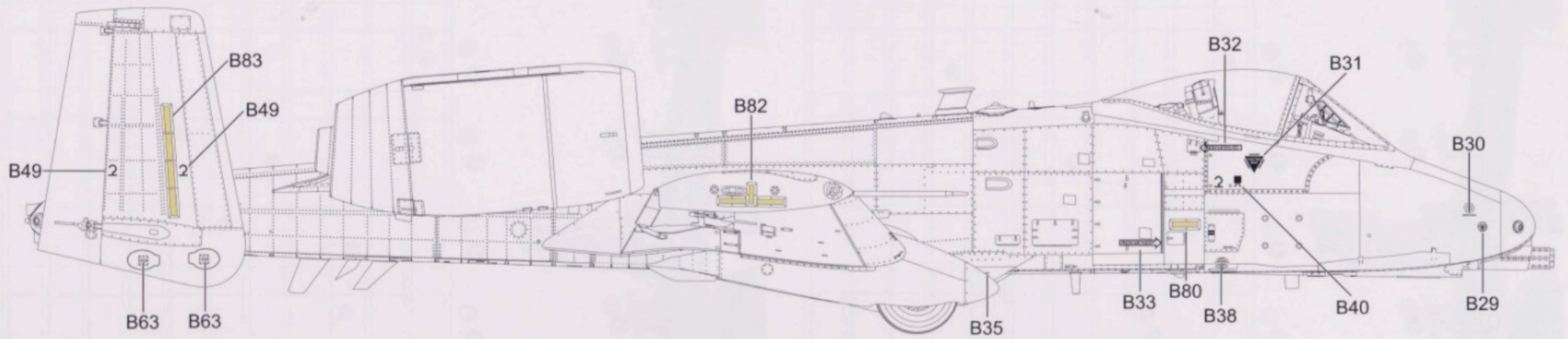

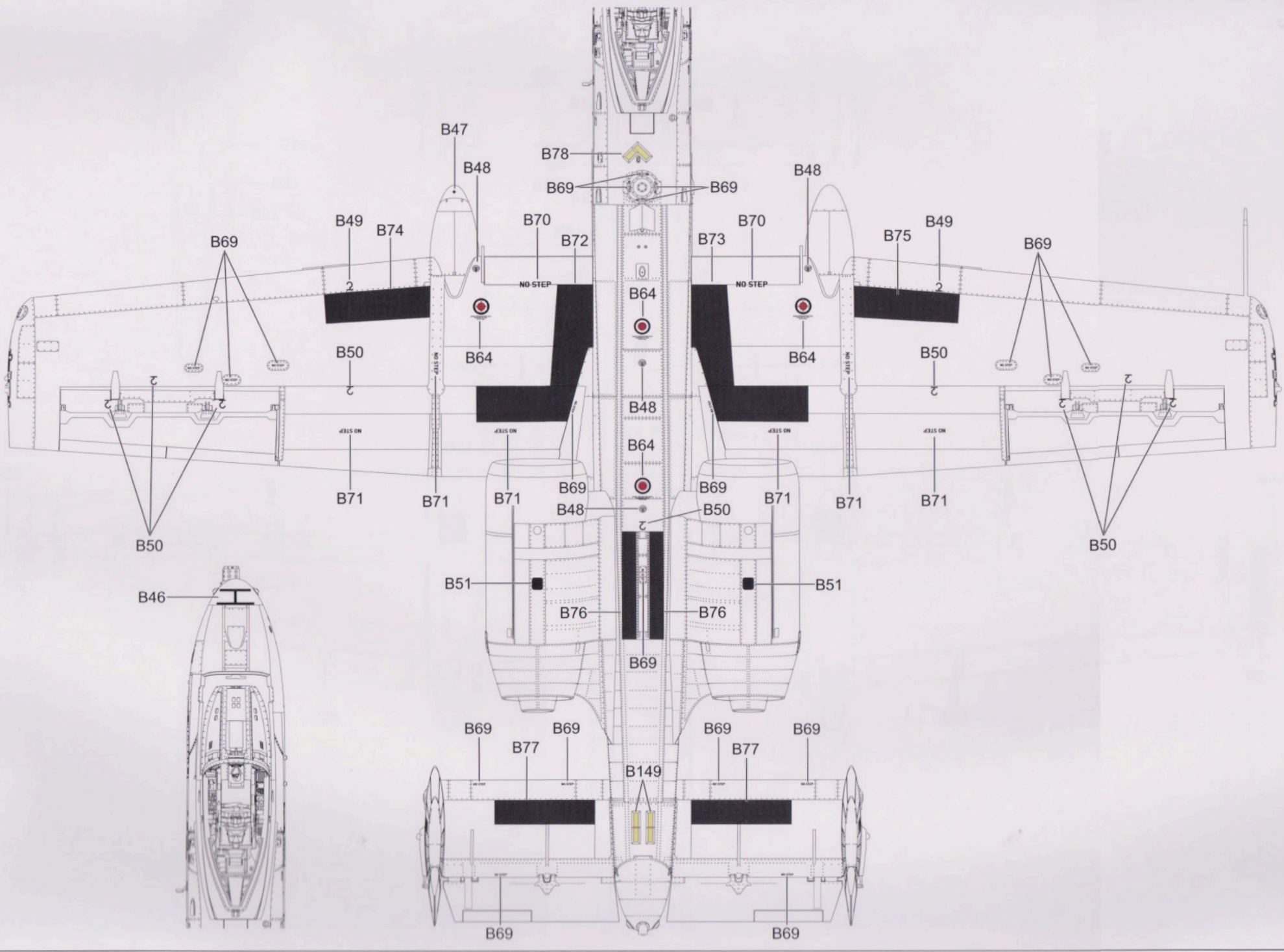

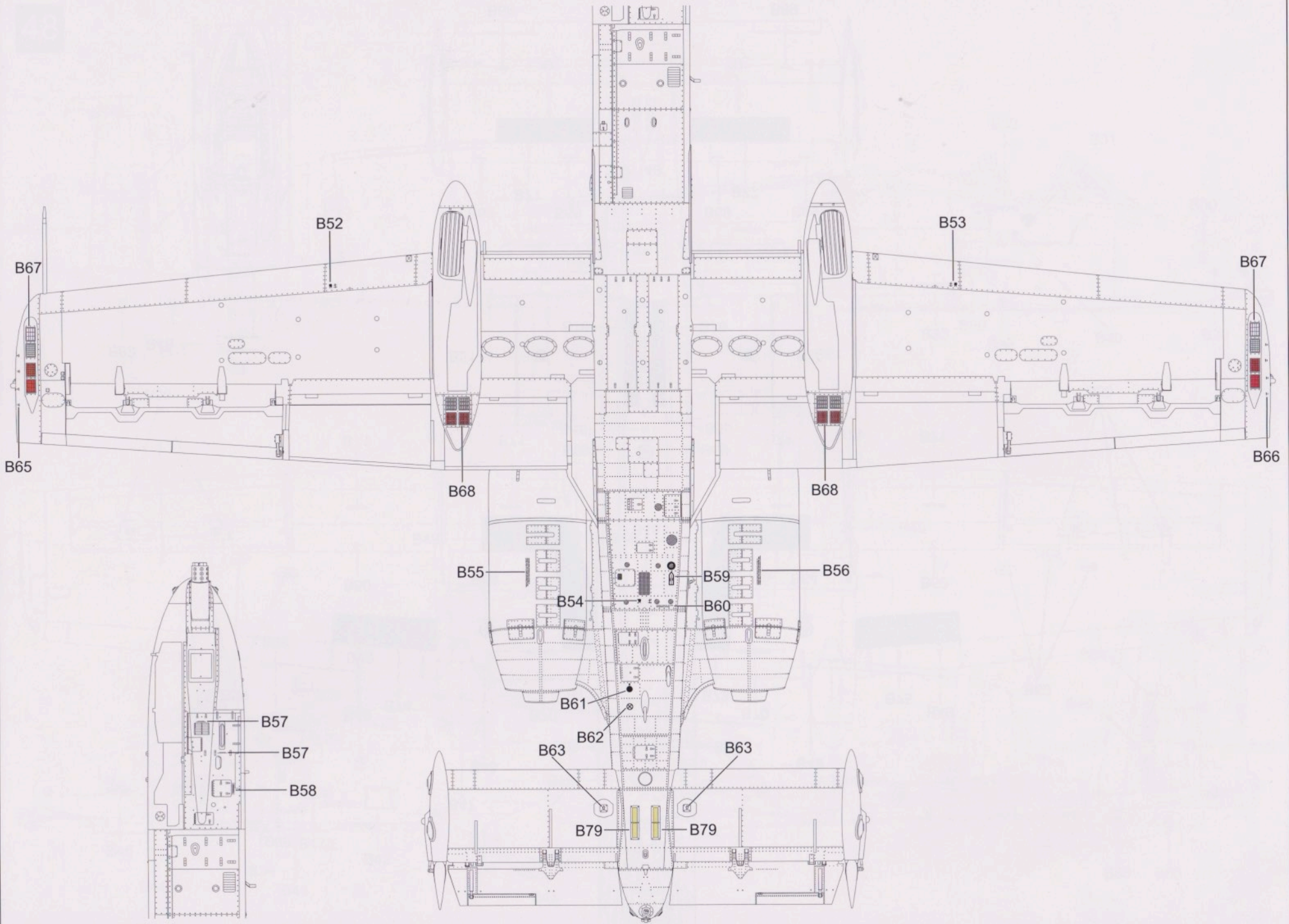



A-10C THUNDERBOLT II

雷電二式 近距离支援攻击机
CLOSE AIR SUPPORT ATTACK AIRCRAFT

1/48 SCALE AIR CRAFT L4829

涂装指示 PAINTING マーキングと塗装図



A 82-0661 163rd Fighter Squadron, 122nd Fighter Wing, Afghanistan, USANG, 2018
82-0661 美国空中国民警卫队 第122战斗机联队 163战斗机中队 阿富汗 2018

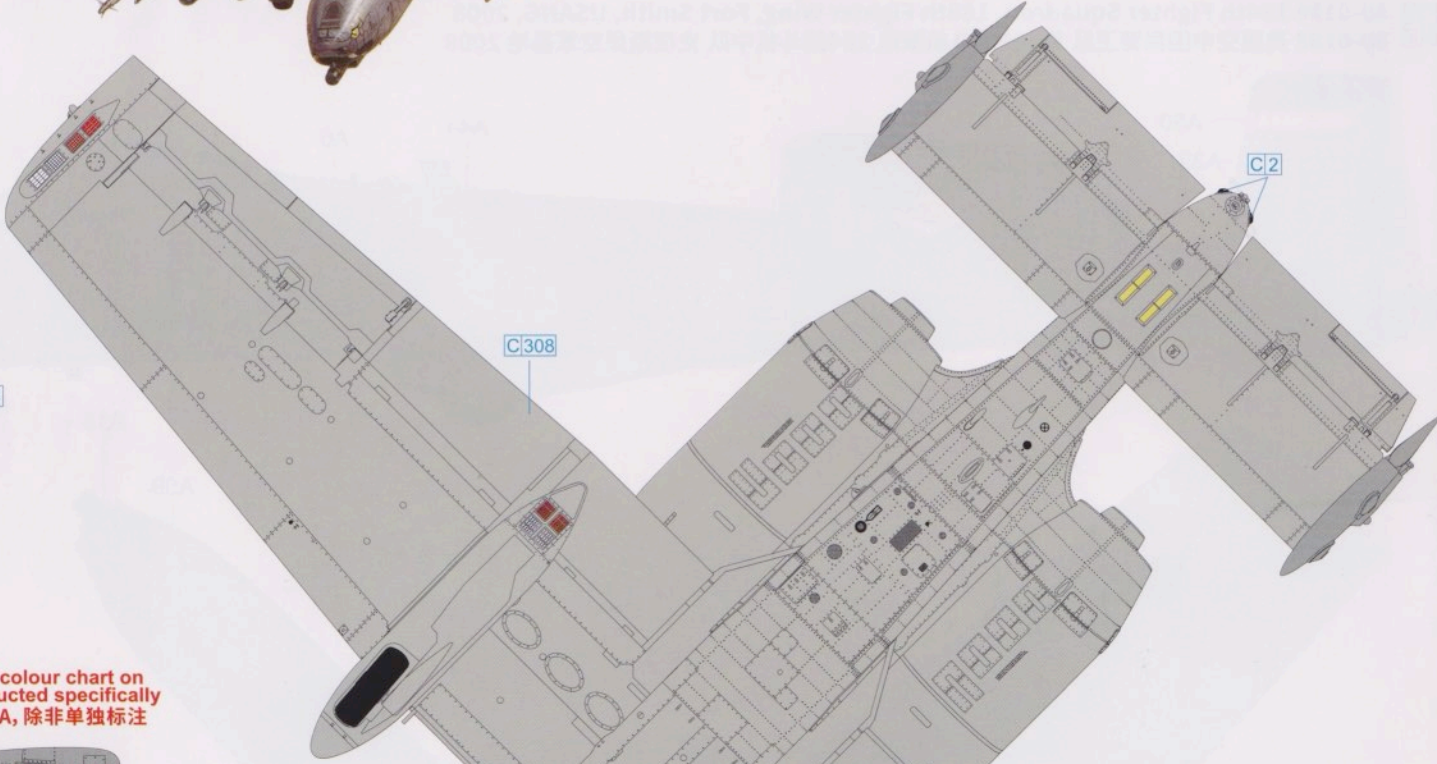
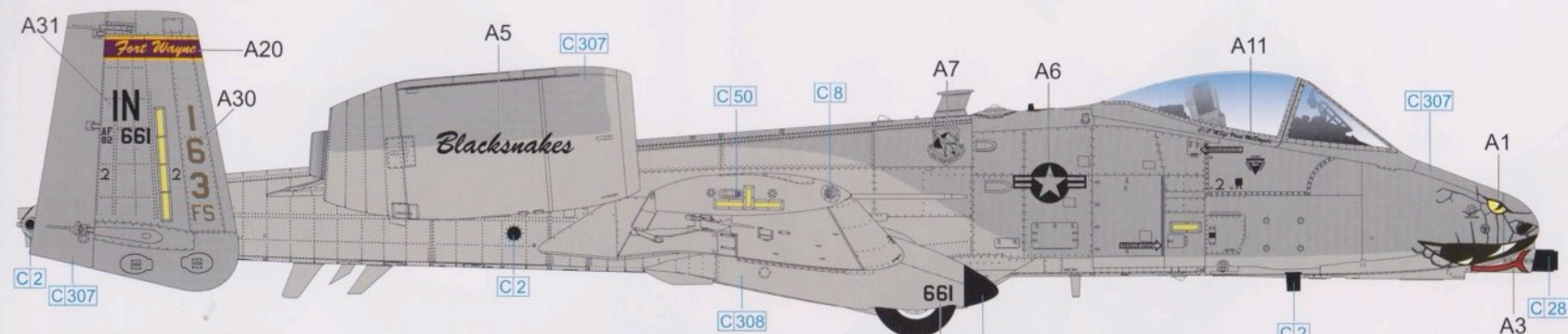

! Please refer to scheme A for colour chart on common details, unless instructed specifically
通用细节颜色漆号请参考涂装A, 除非单独标注

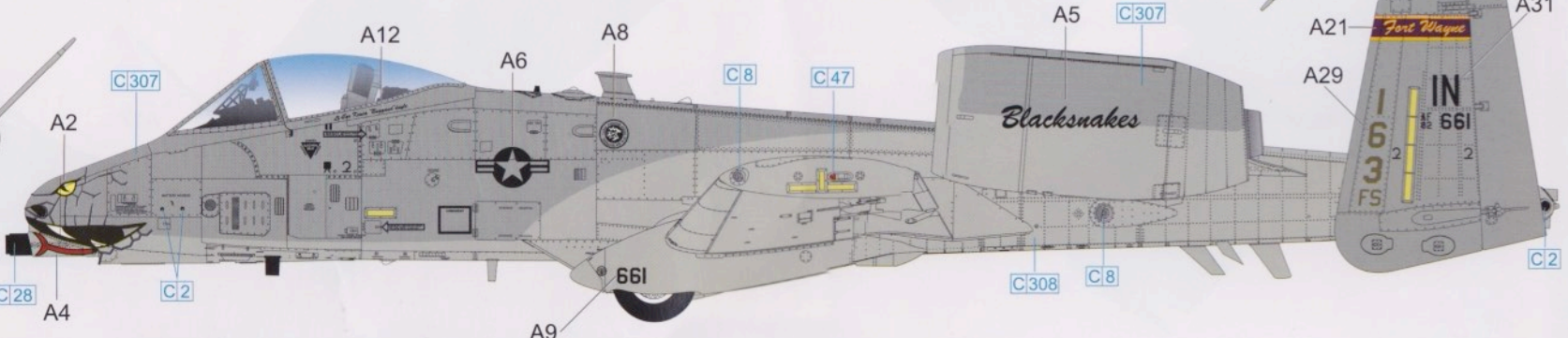
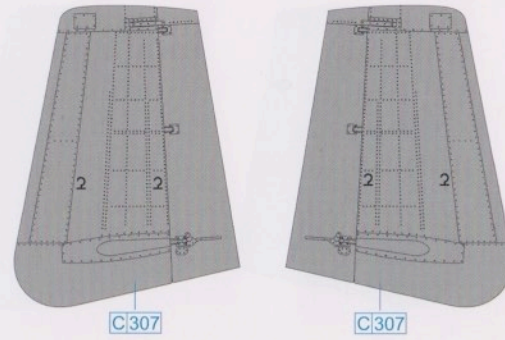



A-10C THUNDERBOLT II

雷电二式 近距离支援攻击机
CLOSE AIR SUPPORT ATTACK AIRCRAFT

1/48 SCALE AIR CRAFT L4829
涂装指示 PAINTING マーキングと塗装図



B 80-0188 184th Fighter Squadron, 188th Fighter Wing, Fort Smith, USANG, 2008
80-0188 美国空中国民警卫队 第188战斗机联队 184战斗机中队 史密斯堡空军基地 2008

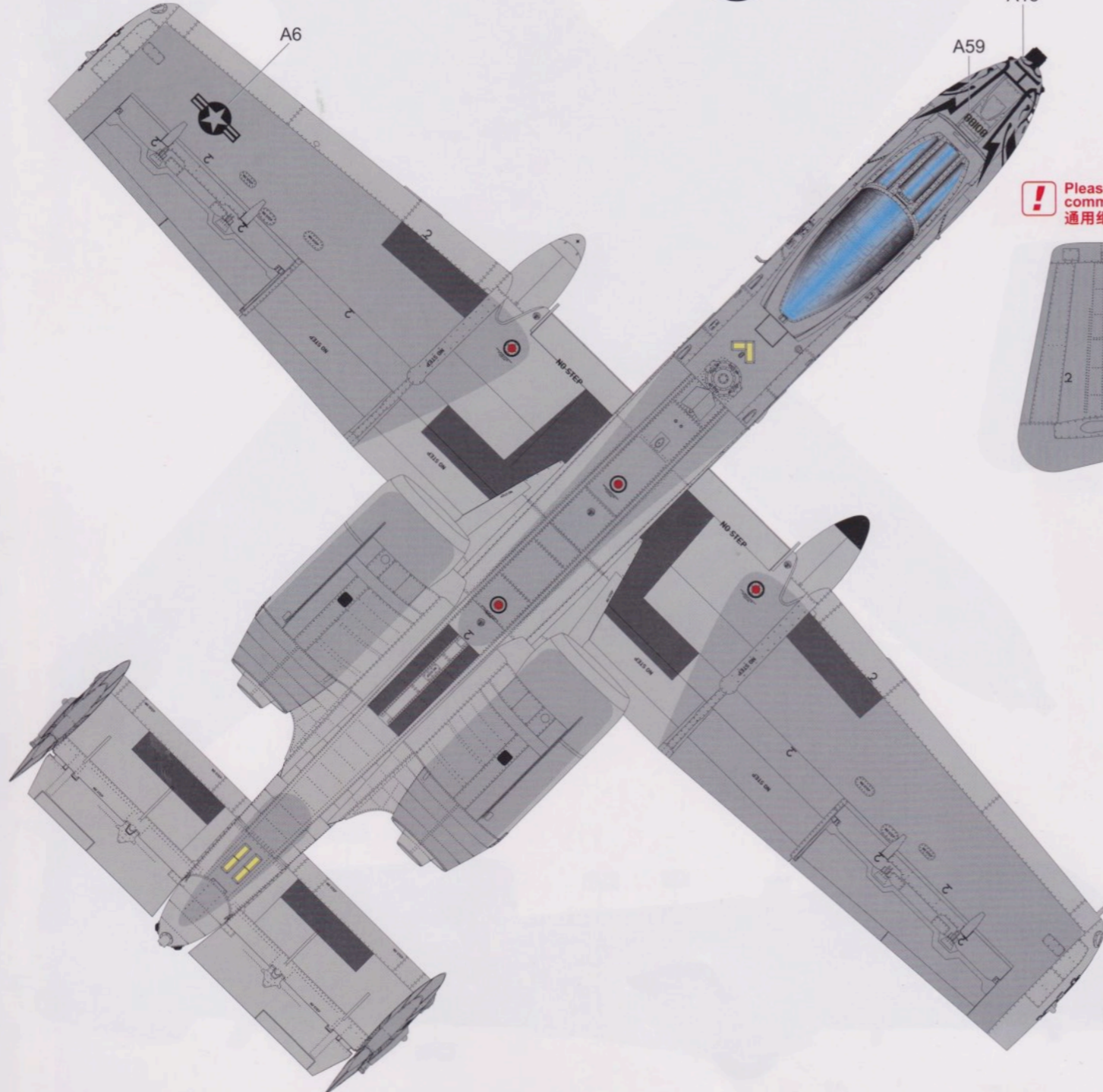
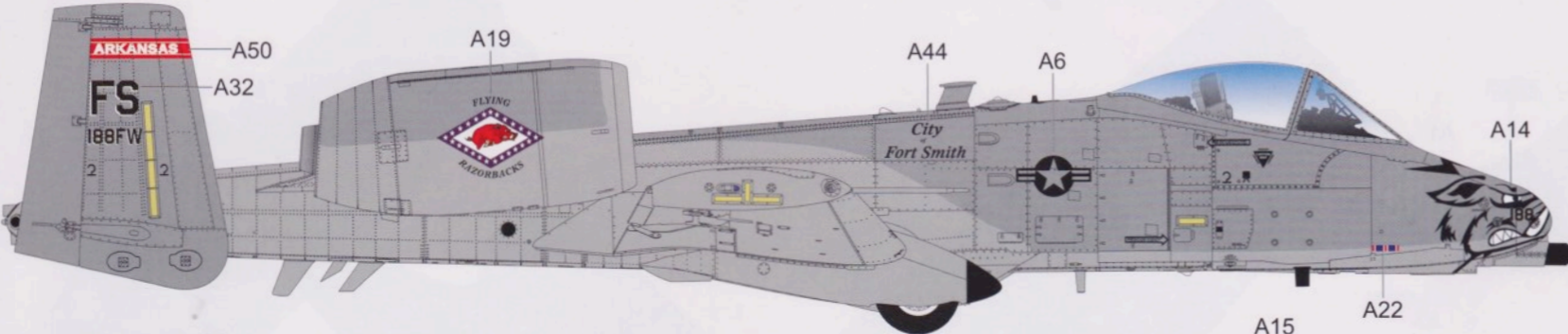

! Please refer to scheme A for colour chart on common details, unless instructed specifically
通用细节颜色漆号请参考涂装A, 除非单独标注

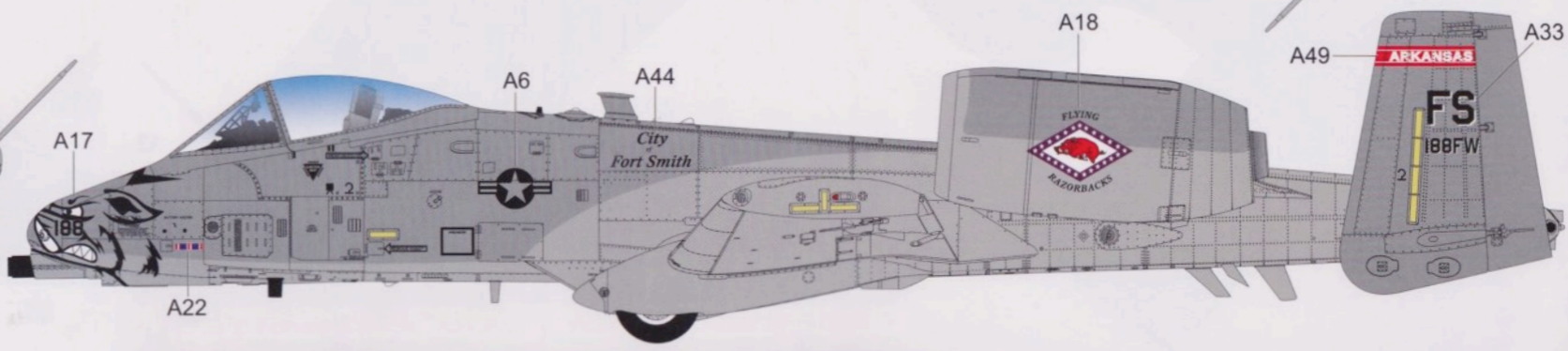
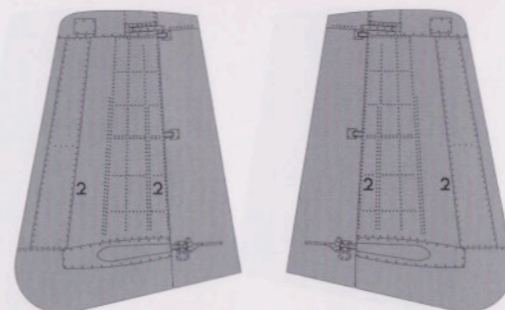



A-10C THUNDERBOLT II

雷電二式 近距离支援攻击机
CLOSE AIR SUPPORT ATTACK AIRCRAFT

1/48 SCALE AIR CRAFT L4829

涂装指示 PAINTING マーキングと塗装図



C 78-0684 354th Fighter Squadron, 355th Fighter Wing, Davis-Monthan AFB, USAF, 2020
78-0684 美国空军 第355战斗机联队 354战斗机中队 戴维斯-蒙森空军基地 2020

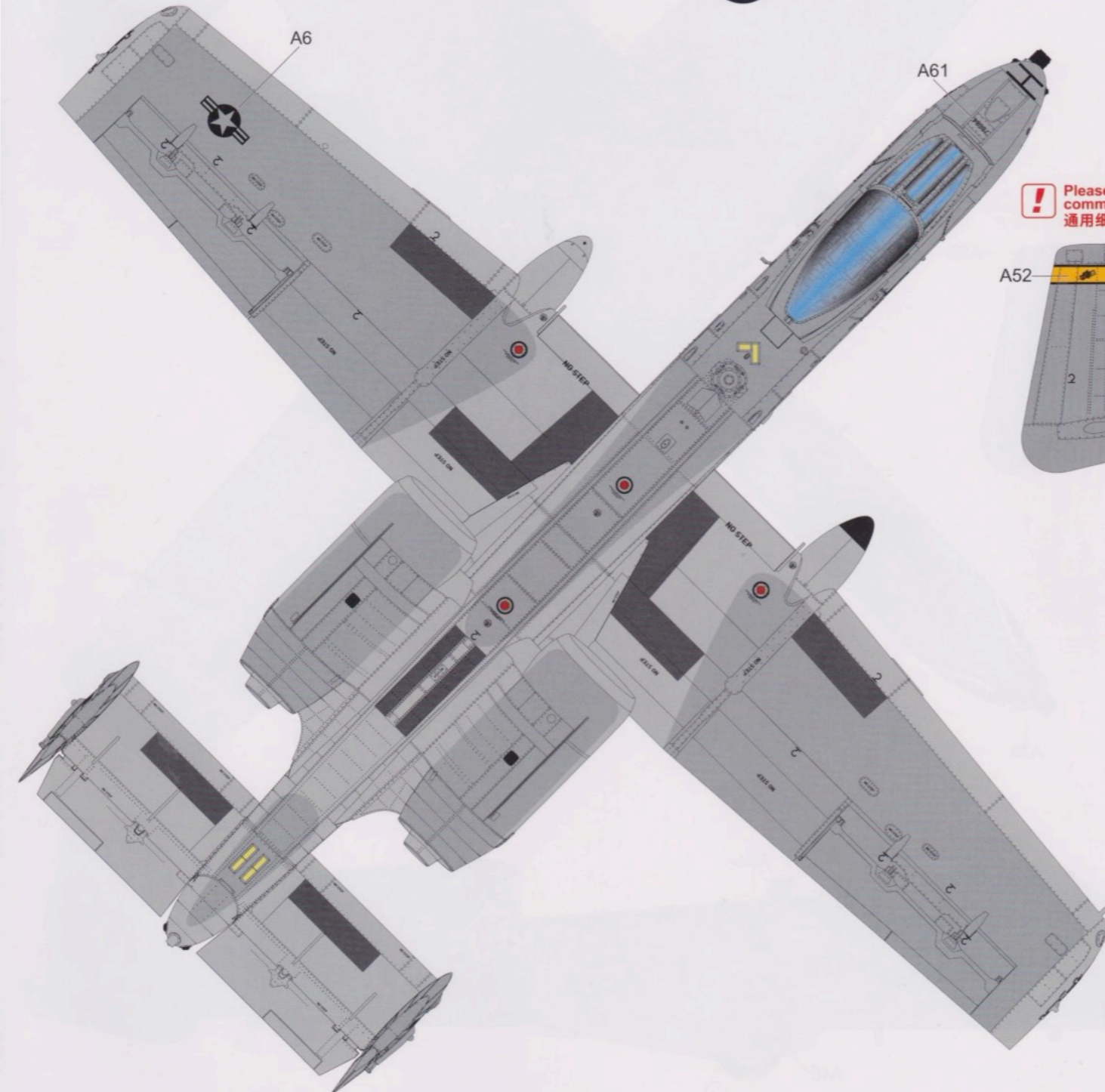
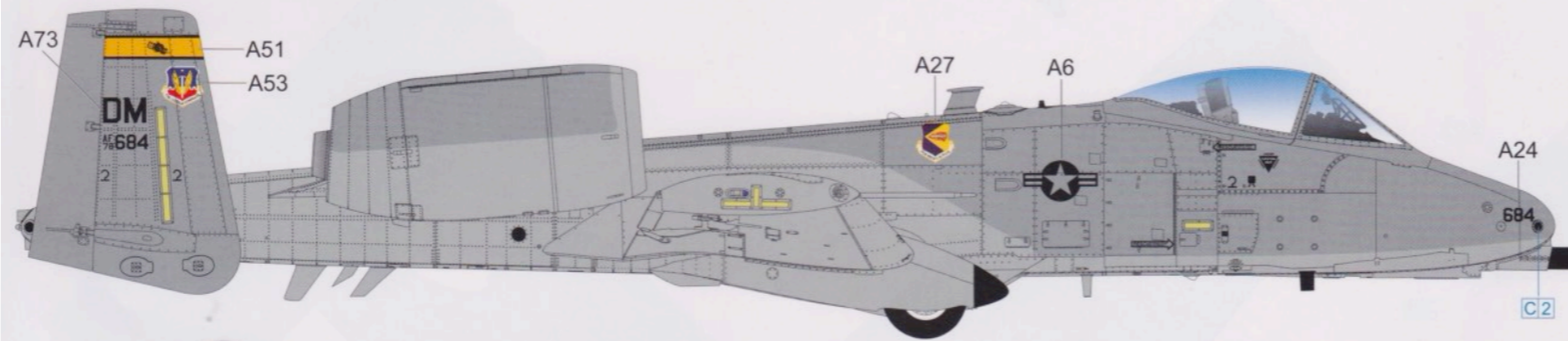

! Please refer to scheme A for colour chart on common details, unless instructed specifically
通用细节颜色漆号请参考涂装A, 除非单独标注

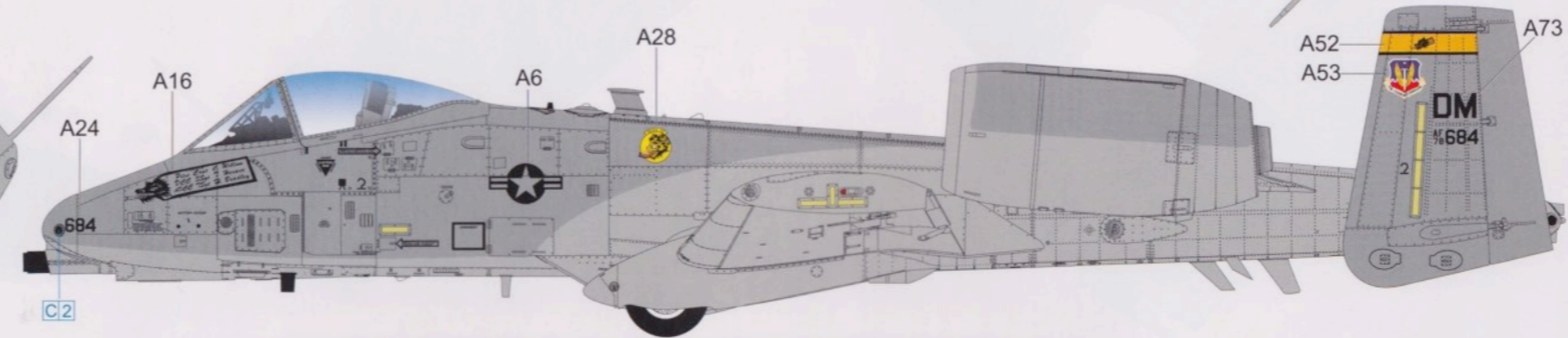
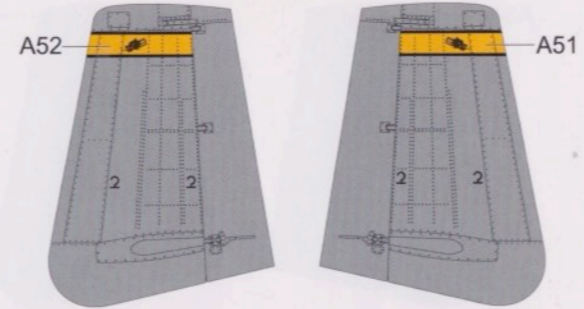



A-10C THUNDERBOLT II

雷電二式 近距离支援攻击机
CLOSE AIR SUPPORT ATTACK AIRCRAFT

1/48 SCALE AIR CRAFT L4829
涂装指示 PAINTING マーキングと塗装図



D 80-0194 74th Fighter Squadron, "Flying Tigers", 23rd Wing, Langley AFB, USAF, 2011
80-0194 美国空军 第23联队 74战斗机中队 "飞虎队" 兰利空军基地 2011

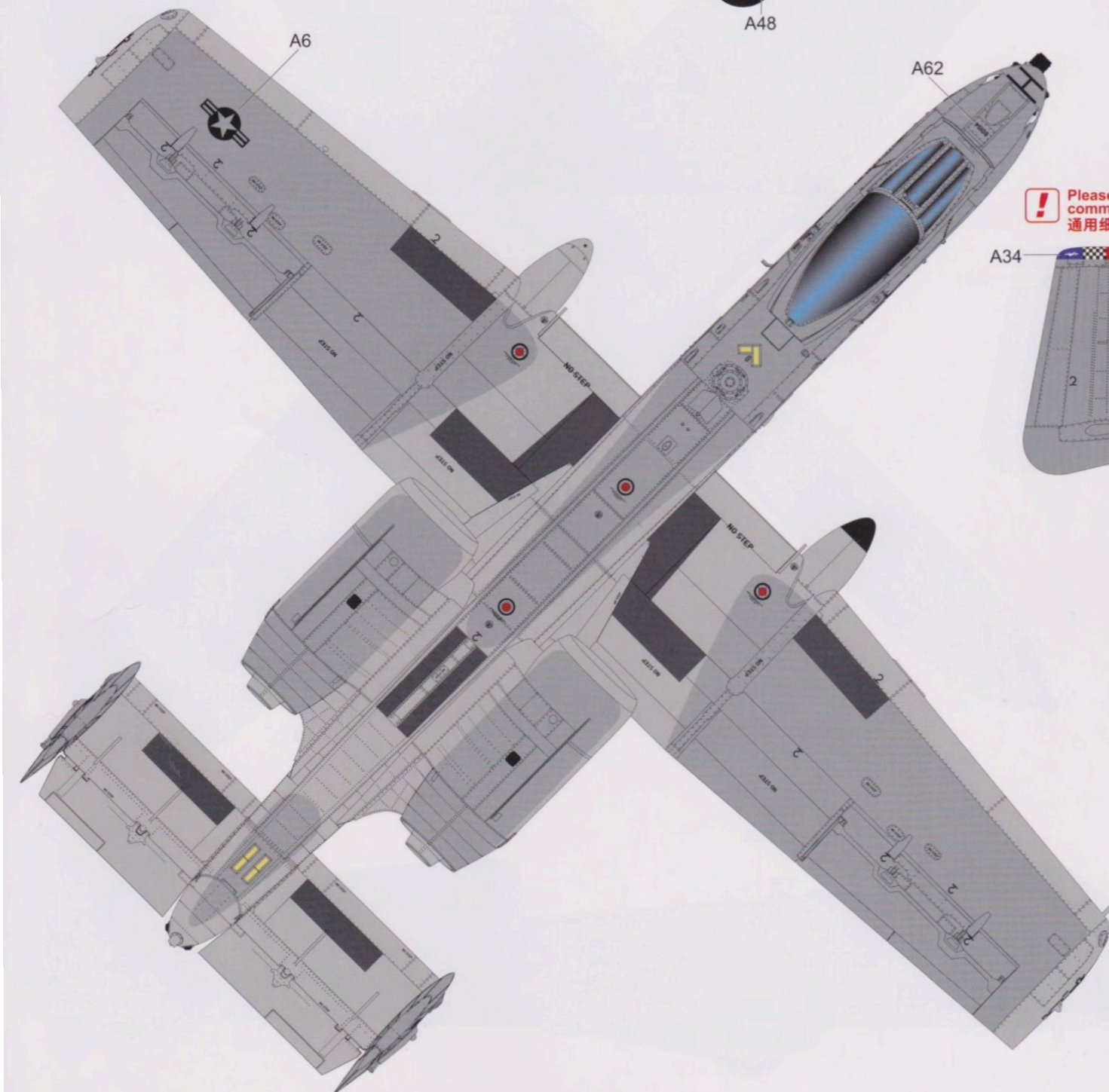
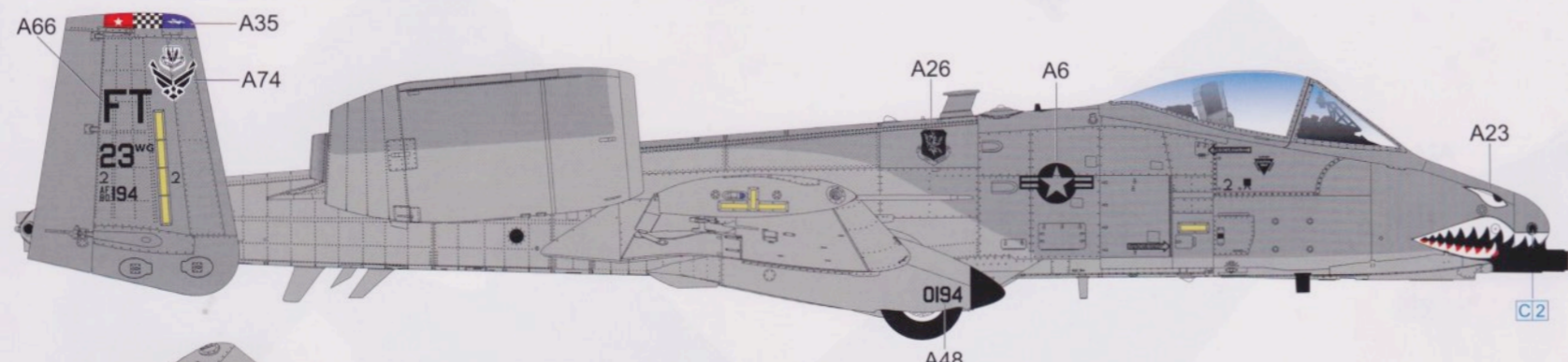

! Please refer to scheme A for colour chart on common details, unless instructed specifically
通用细节颜色漆号请参考涂装A, 除非单独标注

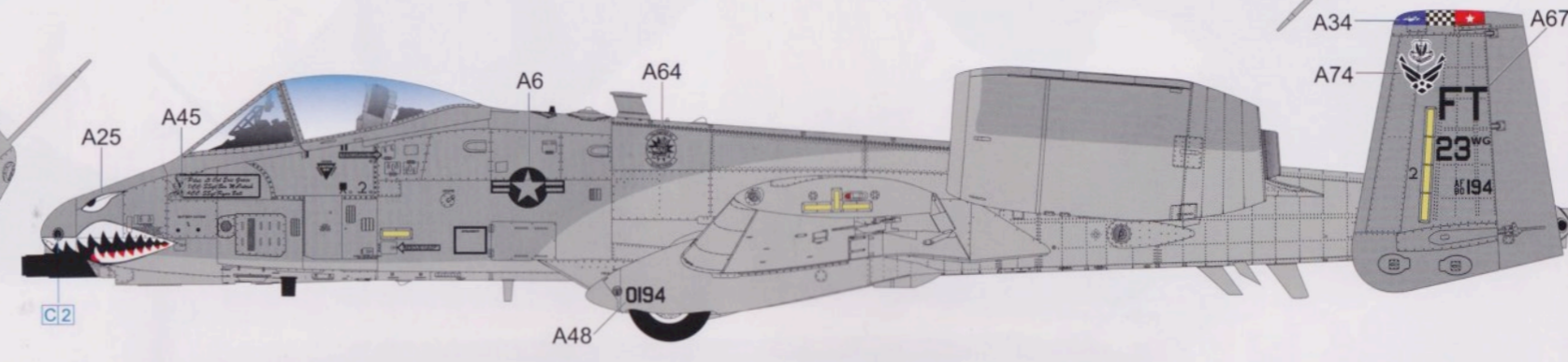
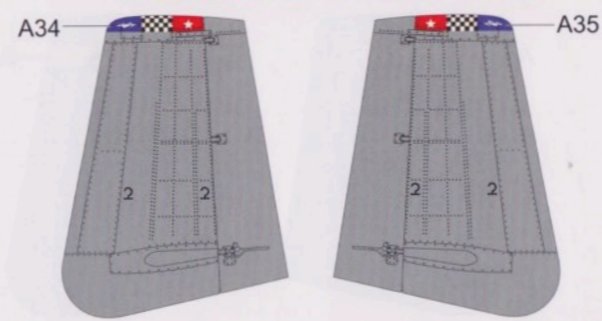



A-10C THUNDERBOLT II

雷電二式 近距离支援攻击机
CLOSE AIR SUPPORT ATTACK AIRCRAFT

1/48 SCALE AIR CRAFT L4829
涂装指示 PAINTING マーキングと塗装図



E 80-0283 25th Fighter Squadron, 51st Fighter Wing, Osan AB, PACAF, USAF, 2016
80-0283 美国空军 太平洋空军 第51战斗机联队 25战斗机中队 乌山空军基地 2016

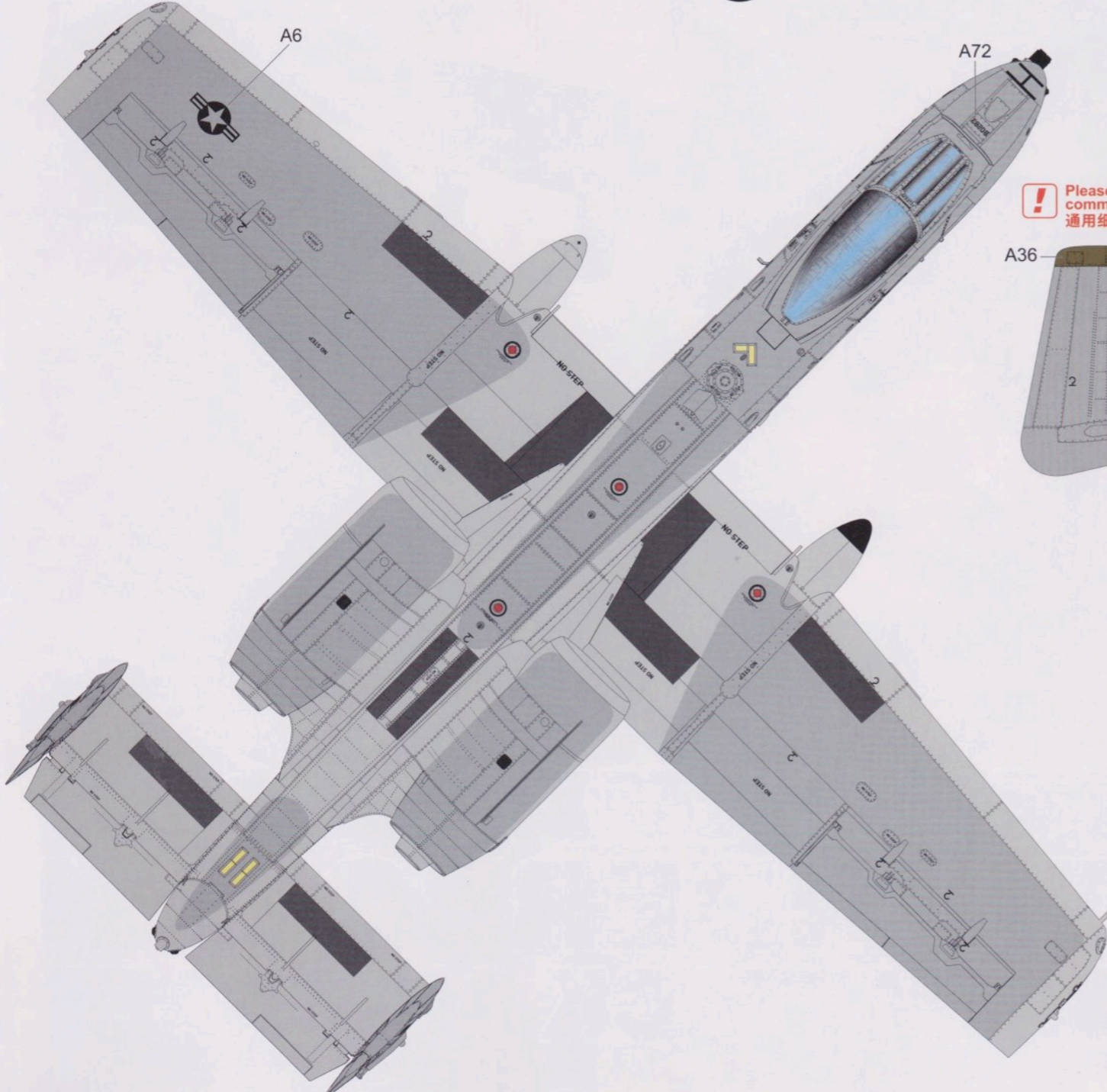
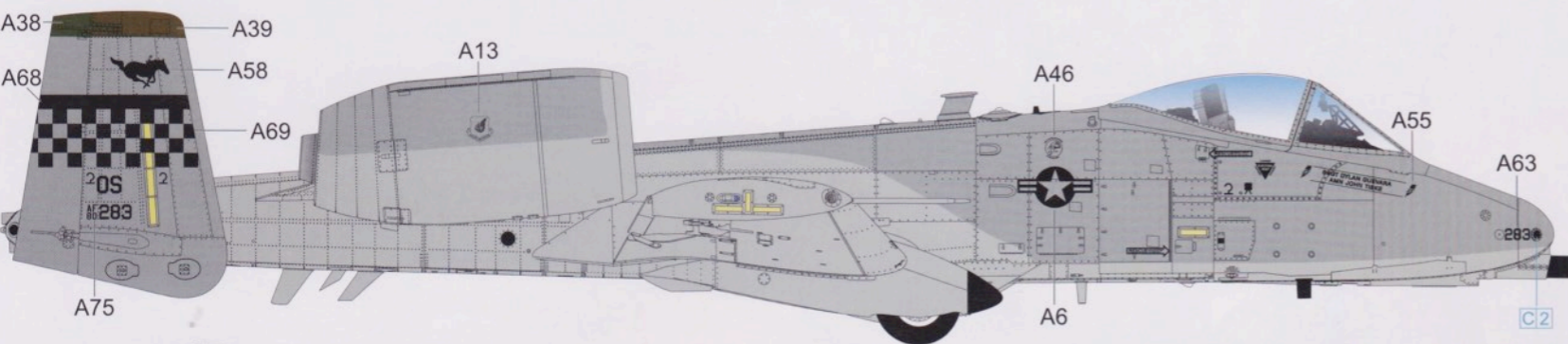

! Please refer to scheme A for colour chart on common details, unless instructed specifically
通用细节颜色漆号请参考涂装A, 除非单独标注

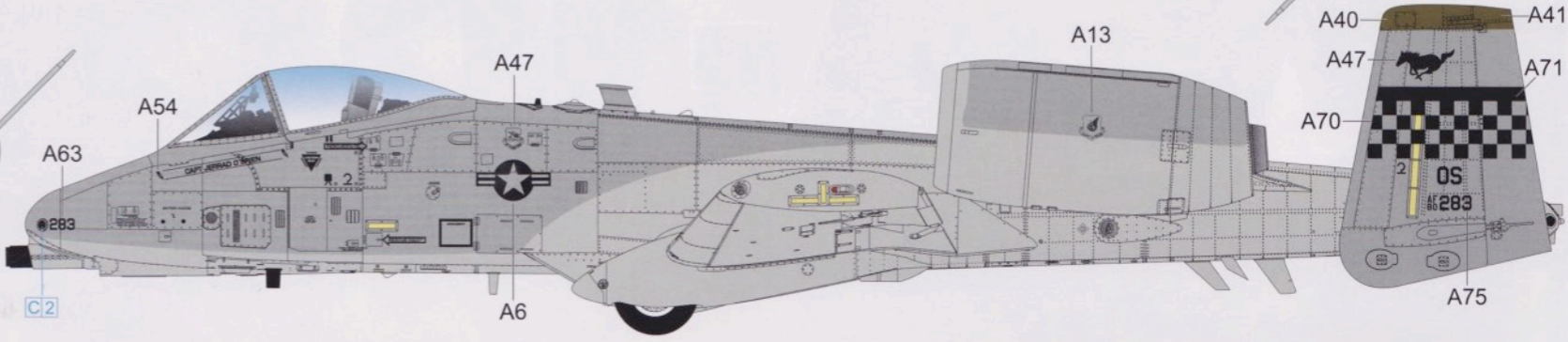
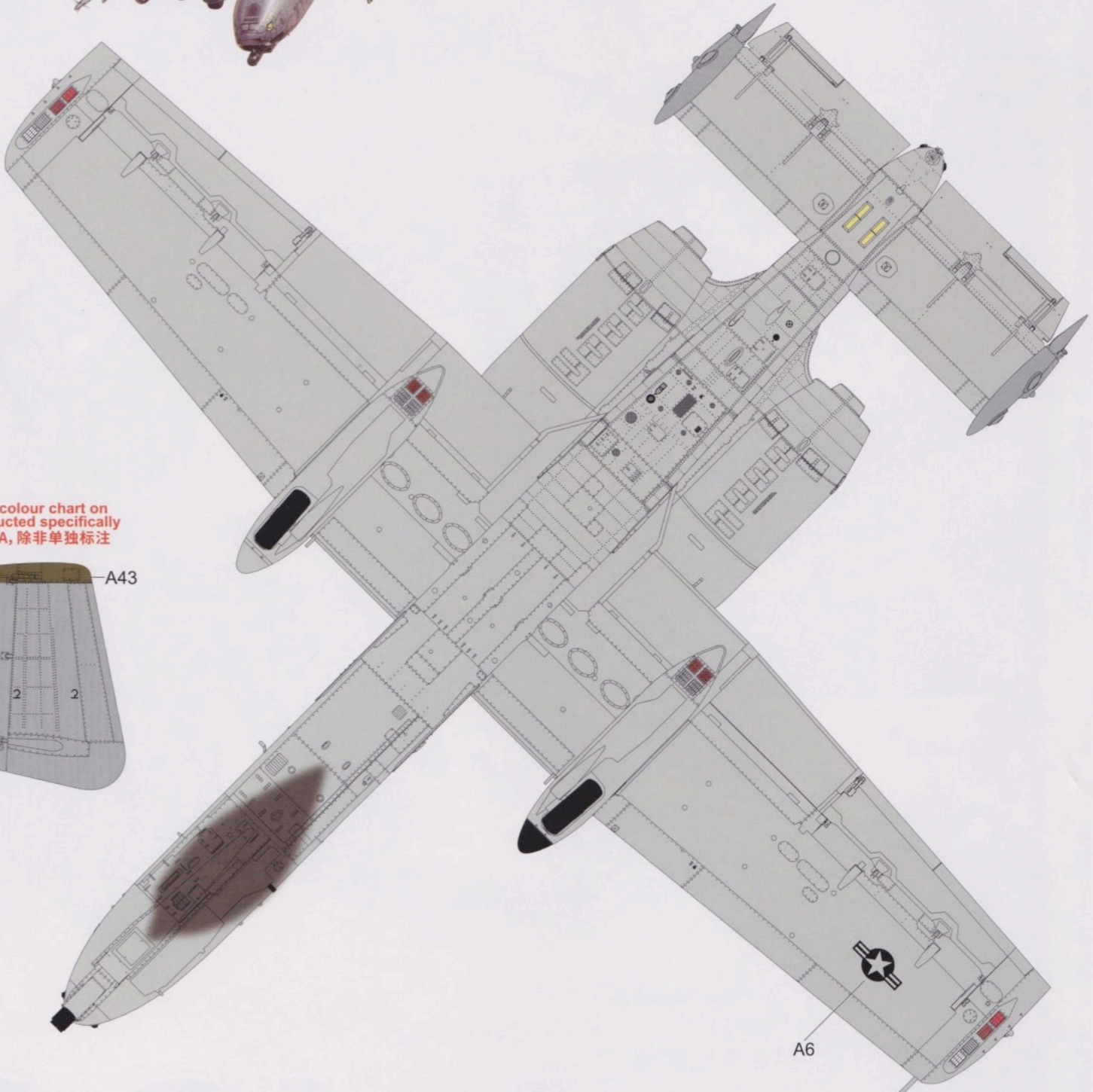
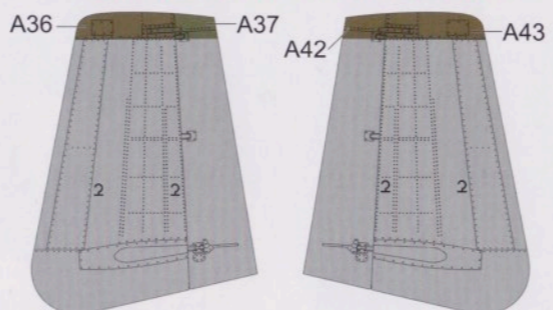

G.W.H.[®]

1/48
SCALE
L4829



A-10C 雷電二式 近距离支援攻击机
THUNDERBOLT II
CLOSE AIR SUPPORT ATTACK AIRCRAFT

