

RUSSIAN TANK T34/76

1942 PRODUCTION MODEL

1/35 MILITARY MINIATURES SERIES

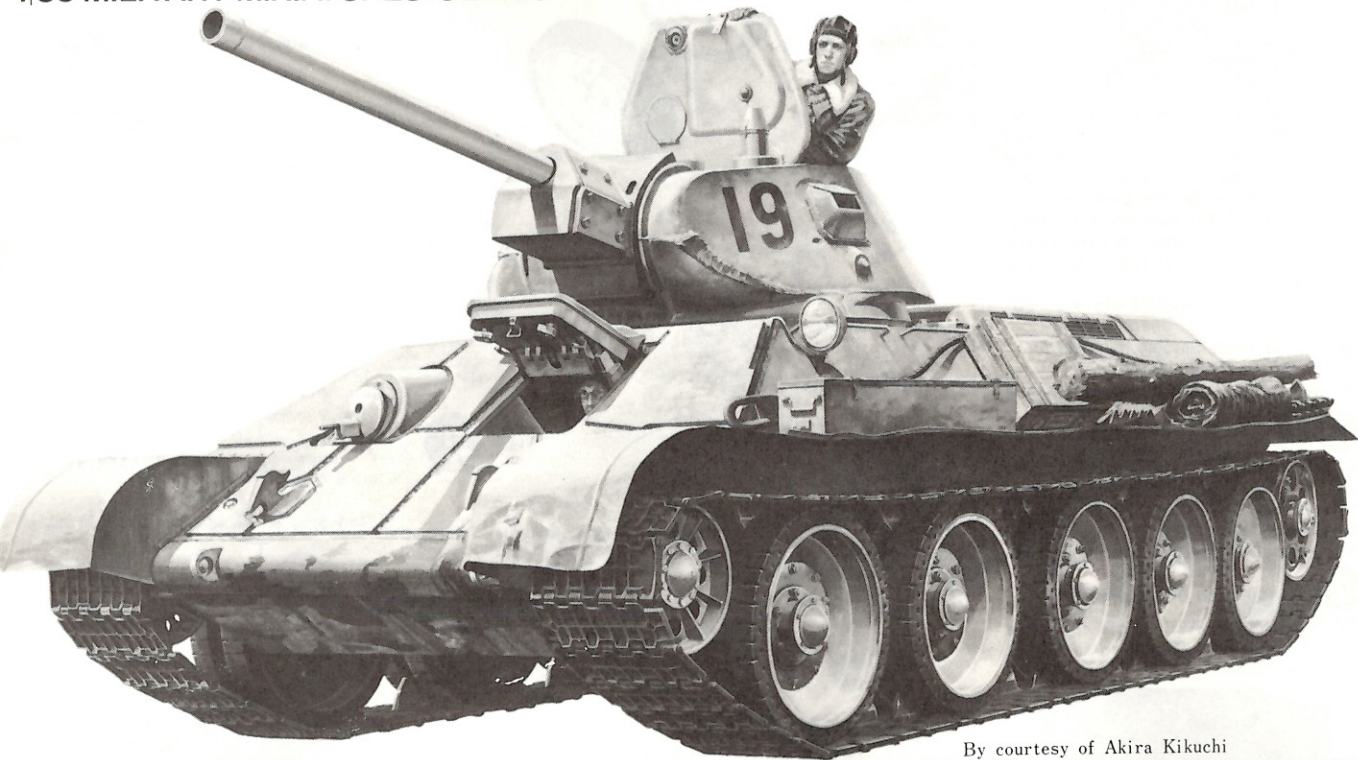

By courtesy of Akira Kikuchi

Soon after the beginning of Operation Barbarossa (campaign against the Soviet Union), intelligence officers in the operation room of the Supreme Commander of the Wehrmacht (OKW) received papers in succession which reported German victory over the Russians. The officers going through the papers looked full of self-confidence and men operating typewriters were elated with the victory. Everything in the room seemed to be lighted up with joy. They found strange characters "T-34" in all of the papers they received but did not know what the three characters really meant. The "T-34" contained a grievous cry of fear and distress that German tank officers and men who struggled and died on the field raised from the bottom of their heart. Now, the story goes back to the 1930's in the Soviet Union. Recognizing the need of tank forces, Joseph Stalin and the brains of the Red Army decided to develop high-speed light tanks and attacking heavy tanks after the example of the United Kingdom that had acquired a position as a leader in the theory regarding tanks and tank tactics. The Russian authorities introduced into this idea the "Operation Plan 1919" of Fuller who was said to be a genius in tank tactics.

As part of the plan, the Russian authorities bought in 1931 two Christie tanks from the United States. They found the peculiar invention created by this eccentric American usable as a basis of their new high-speed tanks. Thus were born Russian BT tanks, which developed from the first model 1 through the model 7/2 into the last BT-7M (BT-8). In the meantime, the Russians improved on the Christie

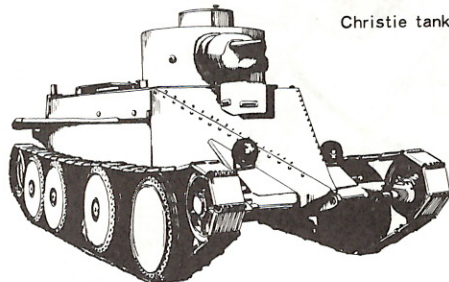

Christie tank

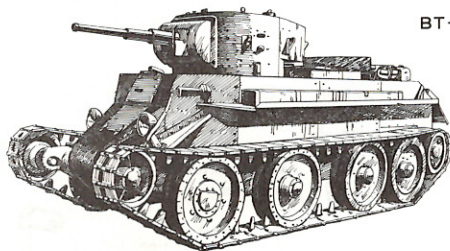

BT-5

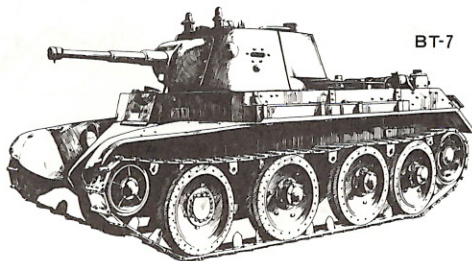

BT-7

suspension which had proved to have some disadvantageous points, and repeatedly put it to practical tests.

The shape and construction of the BT tanks indicated the basic design of Russian tanks to be developed later. The features of the BT tanks included sloping armour plates on the body, characteristic cylindrical turret which projected rearward to contain projectiles, and diesel engine employed in the last model. These features were all inherited by later Russian tanks, which developed into modern tanks. The A-20 and T-32 tanks, successors to the BT tanks, were designed by a team which consisted of M.E. Koshkin who served as chief designer and young, able engineers from the Leningrad Technical Institute who ranked beside Kotin, designer of the KV tank. In 1938, Koshkin's design team was ordered to design a new medium tank. Unlike the A-20 and T-32 which used both wheels and tracks, the new tank was to be a full-track fighting vehicle. It was to have a weight of 25 tons, armour thickness of 45 mm maximum, 76.2 mm main gun, Christie-type suspension, and Russia's proud V-2 diesel engine which proved successful in the BT-7M.

Design work was completed as early as the beginning of 1939, because in basic points the team had only to follow the design of the T-32 which they previously made.

From the end of 1939 to 1940, the Russian authorities put the pilot model to severe tests including the well-known winter 3,600 km trial run. Thereafter the new medium tank T-34 was officially accepted for production and appeared as one of the important weapons to decide the

Formation of Russian Tank Brigade (as of 1942)

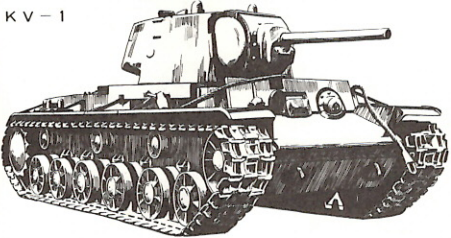
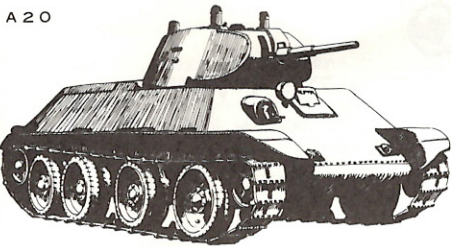

fate of World War II. In the meanwhile, the design team met with a misfortune. Chief designer Koshkin, the pillar of the team, died of tuberculosis at the age of 42 in the prime of life. This was because he worked too hard. His machines, however, ran about the mother earth of Russia and saved the motherland by destroying the invading forces. They contributed toward remaking the map of Europe after the war.

The victory of the T-34 owed much to a combination of the priority principle which the designers basically followed to facilitate production and the unique production system that producers employed.

The T-34 was the very fighting machine. No contemporary tank of other nations had so small number of parts as the T-34. Of course, no other tank had unnecessary parts, but the T-34 had reduced the number of necessary parts by unifying them under happy ideas.

To cite an instance, pins connecting track links together had no cotter pin or clasp. This was made possible by a bright idea. Connecting pins shaped like long bolts were inserted from inside (body side) to hold track links together, but they were liable to come off because of the rough movement of the tank. To prevent it, an ingenious device was used. A semicircular guide plate fixed over the rear end of each track near the

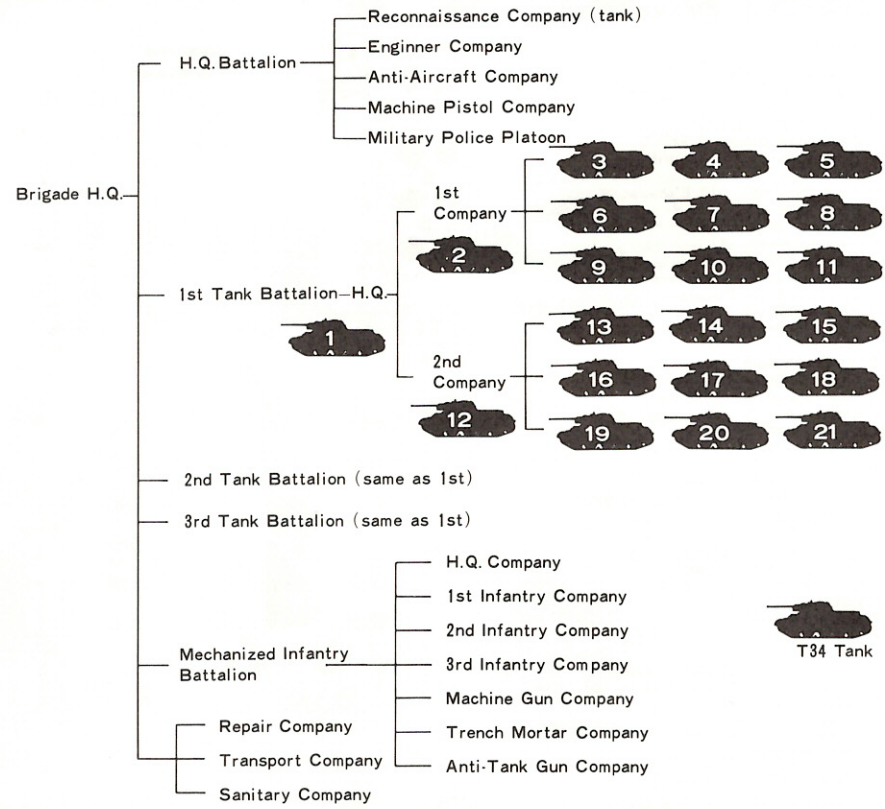

sprocket wheel was designed to automatically push back connecting pins which were coming out of the rotating track. Such happy ideas were found also in other details.

In reply to the efforts of the designers, Russian production engineers developed new production processes with "More and Faster" as their motto. One of them was "chilled casting" which took the place of conventional sand-mould casting. The chilled casting employed metal moulds and could be called a kind of die casting. It was used in making large castings for the diesel engine, the heart of the T-34 tank. This process, unlike the sand-mould casting, required little skill which could be attained in a very short time.

Also, large presses were employed to stamp out armour plates for the T-34 tank. They were able to stamp iron plates with thickness of up to 45 mm and produced mainly turret roofs and side armour plates in large quantities. These production processes were based upon the Russian priority principle and symbolic of thorough-going Slavic rationalism.

On the other hand, the V2-34 diesel engine, the heart of the T-34 tank, compared favourably in precision with engines manufactured in West Europe. German engineers were surprised at the precision of the diesel engine when they inspected captured T-34 tanks. It is said that they took their hat off to Russian engineers who made parts of light aluminium alloy used in some components of the diesel engine.

The tank gun which constituted the main armament of the fighting vehicle was the best one in those days. The high-velocity 76.2 mm gun was originally 30.5 calibres long but later became 41.2 calibres long and much improved in performance. The gun was able to penetrate 54 mm armour plate at a distance of 1,600 metres.

The T-34 tank was the product of Slavic rationalism. It was powered by the excellent engine, armed with the powerful gun and protected with stamped thick armour plates welded onto the body in a rather unsightly manner. Thus the T-34, unlike West European tanks, did not have polished shape at all. It, however, was superior in fighting power to any tank then manufactured by any other nation of the world. The T-34 was a real fighting vehicle and great tank.



PARTS

A

Shadowed parts are accessory parts.

27 & 31 are unnecessary.

C

(A PARTS)

1. Cylindrical Tanks (Upside)
2. Cylindrical Tanks (Underside)
3. Rear Intake (Right)
4. Rear Intake (Left)
5. Periscope Cover (Left)
6. Periscope Cover (Right)
7. Rear Panel
8. Tool Box (A)
9. Tool Box (B)
10. Exhaust Pipes
11. Hull Rear Cover
12. Machine Gun Mount
13. Towing Hook (A)
14. Towing Hook (B)
15. Cylindrical Tank Covers
16. Exhaust Pipe Covers
17. Antenna Base
18. Hull Handrails (A)
19. Hull Handrails (B)
20. Spare Tracks
21. Front Adjustment Part
22. Rear Panel for Display
23. Light (A)
24. Light (B)
25. Final Gear Covers
26. Driver's Hatch
27. Unnecessary
28. Spare Tracks (B)
29. Driver's Hatch Part
30. Wire Ropes
31. Unnecessary

(B PARTS)

1. Bogie Wheel Caps
2. Drive Sprocket Cap
3. Hull Joint Part
4. Idler Wheel Caps
5. Unnecessary

(C PARTS)

1. Rubber-Tyred Bogie Wheels (A)
2. Rubber-Tyred Bogie Wheels (B)
3. Idler Wheels (A)
4. Drive Sprockets (A)
5. Drive Sprockets (B)
6. Idler Wheels (B)

(D PARTS)

1. Turret Hooks
2. Gun Barrel Tip
3. Gun Barrel
4. Commander's Upper Half
5. Commander's Lower Half
6. Commander's Right Arm (A)
7. Commander's Right Arm (B)
8. Commander's Left Arm
9. Gun Shield Cover
10. Turret Front Cover
11. Turret (Top Plate)
12. Gun Shield (Left)
13. Gun Shield (Right)
14. Gun Shield (Front)
15. Turret Rear Panel
16. Cannon Drum
17. Turret Hatch
18. Turret (Right)
19. Turret (Left)
20. Seat (Left)
21. Seat (Right)
22. Turret Handrails (A)
23. Turret Handrails (B)

(E PARTS)

1. Steel-Tyred Bogie Wheels (A)
2. Stowage Boxes
3. Track Attachment
4. Blanket Rolls
5. Driver's Left Arm
6. Driver's Right Arm
7. Driver's Body
8. Loading Section (Right)
9. Loading Section (Left)
10. Periscope
11. Driver's Figure Holder
12. Steel-Tyred Bogie Wheels (B)
13. Hull Handrails (C)
14. Angular-Shaped Tank (C) (Left)
15. Angular-Shaped Tank (C) (Right)
16. Angular-Shaped Tank (B)
17. Saddle
18. Breech Protection Plate
19. Angular-Shaped Tank (A) (Right)
20. Angular-Shaped Tank (A) (Left)
21. Extra Welded-on Armour Plate
22. Tool Case
23. Shovel (B)
24. Shovel (A)
25. Logs

*Shadowed parts in the drawings should not be fixed to the basic style of this T-34 model. They are optional parts, so fix them and assemble various models as shown in the latter part of instruction sheets.

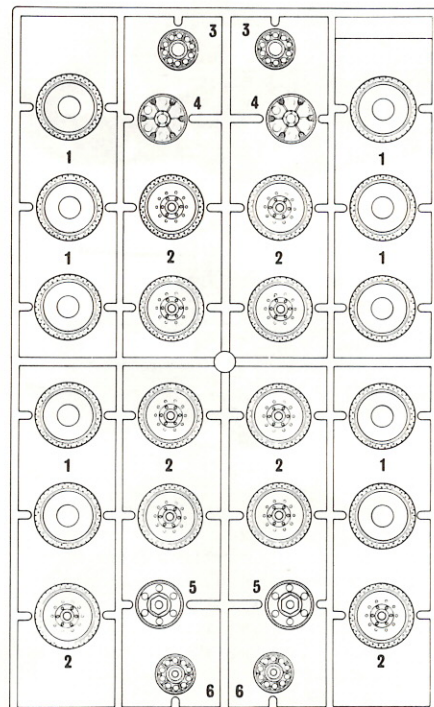
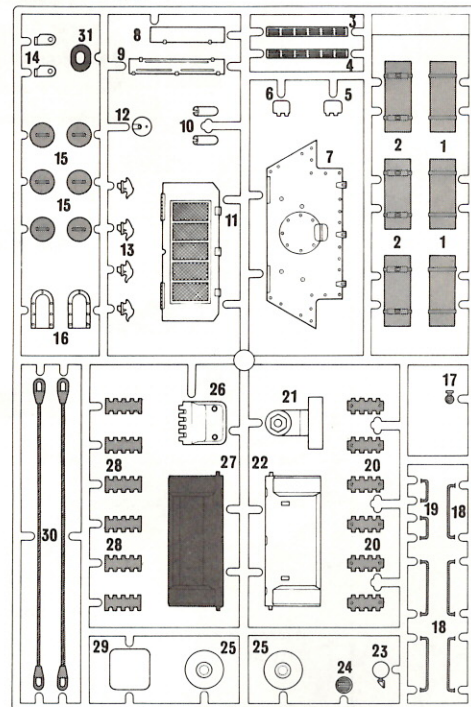

Shadowed parts are accessory parts.

B

B5's are unnecessary.

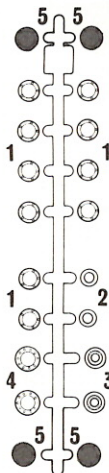

D

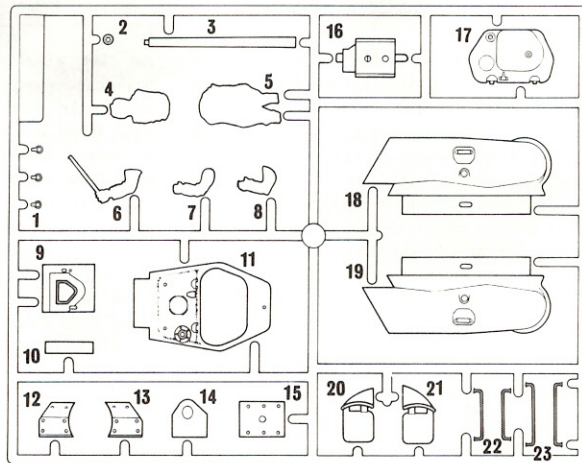

E

Shadowed parts are accessory parts.

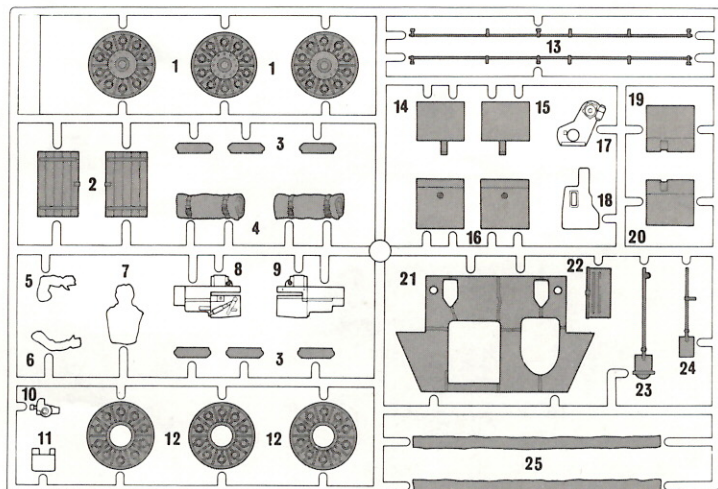

7 (Completion of Basic Style)

Complete the basic model as shown in the figure. Photographs showing Accessories are given on the next page. Complete the T-34/76 with reference to the photographs and your additional material or your preference.

(Construction of Tracks)

Touch pin heads lightly with heated nail (with wood handle).

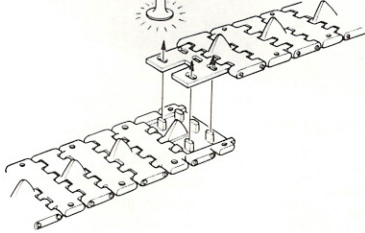

(Construction of Figures)

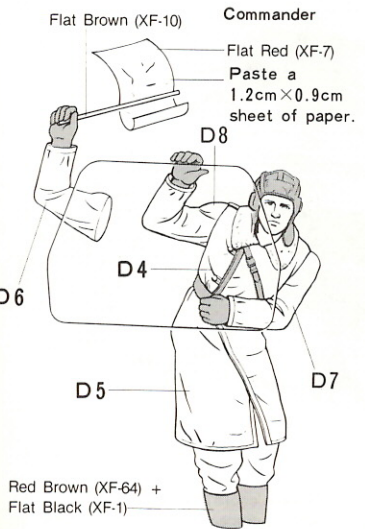
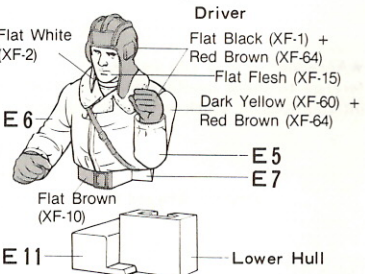

★Slight mark of folds on flag may add cloth-like reality.

7 Completion of Basic Style

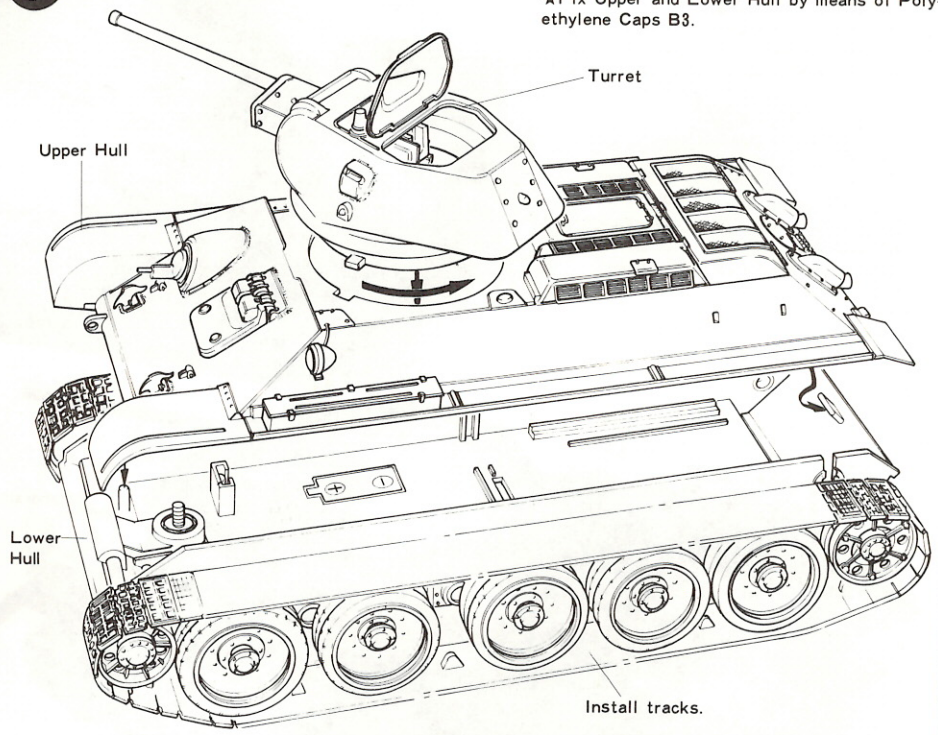

★Fit pins on Turret to the cutted portions of Hull as in the figure, and turn to fix.
★Fix Upper and Lower Hull by means of Polyethylene Caps B3.

Photo of Completed Basic Style



(Construction of Fuel Tanks)

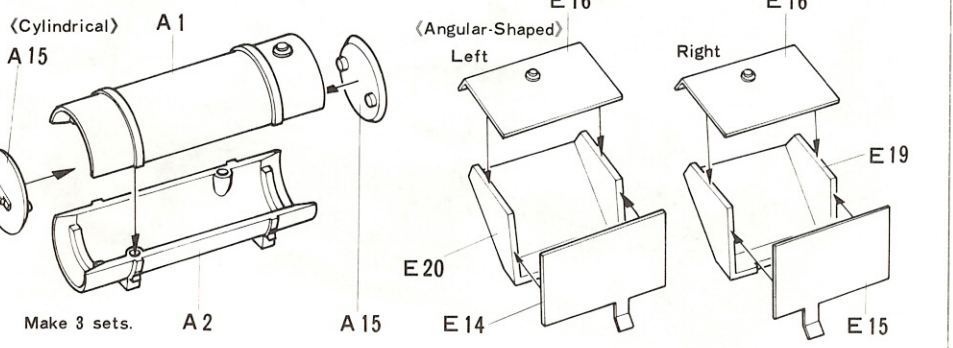

(Construction of Fuel Tanks)
Additional fuel tanks were mounted to increase the cruising range of the tank. They were cylindrical or square in shape.

★Accessory Parts are shown in the photographs on page 7. Fixing of Accessory Parts, painting and marking may be done with reference to the photographs and figures in this booklet and your additional material or your preference.

<KIROV Plant Production Model>

★This model was manufactured by plants in Gorki, Leningrad and Kirov and used mainly in the Leningrad area. It was characterized by an extra sloping armour plate fixed on the front.

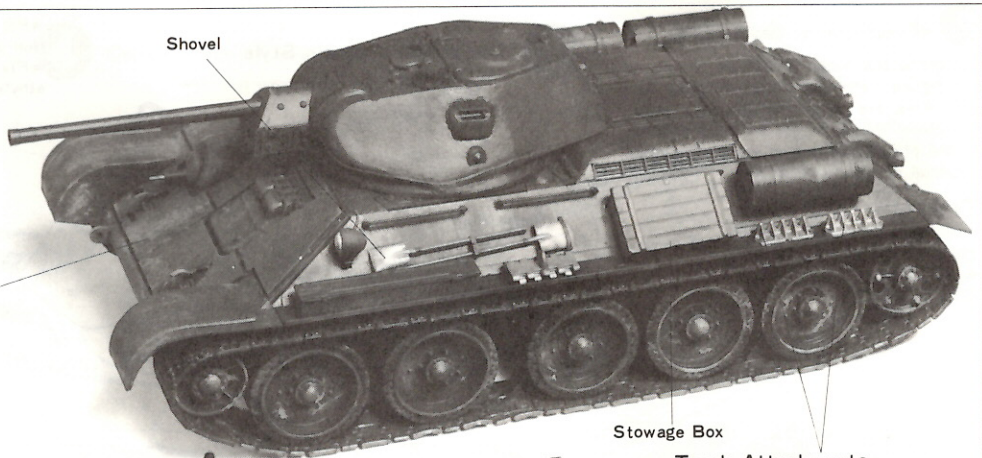

Shovel

Extra Sloping Armour Plate

To cope with German guns which improved in performance, the additional sloping armour plate was fixed on the front.

Remove the parts shown in the figure at the bottom of page 4 and cement the armour plate in position.

Storage Box

Track Attachments

These were fixed to the tracks to avoid slip on frozen ground. They worked in the same way as the spike tyres of a motorcar.

Cylindrical Fuel Tank

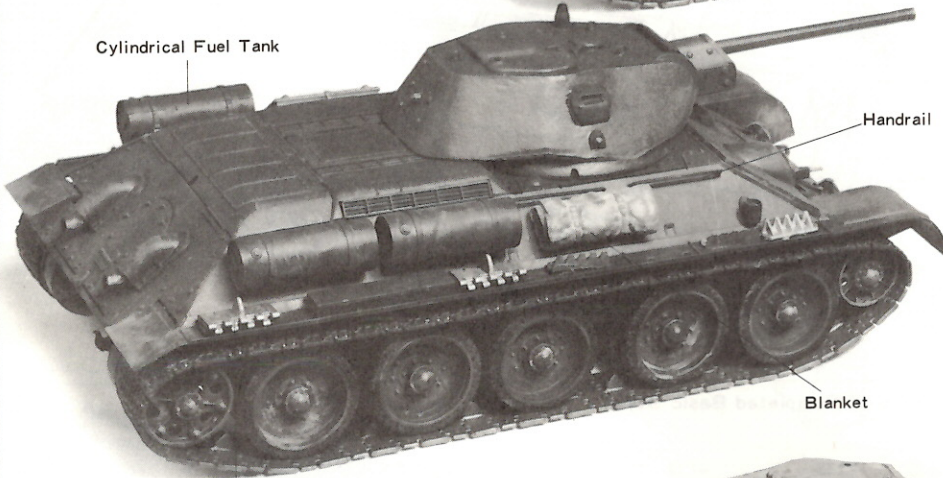

Handrail

★Accessory Parts may be fixed with reference to these photographs and your informations in stock or your preference.

Spare Track

Angular-Shaped Fuel Tank

Blanket

Track Attachment

<Production Model from Second Half of 1942>

T-34/76 tanks manufactured from the second half of 1942 used cast steel-tyred wheels in place of some rubber-tyred ones because the Russians were short of rubber.

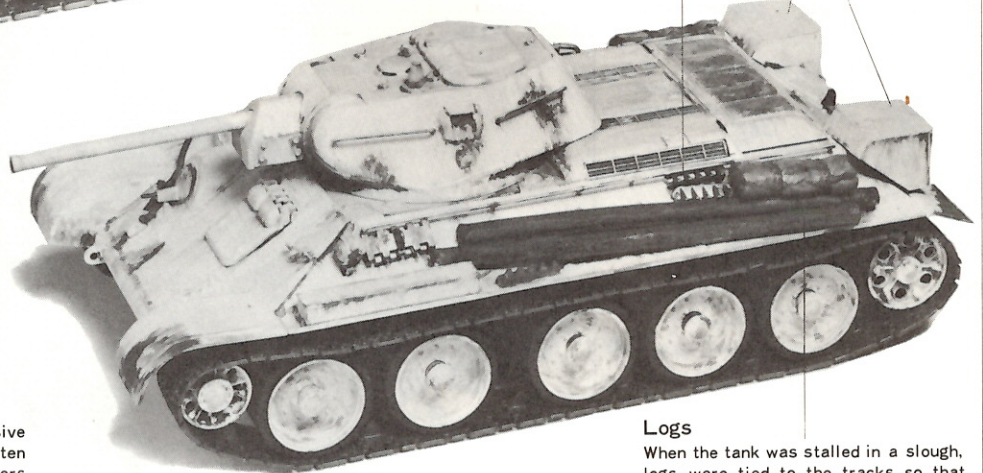

Handrails

As the Russians changed from defensive action into pursuit action, the tank often moved to the front with a number of soldiers on it. For them, handrails were fixed to various places on the tank.

Logs

When the tank was stalled in a slough, logs were tied to the tracks so that the tank could get away from it. They were indispensable to the tank in Russia at the snow-thawing season.

Blanket

Wire

Decide where to fix a wire. Bend the wire as you like by gradually warming it over a candle fire or the like and fix it.

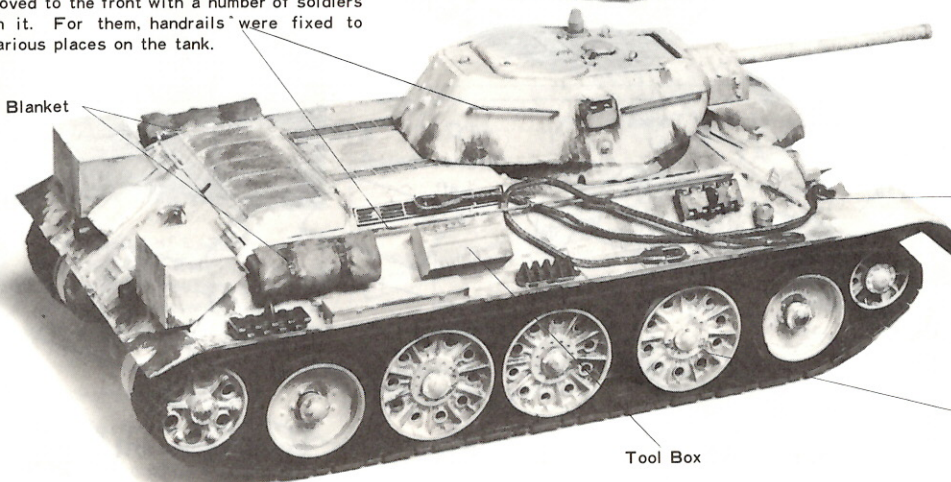

Tool Box

Steel-Tyred Bogie Wheels

In the second half of 1942, the Russians began to use cast steel-tyred bogie wheels in place of rubber-tyred ones because they were short of rubber. In view of function, cast steel-tyred ones were generally used for only three central wheels on each side. In some tanks manufactured toward the end of the war, cast steel-tyred ones had to be used for all bogie wheels.

PAINTING



APPLYING DECALS

Painting of T34/76

Russian tanks were sprayed with dark green paint overall. This was their standard painting. In seasons other than winter, camouflage was seldom seen but tanks of only a few units were camouflaged with reddish brown pattern on the dark green ground. In winter, many tanks wore camouflage of white paint or lime on the dark green ground. The white paint or lime did not completely cover the ground. It is, therefore, recommended to paint your model tank white in such a way that the dark green ground is visible in places.

COLORS REQUIRED

Tamiya Spray Colors

TS-2 Dark Green
 TS-5 Olive Drab

Tamiya Bottle Paints

X-2 White
 X-10 Gun Metal
 X-11 Chrome Silver
 XF-1 Flat Black
 XF-2 Flat White
 XF-7 Flat Red
 XF-10 Flat Brown
 XF-15 Flat Flesh
 XF-56 Metallic Grey
 XF-60 Dark Yellow
 XF-62 Olive Drab
 XF-64 Red Brown

Winter Camouflage

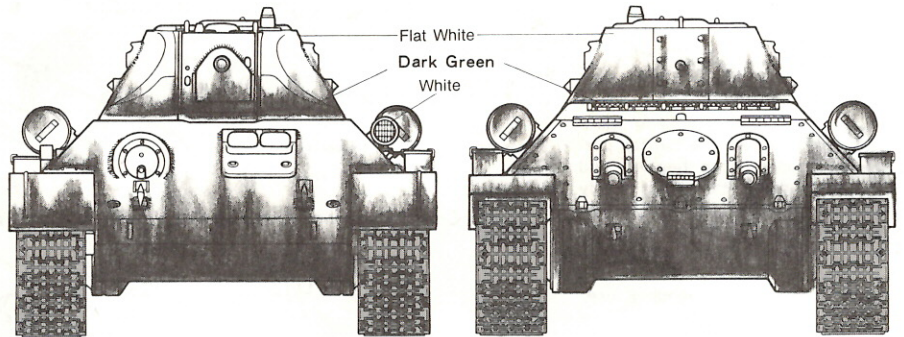
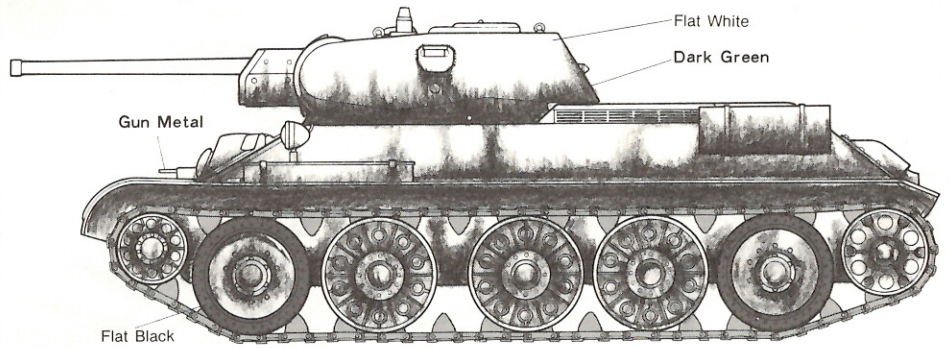

Position of Marks

Marking Which Shows Vehicle Number

★In nearly all cases, the last digit of this marking indicated the vehicle number of the tank. There existed numbers 1 to 21.

or



This indicates that the tank is No.4 vehicle. Also "64" means the No.4 vehicle, and "6" is presumed as "dummy number".

White decal on Dark Green
 Black decal on Flat White

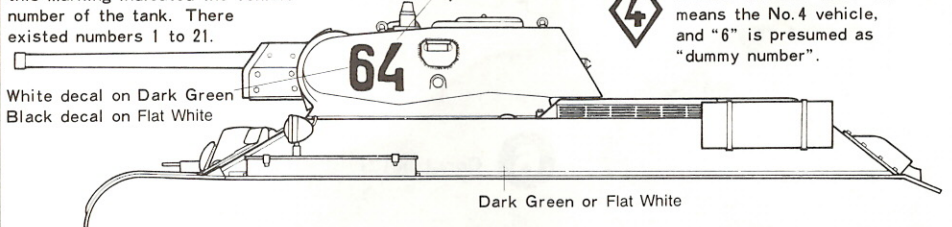

Marking Which Shows Slogans

For Fatherland

This mark shows battalion and regiment.



Dark Green or Flat White

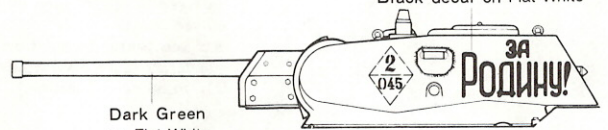

For Stalin

★The slogans "For Fatherland" and "For Stalin" were seen mainly on the tanks in the former part of the war.

Dark Green

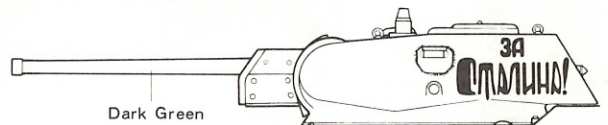

"For Soviet Estonia"

★This is a slogan that appeared toward the end of the war. Many of such slogans were written not in Russian but in a language like Ukrainian. Most of them were political ones.

Dark Green or Olive Drab



Sponsor Marking

Tamovisk Kolkhoz (Tamovisk Collective Farm)

★Labourers and union members of those days clubbed together to buy tanks and planes. They wrote their names on the weapons they bought.

Flat White



TAMIYA COLOR CATALOGUE

The latest in cars, boats, tanks and ships. Motorized, radio controlled and museum quality models are all shown in full color in Tamiya's latest catalogue. English, German, French and Japanese versions available.

Like to detail your models?

Tamiya has a fine line of photo albums that will help you in the super detailing of your tank models or diorama construction. See them at your nearest Tamiya supply house, or order direct from the factory.



TAMIYA
 TAMIYA PLASTIC MODEL CO.
 3-7, ONDWARA, SHIZUOKA-CITY, JAPAN.