

POLSKI FIAT 508/III FURGON

Polish Fiat 508/III wagon

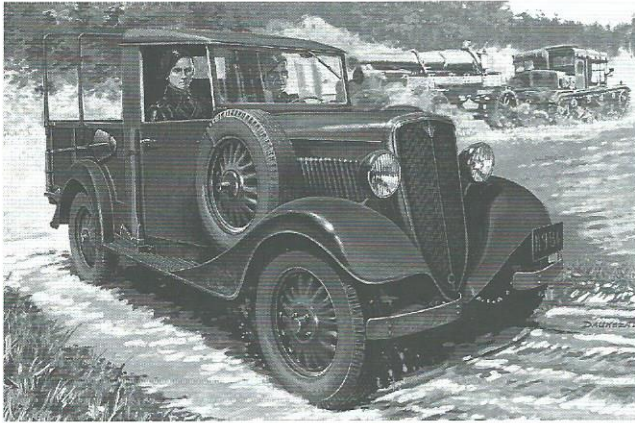











Cat. no. 72009

Scale 1/72



Project, design & artwork: Jarosław Leoniec
Research: IBG crew

		Gunze Mr.Color	Model Master Acrylic	Humbrol	Vallejo MC
black	 A	C002	4695	21	861
wood	 B	C043	4673	110	846
gunmetal	 C	C104	4681	53	863
olive green	 D	C120	4798	155	967
light grey	 E	C097	4765	196	990

-  1 Element złożony we wcześniejszym etapie
Element assembled in previous step
-  1 Element po złożeniu w aktualnym etapie
Element after assembly in actual step
-  A Kolor farby
Paint colour
-  1 Kalkomania
Decal
-  Część nie do użycia
Part not for use

Przed montażem przeczytać instrukcję. Przestrzegać kolejności montażu podanego w instrukcji! Klej i farby nie wchodzi w skład zestawu.

Please read instruction before assembly. Obey sequence of assembly like in instruction. Glue and paints not included.

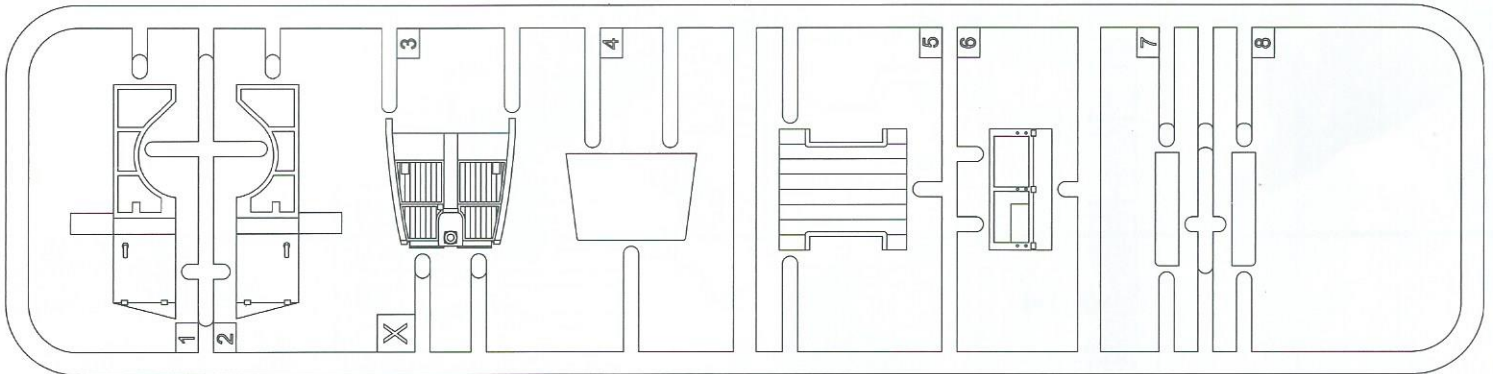

Ramka X / Frame X

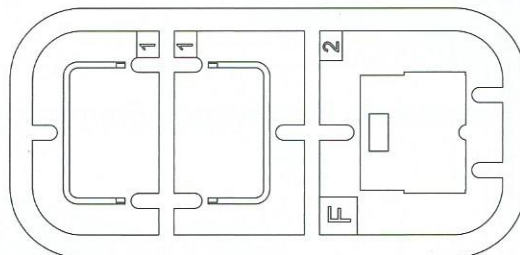

Ramka F / Frame F

International Business Group
ul. Benedykta Hertzka 2
04-603 Warszawa
Poland

tel +48 22 8159150
fax +48 22 8159151
ibgsc@ibg.com.pl
www.ibg.com.pl

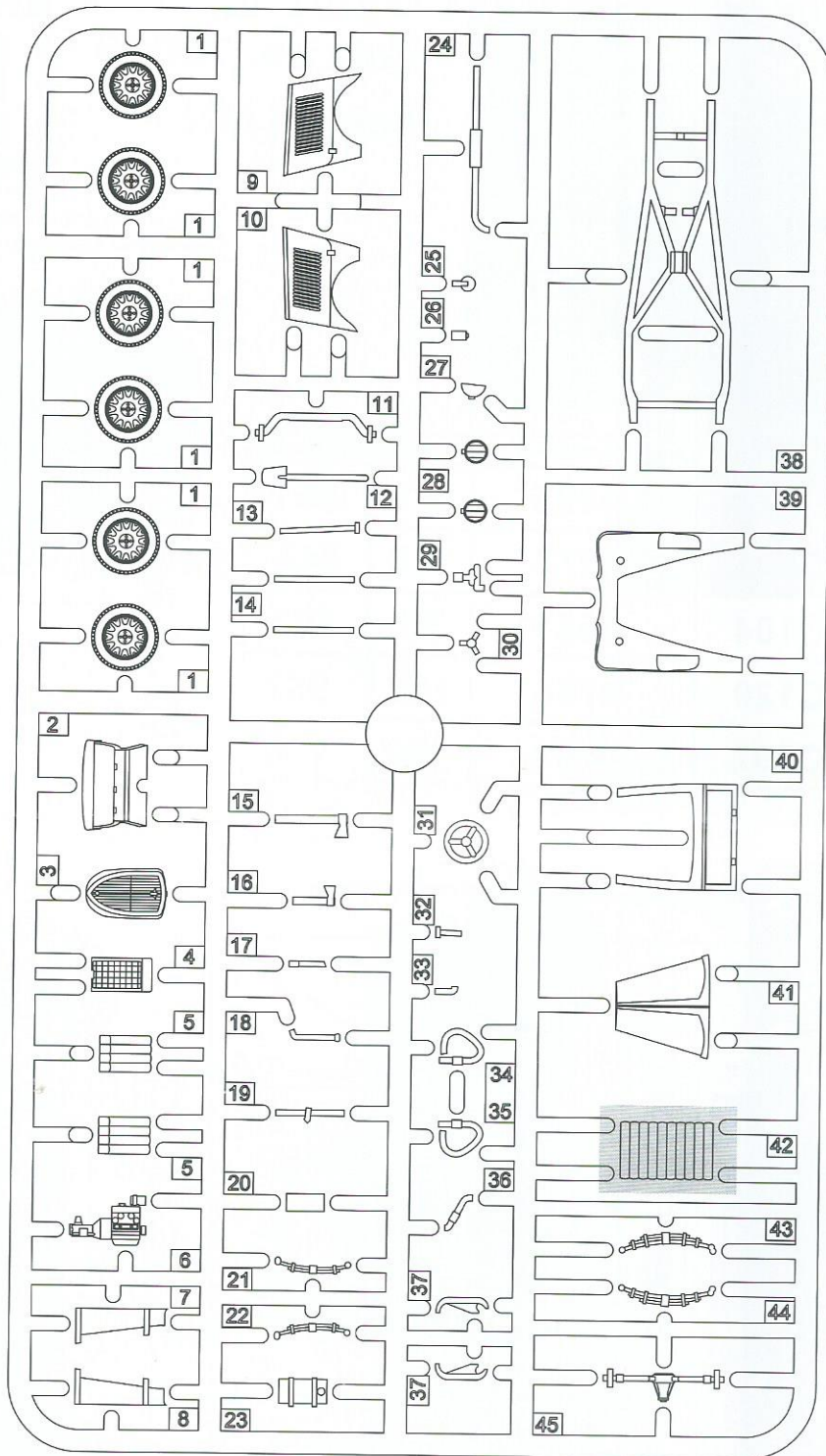

Ramka bez oznaczenia literowego / *Frame with no letter*

**ETAP 1
STEP 1**

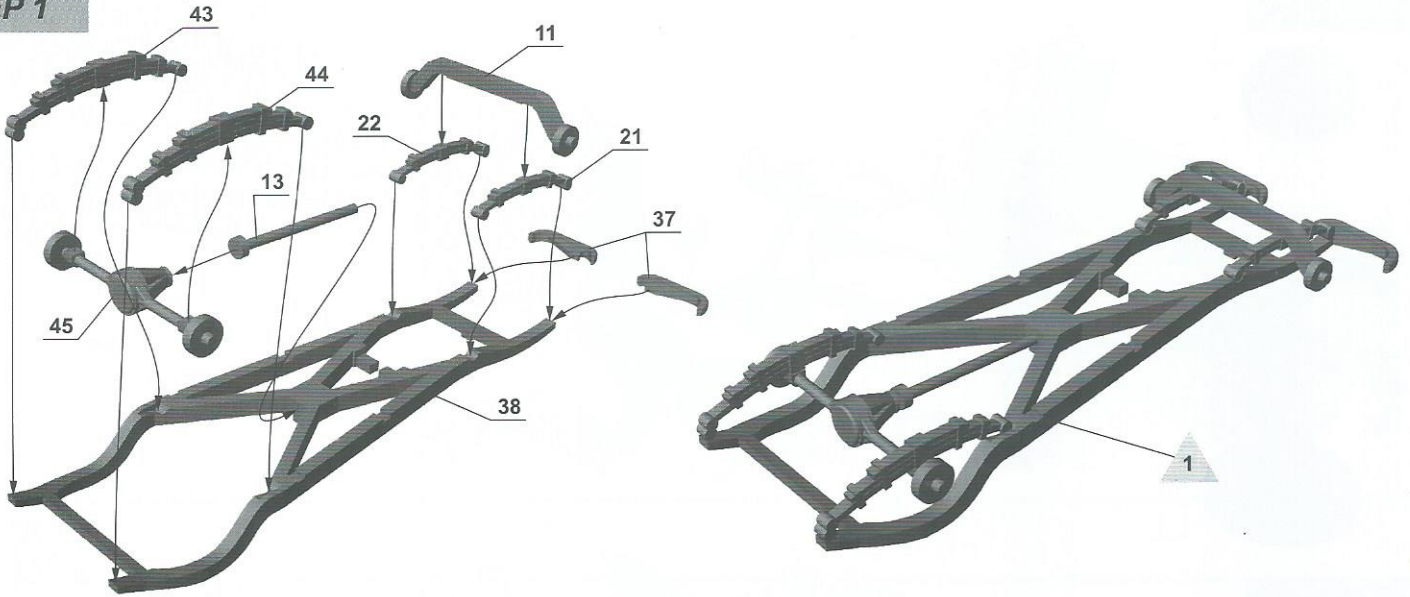

**ETAP 2
STEP 2**

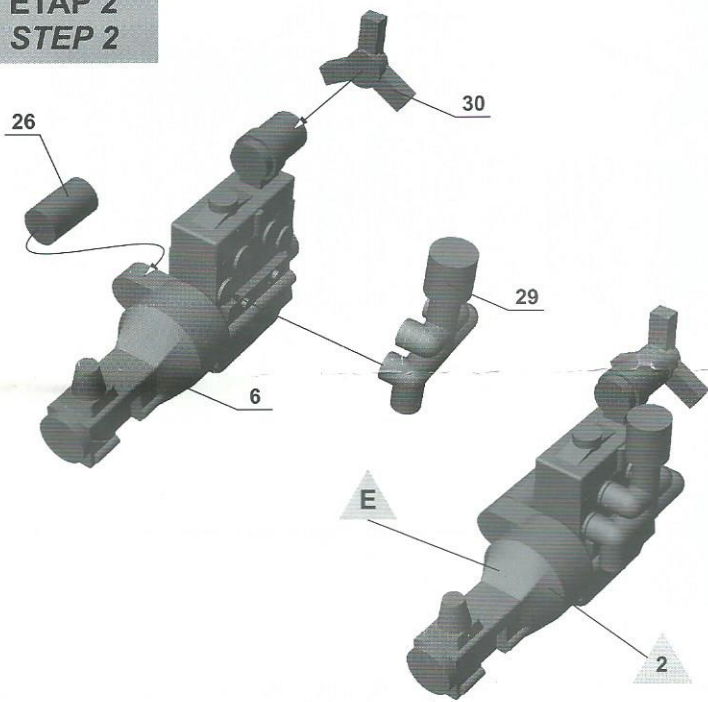

**ETAP 3
STEP 3**

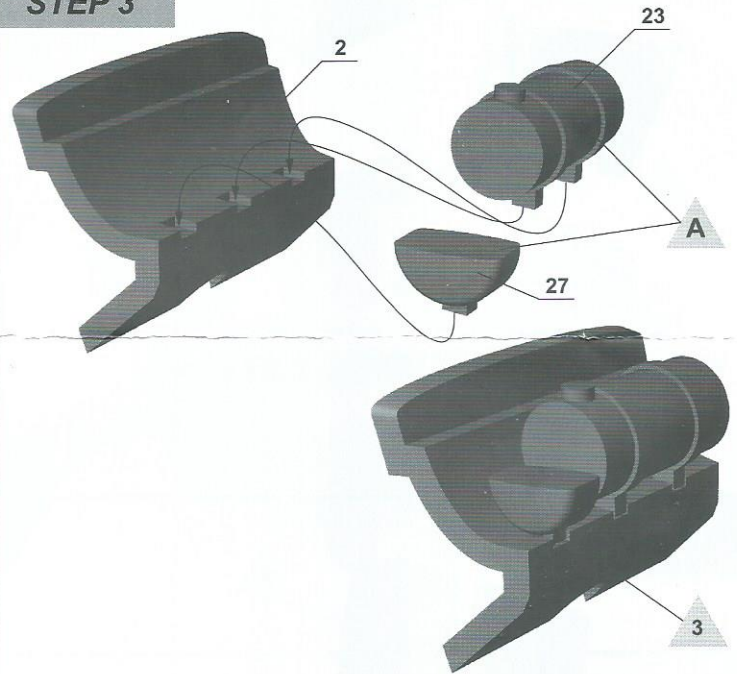

**ETAP 4
STEP 4**

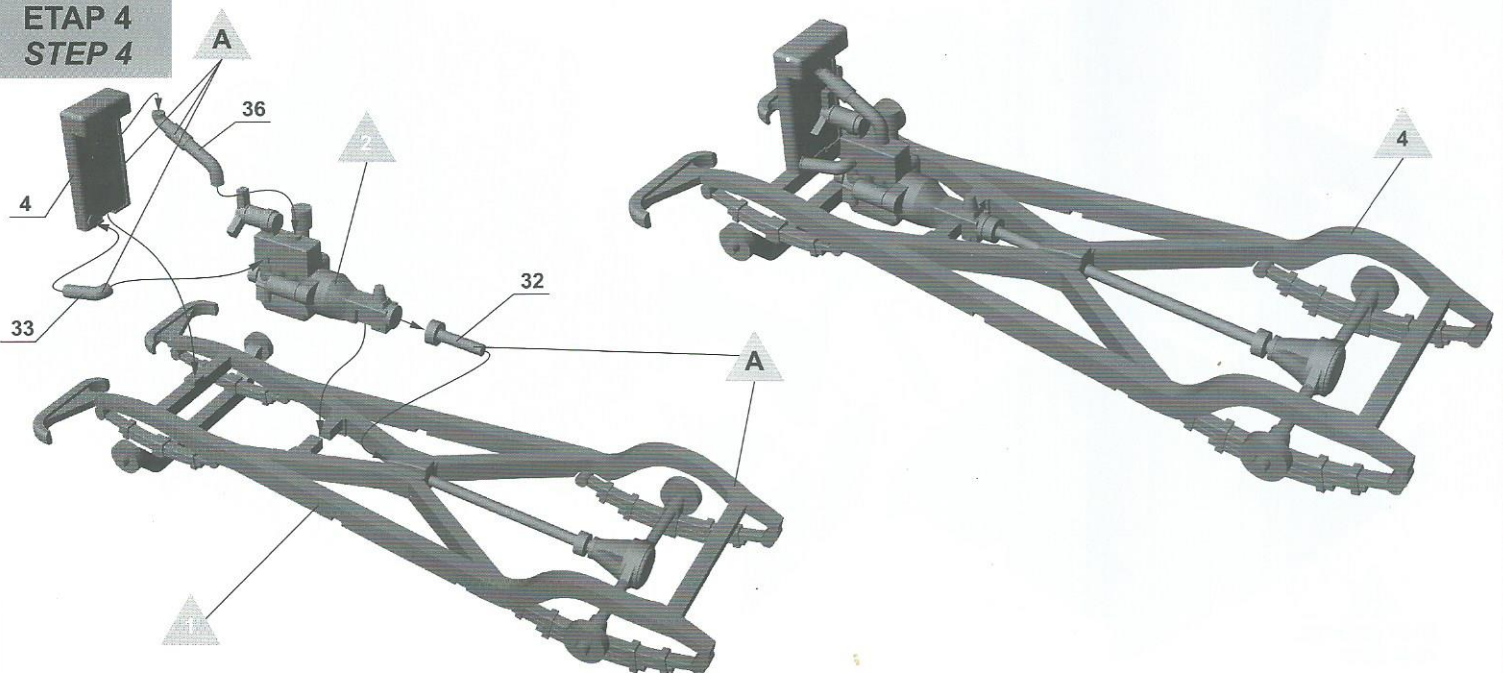

**ETAP 5
STEP 5**

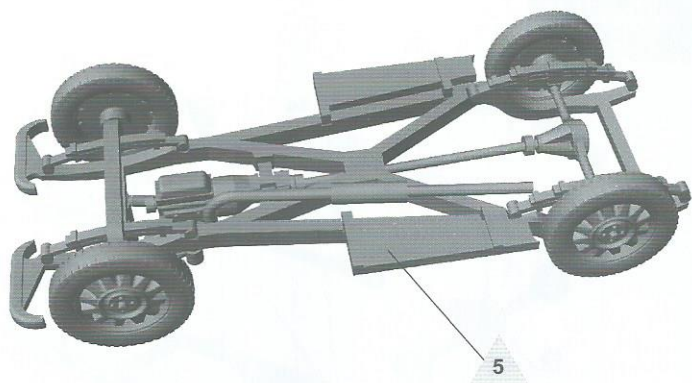
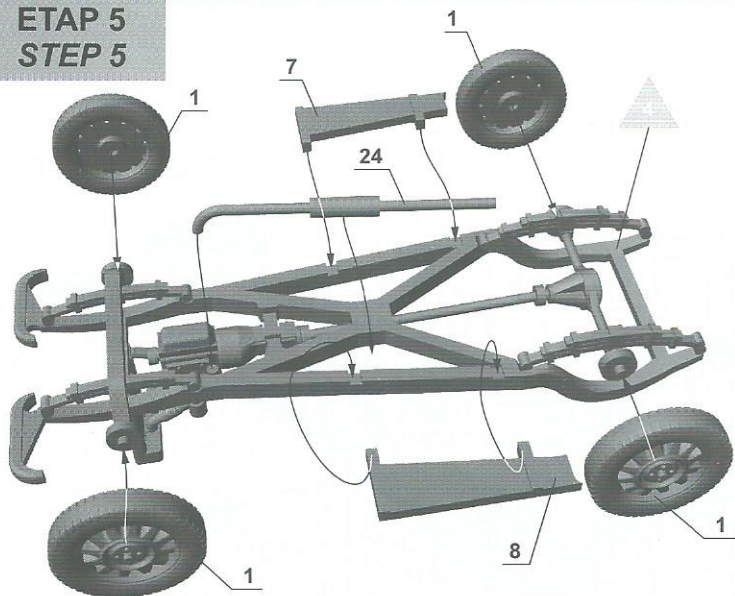

**ETAP 6
STEP 6**

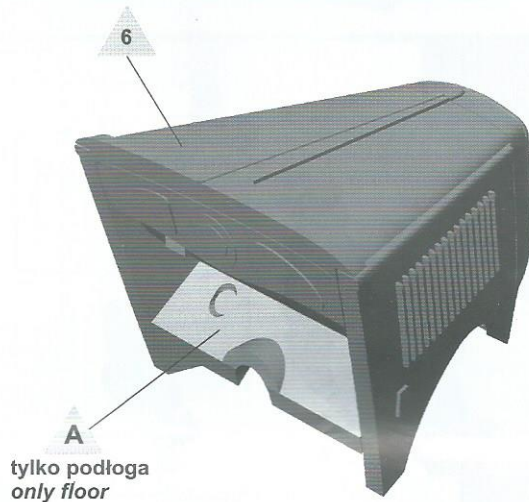
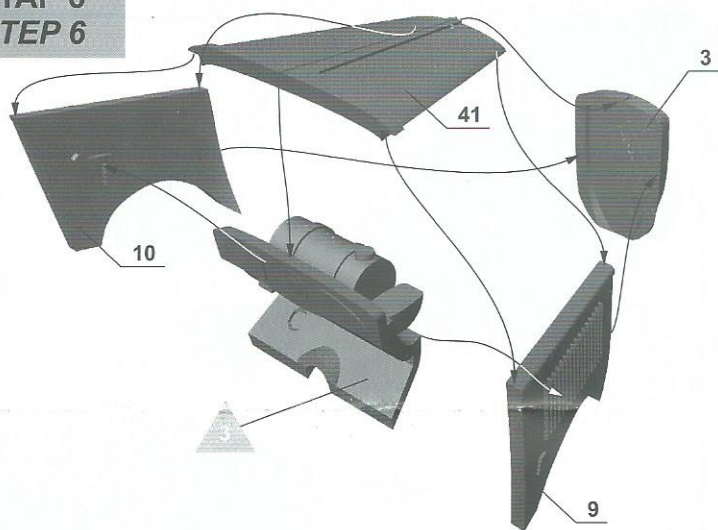

**ETAP 7
STEP 7**

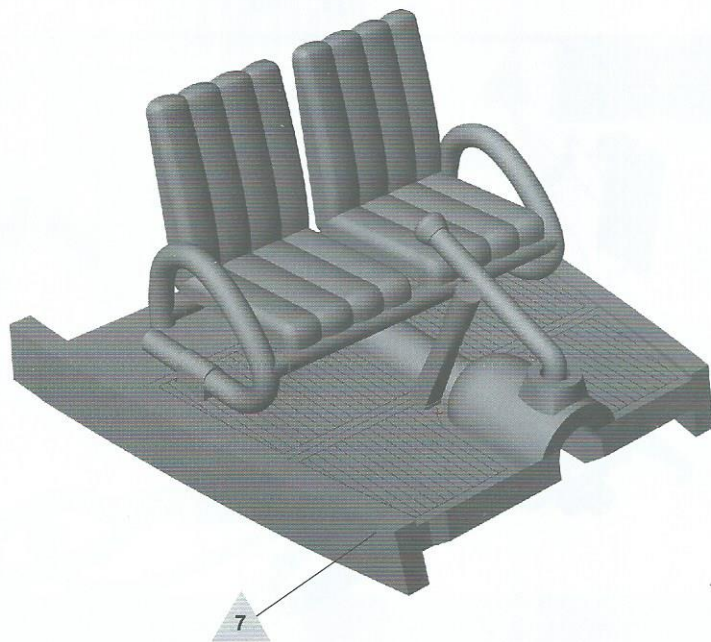

ETAP 8
STEP 8

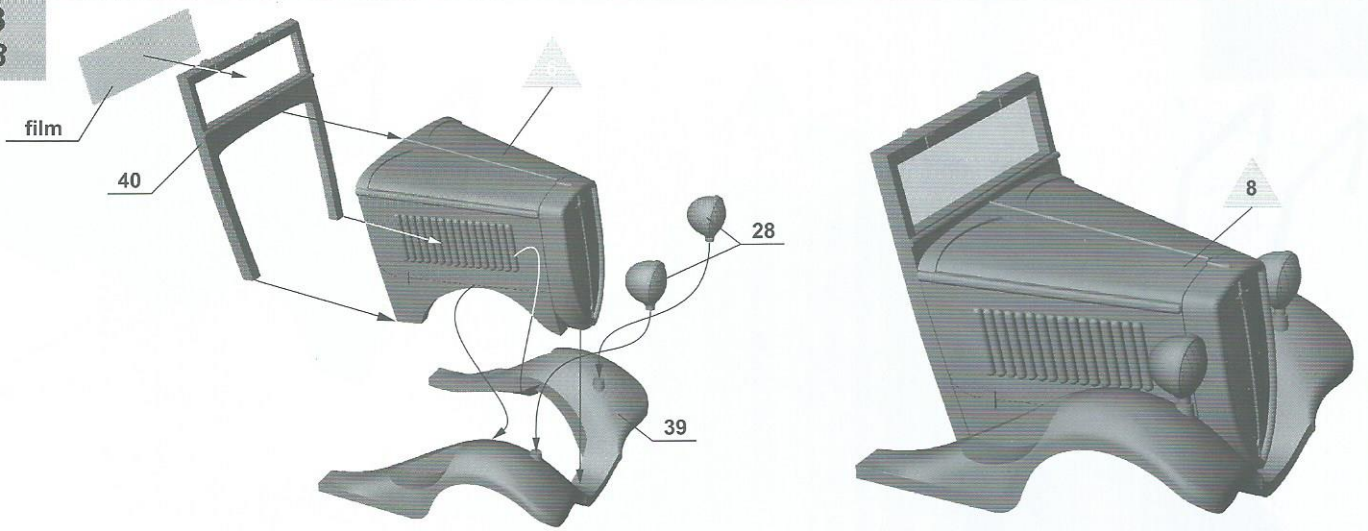

ETAP 9
STEP 9

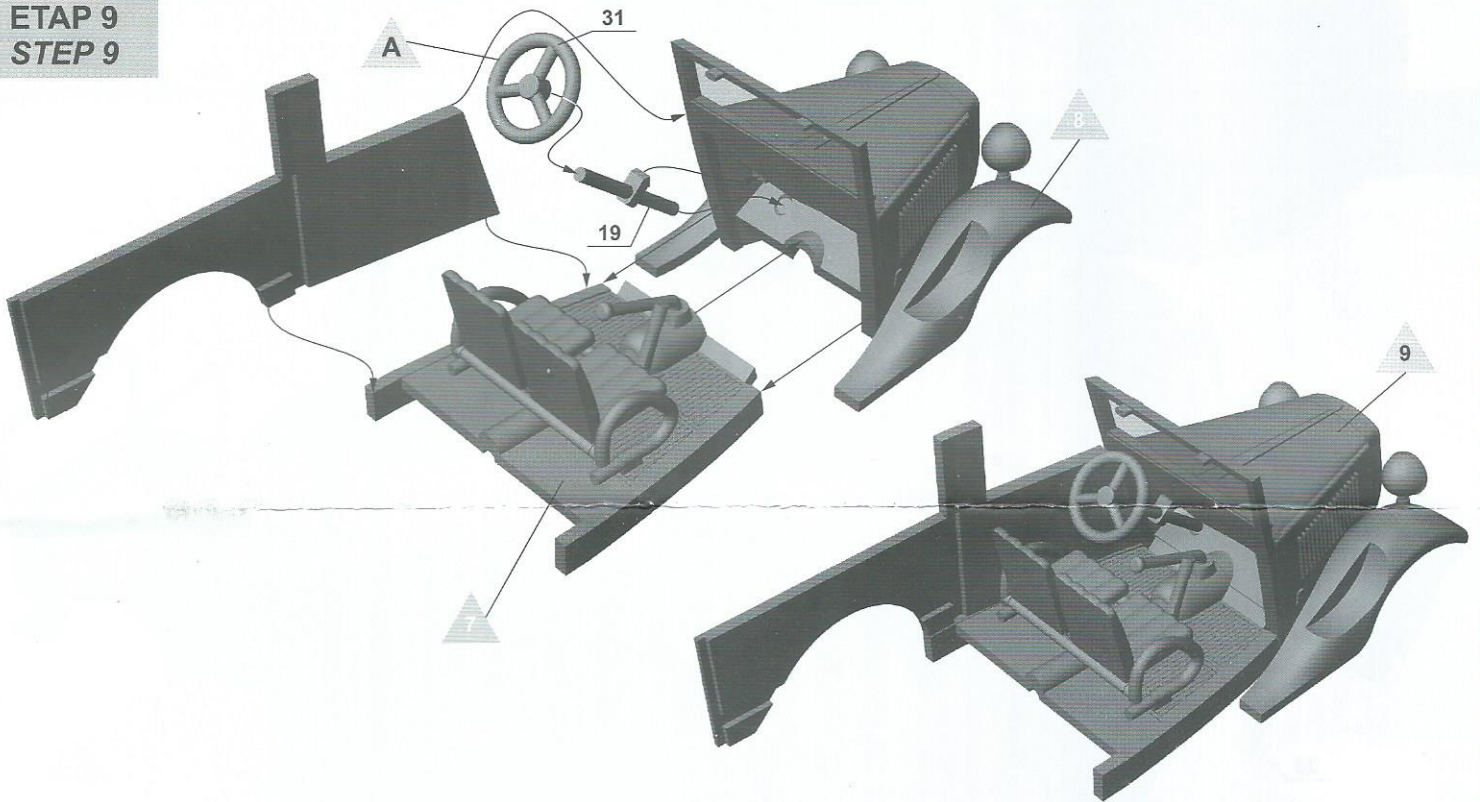

ETAP 10
STEP 10

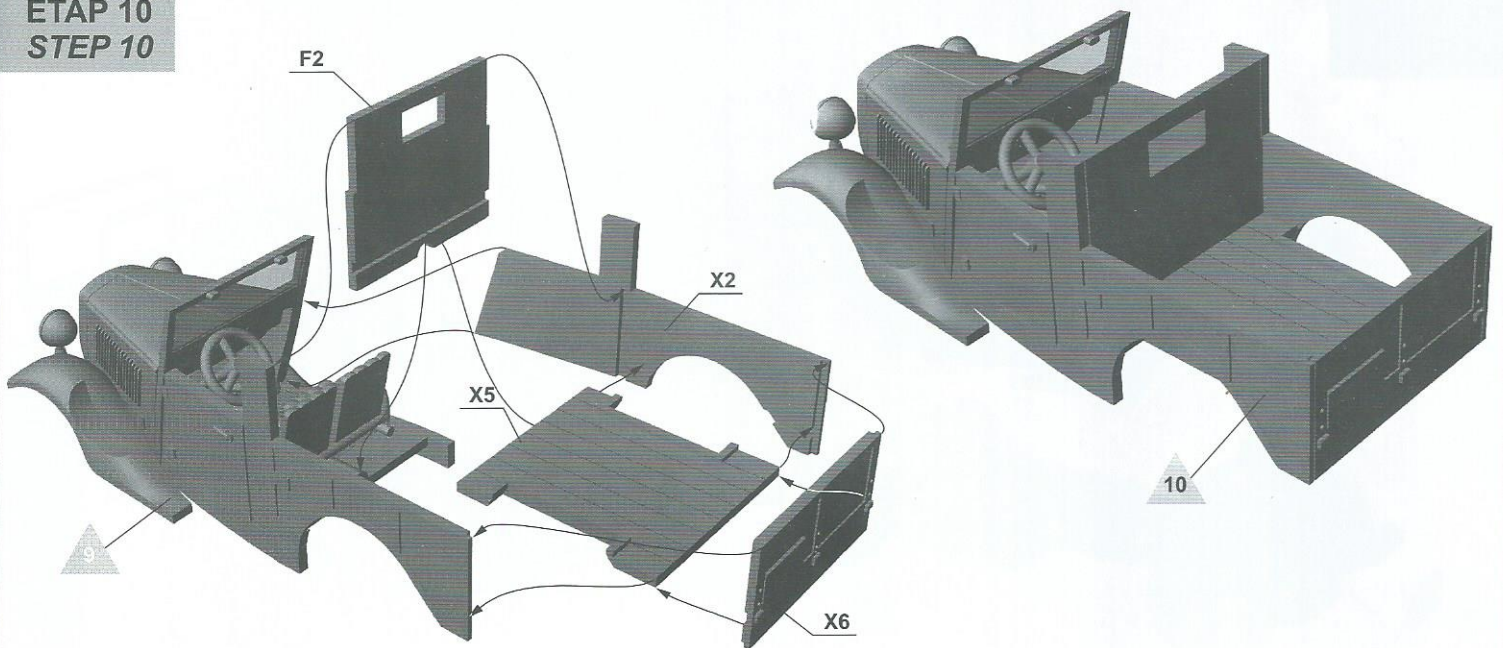

ETAP 11
STEP 11

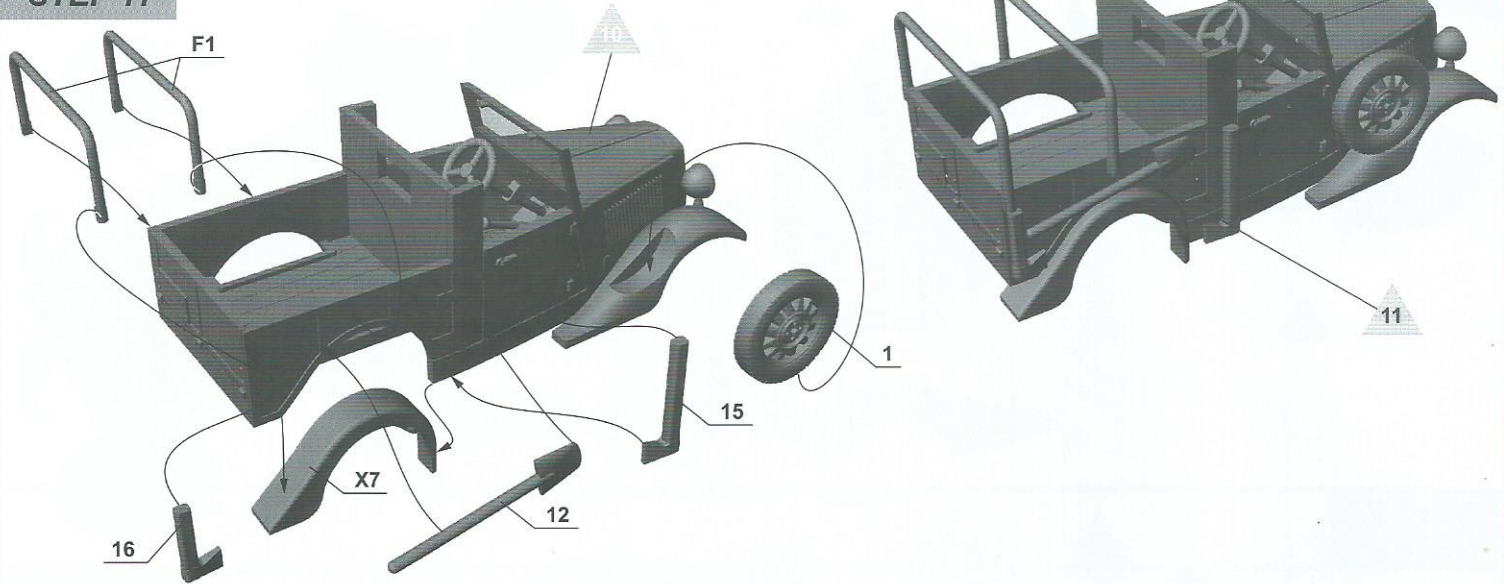

ETAP 12
STEP 12

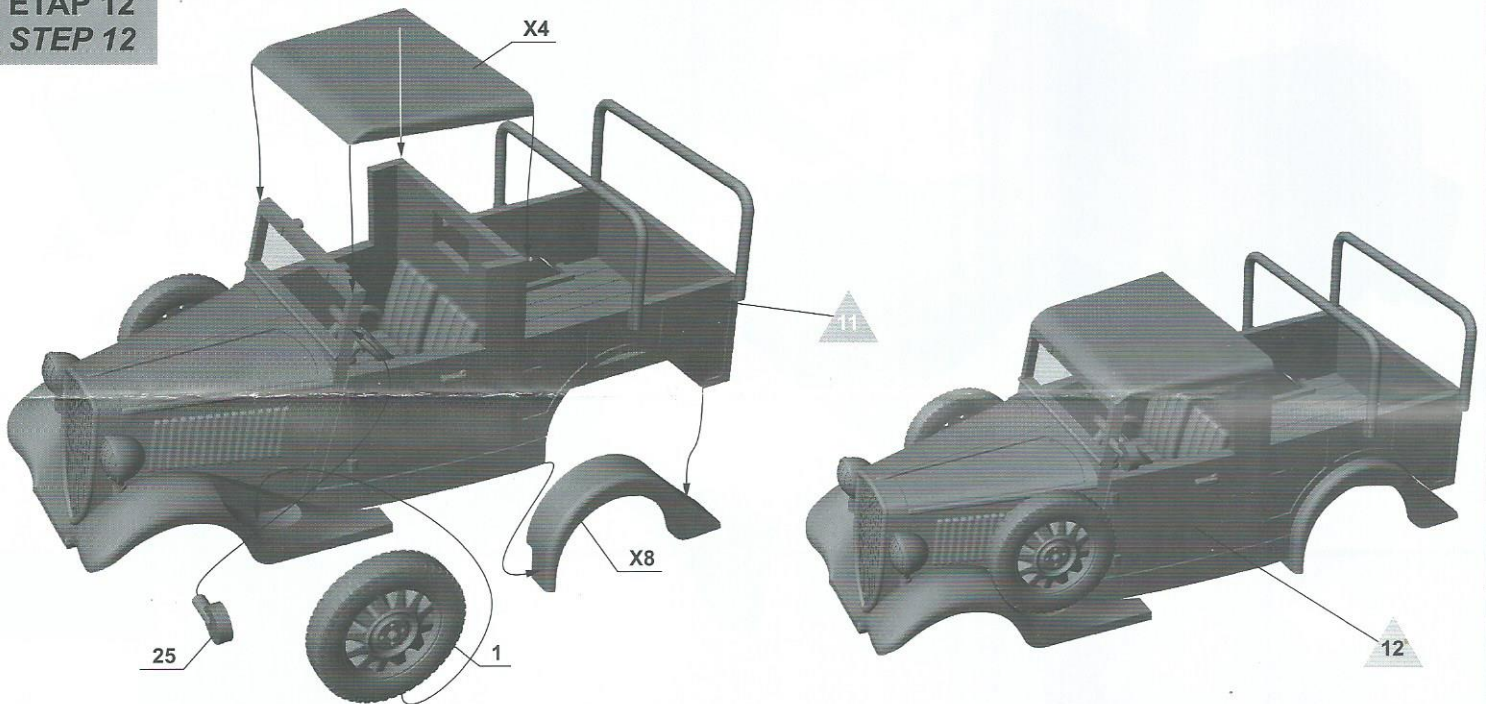

ETAP 13
STEP 13

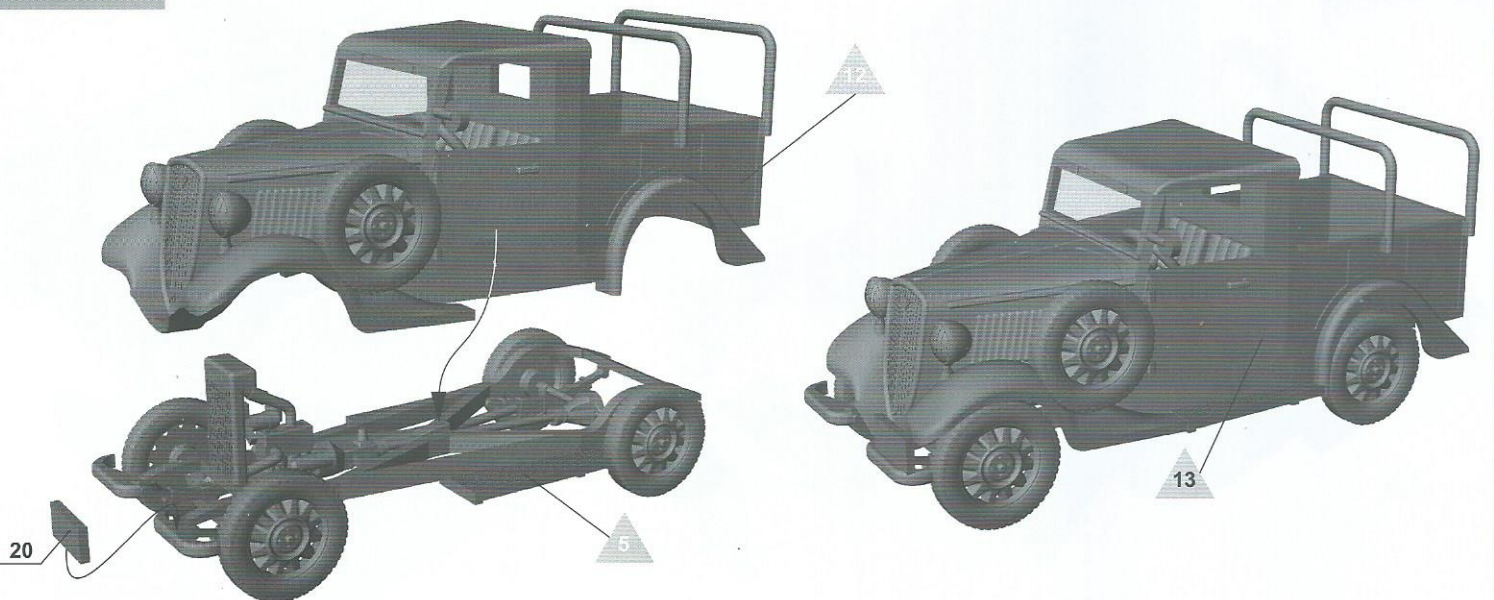

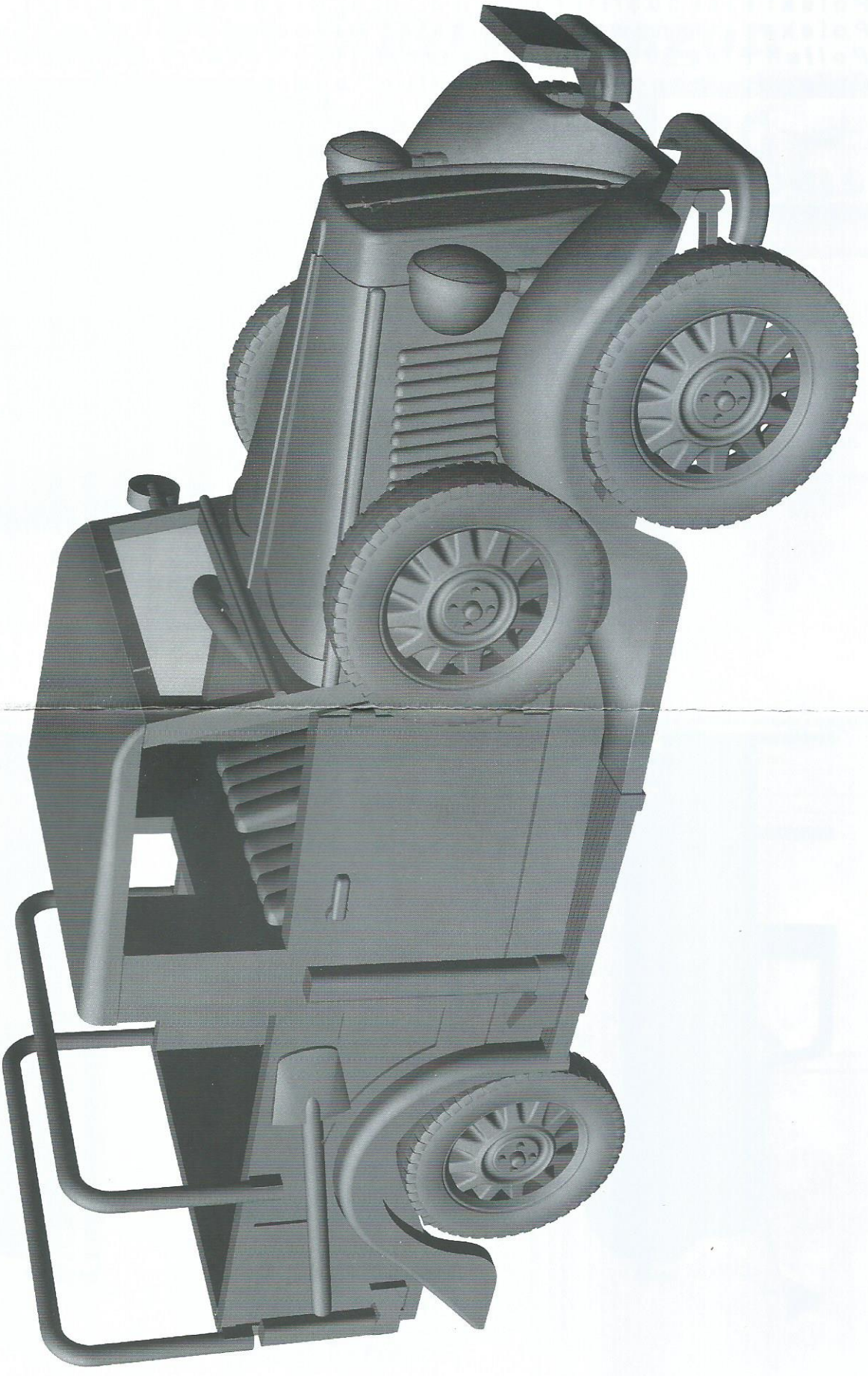

WYKONANY MODEL
FINISHED MODEL

MALOWANIE I KALKOMANIE
COLOURS AND DECALS

**Polski Fiat 508/III furgon z 10tej Brygady Kawalerii
Polska, „maneuwry wołyńskie” wrzesień 1938**
**Polish Fiat 508/III wagon from 10th Cavalry Brigade
Poland, „maneuvers on Wolyn” september 1938**

