

**1****2**

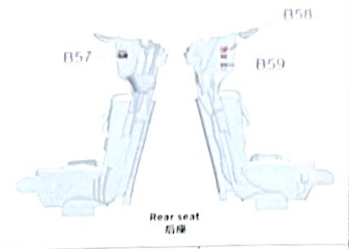

总代理 海模

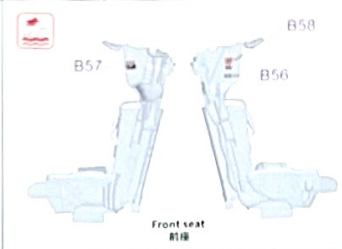
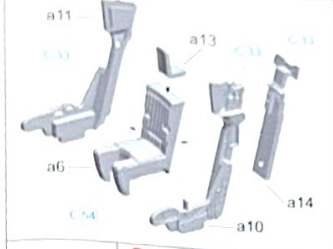
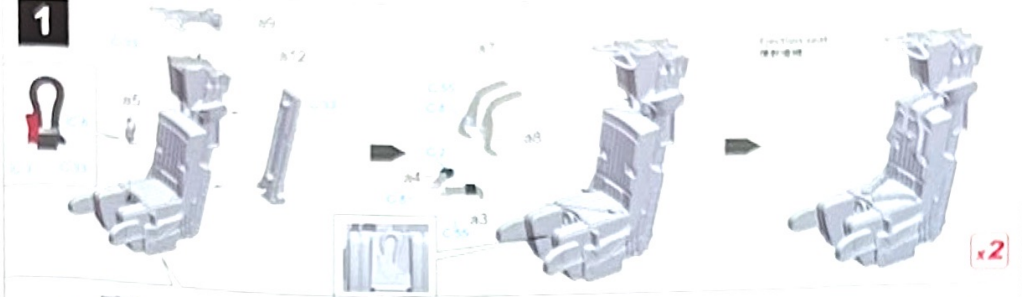
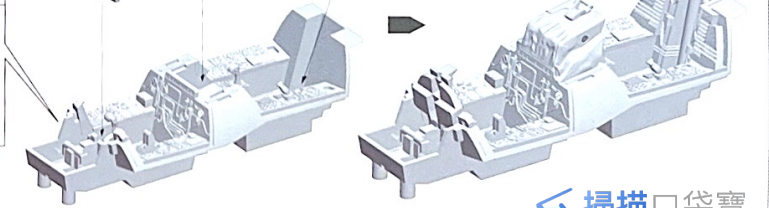
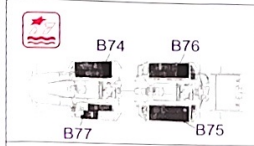
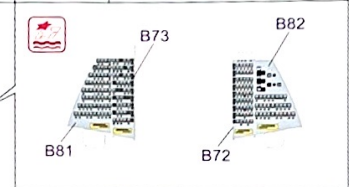
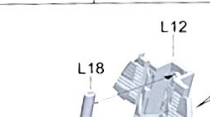
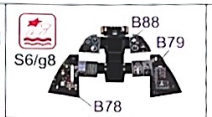
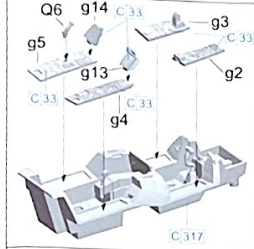
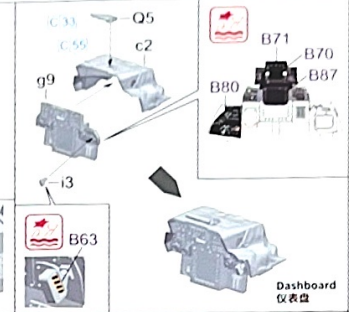
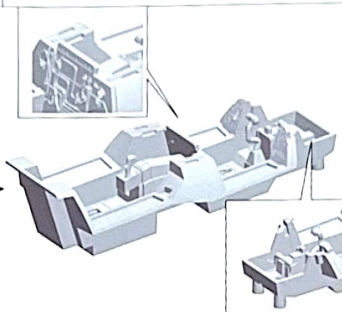
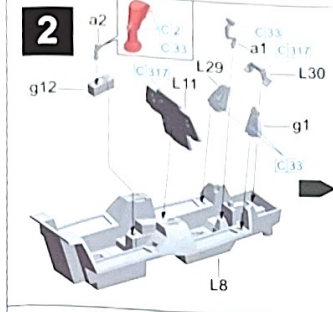
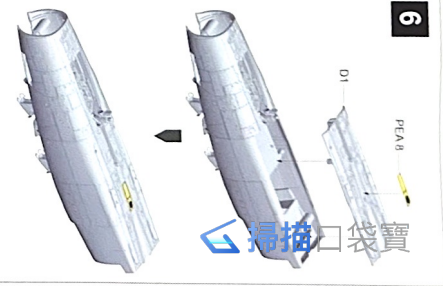
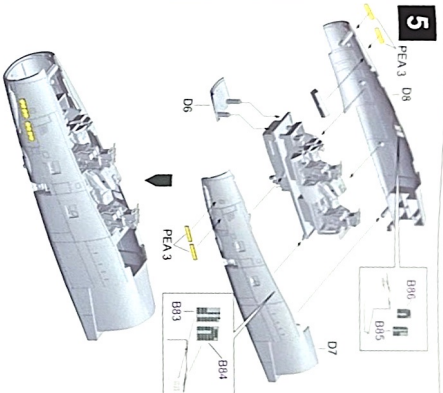
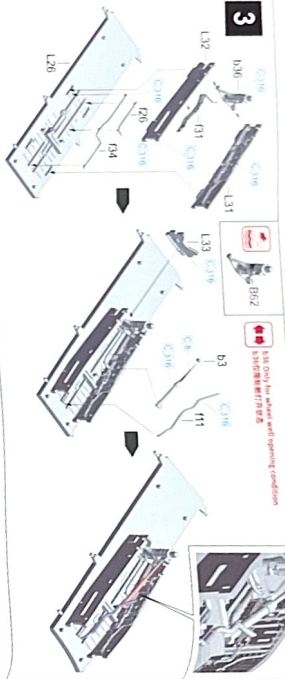
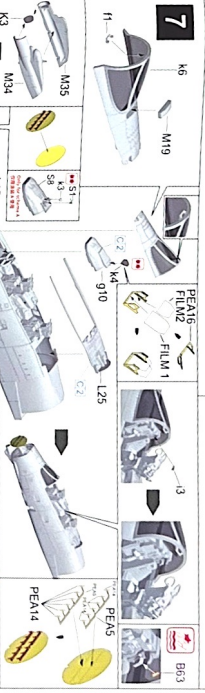
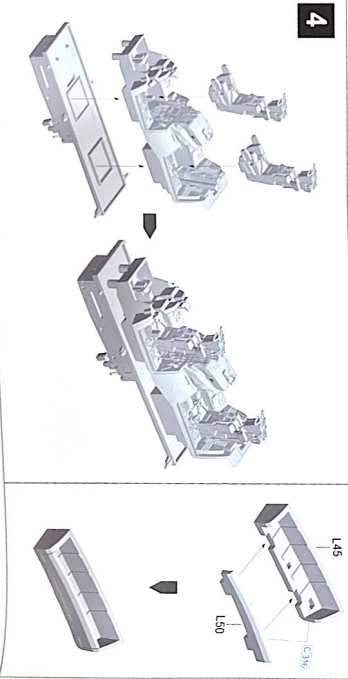
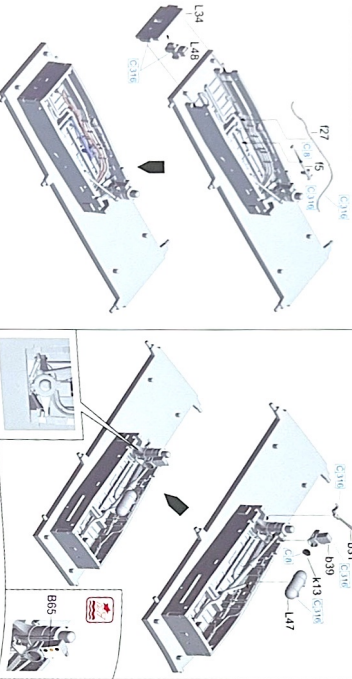

9

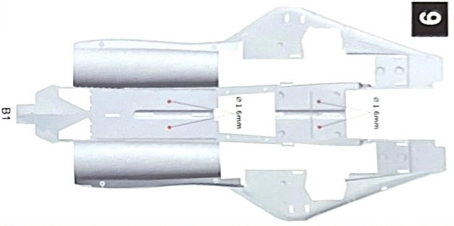

**注意** (Caution)  
 请小心操作，防止划伤零件。  
 Please be careful to avoid scratching the parts.

10

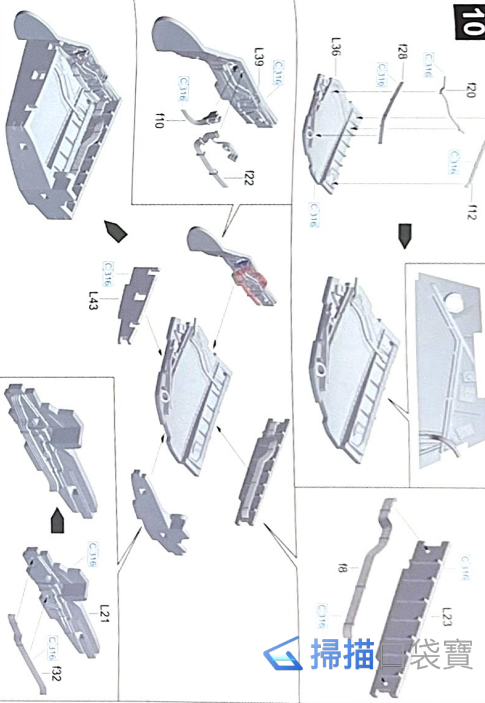

10

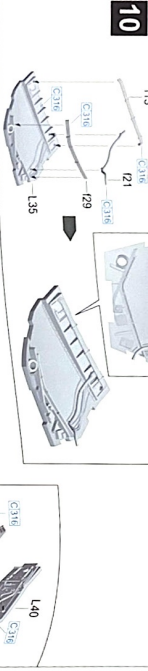

4

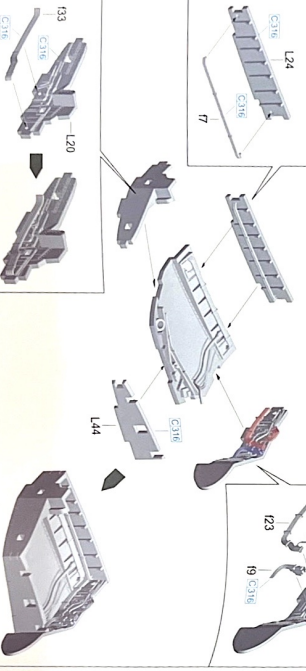

11

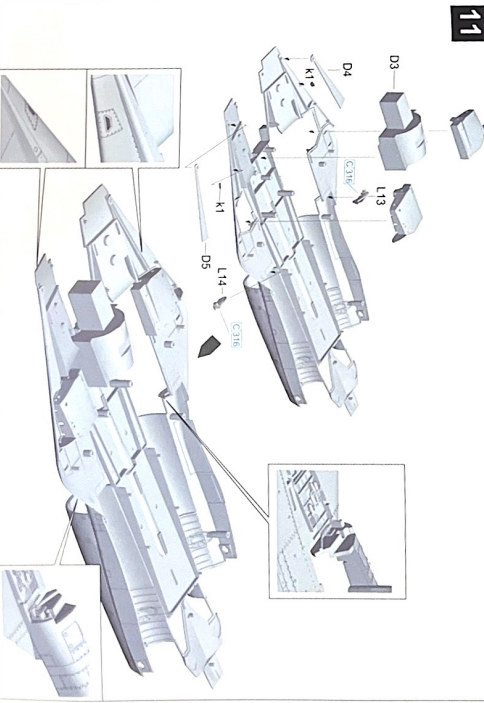

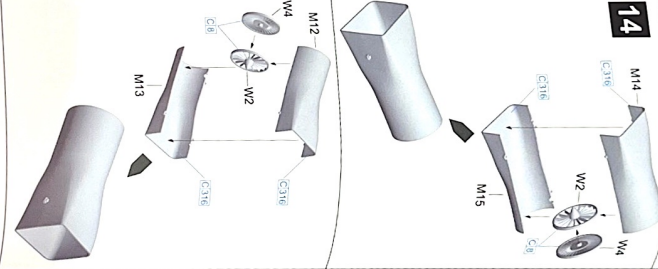
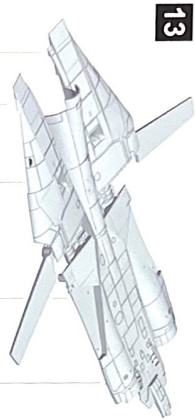
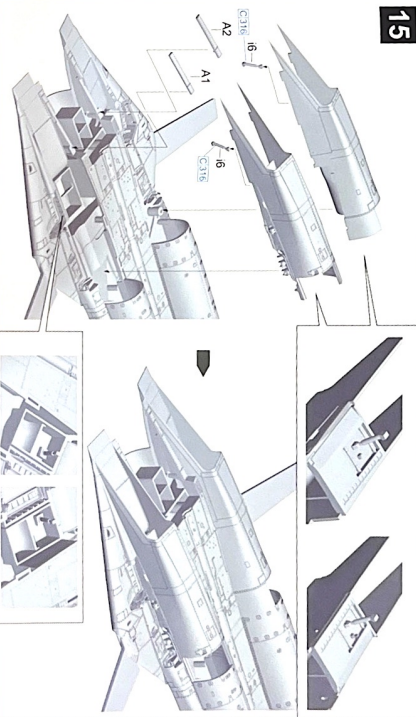
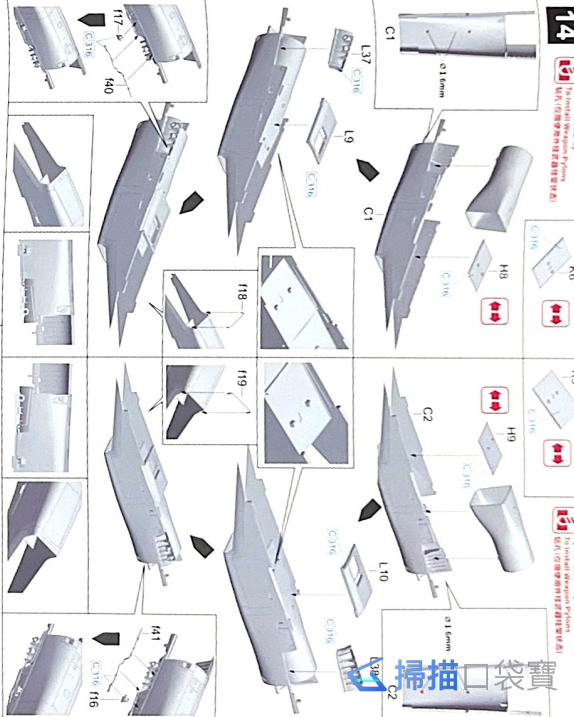
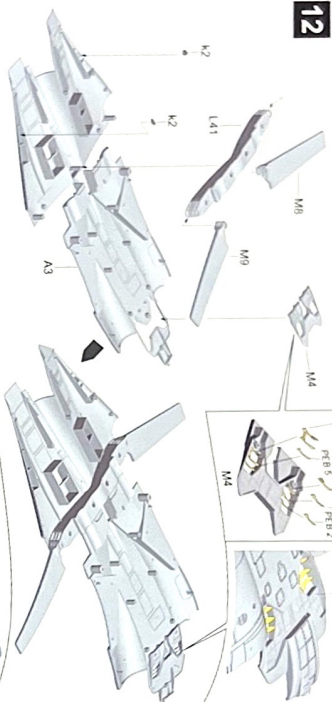

16

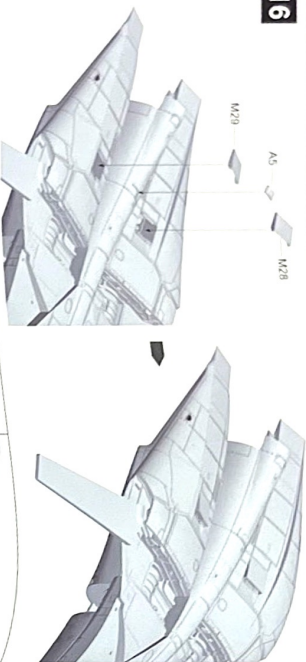

17

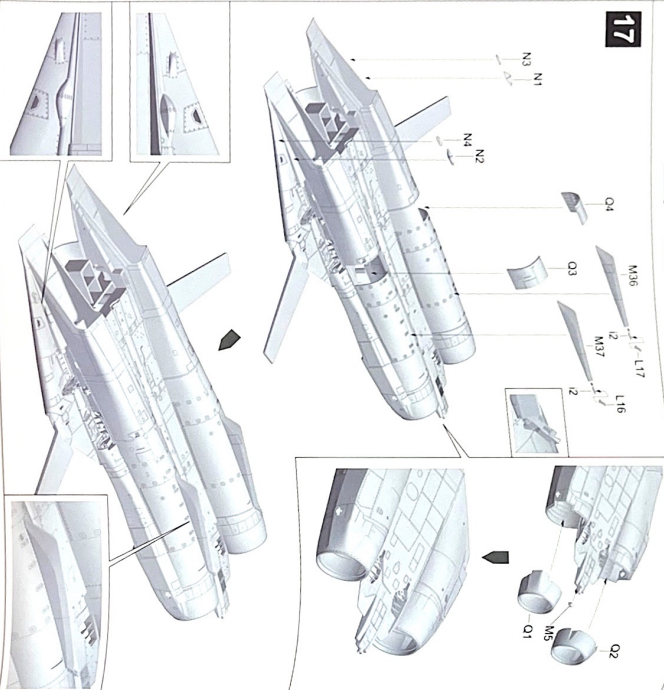

18

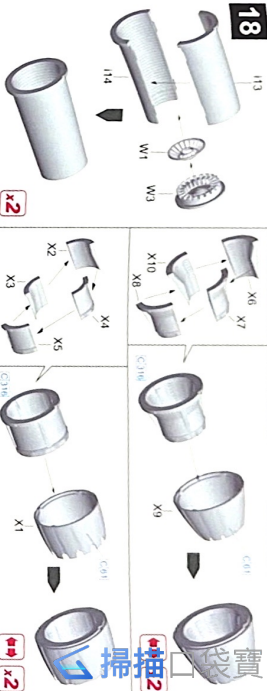

18

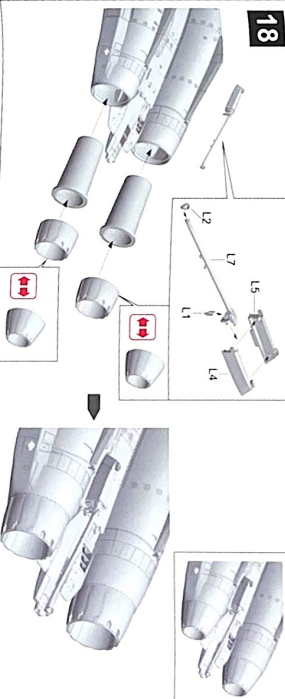

19

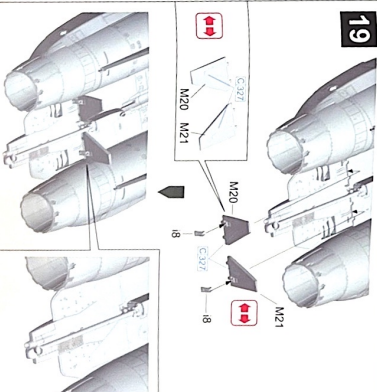

20

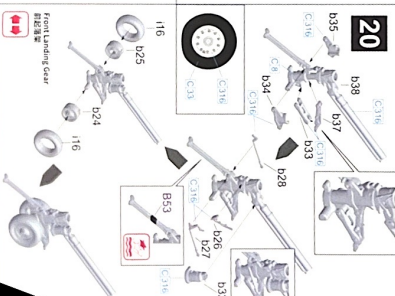

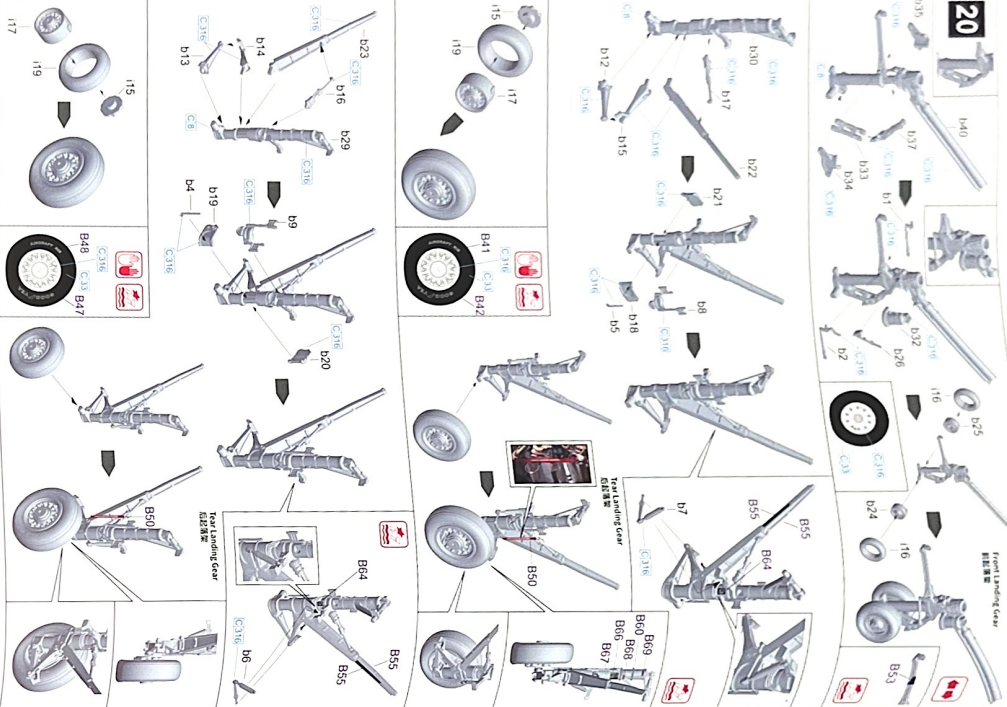

Front Landing Gear 前起落架

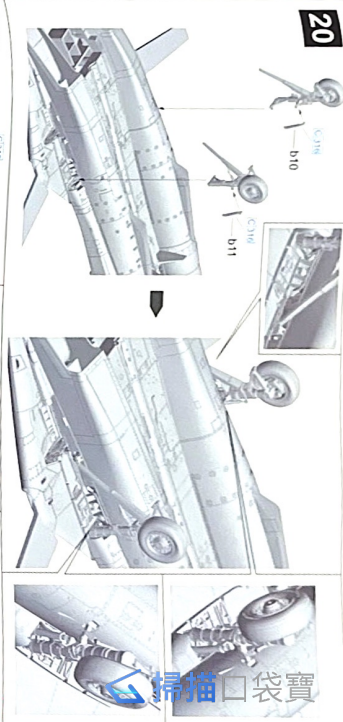

前起落架

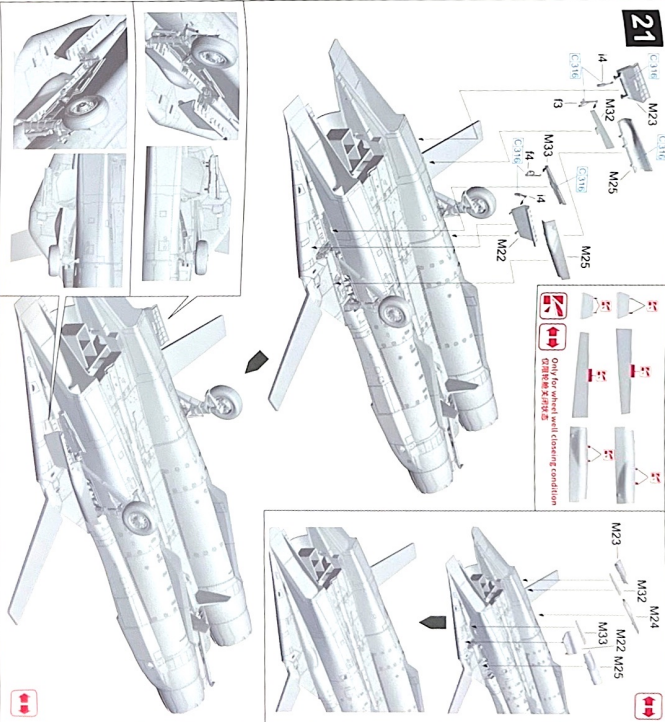

主起落架

主起落架

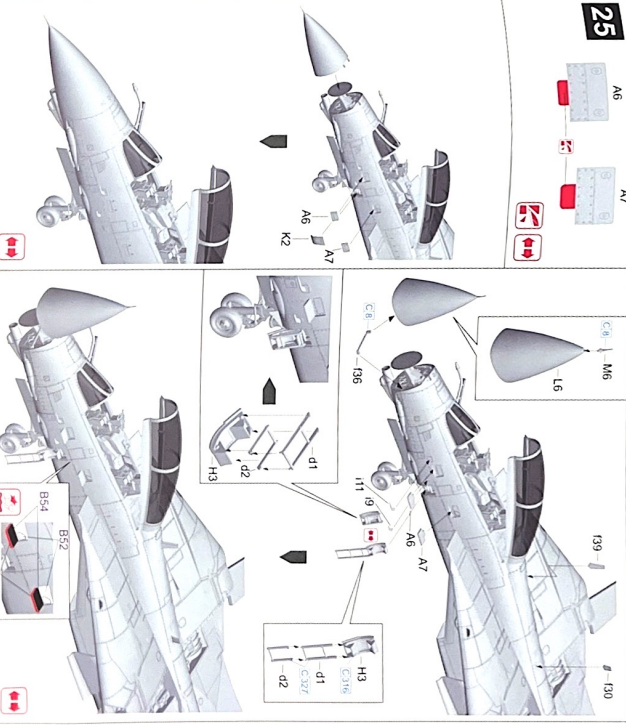
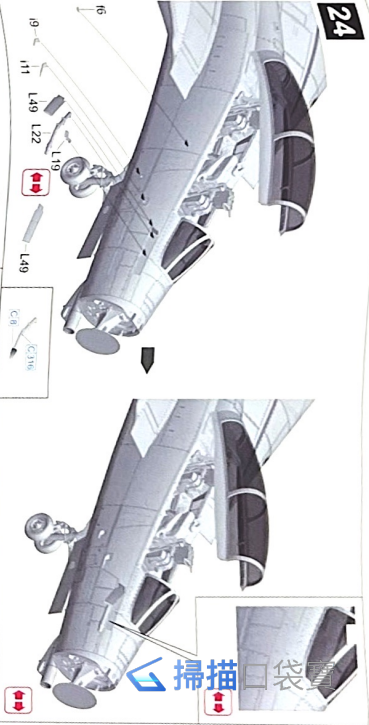
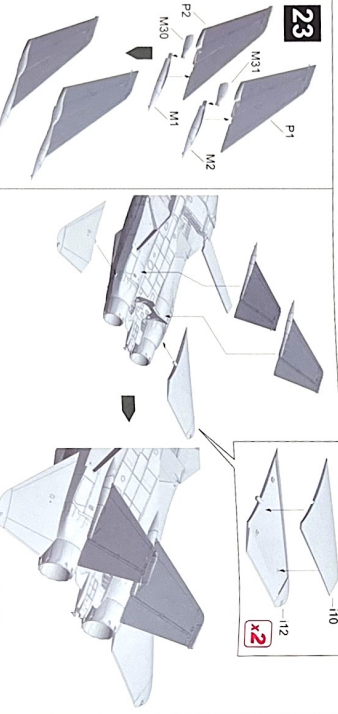
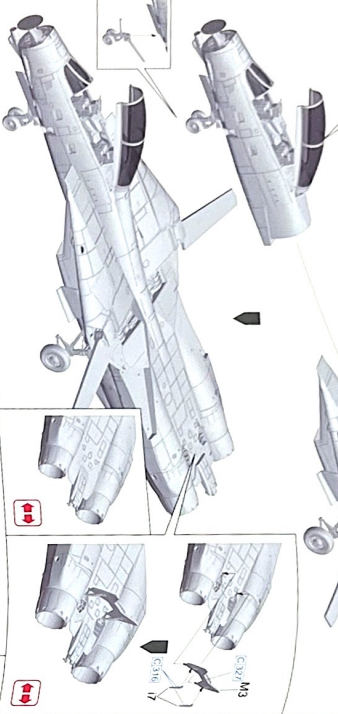
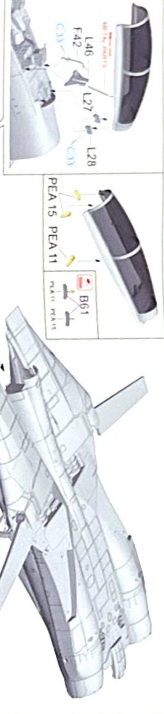

26

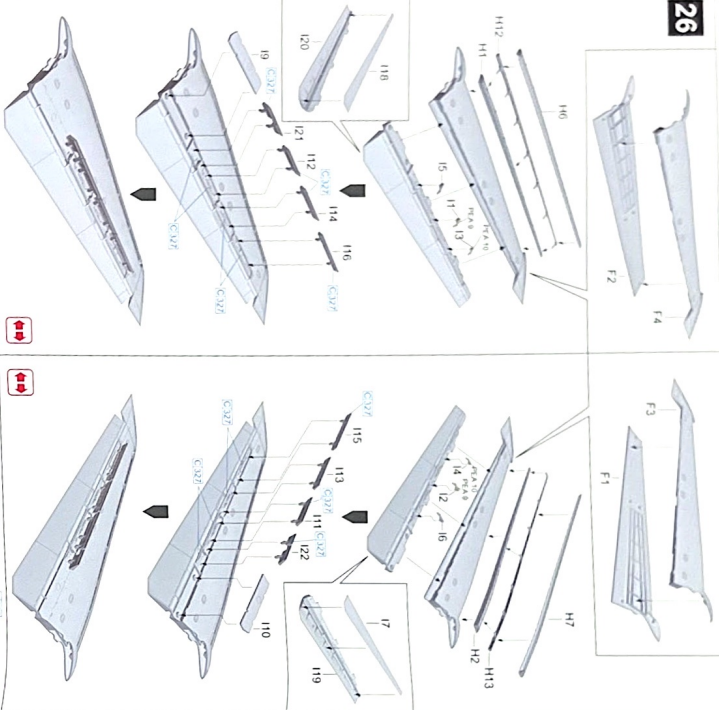

14

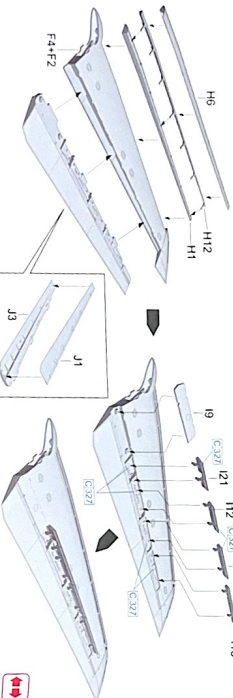

LEAP5 4.00 TORQUE

26

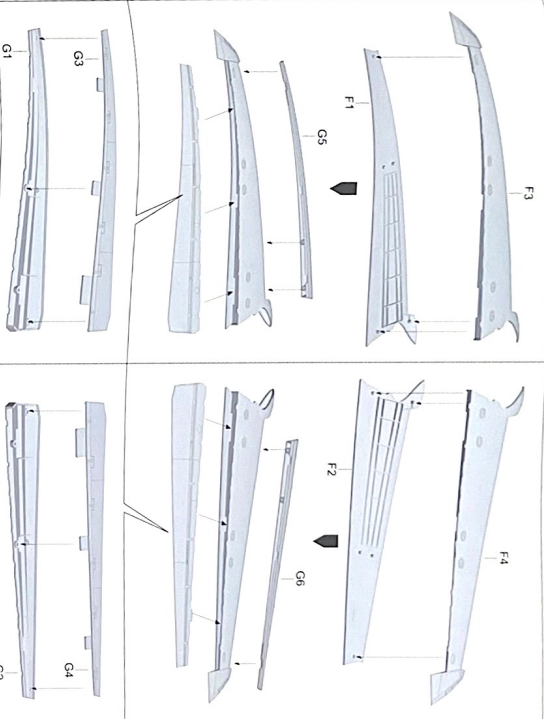
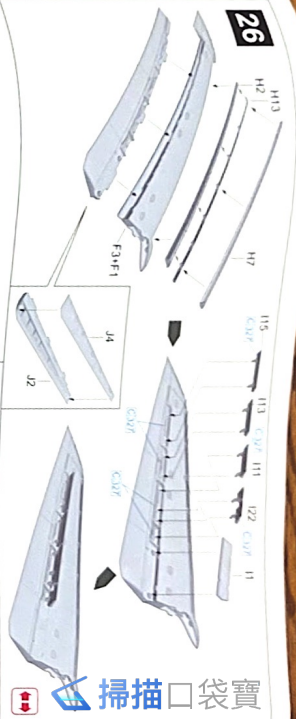

15

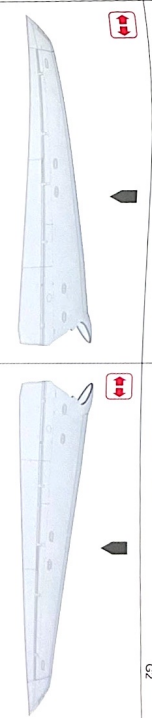

LEAP5 4.00 TORQUE



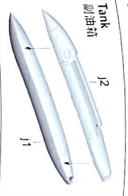
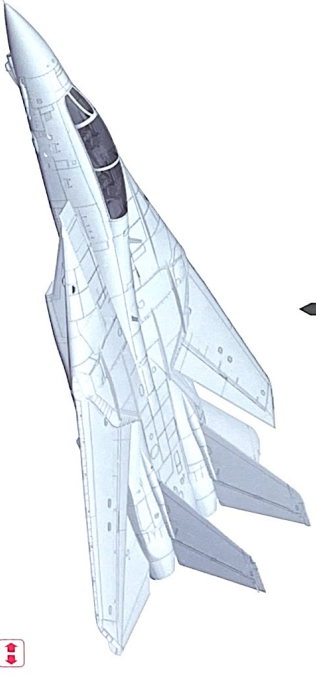
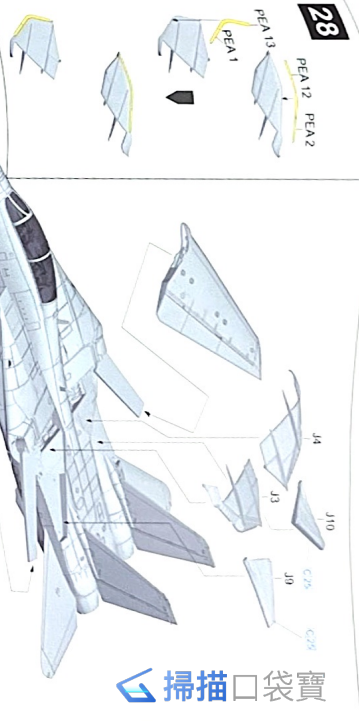
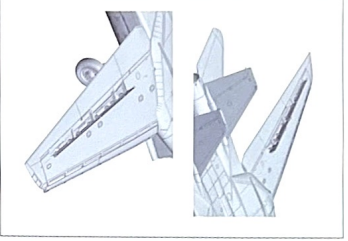
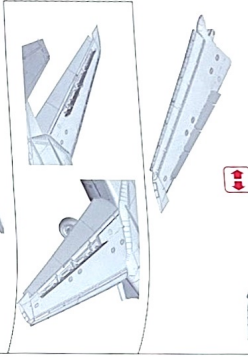
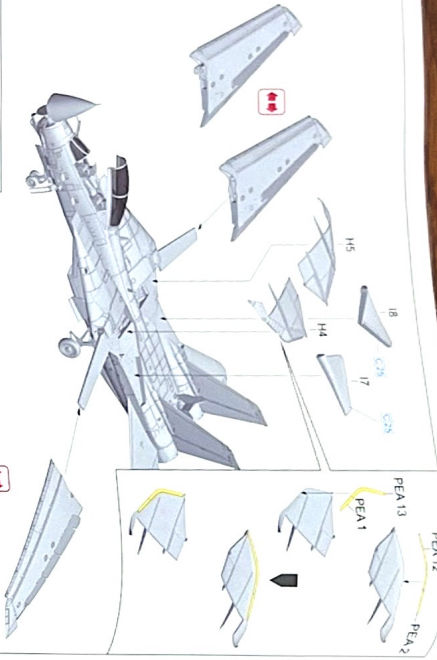

Tank 油箱

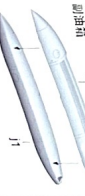

AIM-7F Missile  
AIM-7F 导弹

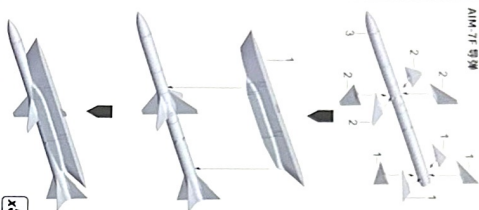

AIM-9L Missile  
AIM-9L 导弹

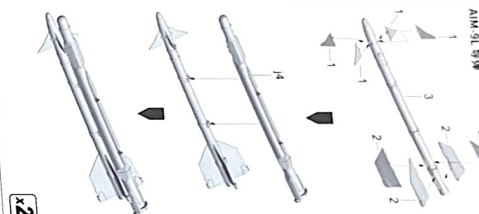

AIM-54C Missile  
AIM-54C 导弹



Pylon  
挂架

x5

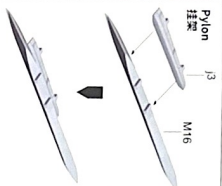

M17

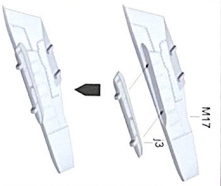

Pylon  
挂架

x2

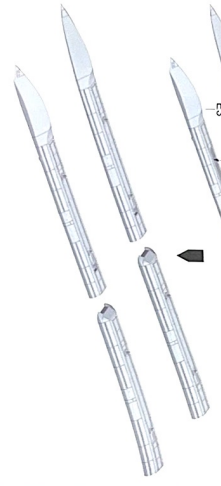
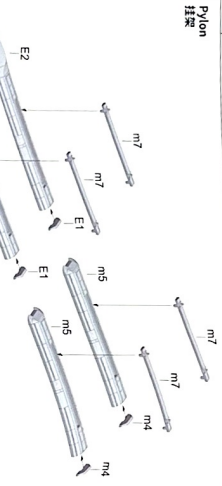

30

WARNING! 危险!

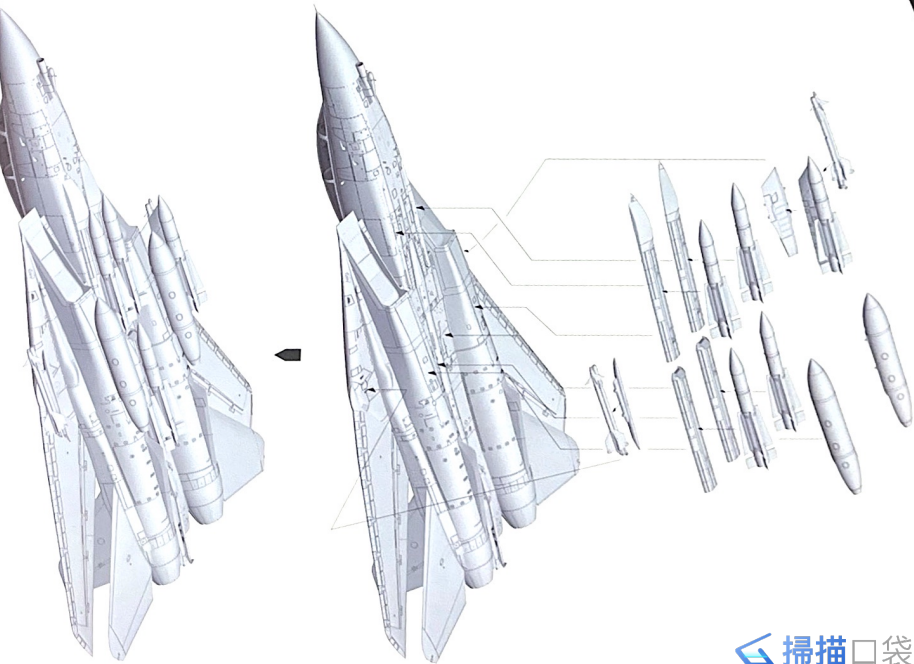

扫描口袋宝

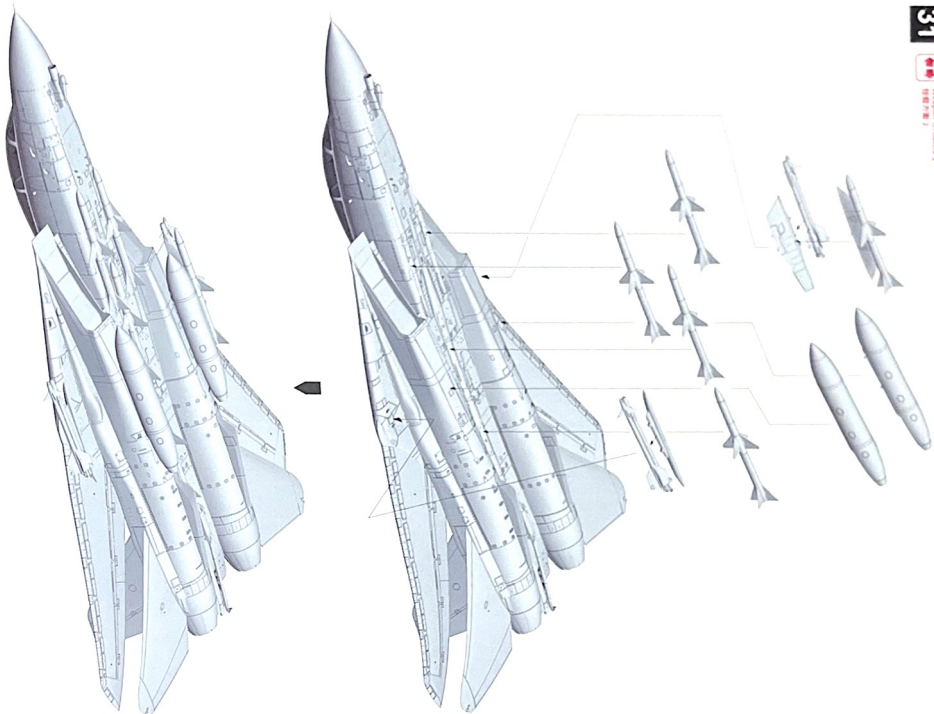
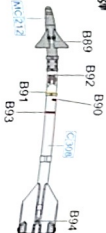
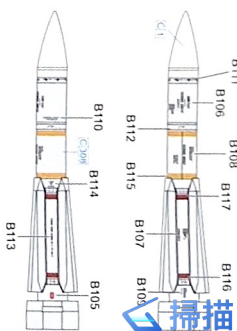
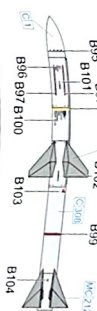
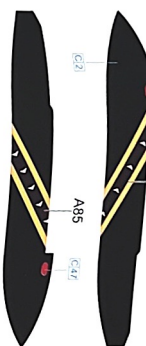
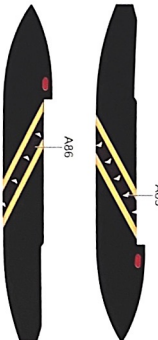
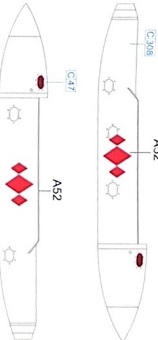
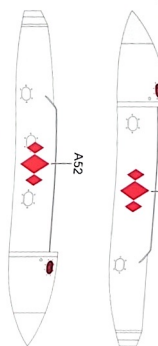
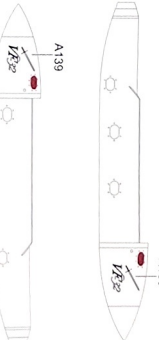
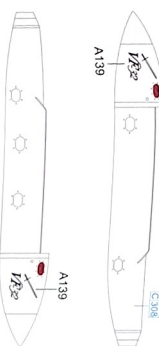
**AIM-9L Missile**  
**AIM-9L 導彈**

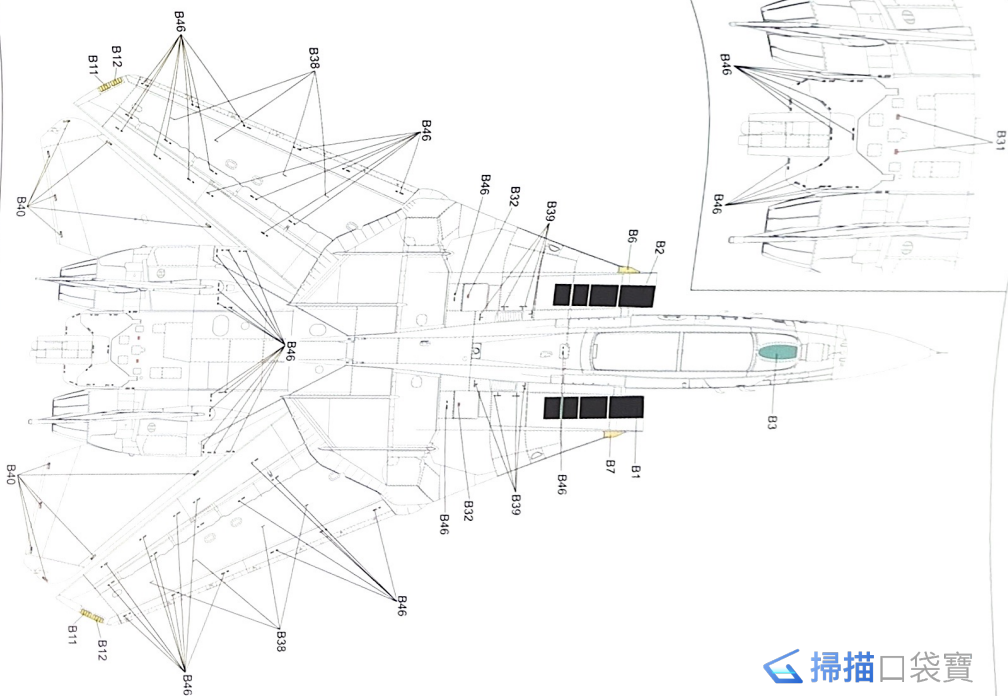
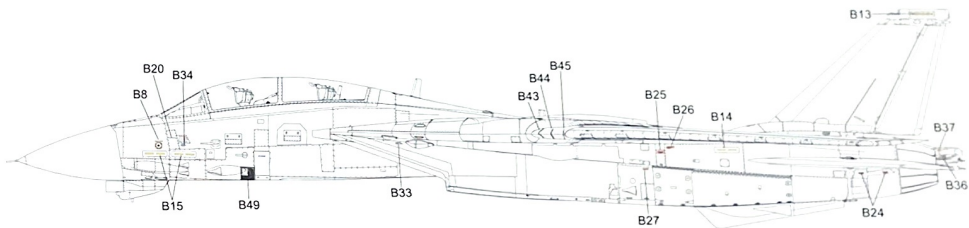
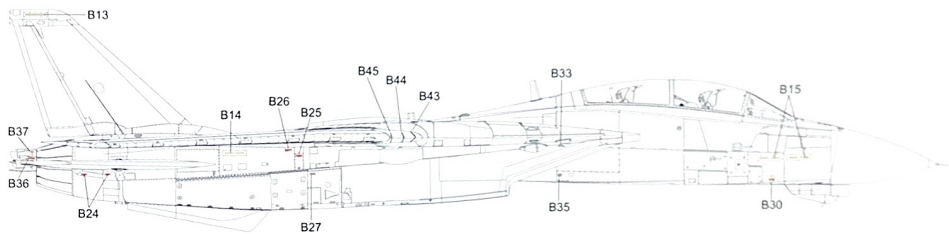
**AIM-54C Missile**  
**AIM-54C 導彈**

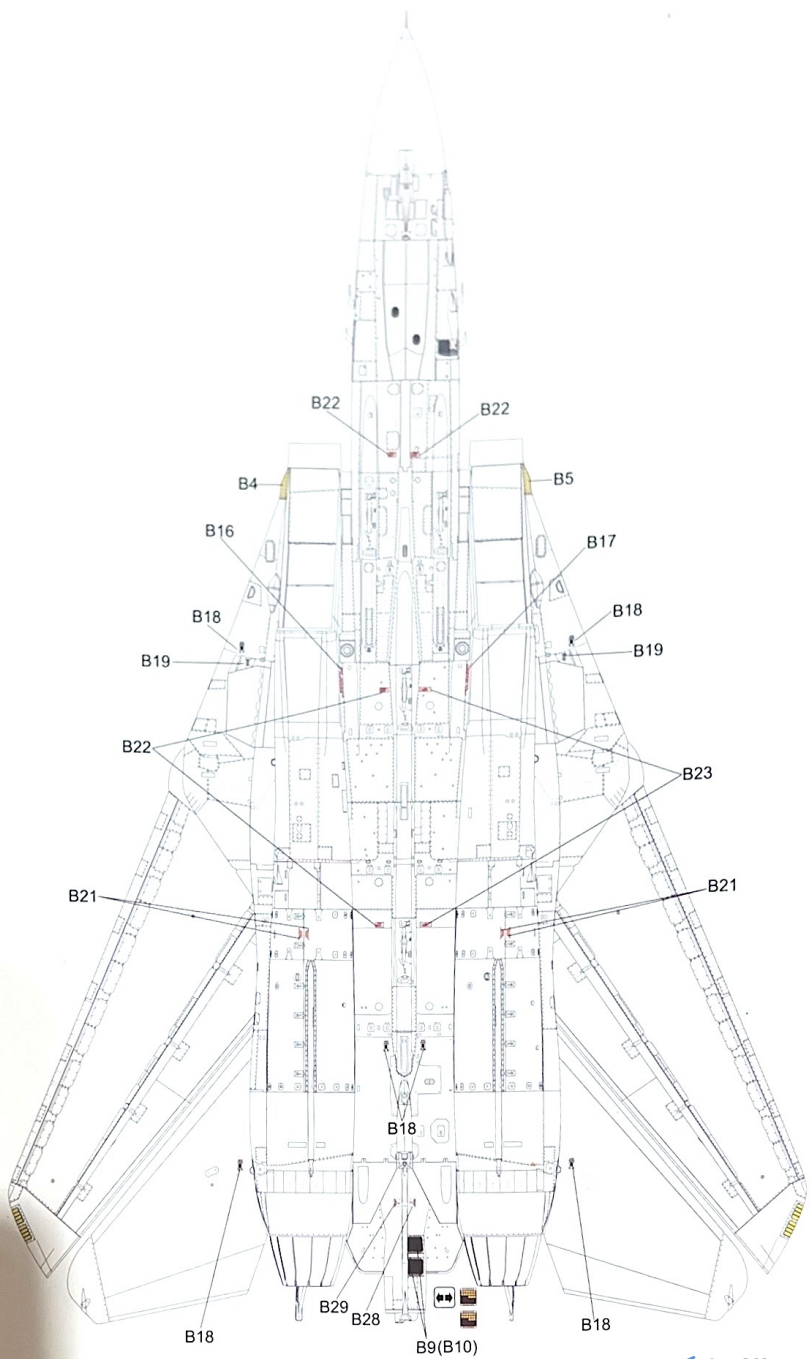
**AIM-7E Missile**  
**AIM-7E 導彈**

**Scheme A**  
**方案 A**  
**Left Tank**  
**左側油箱**

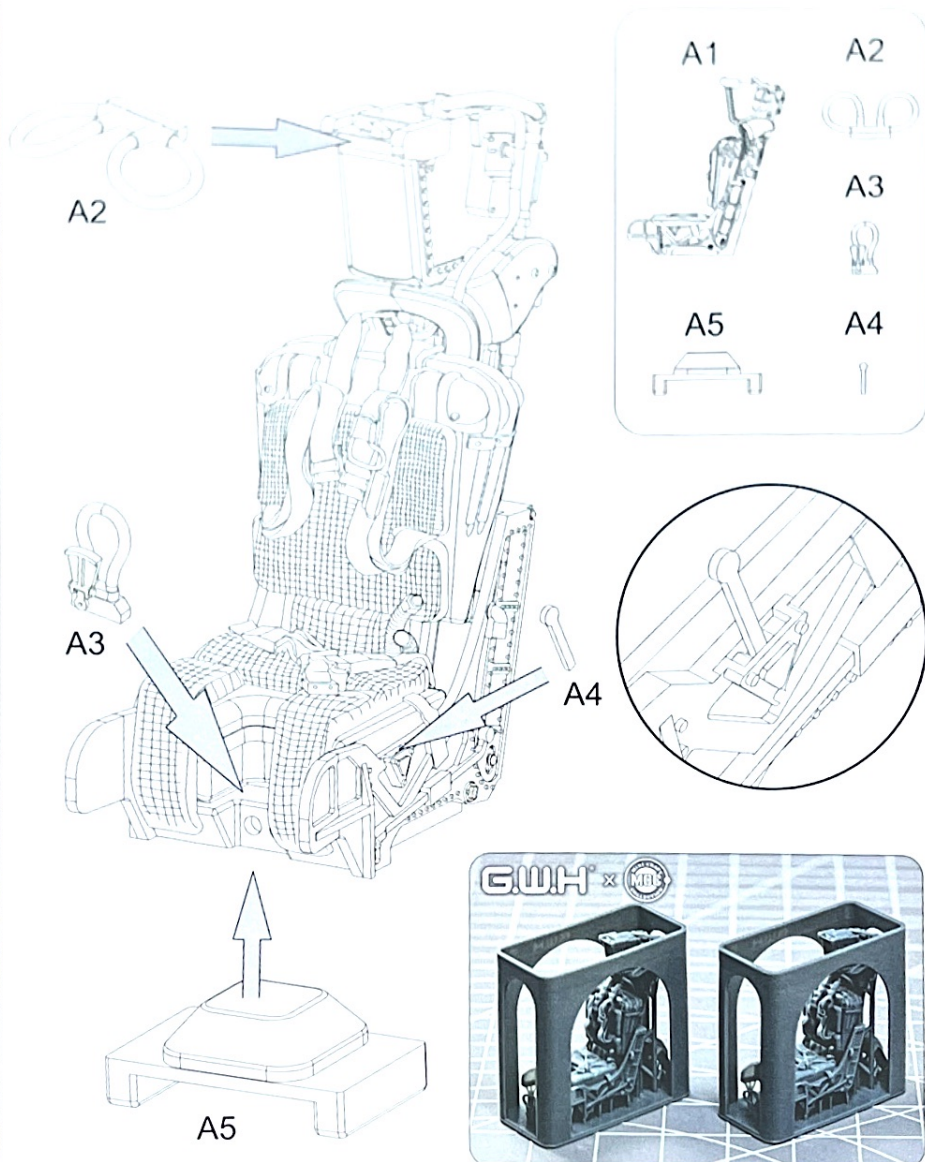
**Right Tank**  
**右側油箱**

**Scheme B**  
**方案 B**

**Scheme C**  
**方案 C**





Designed for G.W.HF-14B



# GWH F-14B TOMCAT "雄猫" 战斗机

1/48 AIRCRAFT PARTS LIST

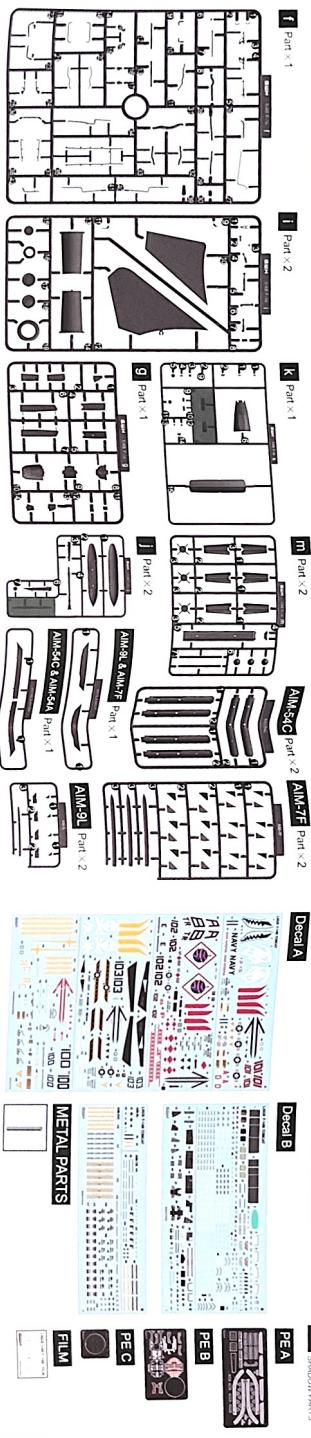
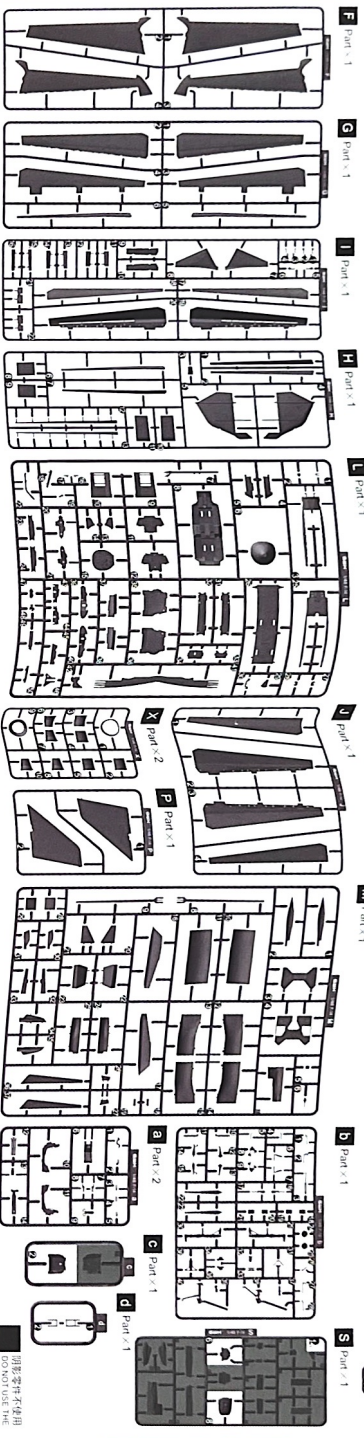
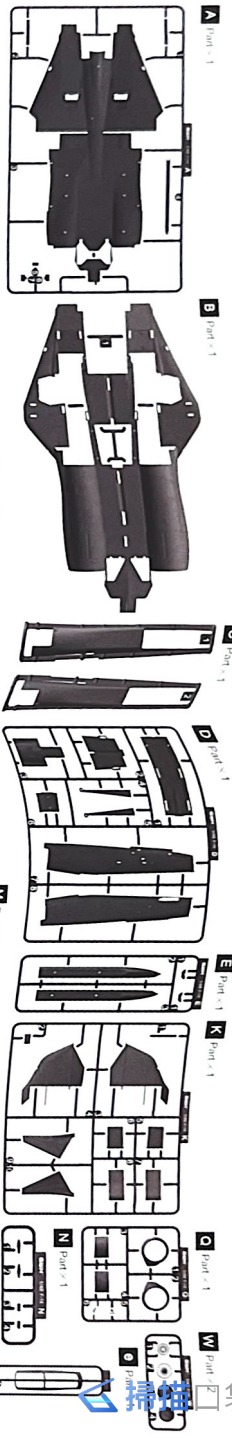

**Decal A**

**Decal B**

**METAL PARTS**

**FILM**

**PEC**

**PEB**

**PEA**

注意零件不使用时  
请勿剪去以免  
影响其他零件  
的黏贴

# F-14B TOMCAT “雄猫”战斗机

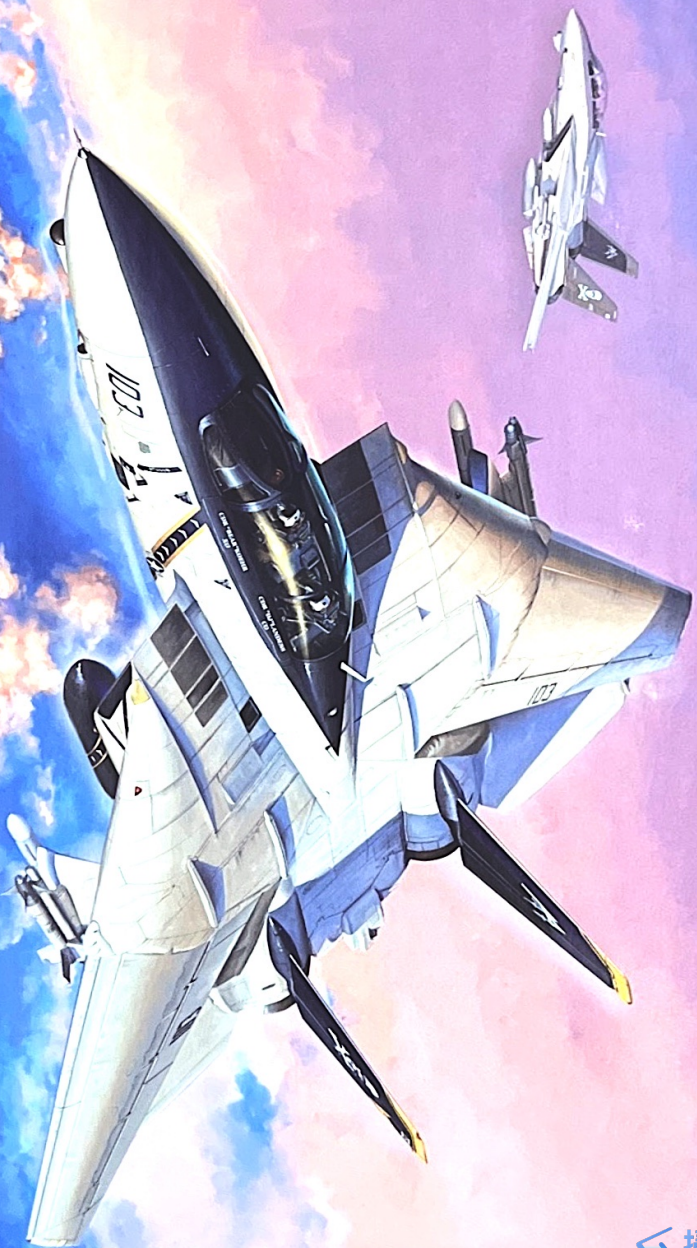

G.W.H.®

1/48  
L4828



## 注意事項 CAUTION 読み立ての注意

本製品の使用にあたっては、以下の警告内容を守り、安全かつ正確な製作を行うよう注意してください。また、本製品の取り扱いにあたっては、以下の注意事項を守ってください。

- 1) Other than glue or paint do not use make a cement frame and use in a well-ventilated room.
- 2) See below for the color list (Glue and paint are not included in this list).
- 3) When you take parts off the runner frame use the modeling scissors and trim excess plastic with a cutter or a file.
- 4) See below for the meaning of symbols.

- 1) 接着剤や塗料は火の通じにくい場所で使用してください。使用の際は換気をよくして下さい。
- 2) 色料用紙は必ず下記の色紙を選んで下さい。接着剤や塗料は本製品のランナーから切り離す時は模型用ハサミや専用剪で、余白部分にはカッターやメスで仕上げてください。
- 3) 組立時のサインマークは下の説明を御覧ください。

## 図面含义 CAUTION マーク

 透写 FOLI HOLE 透写して下さい	 水溶性接着剤 APPLY OF GLUE グルーを塗ってください	 切断 CUT OFF 切り取ってください	 湾曲 BEND 湾曲して下さい	 2x 制作範囲 MAKE 2X SET 2倍して下さい	 模型用製作 FOR MODEL USE ONLY 発射機は取り外して下さい
 絵具 PAINT 塗ってください	 開孔 OPEN HOLE 穴を開けて下さい	 処理オプション OPTIONAL こちらを選んで下さい	 不用接着剤 NO CEMENT 接着剤はしないで下さい	 ! 注意 BE CAREFUL 注意して下さい	 瞬間接着剤 瞬間接着剤 瞬間接着剤(多量使用)

## 所使用工具 RECOMMENDED TOOLS 専用工具



模型用接着剤水  
Cement  
プラスチック用接着剤



模型用前田  
Sale cutters  
模型用ハサミ



模型用ピンセット  
Tweezers  
ピンセット

模型用研刀  
Diamond file  
模型用ヤスリ

## 水貼紙使用説明 DECAL APPLICATION スライドマークの貼り方

- 1) 用模型研刀(または)切子所需の箇所を削る。
- 2) 特殊紙貼機や温水の中10秒左右取出し置き干す水の汽泡を上げ
- 3) 半量着水貼紙基の一角、用模型ピン子中心付近に水を貼用塗料を模型表面に塗る
- 4) 用半指造り清水均等に水貼用塗料を塗る、使其は縦横移動に正確位置
- 5) 用塗料乾燥の水を清水貼用塗料中の汽泡均一に抽出、使水貼に模型表面を保持平整

- 1) Cut off decal from sheet
- 2) Dip the decal in tepid water for about 10 sec and place on a clean cloth
- 3) Hold the backing sheet edge and slide decal onto the model
- 4) Move decal into position by wetting the decal with finger
- 5) Press decal down gently with a soft cloth until excess water and air bubbles are gone

- 1) 貼りたいマークをハサミで切り抜きます。
- 2) マークをめくる手では、10秒ほど浸してからタオル等の布の上に置きます。
- 3) 台紙のはしを手で持ち、貼るところにマークをスライドさせてモデルに押しつけて下さい。
- 4) 指に少し水を付けてマークを濡らしてながら、正しい位置にずらしします。
- 5) 柔らかい布でマークの内側の気泡を押し出しながらいれ、押しつけるようにして水分をとります。

## 蚀刻片使用説明 PHOTO-ETCHED PARTS エッチングパーツ

- 1) 使用蚀刻片専用研刀或模型専用研刀將蚀刻片零件切断下待用。
  - 2) 切断下の零件上有蚀刻片の残留连接点部分、使用模型専用研刀細心打磨干净。
  - 3) 蚀刻片部分在塗装之前先塗用专用的模型金属底漆打底。
- 注意事項: 蚀刻片很薄外盒较为尖锐, 有划伤手的可能, 在使用之时请务必小心。

- 1) Cut off photo-etched parts using a modeling knife
- 2) Carefully remove any excess using a file
- 3) Apply metal primer prior to painting  
Attention please Extra care should be taken to avoid personal injury when handling photo-etched parts

- 1) 切り離す時はカッターナイフを使用してパーツを切り離します。
- 2) 切り出した時、部品に出っ張った部品が残っている場合は、ヤスリなどで丁寧に削り落とします。
- 3) 塗装が必要なパーツは下地にメタルプライマーを吹き付けてから塗装します。  
ご注意ください エッチングパーツは大変薄く、手などを切り恐れがあります。取扱には十分注意して下さい。

## 塗装色表 PAINT REQUIRED カラー番号リスト

■ [C]000 GSI CREOS Mr COLOR ■ [00-000] ACRYLICOS VALLEJO

[C]1	亮光白	White
[C]2	亮光黑	Black
[C]3	亮光红	Red
[C]8	亮光银	Silver
[C]25	暗海蓝	Dark sea blue
[C]33	消光黑	Extinction black
[C]47	透明红	Clear red
[C]54	卡其绿	Khaki green

[C]55	卡其色	Khaki
[C]61	烧铁色	Burnt iron
[C]138	透明绿	Clear green
[C]307	蓝灰FS36320	Blue grey FS36320
[C]308	灰FS36375	Grey FS36375
[C]316	光泽白FS17875	White FS17875
[C]317	消光灰FS36231	Grey FS36231
[C]327	亮光红FS11136	Light red FS11136

[C]328	亮光蓝	Light grey
[C]337	灰蓝色	Grey blue
MC]212	深灰色	Grey