

# Revell

KIT 5518

85551800200

## F-102A DELTA DAGGER

In the years following World War II, the Soviet Union developed atomic bombs and built a large bomber force capable of delivering them over intercontinental ranges against any target in the United States. To defend the airspace over North America, the United States Air Force issued a request for proposals to the aircraft industry in June 1950 calling for the development of a supersonic jet interceptor armed with rockets and guided missiles. Convair's design for the F-102A was developed from that company's XF-92, and on September 11, 1951, the Air Force issued a contract for the development of the new interceptor.

The YF-102 prototype first flew on October 24, 1953, and after considerable design refinements, the first production F-102A made its initial flight on June 24, 1955. F-102As began to enter operational squadron service in April 1956. Called the Delta Dagger, the F-102A was the first interceptor in the U.S. Air Force capable of sustaining supersonic speed in level flight.

Armament of the Delta Dagger usually included six AIM-4 Falcon air-to-air guided missiles, three of which were radar guided and three of which were infrared guided. This mix of guidance systems increased the chances that the pilot of the interceptor could defeat counter measures used by enemy bombers. Additionally, twelve 2.75-inch unguided rockets were carried in launch tubes inside the doors of the missile bays. To destroy several bombers at once, the AIM-26 Falcon missile with a small tactical nuclear warhead could also be employed.

The F-102A and the TF-102A two-seat trainer version served for more than two decades with interceptor squadrons in the U.S. Air Force and the Air National Guard. The last Delta Daggers were retired from duty in the mid-1970s. Decals included with your Revell F-102A model provide markings for two different aircraft. One is an F-102A from the 496<sup>th</sup> Fighter Interceptor Squadron at Hahn Air Base, Germany, in 1961, and the second is an F-102A assigned to the 102<sup>nd</sup> Fighter Interceptor Squadron of the New York Air National Guard in January 1973.

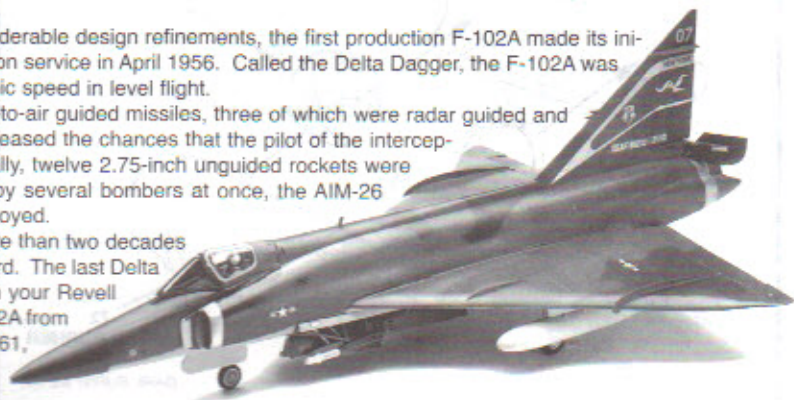

\* REPEAT SEVERAL TIMES  
\* A RÉPÉTER PLUSIEURS FOIS



\* OPTIONAL PARTS  
\* PIÈCES EN OPTION



\* DECAL  
\* DECAL COMMANE



\* ALTERNATIVE ASSEMBLY  
\* ENSEMBLAGE ALTERNATIVE



\* CEMENT TOGETHER  
\* A COLLER



\* REMOVE AND THROW AWAY  
\* A RETIRER ET JETER



\* DO NOT CEMENT  
\* NE PAS COLLER

### READ THIS BEFORE YOU BEGIN

- Study the assembly drawings.
- Each plastic part is identified by a number.
- For better paint and decal adhesion, wash the plastic parts in a mild detergent solution. Rinse and let air dry.
- Check the fit of each piece before cementing in place.
- Use only cement for polystyrene plastic.
- Scrape plating and paint from areas to be cemented.
- Allow paint to dry thoroughly before handling parts.
- Any unused parts may be discarded.

### DECAL APPLICATION INSTRUCTIONS

1. Cut desired decal from sheet.
2. Dip decal in water for a few seconds.
3. Place wet decal on paper towel.
4. Wait until decal is movable on paper backing.
5. Place decal in position on model, face up and slide backing away.
6. Press out air bubbles with a soft damp cloth.
7. Milkyness that may appear is for better decal adhesion and will dry clear. Wipe away any excess adhesive.
8. Do not touch decal until fully dry.
9. Allow the decals 48 hours to dry before applying clear coat.

**NOTE:** Decals are compatible with setting solutions or solvents.

### LIRE CE QUI SUIT AVANT DE COMMENCER

- Etudier les schémas de montage.
- Chaque pièce en plastique est identifiée par un numéro.
- Pour une meilleure prise de la peinture et des autocollants, laver les pièces en plastique avec une solution détergente peu concentrée. Les rincer et les laisser sécher à l'air.
- Vérifier que chaque pièce s'ajuste bien avant de la coller en place.
- N'utiliser que de la colle pour polystyrène.
- Gratter les parties à coller pour enlever le chrome et la peinture.
- Laisser la peinture bien sécher avant de manipuler les pièces.
- Toute pièce inutilisée peut être jetée.

### DIRECTIVES D'APPLICATION DES AUTOCOLLANTS

1. Découper l'autocollant désiré de la feuille.
2. Tremper l'autocollant dans de l'eau pendant quelques secondes.
3. Placer l'autocollant mouillé sur une serviette en papier.
4. Attendez que l'autocollant puisse être déplacé sur son support en papier.
5. Mettre l'autocollant en position sur le modèle face sur le dessus et faire glisser le support pour l'enlever.
6. Appuyer avec un chiffon doux humide pour éliminer les bulles d'air.
7. La substance laiteuse qui peut apparaître est destinée à améliorer l'adhésion de l'autocollant et devient incolore au séchage. Essuyer pour enlever tout excédent d'adhésif.
8. Ne pas toucher l'autocollant tant qu'il n'est pas bien sec.
9. Laisser l'autocollant sécher pendant 48 heures avant d'appliquer une couche transparente.

**REMARQUE:** Les autocollants sont compatibles avec les solutions de fixation ou les solvants.

This paint guide is provided to complete this kit as shown on the box.

Ce guide de peinture est fourni pour reproduire le modèle réduit qui apparaît sur la boîte.

Aircraft Gray	FS 16473	Gris avionnet
Aluminum		Aluminium
Blue	FS 15180	Bleu
Chromate Green	FS 34227	Vert chromate
Dark Blue	FS 35042	Bleu foncé
Dark Burnt Metal		Sombre brûlé métal
Dark Green	FS 34079	Vert foncé
Dark Gull Gray	FS 36231	Gris ocre foncé
Flat Black	FS 37038	Noir mat
Flat White	FS 37875	Blanc mat
Flesh		Chair
Gloss Black	FS 17038	Noir lustré
Gloss Dark Green	FS 14090	Vert foncé lustré
Gloss Dark Red	FS 11350	Rouge foncé lustré
Gloss Red	FS 11136	Rouge lustré
Gloss White	FS 17875	Blanc lustré
Gloss Yellow	FS 13538	Jaune lustré
Green	FS 34102	Vert
Light Gray	FS 36440	Gris clair
Olive Drab	FS 34987	Olive
Olive Green	FS 34086	Vert Olive
Sand	FS 30277	Sable
Semi-Gloss Black	FS 27038	Noir satiné
Silver		Argent
Steel		Acier
Tan	FS 30219	Tan
Titanium		Titanium

If you have any questions or comments, call our hotline at: **(800) 833-3570** or, please write to:

Revell-Monogram Consumer Service Department, 8601 Waukegan Road, Morton Grove, Illinois 60053  
Be sure to include the plan number (85551800200), part number, description, your return address and phone number.

Visit our website: [www.revell-monogram.com](http://www.revell-monogram.com)

# 1

# AFTERBURNER ASSEMBLY

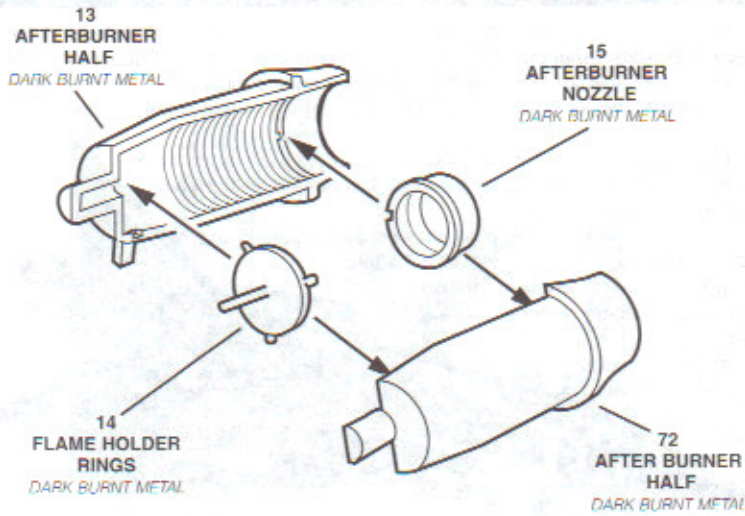

REPEAT FOR OTHER SIDE OF FUSELAGE

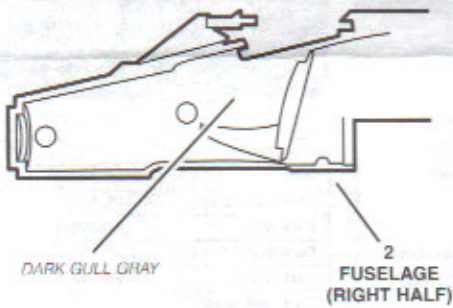

REPEAT FOR OTHER SIDE USING TAIL CONE HALF 86

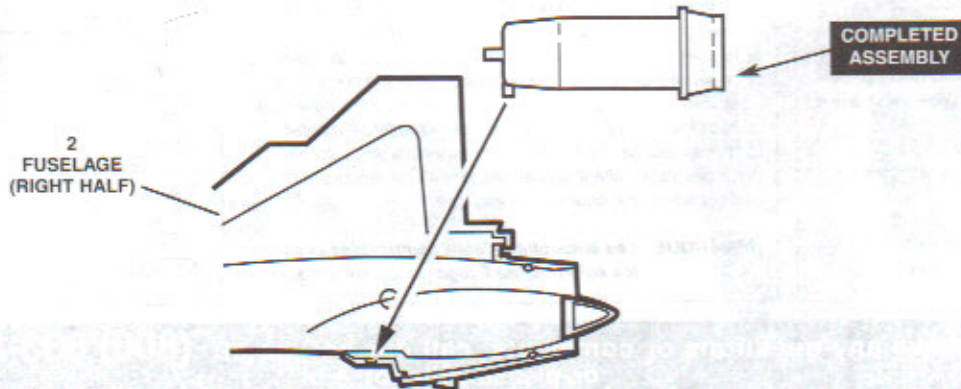
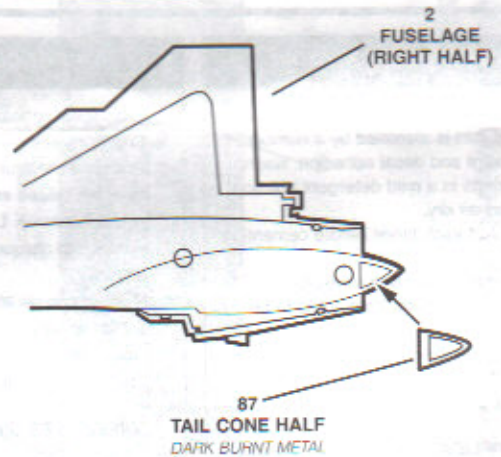

# 2

# FUSELAGE ASSEMBLY

2  
FUSELAGE  
(RIGHT HALF)

1  
FUSELAGE  
(LEFT HALF)

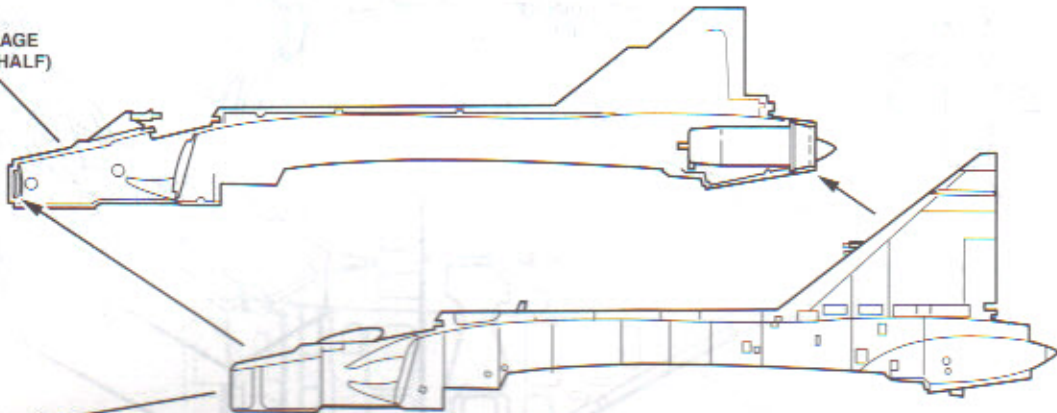

# 3

# COCKPIT ASSEMBLY

19  
COCKPIT  
INTERIOR

DARK GULL GRAY

CHROMATE GREEN  
(BOTTOM)

CHROMATE GREEN

27  
NOSE GEAR WELL

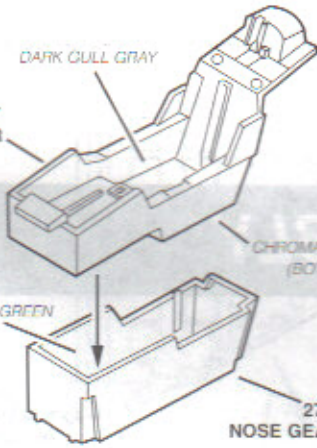

73  
SEAT  
(RIGHT SIDE)  
DARK GULL GRAY  
(PAINT SHADED AREA RED)

PAINT BELTS LIGHT GRAY  
WITH SILVER BUCKLES

23  
EJECTION SEAT  
DARK GULL GRAY

24  
SEAT  
(LEFT SIDE)  
DARK GULL GRAY  
(PAINT SHADED AREA RED)

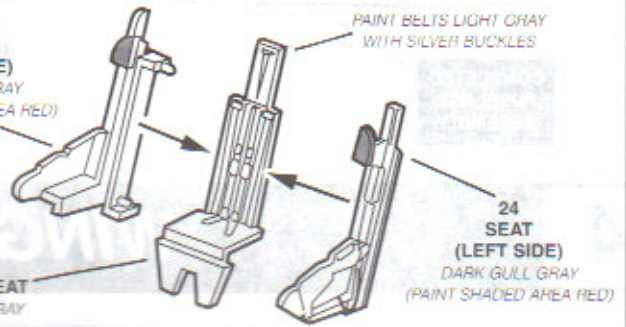

21  
CONTROL COLUMN  
DARK GULL GRAY

FLAT BLACK GRIP

22  
THROTTLE  
FLAT BLACK QUADRANT WITH  
DARK GULL GRAY SIDES

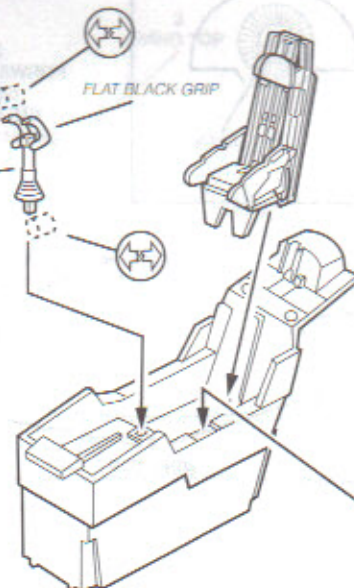

# 3

## COCKPIT ASSEMBLY CONTINUED



20  
INSTRUMENT  
PANEL

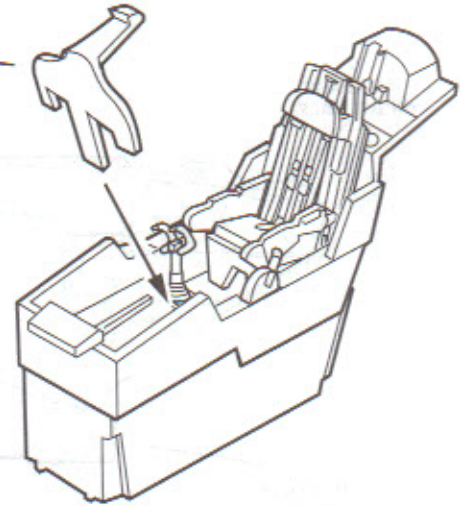

COMPLETED  
FUSELAGE  
ASSEMBLY

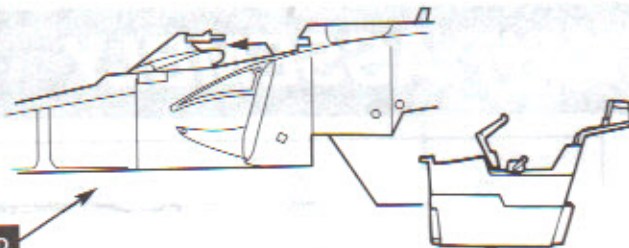

# 4

## WING ASSEMBLY

56  
ENGINE  
BULKHEAD  
CHROMATE GREEN



33  
FORWARD MAIN  
GEAR  
BULKHEAD  
CHROMATE GREEN

34  
AFT MAIN GEAR  
BULKHEAD  
CHROMATE GREEN

CHROMATE GREEN

CHROMATE GREEN

3  
WING TOP

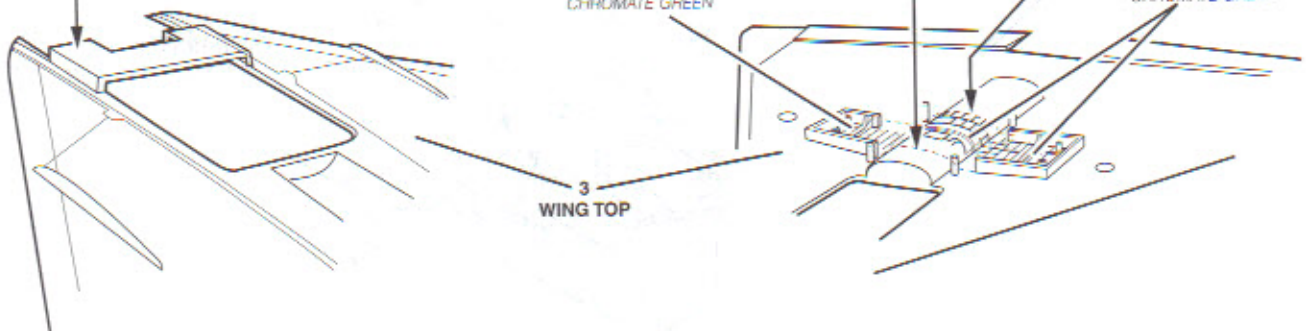

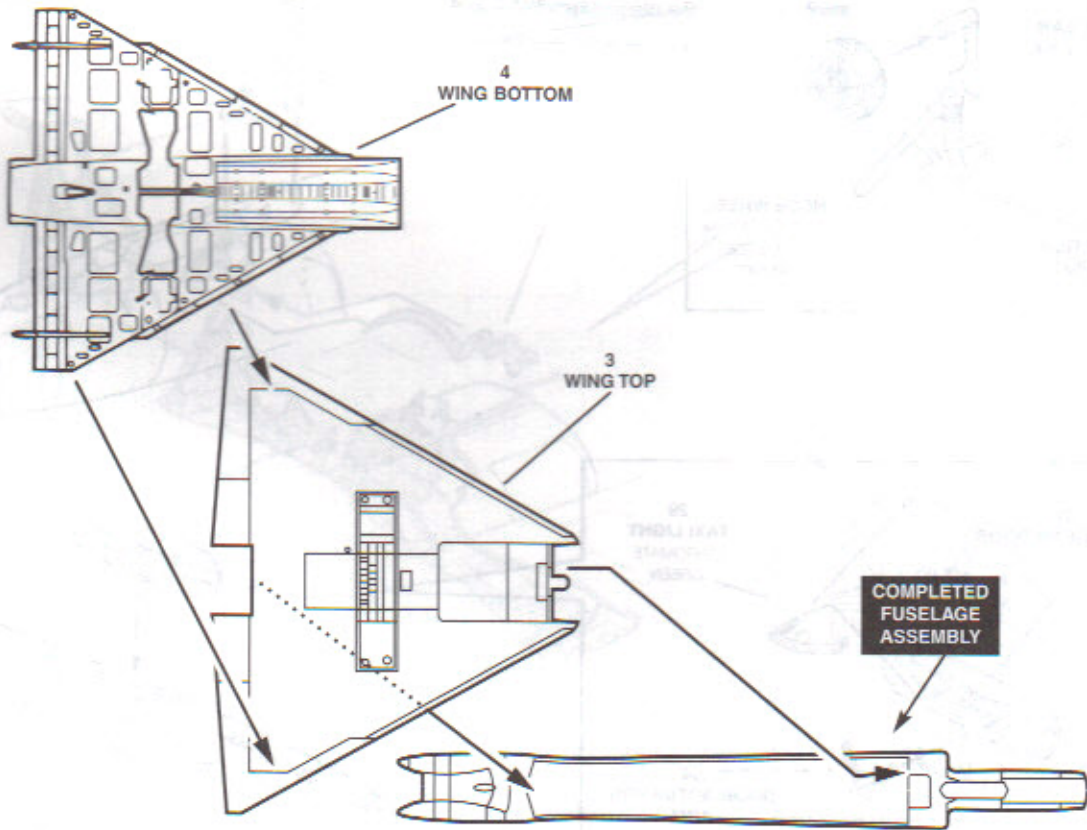
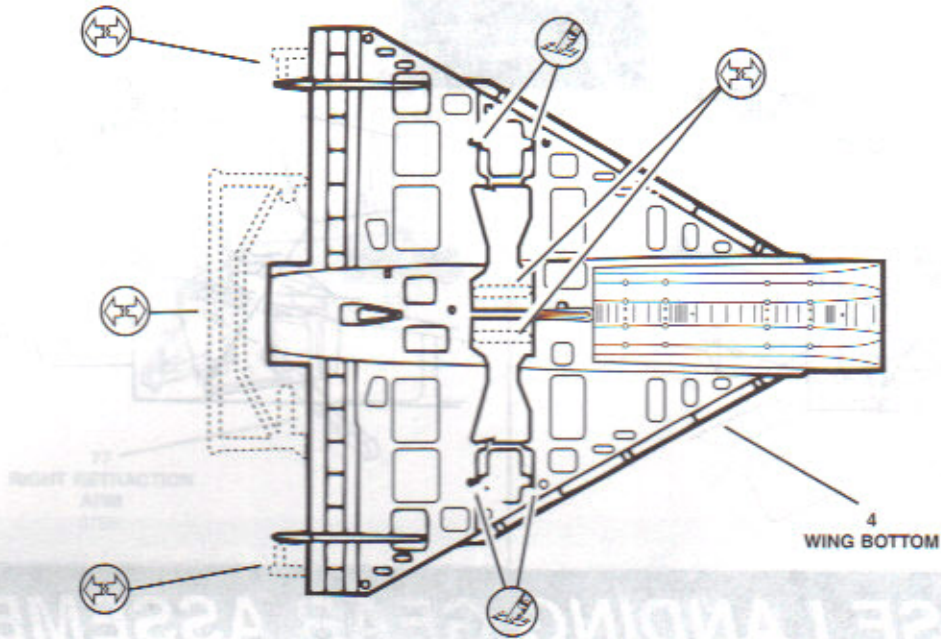

# 5

# ENGINE INTAKE ASSEMBLY

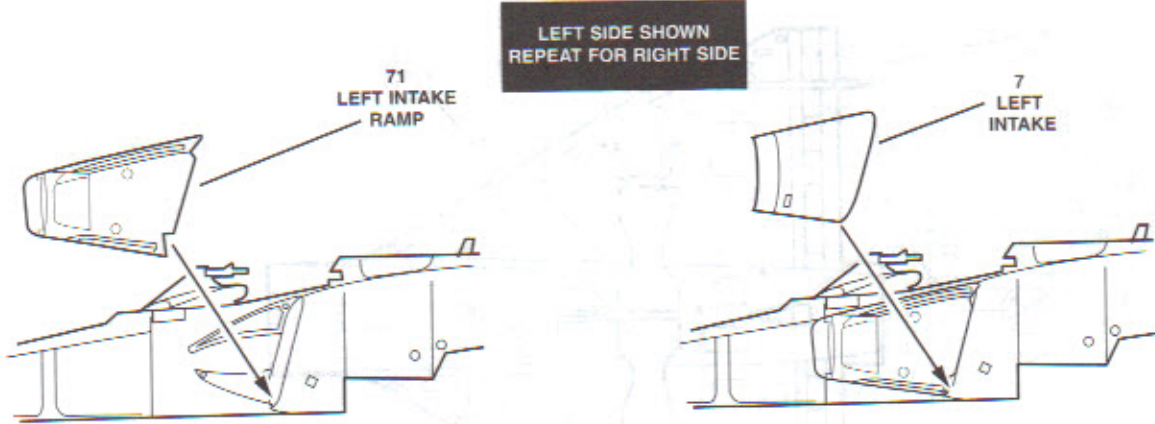

# 6

# NOSE LANDING GEAR ASSEMBLY

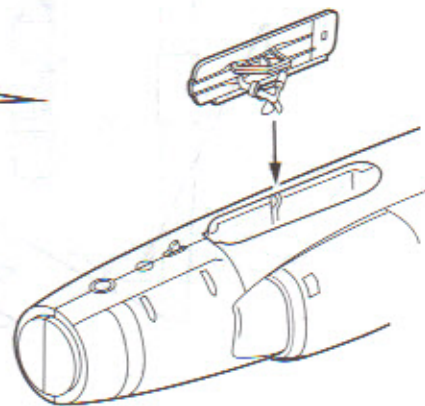
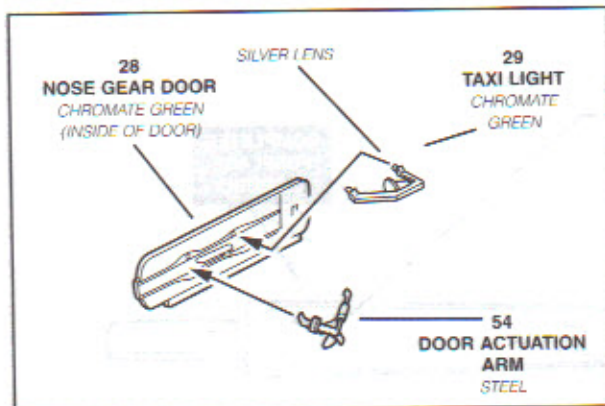
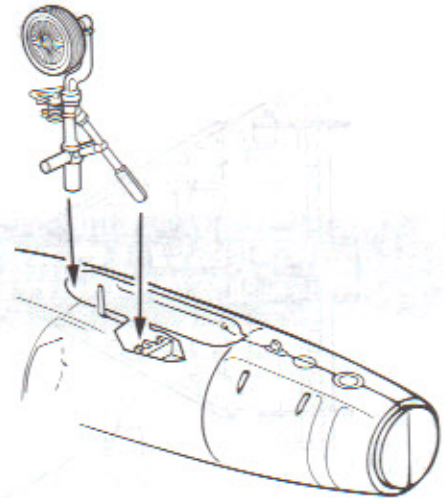
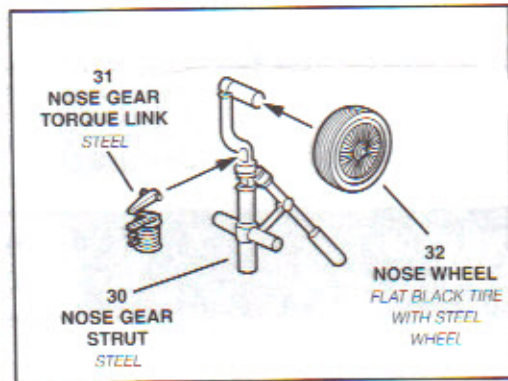

# 7

# MAIN LANDING GEAR ASSEMBLY

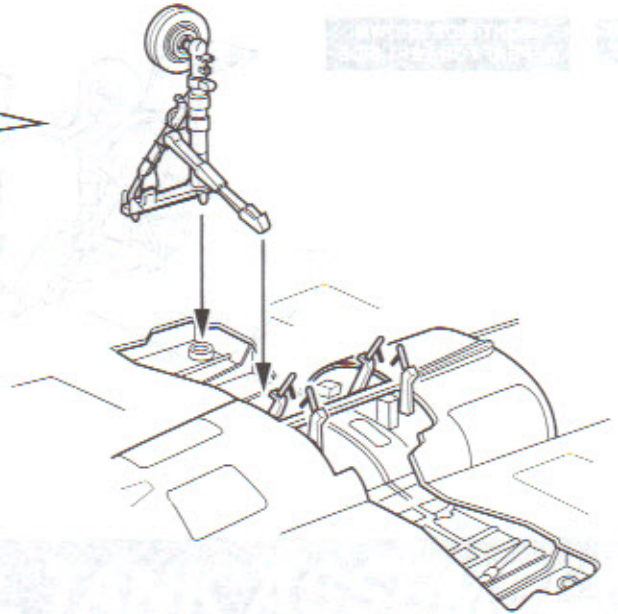
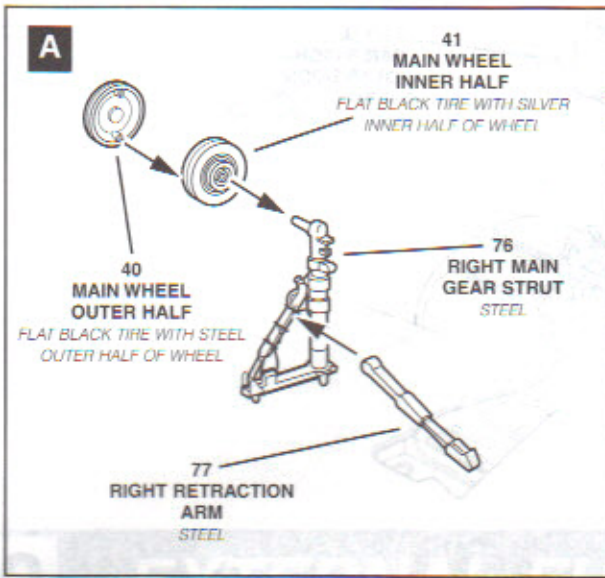

RIGHT SIDE SHOWN  
REPEAT FOR LEFT SIDE

## B

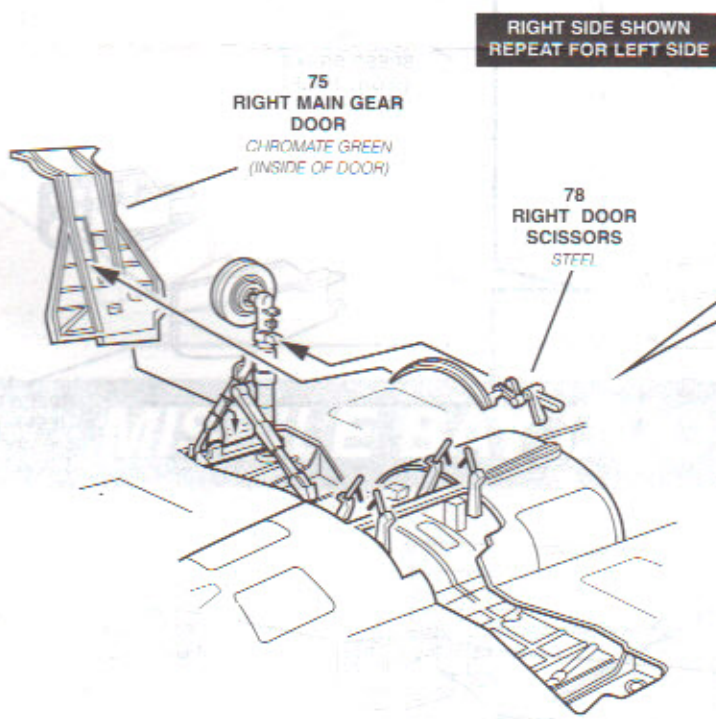

## A



## B

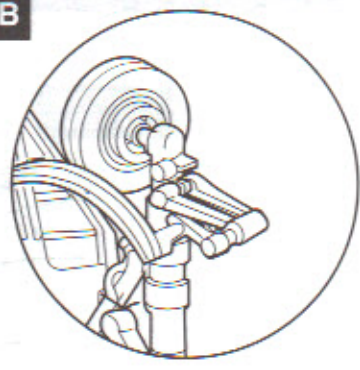

# 7

## MAIN LANDING GEAR CONTINUED

C

RIGHT SIDE SHOWN  
REPEAT FOR LEFT SIDE

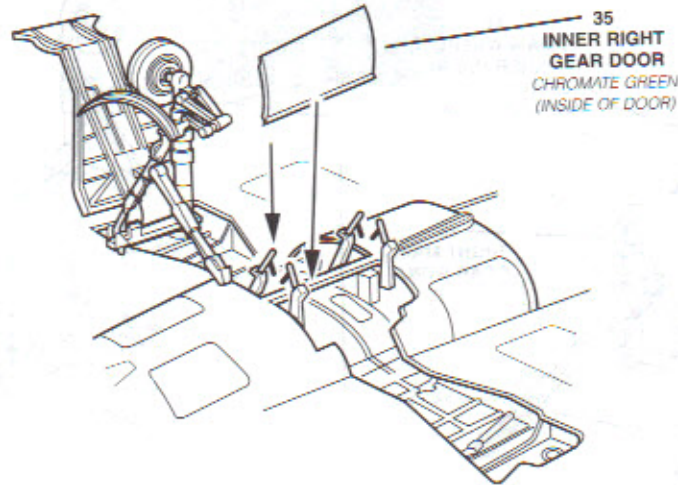

# 8

## SPEED BRAKE ASSEMBLY

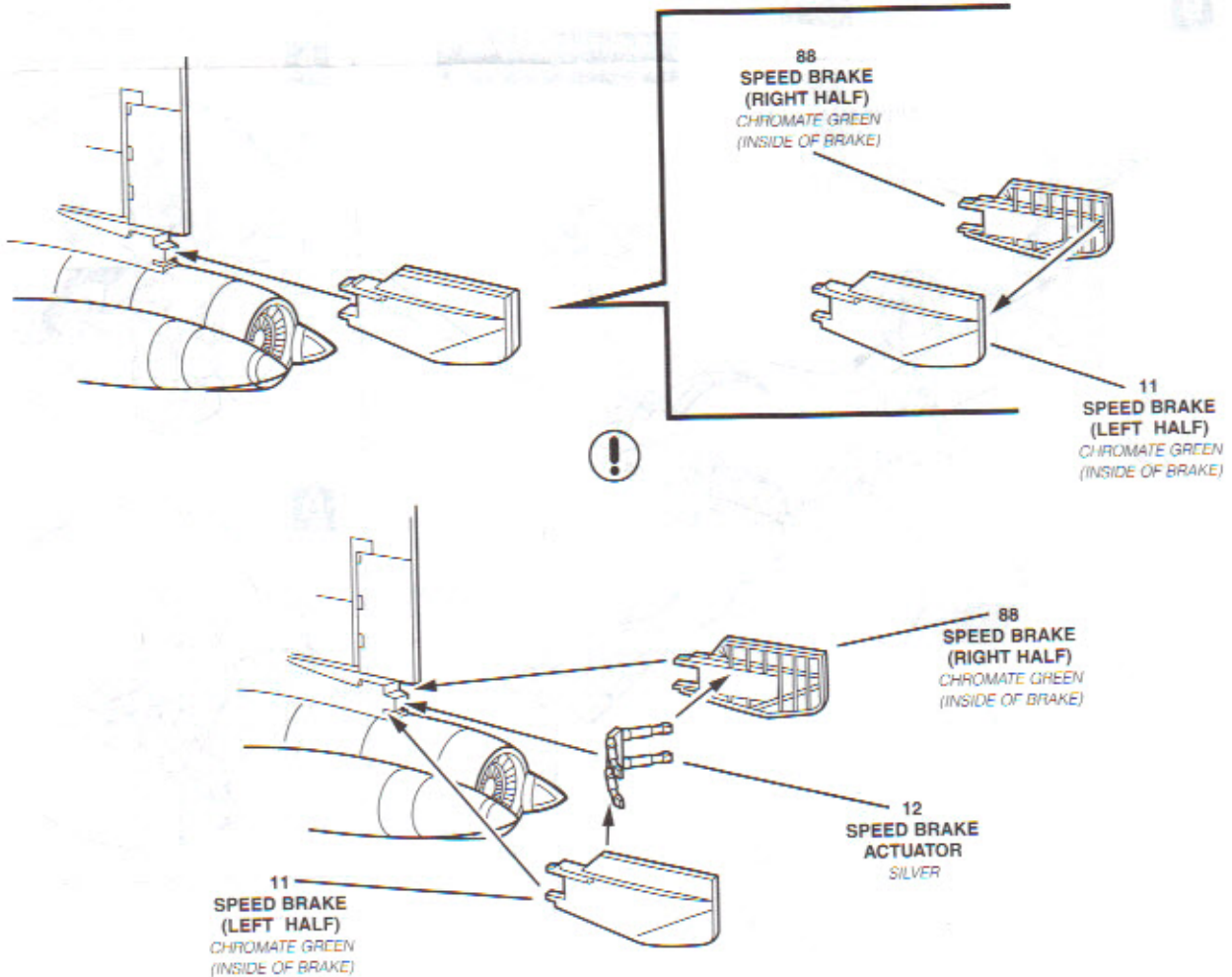



9

# TAILHOOK ASSEMBLY

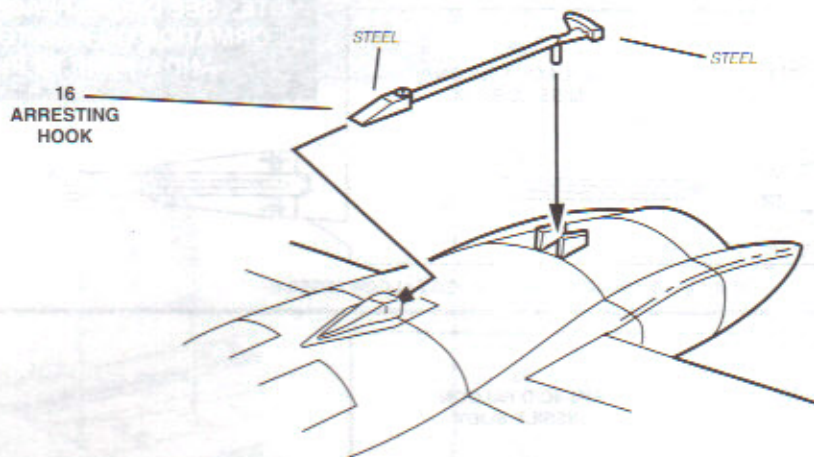

10

# EXTERNAL FUEL TANK ASSEMBLY

2X

9  
EXTERNAL  
FUEL TANK  
(LEFT HALF)

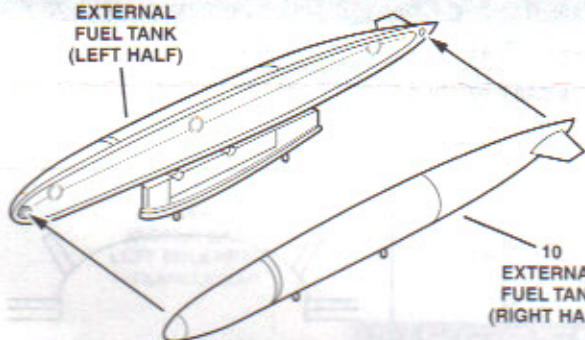

RIGHT SIDE SHOWN  
REPEAT FOR LEFT SIDE

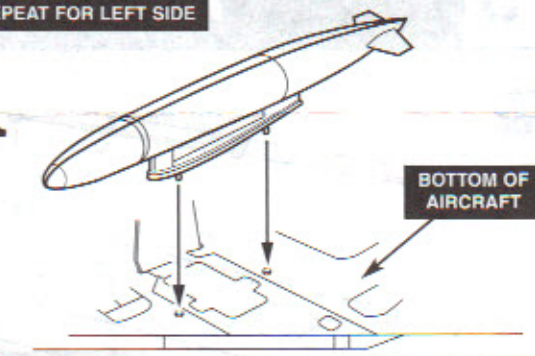

11

# MISSILE BAY DOOR ASSEMBLY

!

42  
MISSILE BAY  
DOORS  
(CLOSED)

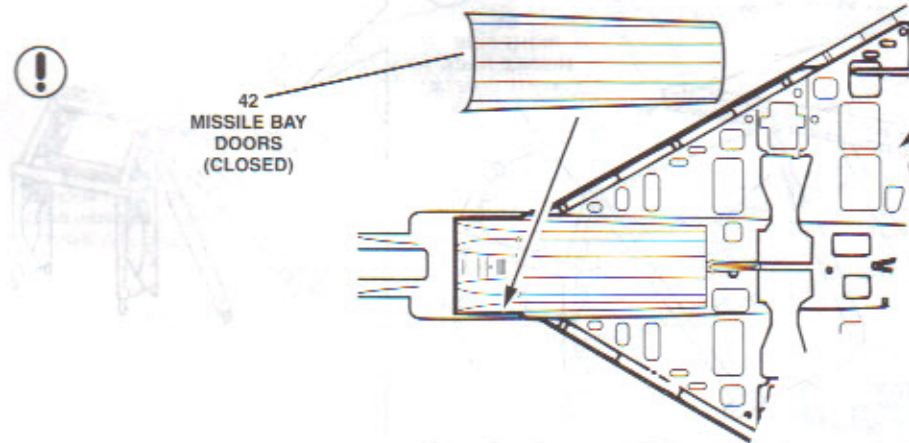

# 12

# FALCON MISSILE ASSEMBLY

NOTE: SEE DECAL PLACEMENT SECTION FOR INFORMATION ON HOW TO PAINT THE MISSILES AND WHERE TO PLACE DECALS

3X

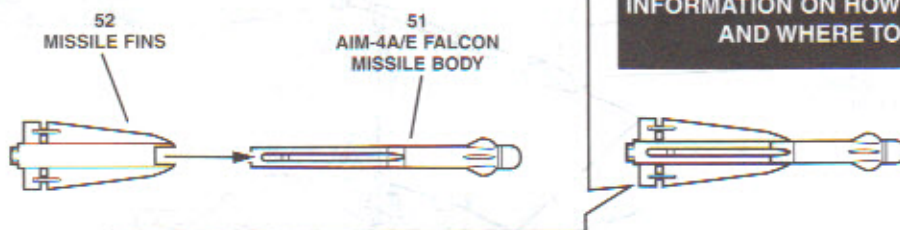

AIM-4A OR AIM-4E RADAR GUIDED FALCON MISSILE

3X

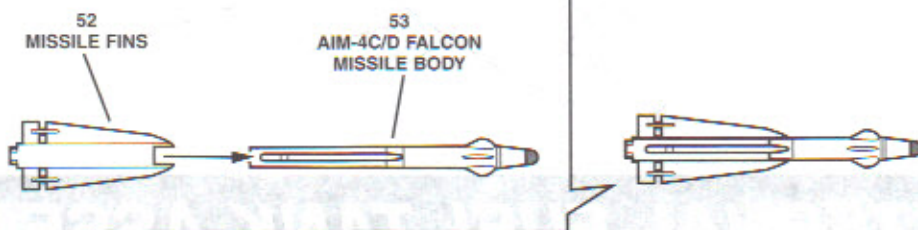

AIM-4C OR AIM-4D INFRARED GUIDED FALCON MISSILE

# 13

# MISSILE BAY ASSEMBLY

A

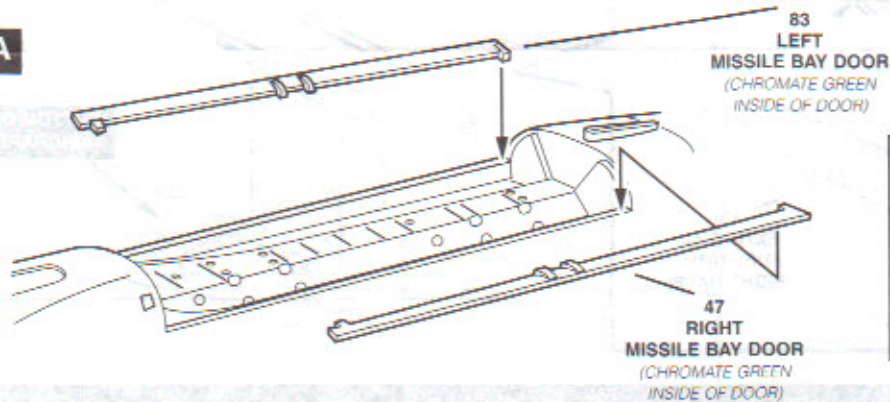

FRONT VIEW SHOWING ANGLES

B

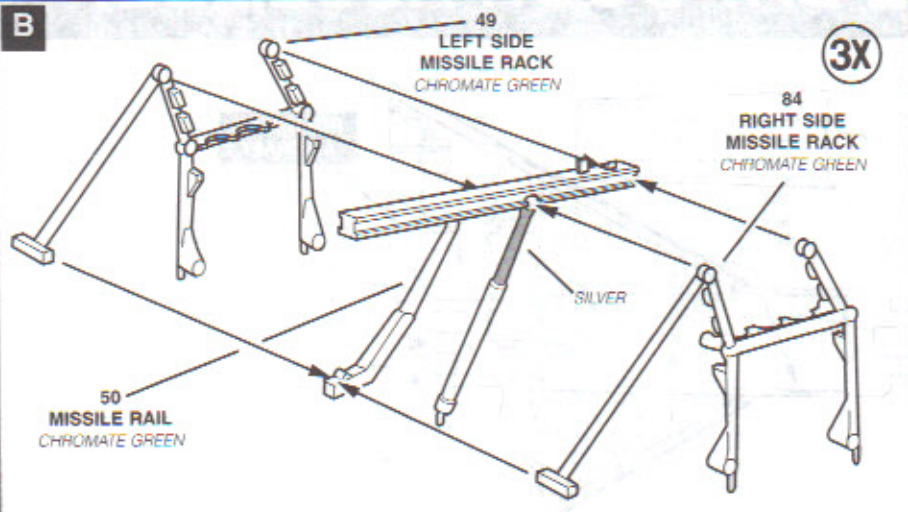

**C**

3X

COMPLETED  
RADAR GUIDED  
MISSILE  
ASSEMBLY

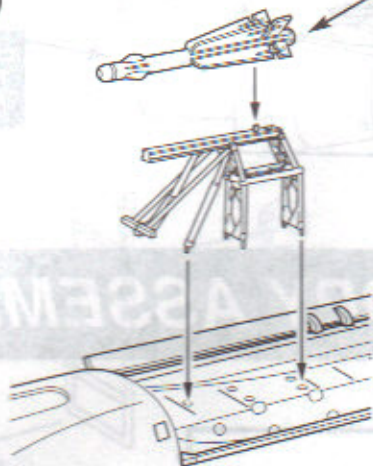

CENTER FORWARD MISSILE RAIL SHOWN  
REPEAT FOR LEFT AND RIGHT FORWARD MISSILE RAILS

3X

COMPLETED  
INFRARED GUIDED  
MISSILE ASSEMBLY

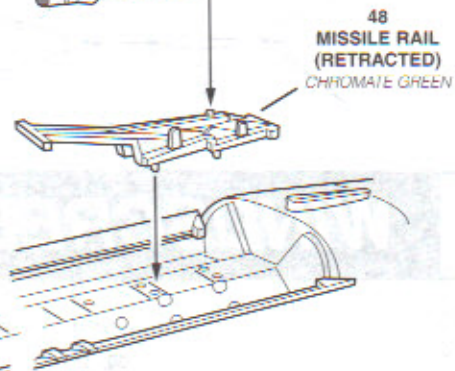

CENTER AFT MISSILE RAIL SHOWN  
REPEAT FOR LEFT AND RIGHT AFT MISSILE RAILS

**D**

44  
MISSILE DOOR  
CHROMATE GREEN

43  
MISSILE BAY  
LEFT BULKHEAD  
CHROMATE GREEN

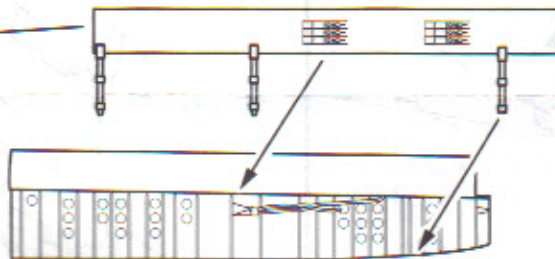

LEFT SIDE BULKHEAD AND DOOR SHOWN  
REPEAT FOR RIGHT SIDE BULKHEAD AND DOOR

**E**

81  
FRONT OF DOORS  
CHROMATE GREEN WITH OLIVE  
DRAB WARHEADS ON ROCKETS  
INSIDE OF LAUNCH TUBES

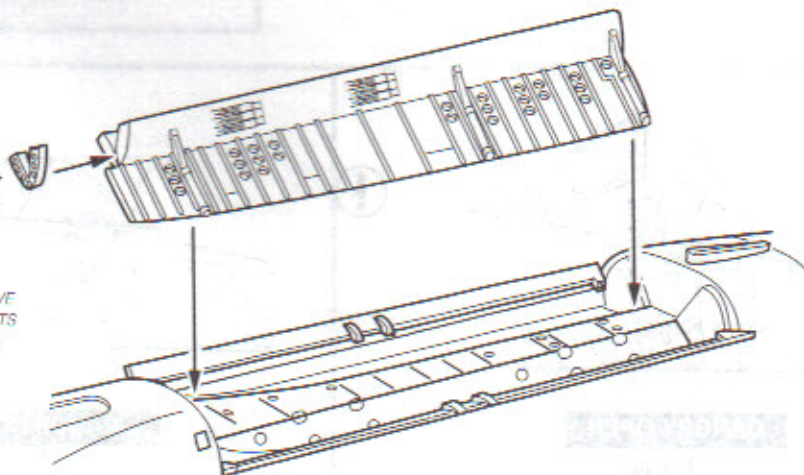

LEFT SIDE SHOWN  
REPEAT FOR RIGHT SIDE

# 14

## RADOME ASSEMBLY

6  
PITOT PROBE  
SEMI-GLOSS  
BLACK

SILVER TIP

5  
RADOME  
SEMI-GLOSS  
BLACK

COMPLETED  
FUSELAGE  
ASSEMBLY

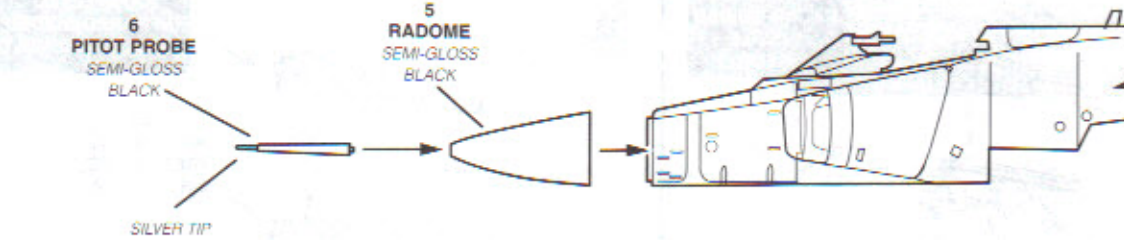

# 15

## WINDSCREEN / CANOPY ASSEMBLY

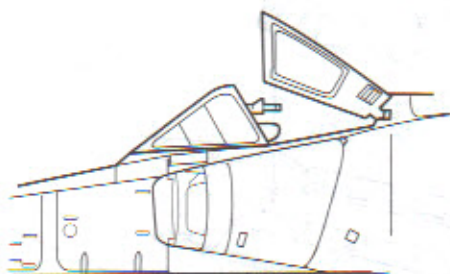
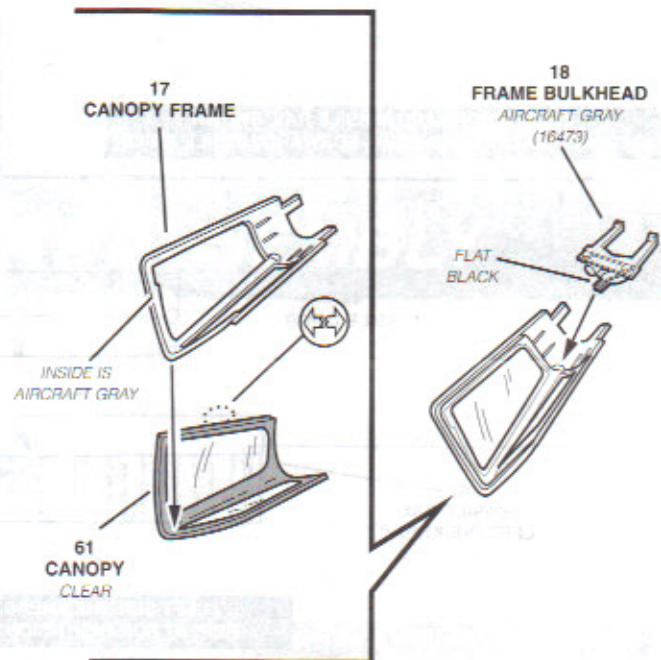
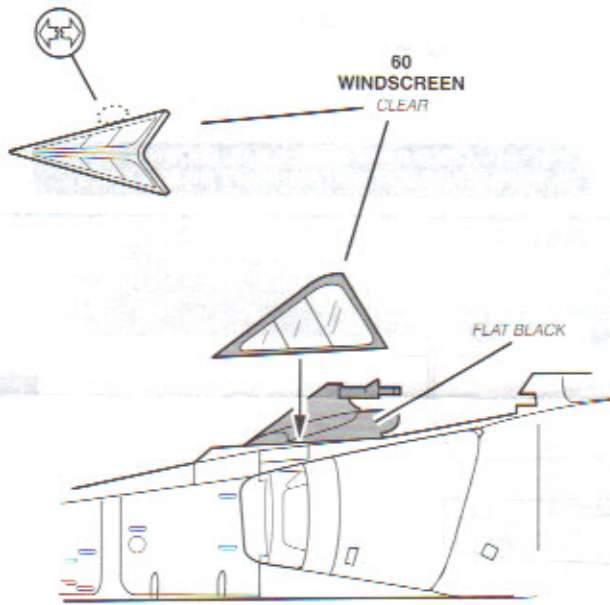

CANOPY OPEN

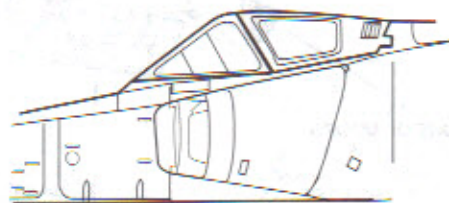

CANOPY CLOSED

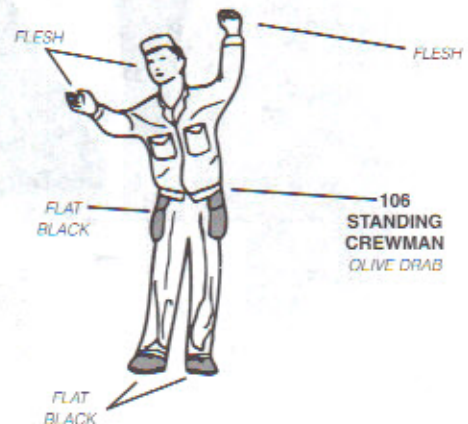
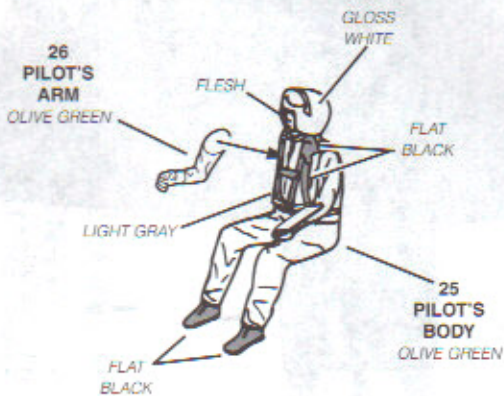
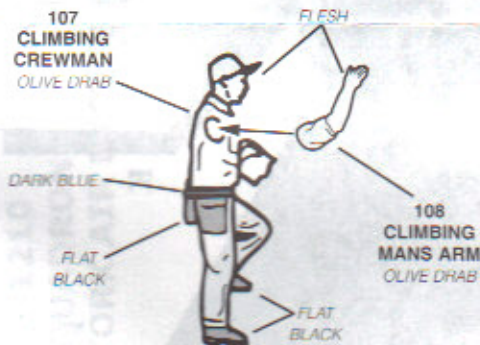
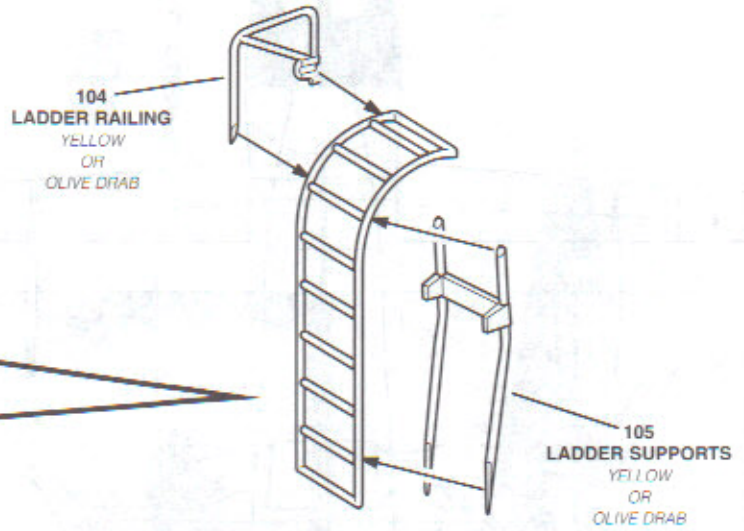
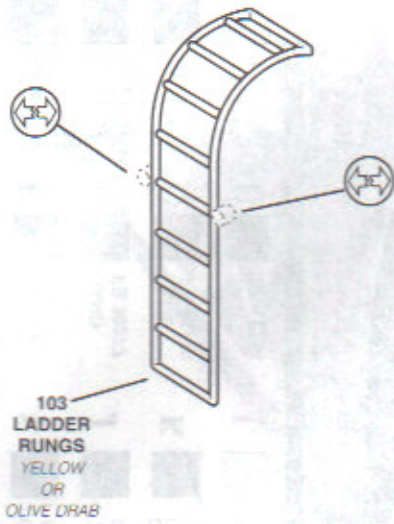

**PAINT COLORS**

<b>A</b>	AIRCRAFT GRAY FS16473	<b>E</b>	BLACK	<b>I</b>	GREEN FS 34102	<b>M</b>	WHITE
<b>B</b>	NATURAL ALUMINUM	<b>F</b>	SAND FS 30277	<b>J</b>	TAN FS 30219	<b>N</b>	CHROMATE GREEN
<b>C</b>	TITANIUM	<b>G</b>	BLUE FS 15180	<b>K</b>	DARK GREEN FS 34079		
<b>D</b>	YELLOW FS13538	<b>H</b>	RED FS 11136	<b>L</b>	LIGHT GRAY FS 36440		

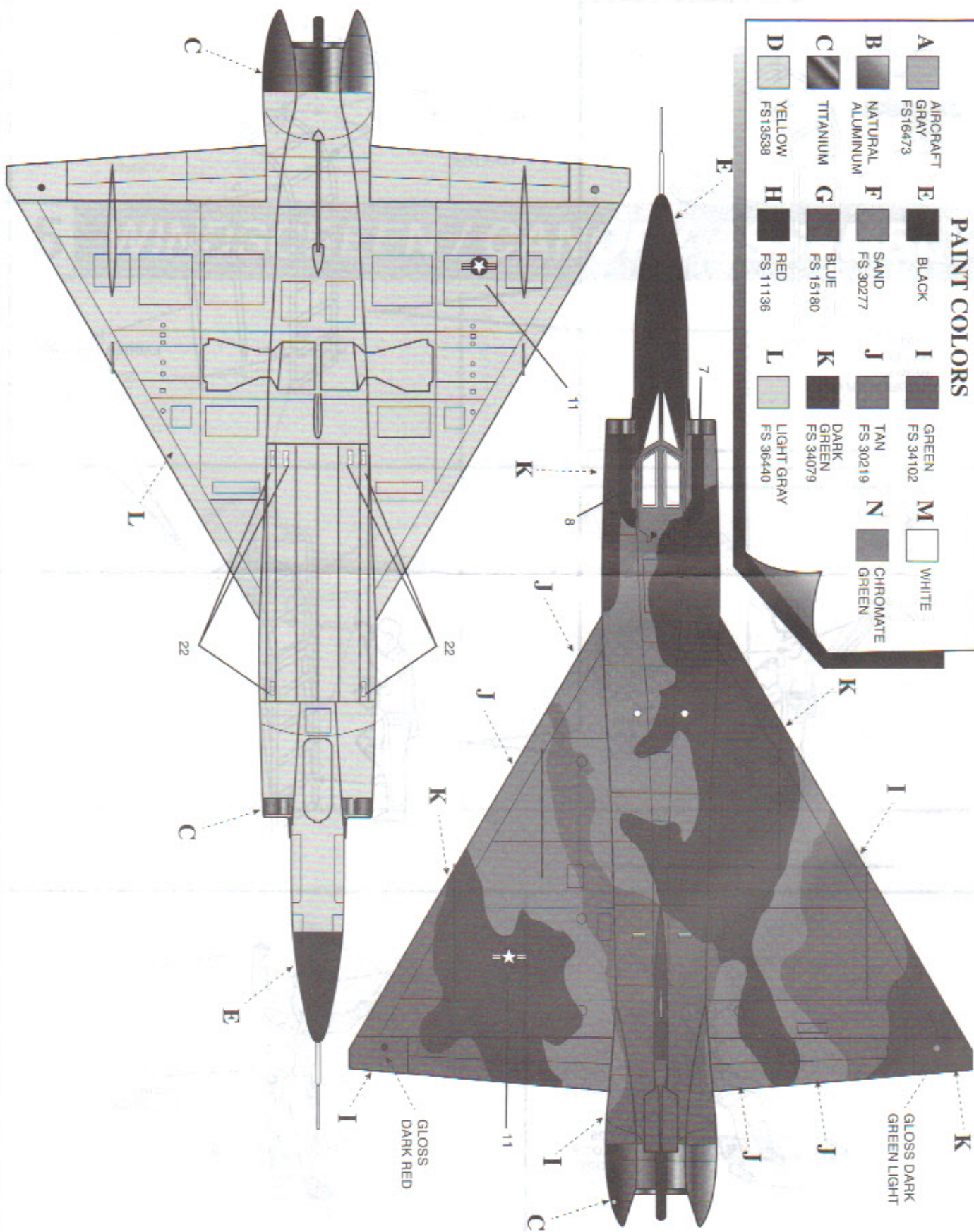

GLOSS DARK RED

GLOSS DARK GREEN LIGHT

**F-102A-70-CO DELTA DAGGER, 56-1210**  
**102<sup>ND</sup> FIGHTER INTERCEPTOR SQUADRON**  
**AIR DEFENSE COMMAND, NEW YORK AIR NATIONAL GUARD**  
**JANUARY 1973**

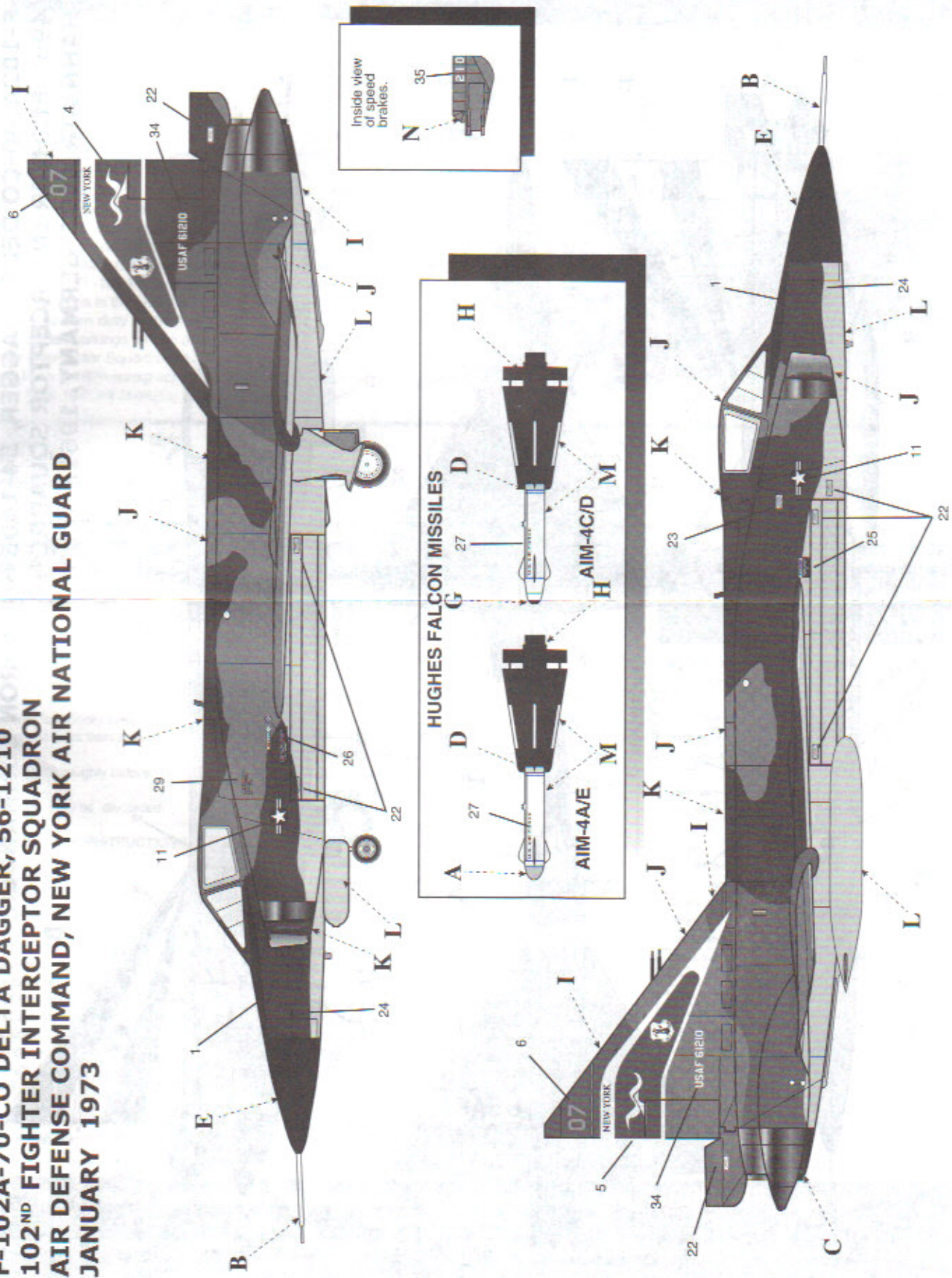

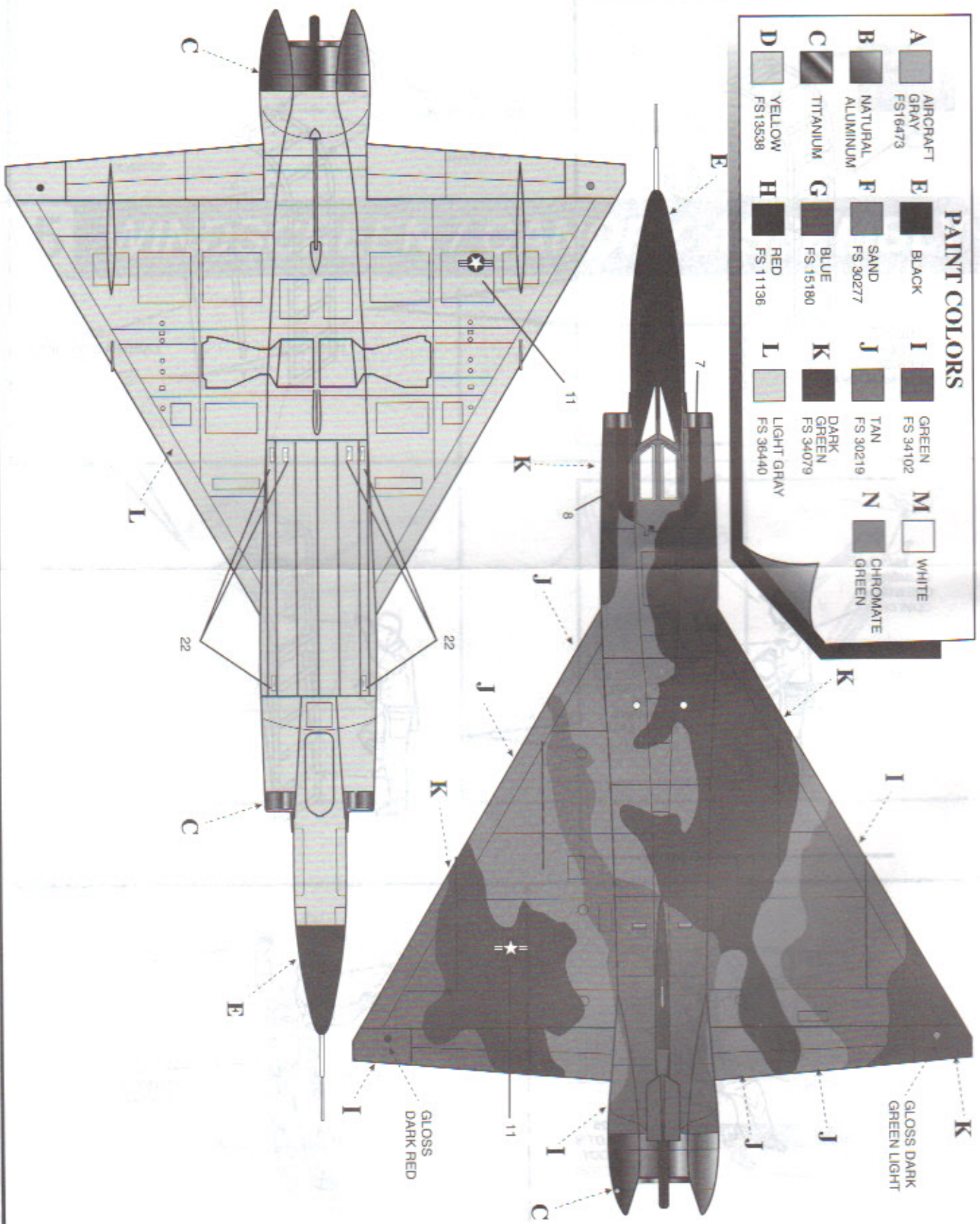

PAINT COLORS

<b>A</b>	AIRCRAFT GRAY FS16473	<b>E</b>	BLACK	<b>I</b>	GREEN FS 34102	<b>M</b>	WHITE
<b>B</b>	NATURAL ALUMINUM	<b>F</b>	SAND FS 30277	<b>J</b>	TAN FS 30219	<b>N</b>	CHROMATE GREEN
<b>C</b>	TITANIUM	<b>G</b>	BLUE FS 15180	<b>K</b>	DARK GREEN FS 34079		
<b>D</b>	YELLOW FS13538	<b>H</b>	RED FS 11136	<b>L</b>	LIGHT GRAY FS 34440		

**K** GLOSS DARK GREEN LIGHT

**I** GLOSS DARK RED



**F-102A-70-CO DELTA DAGGER, 56-1210**  
**102<sup>ND</sup> FIGHTER INTERCEPTOR SQUADRON**  
**AIR DEFENSE COMMAND, NEW YORK AIR NATIONAL GUARD**  
**JANUARY 1973**

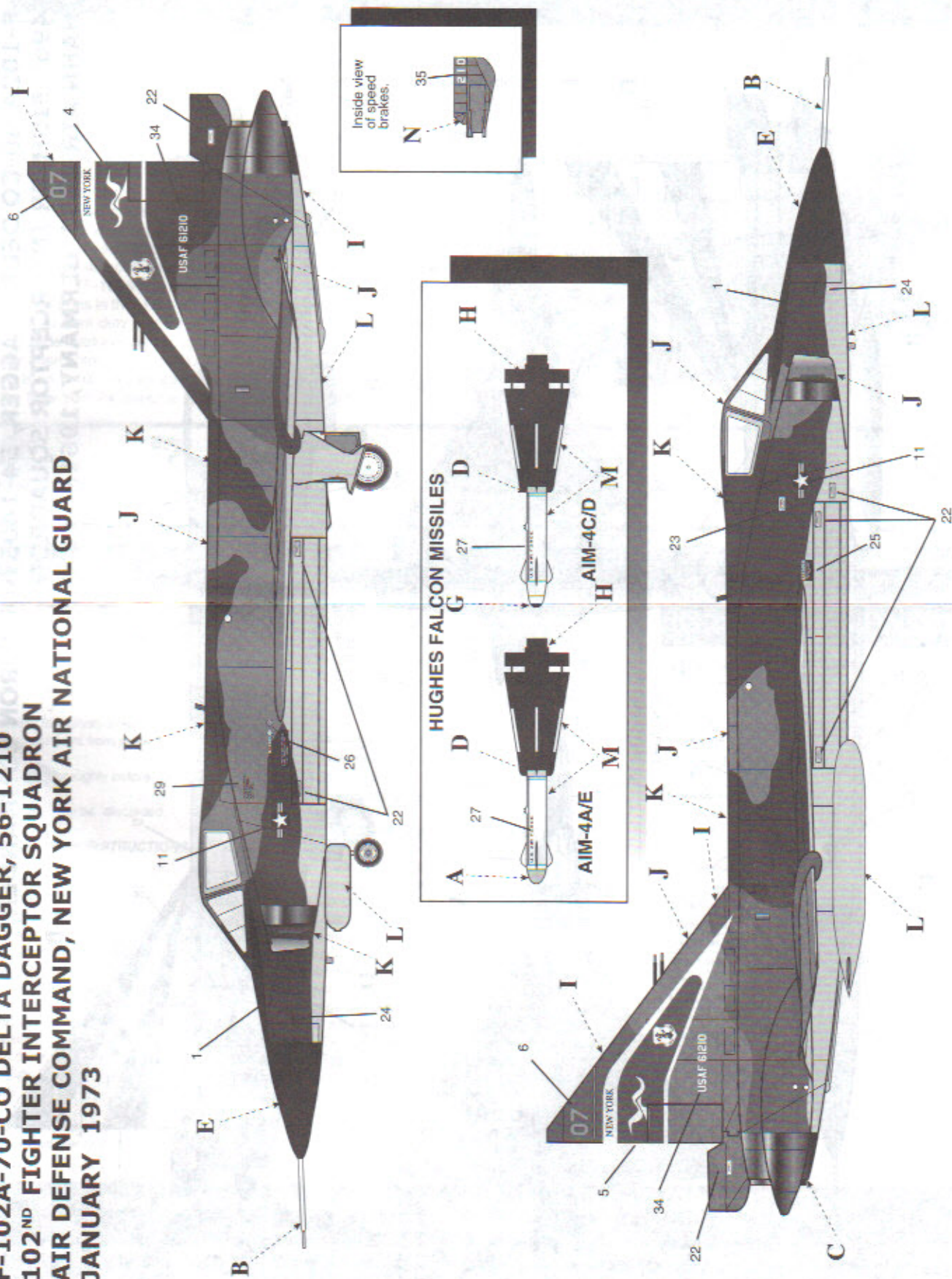

F-102A-40-CO DELTA DAGGER, 54-1405 SQUADRON COMMANDER,  
 496<sup>TH</sup> FIGHTER INTERCEPTOR SQUADRON  
 HAHN AIR BASE, GERMANY, 1961.

