

# Douglas DC-3 Classic Air

# MONOGRAM

74008-0389

© 1991 BY MONOGRAM INC.

PRINTED IN W. GERMANY

**DEUTSCH: ACHTUNG:** Vor dem Zusammensetzen die Bauanleitung gut durchlesen. Jedes Teil ist nummeriert. Reihenfolge der Montageschritte beachten. Benötigte Werkzeuge: Messer und Feile zum Entfernen und Entgraten der Teile, Gummiband, Klebeband und Wäscheklammern zum Zusammenhalten der geklebten Einzelteile. Plastikteile in einer milden Waschlösung reinigen und an der Luft trocknen, damit der Farbstrich und die Abziehbilder besser haften. Vor dem Ankleben prüfen, ob die Teile passen; Klebstoff sparsam auftragen. Chrom und Farbe an den Klebeflächen entfernen. Kleine Teile anstreichen, bevor sie vom Rahmen entfernt werden. Farben gut durchtrocknen lassen, erst dann den Zusammenbau fortsetzen. Jedes Abziehbildmotiv einzeln ausschneiden und ca. 20 Sekunden in warmes Wasser tauchen. Das Motiv an der bezeichneten Stelle vom Papier abschieben und mit Löschpapier andrücken.

**ENGLISH: ATTENTION:** Carefully read instruction sheet before assembling. Each part is numbered. Consider succession of assembly steps. Required tools: knife and file to remove and trim parts; rubber band, adhesive tape and clothes pegs to hold parts after cementing. Wash plastic in mild detergent solution, rinse and let air dry for better paint and decal adhesion. Scrape chrome and paint at area to be glued: Paint small parts on runner before removing. Allow paint to dry thoroughly before continuing assembly. Cut out each decal one by one and dip it in warm water for approx. 20 secs.; slide decal from the paper at the marked position and dab with blotting-paper.

**FRANCAIS: ATTENTION:** lire soigneusement la fiche d'instructions avant d'assembler. Chaque pièce est numérotée. Suivre la succession des étapes de montage. Outils nécessaires: couteau et lime pour détacher et ébarber les pièces, élastiques, papier adhésif et pinces à linge pour maintenir ensemble les pièces après collage. Laver le plastique dans une solution détergente légère, rincer et laisser sécher à l'air libre pour une meilleure adhérence de la peinture et des décalés. Ajuster les pièces ensemble avant de coller. Employer la colle Revell pour plastique exclusivement. Utiliser très peu de colle à chaque fois. Gratter le chrome ou la peinture sur les surfaces à coller. Peindre les petites pièces sur le support avant de les détacher. Laisser la peinture sécher totalement avant de continuer l'assemblage. Découper chaque décal séparément et le plonger dans l'eau chaude environ 20 secondes. Faire glisser le décal du papier à l'endroit du décor et tamponner avec du papier buvard.

**NEDERLANDS: OPGELET:** Alvorens te beginnen met het in elkaar zetten, eerst de handleiding goed doorlezen. Elk onderdeel is genummerd. Aandacht besteden aan de volgorde van montage. Het benodigde gereedschap: mesje en vijl voor het verwijderen en het afbramen van de onderdelen, elastiek, plakband en wasknijpers gebruiken voor het bij elkaar houden van de gelijmde onderdelen. De plastic onderdelen met een zacht wasmiddel schoonmaken en laten drogen zodat de verf en de transfers beter hechten. Alvorens te lijmen, eerst vaststellen of de onderdelen

passen; de lijm zuinig opbrengen. Chrom en verf van de op elkaar te lijmen delen verwijderen. Kleine onderdelen voren voor deze van het gietraam verwijderd worden. De verf goed laten drogen en eerst dan verder gaan met de bouw. Elk transfer apart uitknippen en ca. 20 seconden in lauw/warm water leggen. Het transfer op de juiste plaats van het papier schuiven op het model en met vloeipapier aandrukken.

**SVENSKA: VIKTIGT:** Läs noggrant igenom instruktionerna innan du börjar bygga. Varje del är numrerad. Tänk igenom ordningsföljden för de olika momenten. Följande verktyg krävs: kniv och fil för att ta loss och putsa detaljerna, gummiband, tejp och klädnyppor för att hålla detaljerna på plats medan limmet torkar. Tvätta alla plastdetaljerna i mild tvålösning, skölj och låt lufttorka för att få färg och dekalerna att fästa bättre. Proppassa alltid detaljerna innan du limmar. Använd endast Revells plastlim. Använd sparsamt med lim. Skrapa bort krom och färg från den yta som ska limmas: måla smådetaljerna innan du skär loss dem. Låt all färg torka ordentligt innan du fortsätter byggandet. Skär ut varje dekal för sig och blöt den i ljummet vatten i ungefär 20 sekunder, och låt dekalen glida av papperet och ner på det markerade läget: sug sedan försiktigt upp det mesta lättmed löskpapper eller en tygtrasa.

**ITALIANO: Attenzione:** Leggere attentamente le istruzioni prima dell'assemblaggio. Ogni pezzo è numerato. Tener presente la successione delle fasi di assemblaggio. Attrezzi necessari: coltello e lima per rimuovere e rifinire le parti elastiche nastro adesivo e spilli per tenere le parti dopo averle incollate. Lavare la plastica con un detergente delicato, sciacquare e lasciar asciugare all'aria per una migliore adesione della vernice e delle 'decal'. Accoppiare le parti da incollare. Usare solamente 'Revell plastic cement'. Usare poco collante. Grattare la cromatura e la vernice nei punti da incollare. Dipingere i piccoli accessori sul supporto prima di rimuoverli. Far seccare bene la vernice prima di continuare nell'assemblaggio. Ritagliare una per una le 'decal' ed immergerle in acqua tiepida per circa 20 secondi. Applicare ogni 'decal' nella posizione segnata e tamponare con della carta assorbente.

**ESPAÑOL: ATENCIÓN:** cuidadosamente lean la hoja de instrucciones antes del montaje. Cada pieza es numerada, consideren la sucesion de las operaciones de montaje. Herramientas requeridas: cuchilla y lima para quitar y desbarbar las piezas, banda de caucho, cinta adhesiva y pinzas para sujetar las piezas, despues de engomarias. Lavar el plastico en solucion detergente suave, aclarar y dejar que se seque al aire para una mejor adhesion de la pintura y la calcomania. Adaptar las piezas bien juntas antes de encolar. Solamente utilizar pegamento plastico Revell. Utilizar el pegamento cuidadosamente y sin exceso. Raspar el cromado y la pintura en la zona que ha de ser encolada: Pintar las piezas pequeñas giratorias antes de sacarlas. Dejar que la pintura se seque totalmente antes de continuar el montaje. Cortar cada calcomania una por una y sumergirla en agua caliente durante aproximadamente 20 segundos. Deslizar la calcomania del papel en la posición marcada y golpearla suavemente con el papel secante.

Form hergestellt und im Eigentum von Monogram Inc., USA  
Widerrechtliche Nachahmungen werden gerichtlich verfolgt.  
Mould produced by and the property of Monogram Inc., USA  
Unlawful imitations will be subject to prosecution.

Forme produite par et propriété de Monogram Inc., USA  
Les contrefaçons seront poursuivies par voies légales.  
Vorm vervaardigd door en eigendom van Monogram Inc., USA  
Onrechtmatige nabootsing worden gerechtelijk vervolgd.



Kleben  
Glue  
A coller  
Lijmen  
Limmas  
Incollare  
Engomar



Nicht kleben.  
Don't glue.  
A ne pas coller.  
Niet lijmen.  
Timmas ej.  
Non incollare.  
No engomar.



Anzahl der Arbeitsschritte.  
Number of working steps.  
Nombre d'étapes de travail  
Het aantal der bouwhandelingen.  
Antal arbetsmoment.  
Numero di passaggi.  
Numero de operaciones de trabajo.



Wahlweise  
Optional  
Facultatif  
Ter keuze  
Valfrtt  
Facoltativo  
Opcional



Abziehbild in Wasser einweichen und anbringen.  
Soak and apply decals.  
Mouiller et appliquer les décalés.  
Transfer in water even laten weken en opbrengen.  
Blot and fast dekalerna.  
Immergere in acqua ed applicare decal.  
Remojar y aplicar las calcomanias.



Abbildung zusammengebaute Teile.  
Shown assembled.  
Vu assemble.  
Afbeelding van een gebouwde onderdeel.  
Visaš hopsatt.  
Figura asamblata.  
Presentado montado.



Chromteile  
Chromparts  
Pièces de chrome  
Chroom onderdelen  
Au cromen detailjer  
Parte il cromo  
cromo las piezas



Klarsichtteile  
Clear parts  
Pièces transparentes  
Transparante onderdelen  
Genomskinliga detaljer  
Parte trasparente  
Limpiar las piezas



Remove and throw away  
Entfernen (Abfall)  
Ouite y tire  
Verwijderen en weggooiden  
A retirer et jeter  
Avlagnas og makuleras  
Rimouvi ed elimina

Für den Zusammenbau / Bemalung empfehlen wir Revell / Monogram-Kleber und Revell-Farben.  
For assembling and painting your model we recommend Revell / Monogram and Revell paints.  
Pour l'assemblage et la décoration, nous recommandons la colle Revell / Monogram et les peintures Revell.

Voor het samenstellen en beschilderen bevelen wij Revell / Monogram lijm en Revell verf aan.  
Per l'assemblaggio e la pittura consigliamo collante Revell / Monogram e colori Revell.  
Para el montaje y pintado aconsejamos pegamento Revell / Monogram y colores Revell.  
För hopsättning och målning rekommenderar vi Revell / Monogram lim och Revell färger.

<b>A</b> WHITE WEISS 4 BLANC WIT VIT BIANCO	<b>B</b> MATT BLACK MATT SCHWARZ 8 NOIR MAT MAT ZWART MATT ZWART NERO SMORTO	<b>C</b> FIERY RED FEUERROT 31 ROUGE VERMILLON VUURROOD ELDRÖD ROSSO ACCESO	<b>D</b> ALUMINIUM ALUMINIUM 99 ALUMINIUM ALUMINIUM ALUMINIUM ALUMINIUM	<b>E</b> METALLIC GREY EISENFARBIG 91 GRIS METALLIQUE IJZERKLEUR JARGNRA FERRO	<b>F</b> BLACK SCHWARZ 302 NOIR ZWART SWART NERO	<b>H</b> LIGHT GREY HELLGRAU 371 GRIS CLAIR VAALGRUIS LJUSGRA GRIGIO CHIARO
---	--	---	---	--	--	---

<b>I</b> SILVER SILBER 90 ARGENT ZILVER SILVER ARGENTO	<b>nicht benötigte Teile:</b> 74, 174, 87, 77, 78, 103, 2 x 80, 9 x 100, 3 x 104, 3 x 105, 3 x 106
--	--

Should you find any missing parts, please write to REVELL AG, 2609 + 2620, department X, D-4980 Bünde, W. Germany, and we will send you these as quickly as possible with our compliments. Please indicate clearly with a cross on the instruction leaflet, which piece(s) are missing. Always remember to write your name and address clearly and in full.  
Zou het voorkomen, dat er een deel in de bouwdoos ontbreekt, kunt u schrijven naar REVELL AG, Postbus 2609 + 2620, Afdeling X, D-4980 Bünde. De bouwbeschrijving waarop het ontbrekende deel aangekruist is, sluitsluiten, anders kunnen wij u dit onderdeel niet vergoeden. Vergeet vooral niet uw naam en adres duidelijk te vermelden.  
Pour toute pièce manquante, écrivez à REVELL AG, Postbus 2609 + 2620, département X, D-4980 Bünde, et cet élément vous sera aussitôt envoyé et ce, gratuitement. Il vous suffit dans ce cas de marquer d'une croix la pièce manquante sur la feuille d'instruction du modèle choisi. N'oubliez surtout pas d'écrire clairement votre nom et adresse.

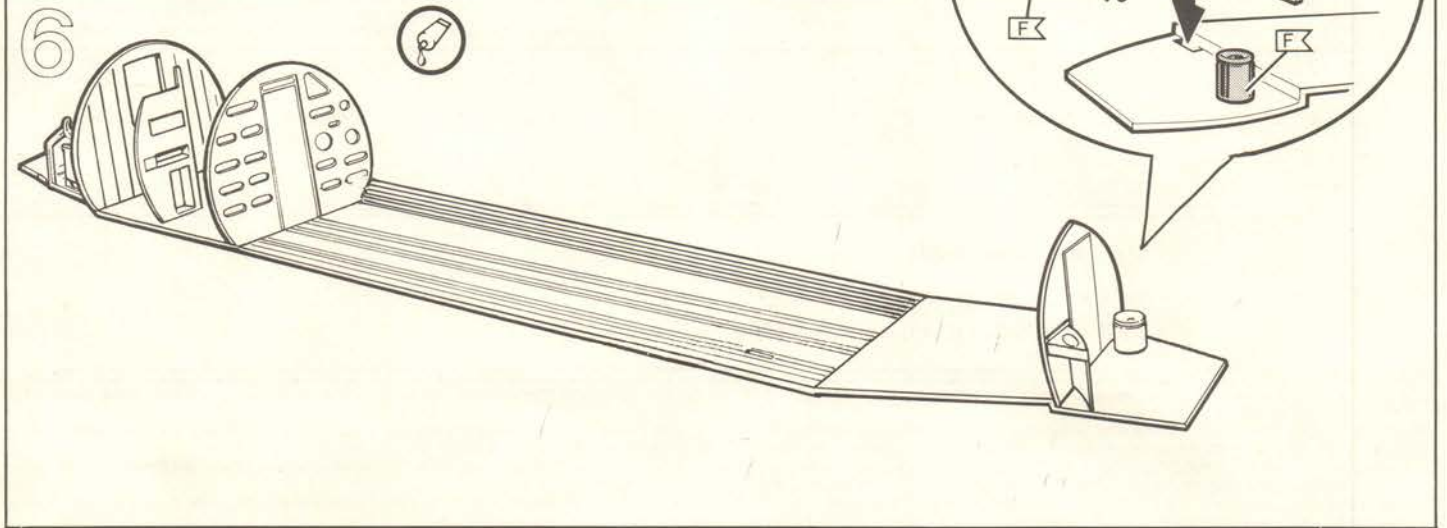
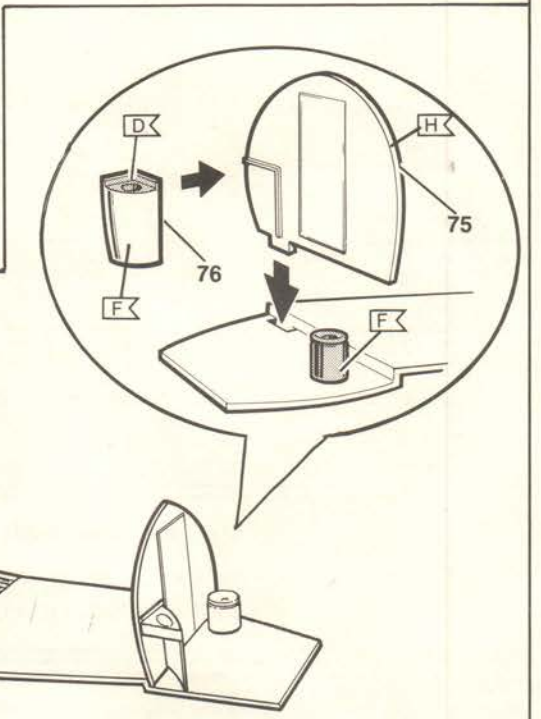
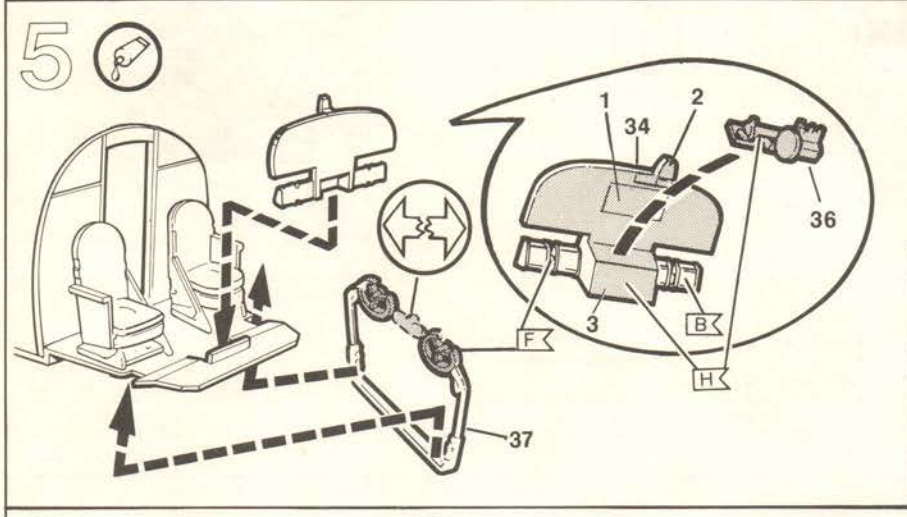
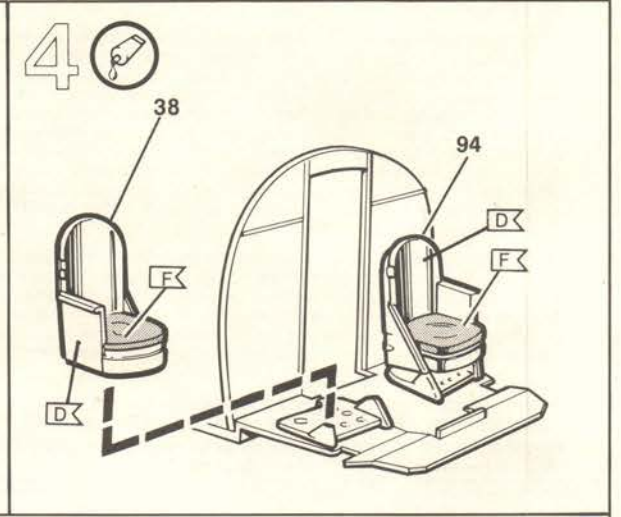
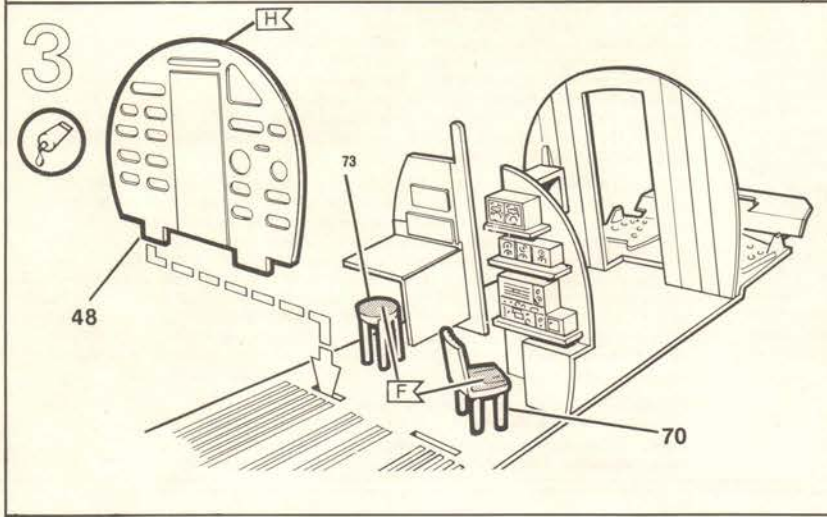
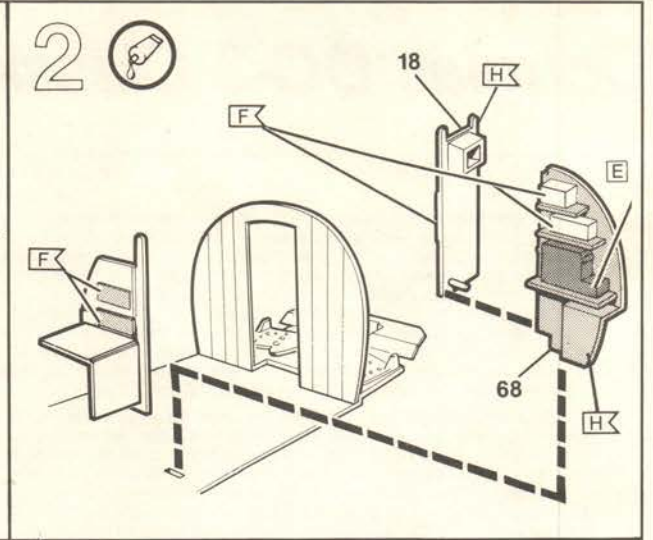
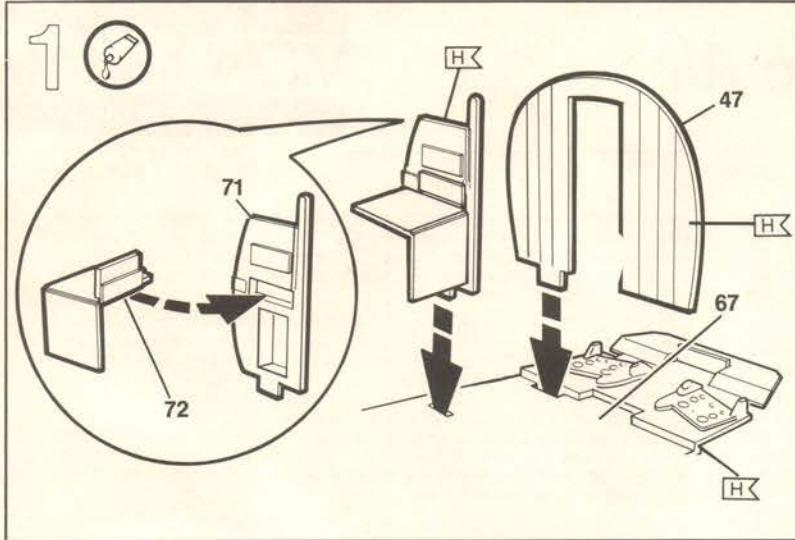

7  

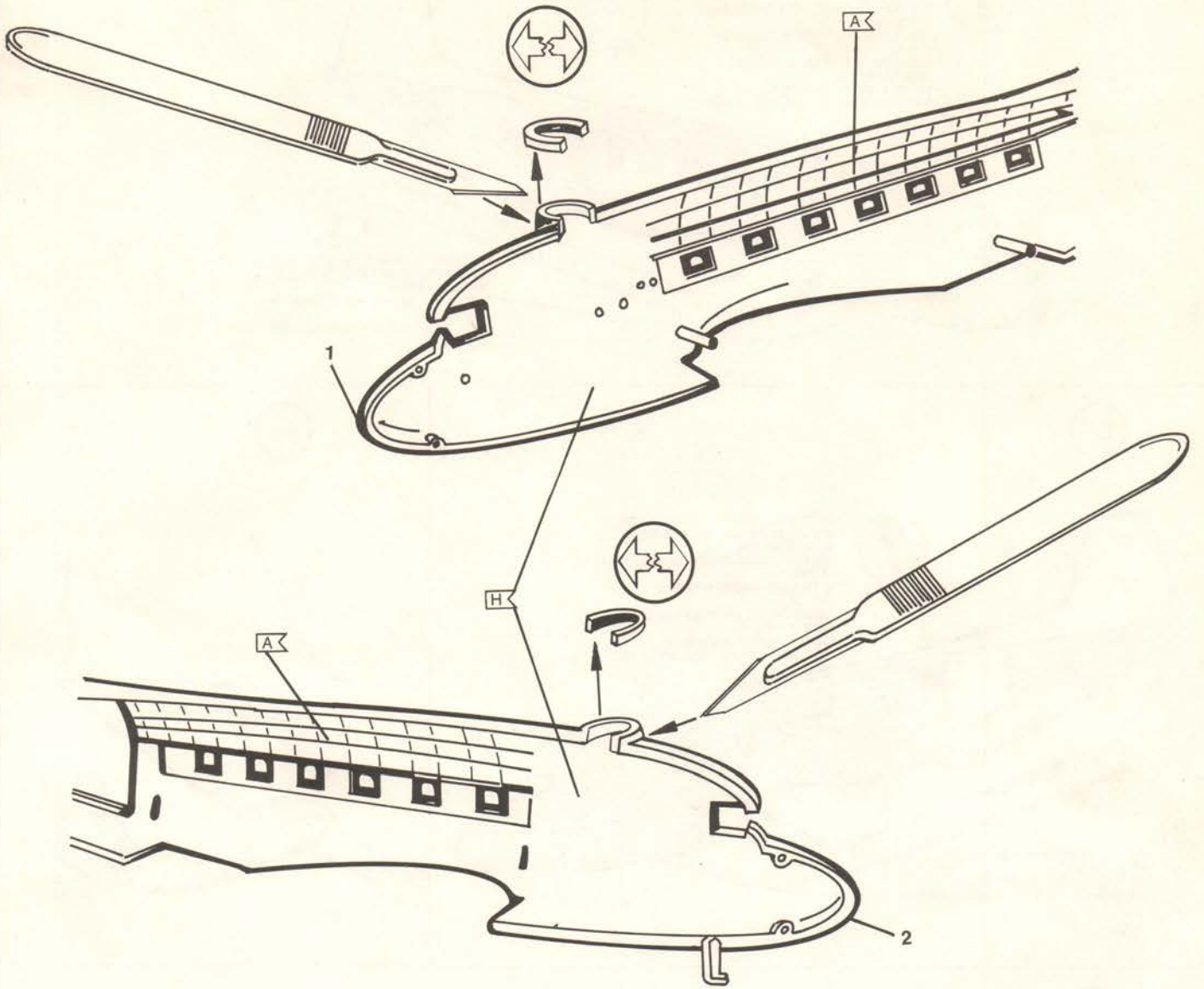

8 

- OPTIONAL: CLEAN OUT HOLES FOR PART 45.
- WAHLWEISE: LÖCHER SIND FÜR TEIL 45 AUSZUSCHNEIDEN.
- OPCIONAL: LIMPIENSE LOS ORIFICIOS PARA LA PIEZA 45.
- NAAR KEUZE: KNIP DE OPENINGEN VOOR DEEL 45.
- FACULTATIF: NET TOYER LES ORIFICES POUR LA PIECE 45.
- VALFRITT: SKÄRUT HÅL FÖR DEL 45.
- FACOLTATIVO: APRIRE I FORI PER LA PARTE 45.

- SEE STEP 34
- SIEHE STUFE 34
- VEASE PASO 34
- ZIE STAP 34
- VOIR ETAPE 34
- SE STEG 34
- VEDERE FASE 34

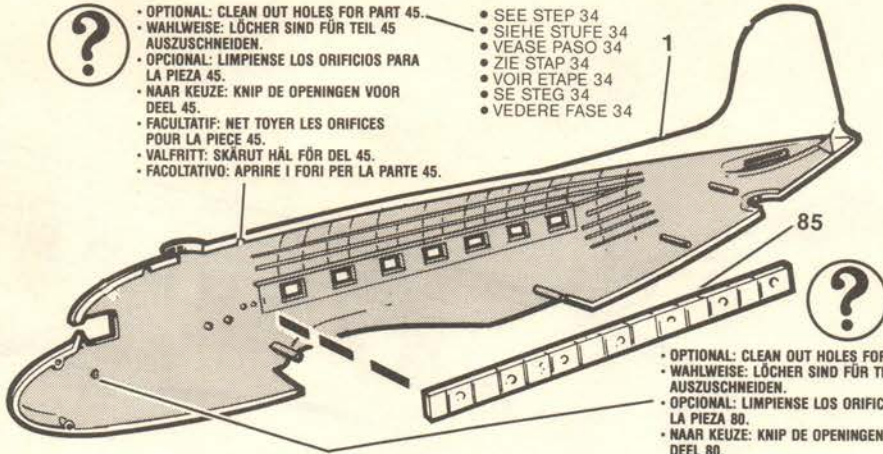

- OPTIONAL: CLEAN OUT HOLES FOR PART 80.
- WAHLWEISE: LÖCHER SIND FÜR TEIL 80 AUSZUSCHNEIDEN.
- OPCIONAL: LIMPIENSE LOS ORIFICIOS PARA LA PIEZA 80.
- NAAR KEUZE: KNIP DE OPENINGEN VOOR DEEL 80.

9 

- OPTIONAL: CLEAN OUT HOLES FOR PART 22.
- WAHLWEISE: LÖCHER SIND FÜR TEIL 22 AUSZUSCHNEIDEN.
- OPCIONAL: LIMPIENSE LOS ORIFICIOS PARA LA PIEZA 22.
- NAAR KEUZE: KNIP DE OPENINGEN VOOR DEEL 22.
- FACULTATIF: NET TOYER LES ORIFICES POUR LA PIECE 22.
- VALFRITT: SKÄRUT HÅL FÖR DEL 22.
- FACOLTATIVO: APRIRE I FORI PER LA PARTE 22.

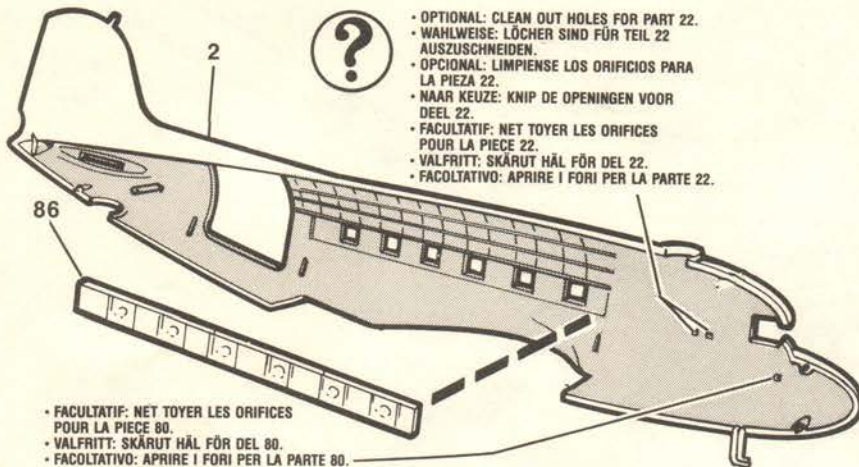

- FACULTATIF: NET TOYER LES ORIFICES POUR LA PIECE 80.
- VALFRITT: SKÄRUT HÅL FÖR DEL 80.
- FACOLTATIVO: APRIRE I FORI PER LA PARTE 80.

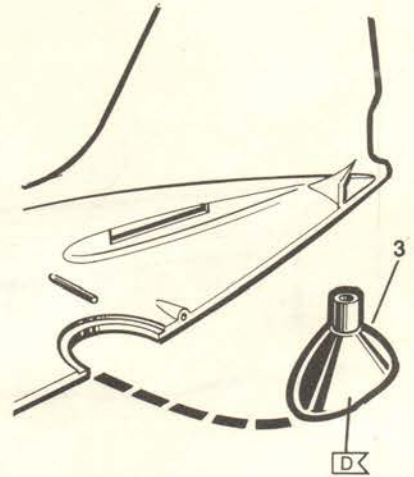
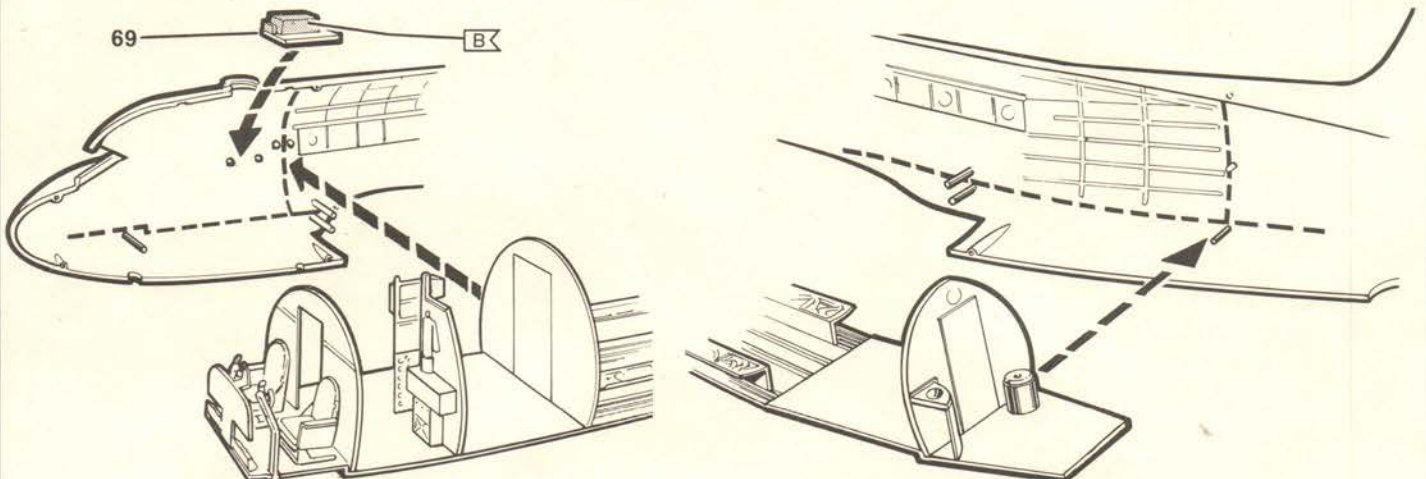
10 11 

12 

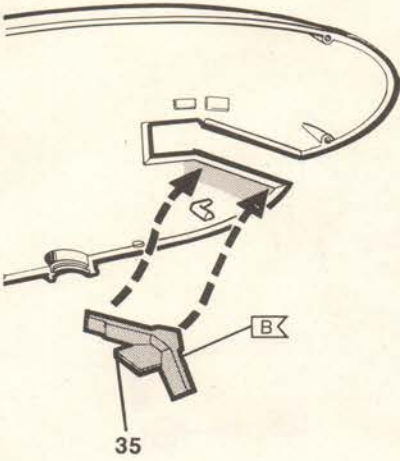

13 

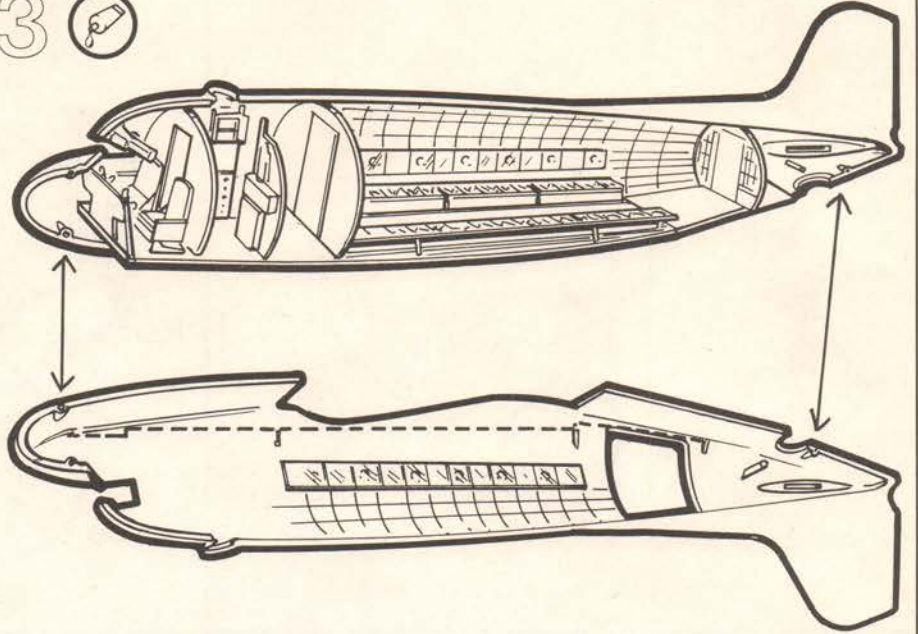

14 

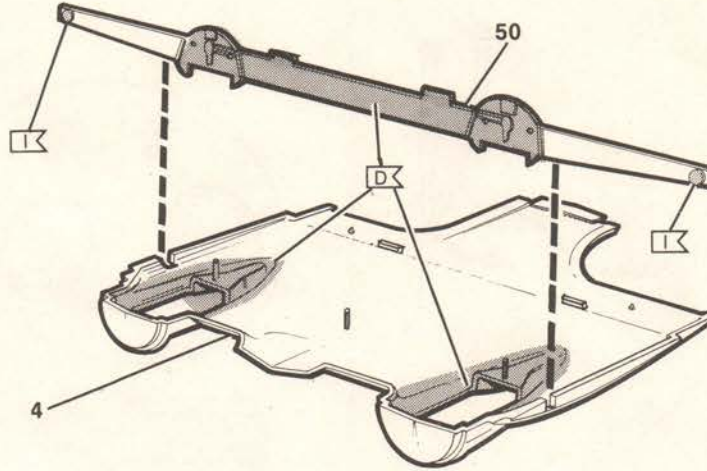

15 

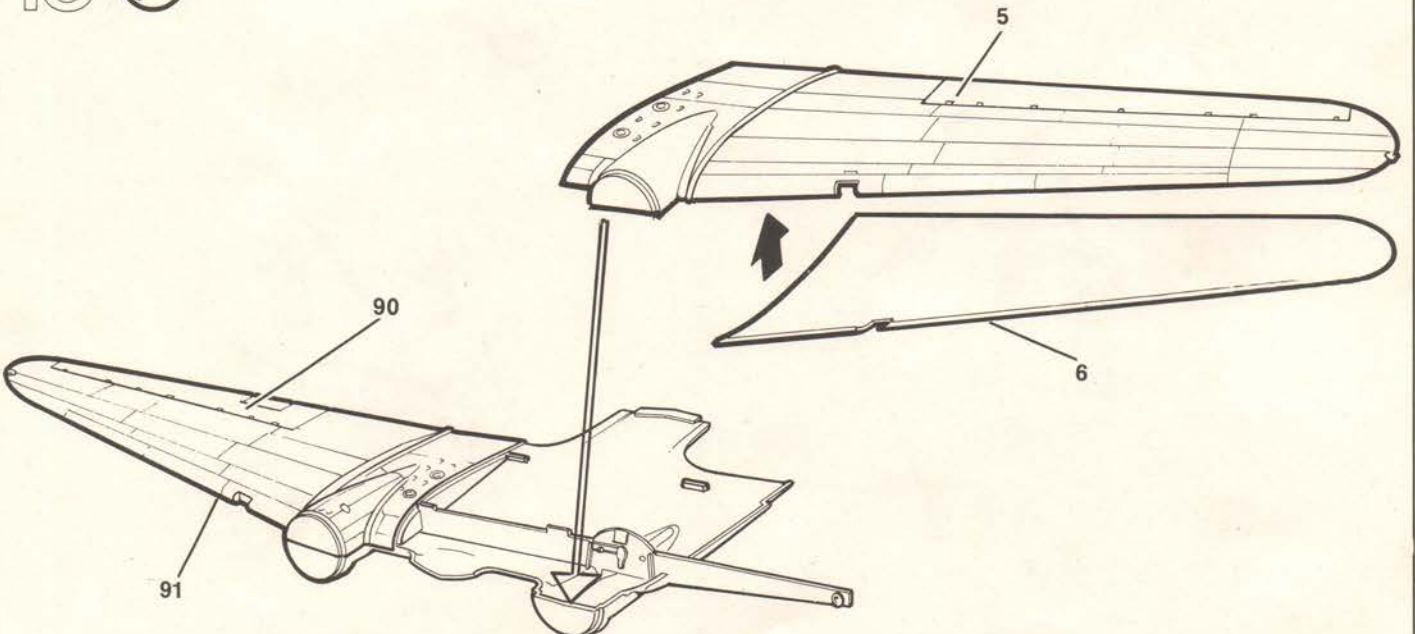

16 

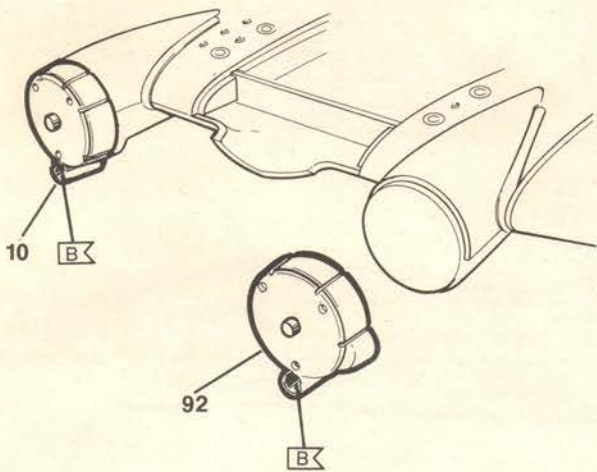

17 

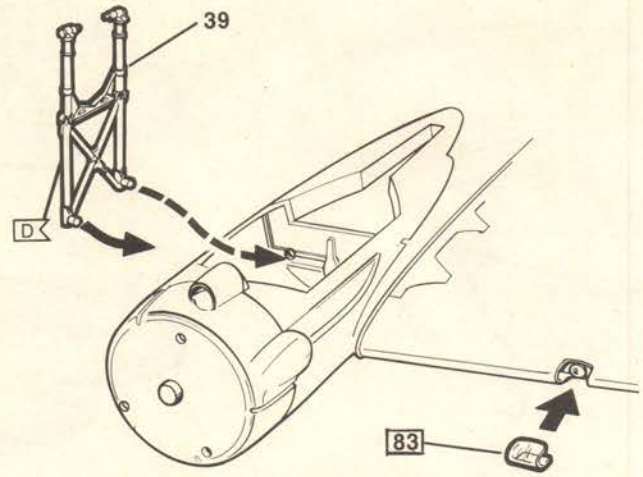

18 

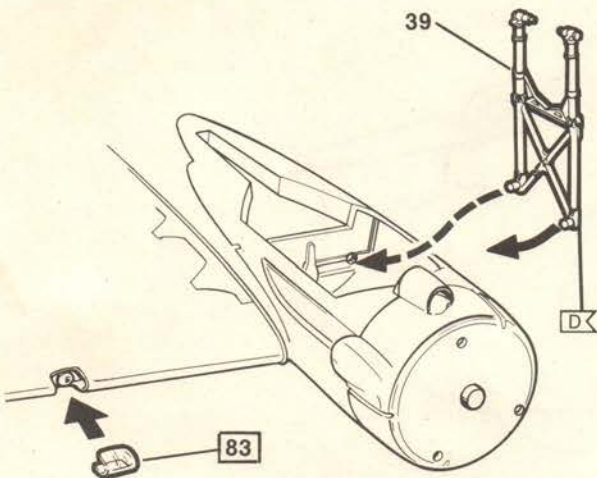

19 

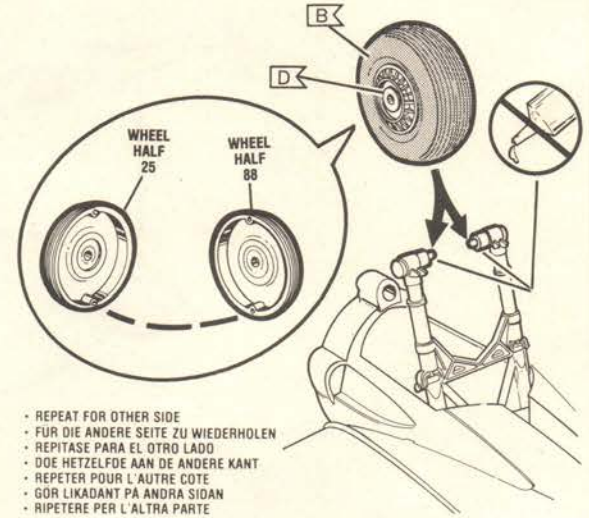

20 

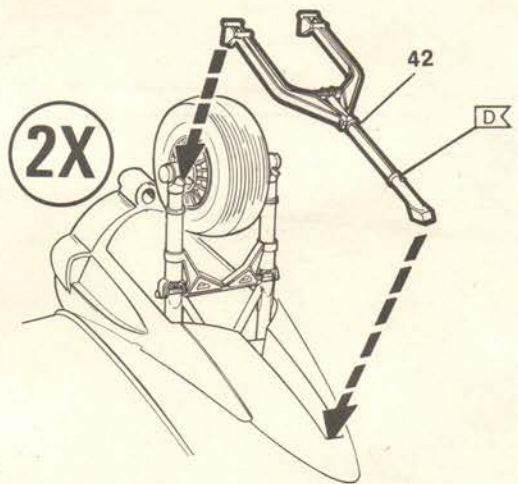

21 

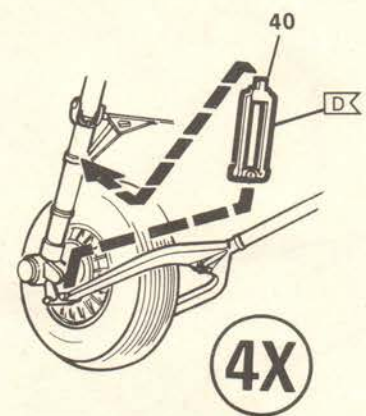

22

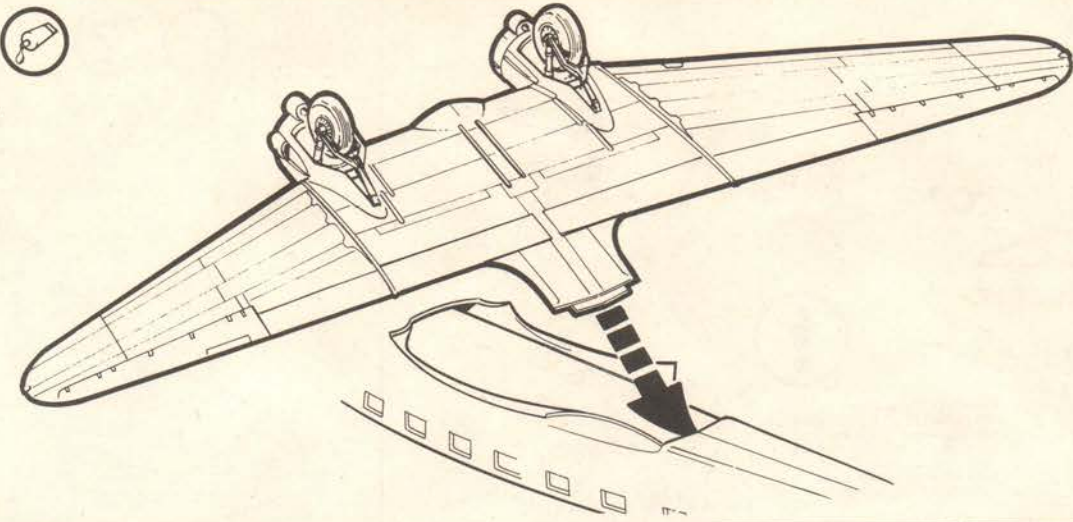

23

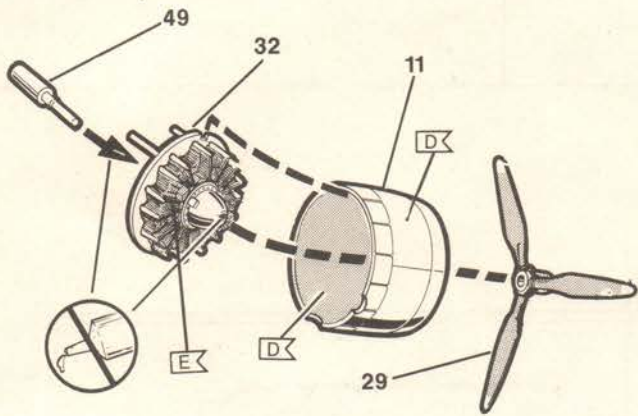

24

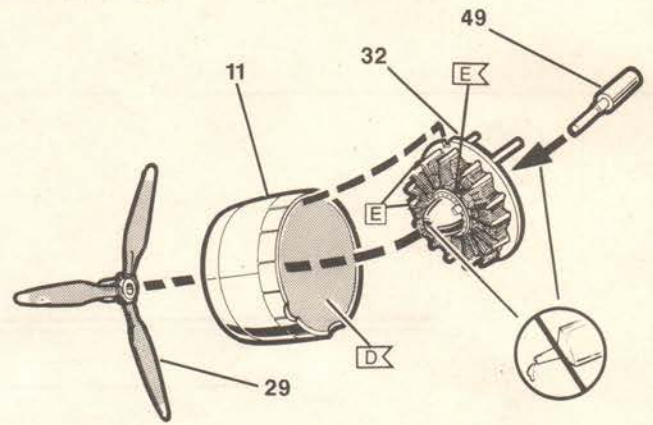

25

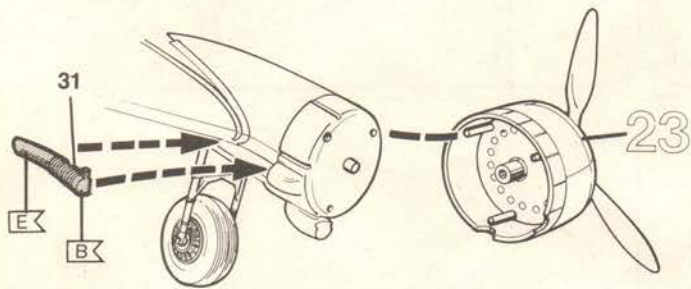

26

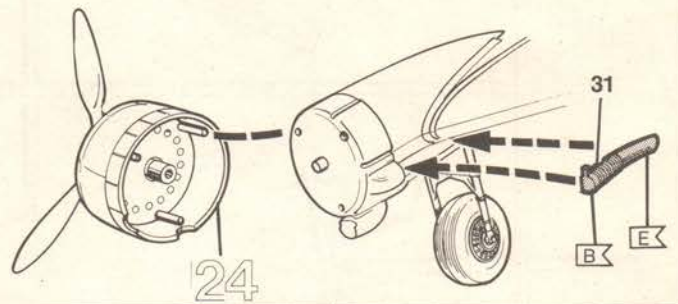

27

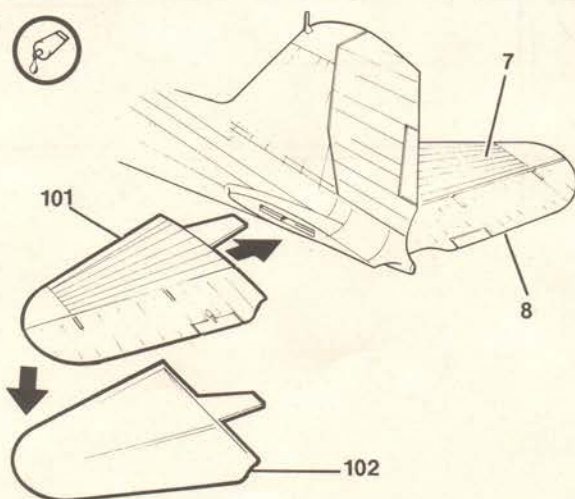

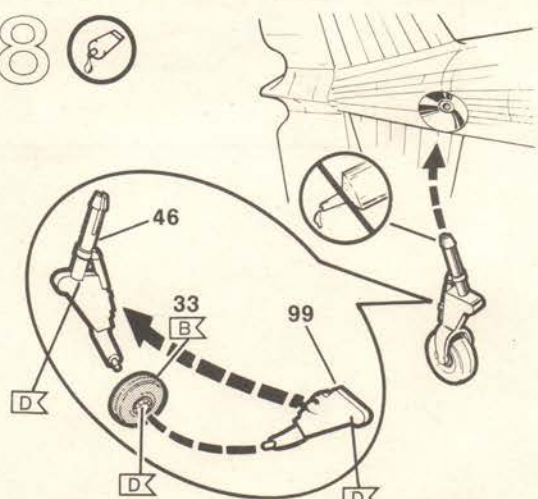

28

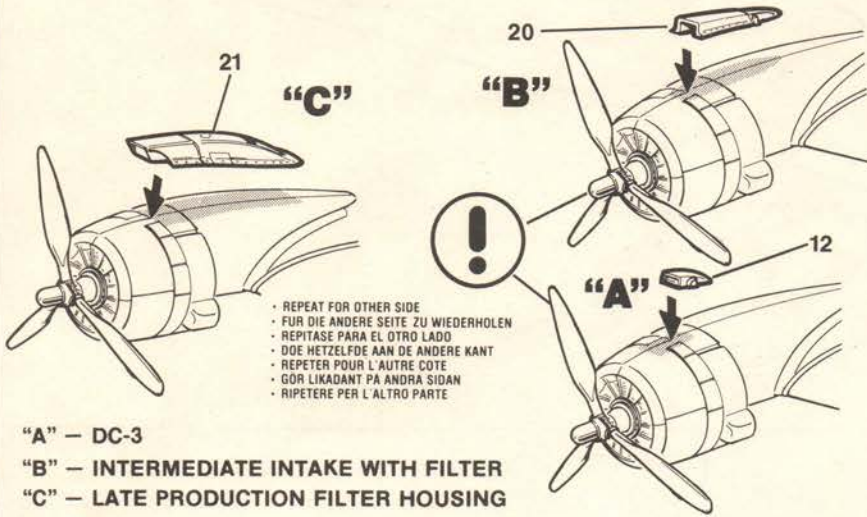

29 



30  

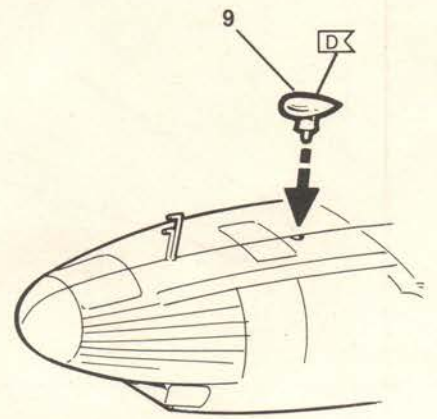

31 

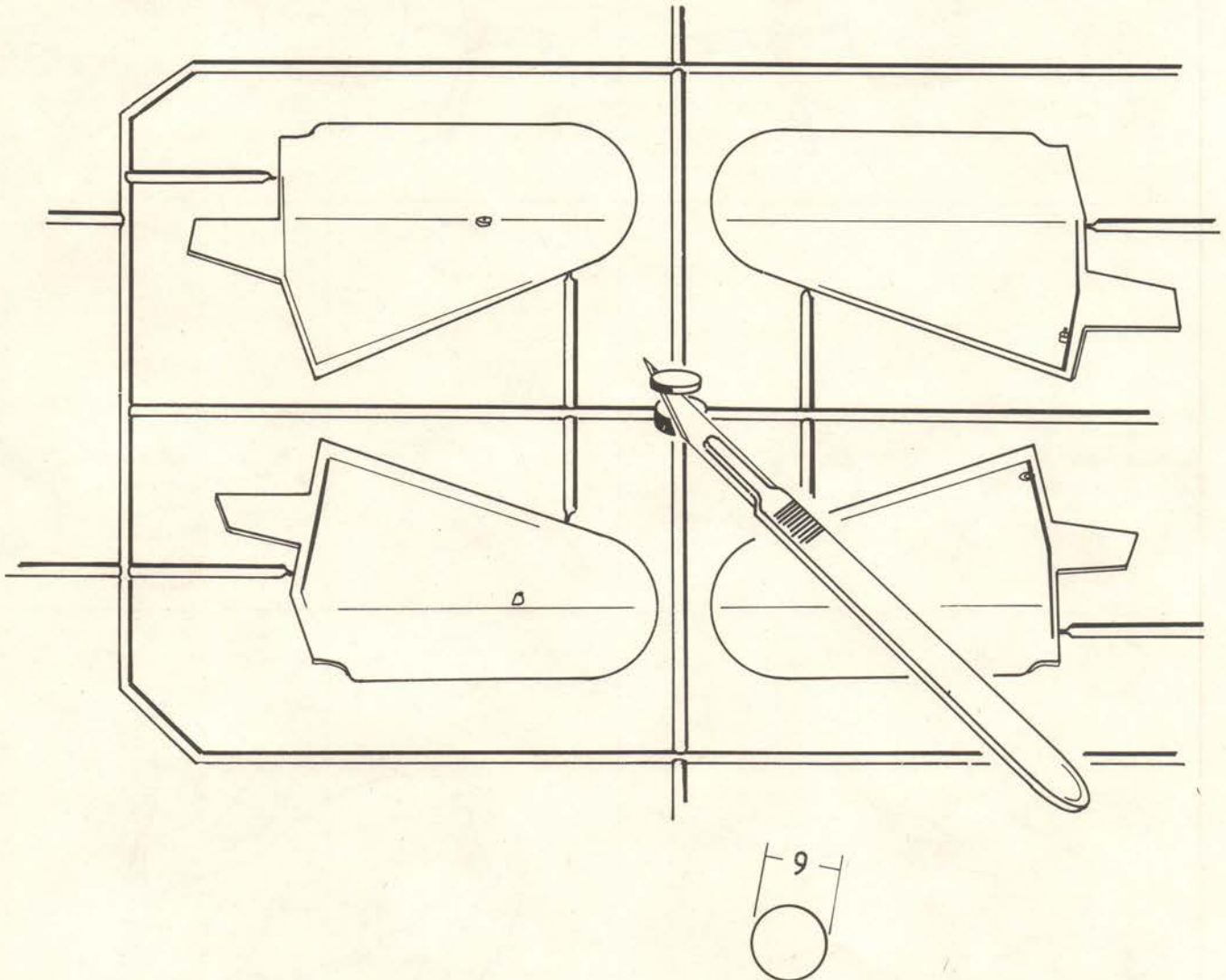



32  

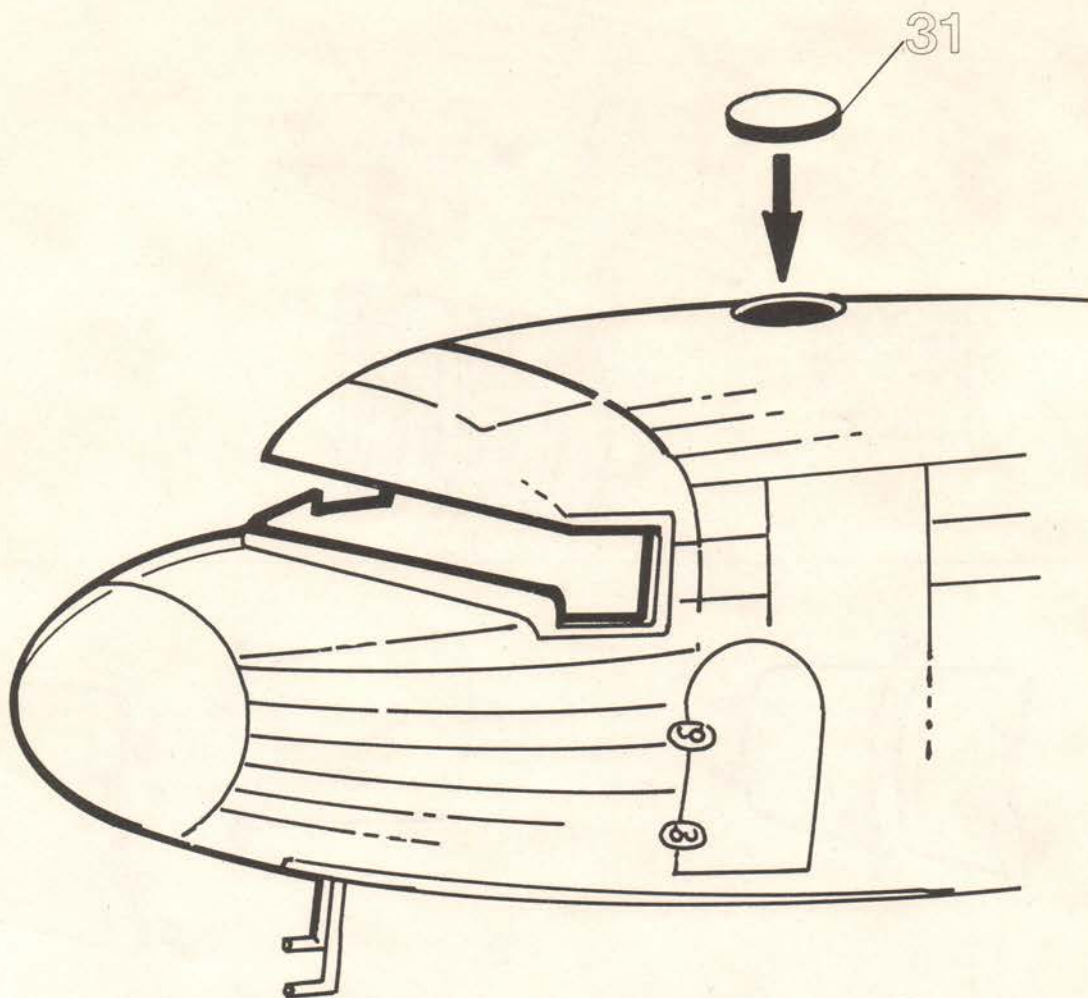

33 

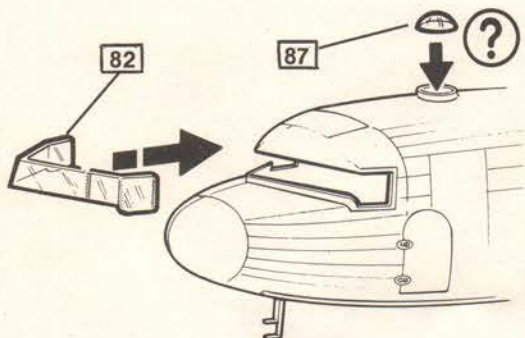

34  

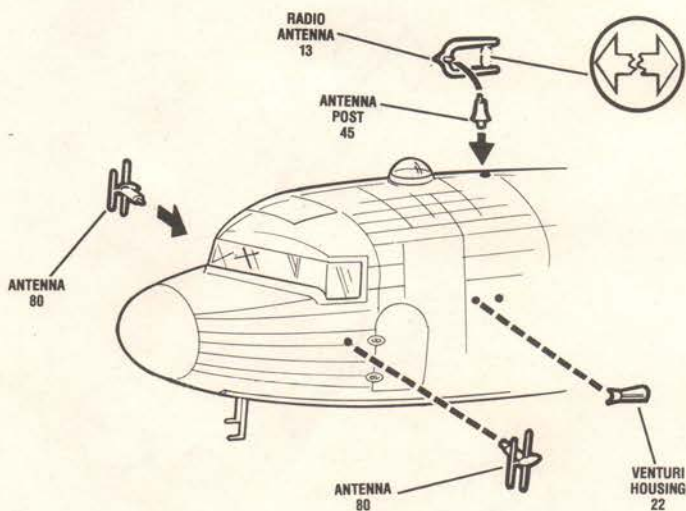

35

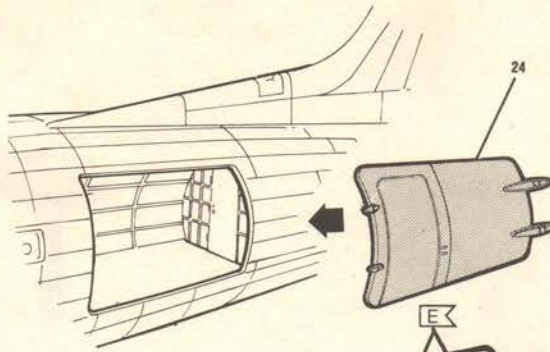

- DOORS CLOSED
- TUEKLAFFEN GESCHLOSSEN
- PUERTAS CERRADAS
- DEUREN GESLOTEN
- PORTES FERMEES
- STANGDA DORRAR
- PORTE CHIUSE

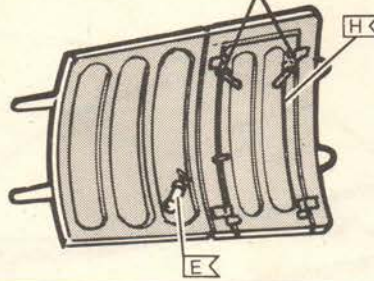

35

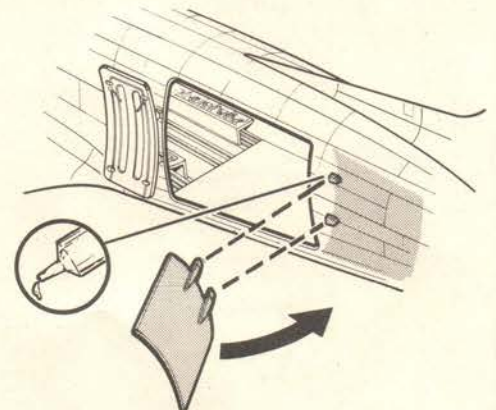
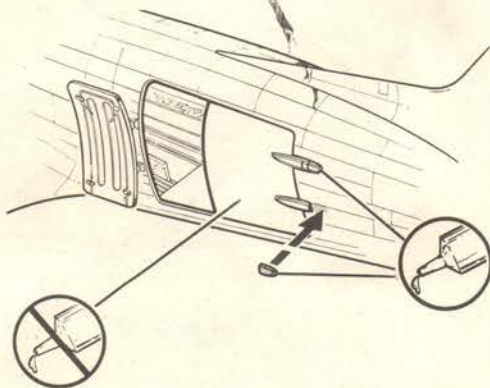
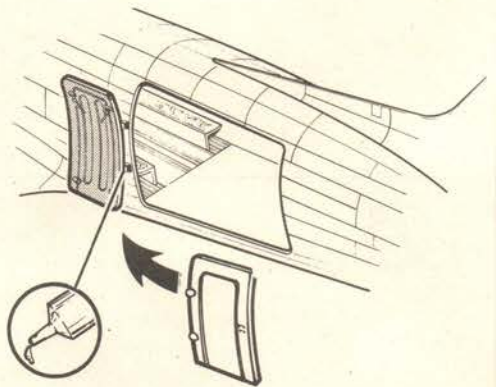
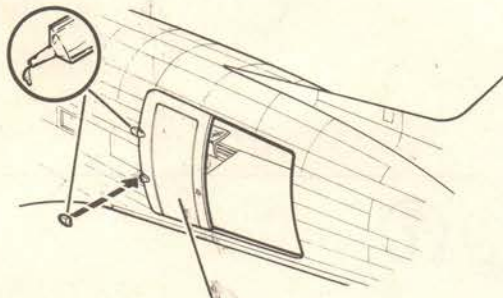
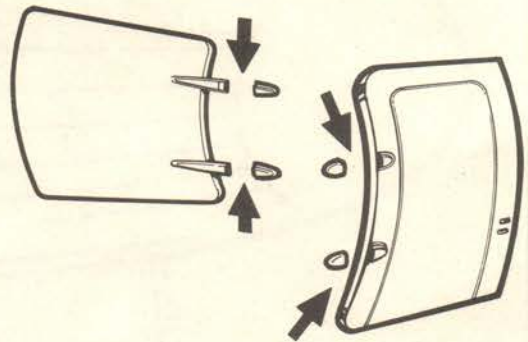
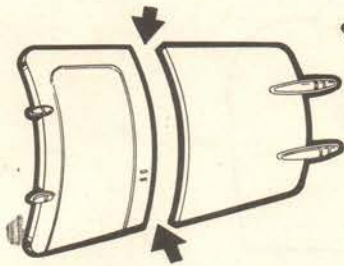

# 36

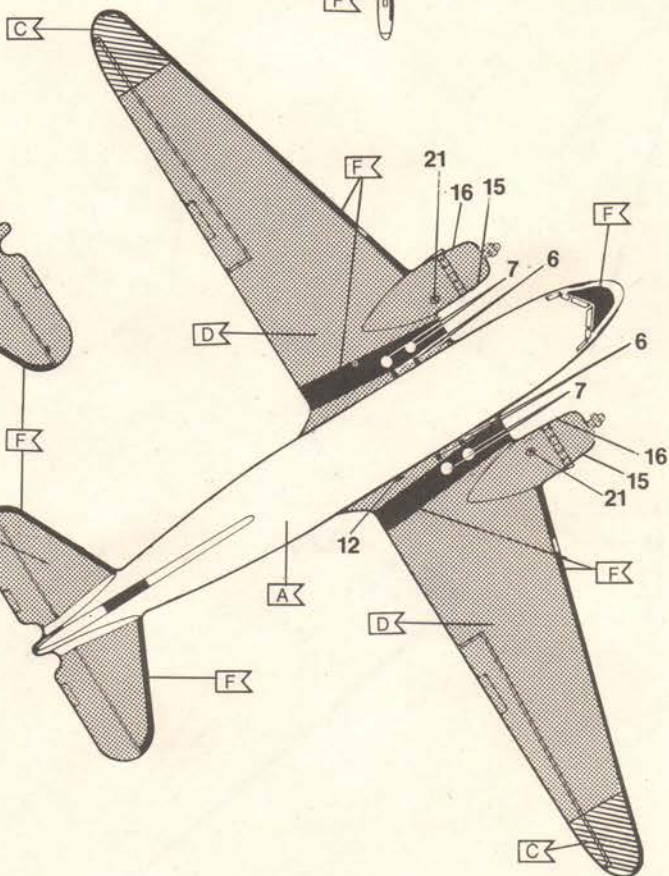
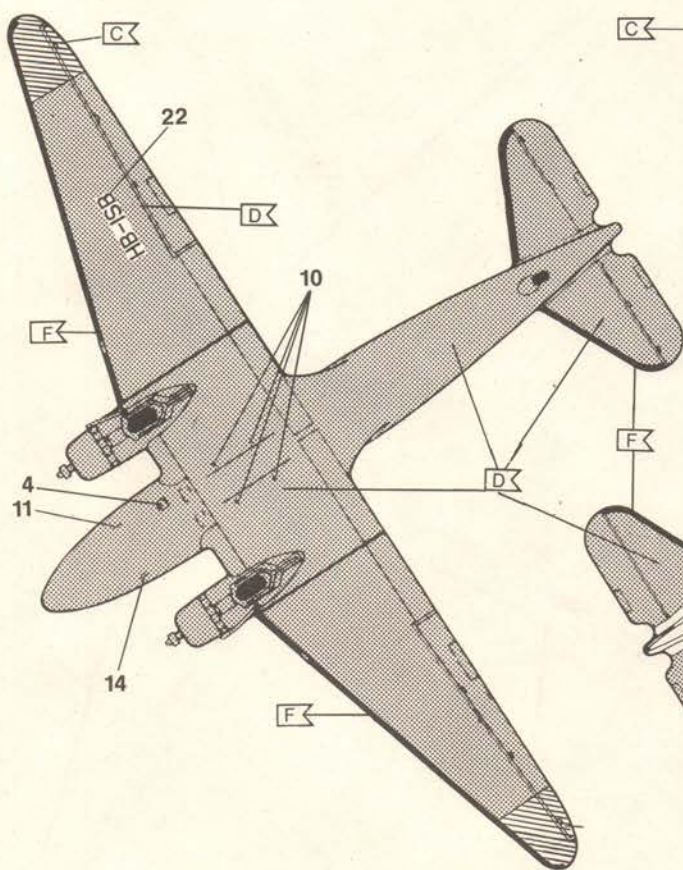
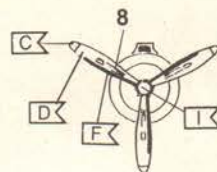
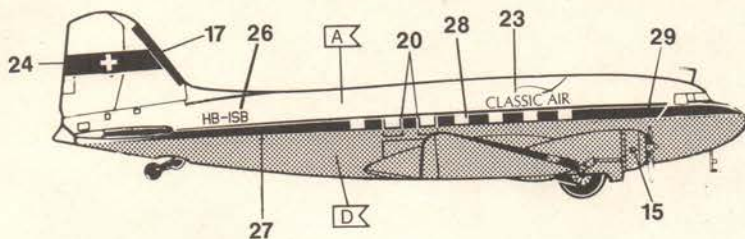
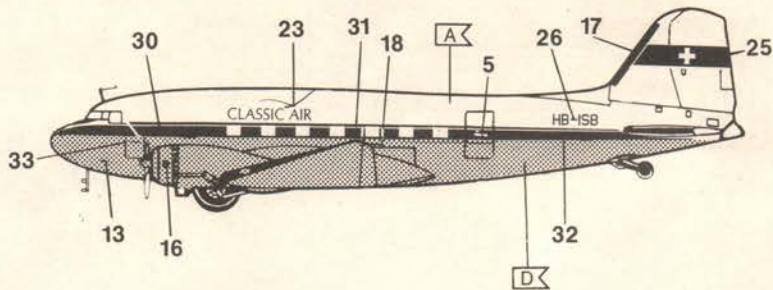

37

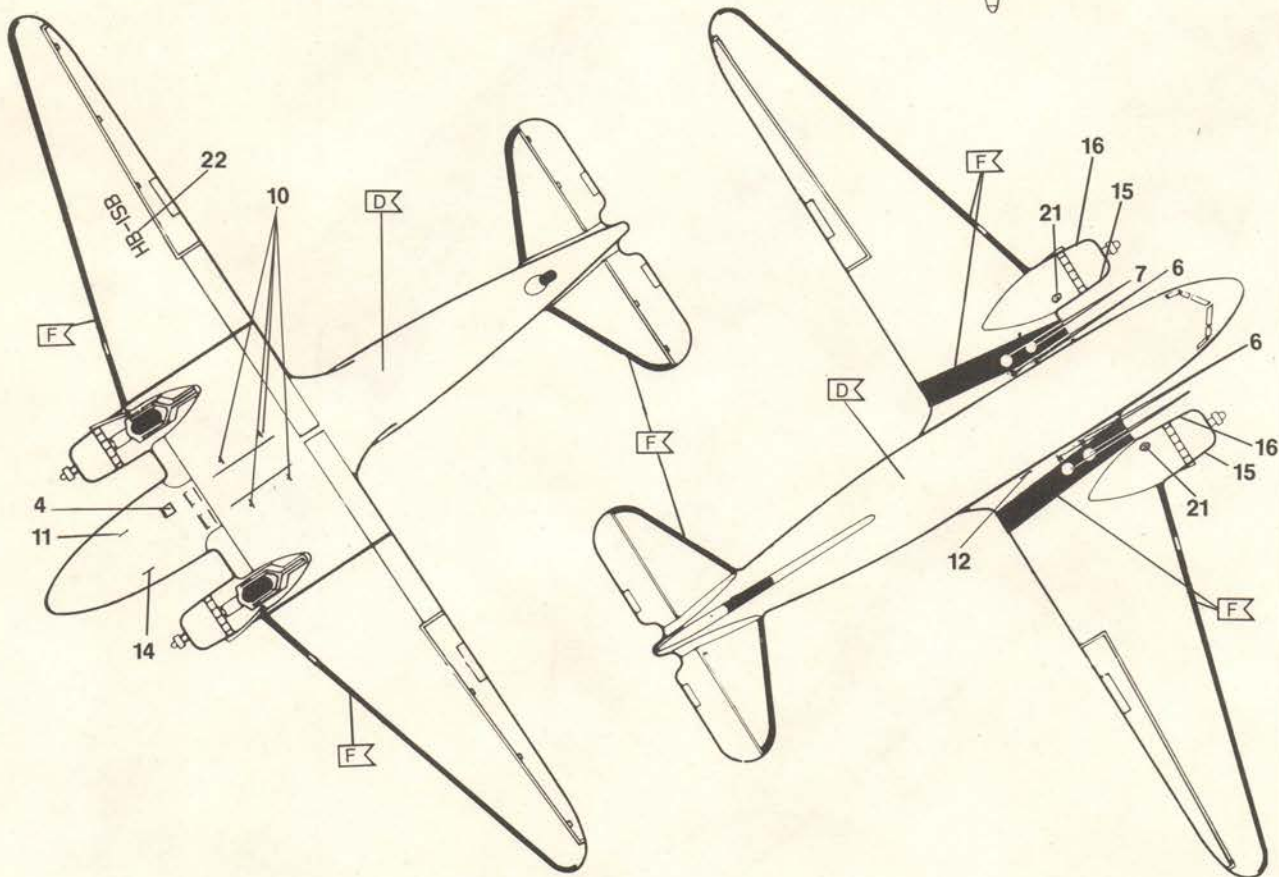
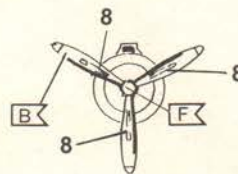
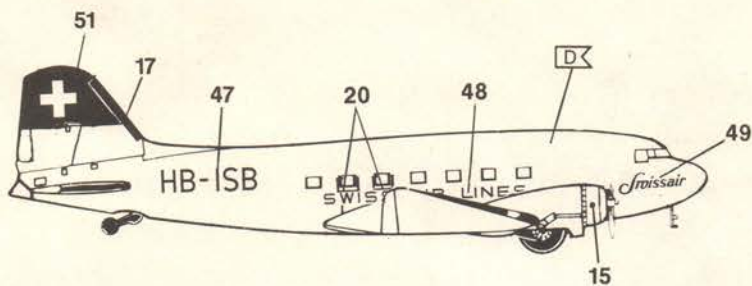
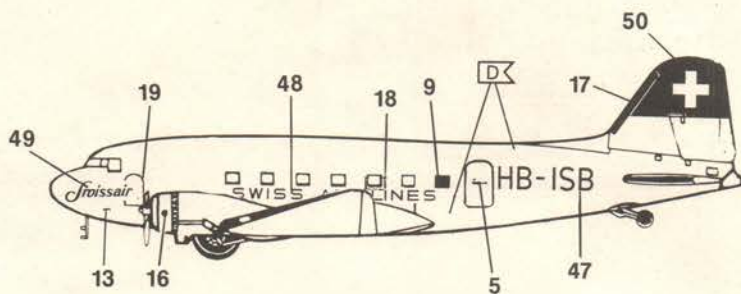

# 38

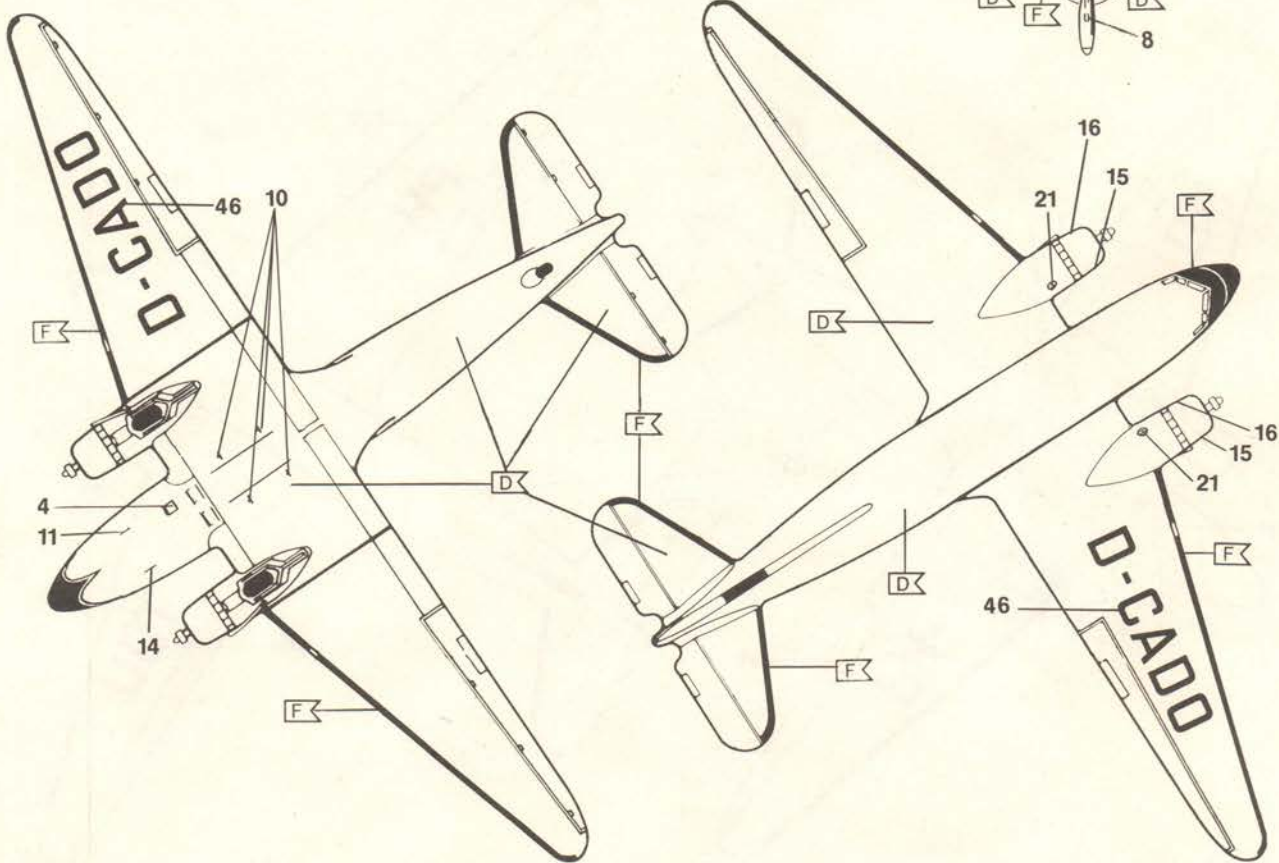
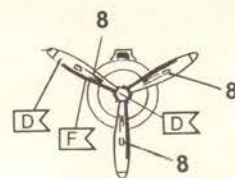
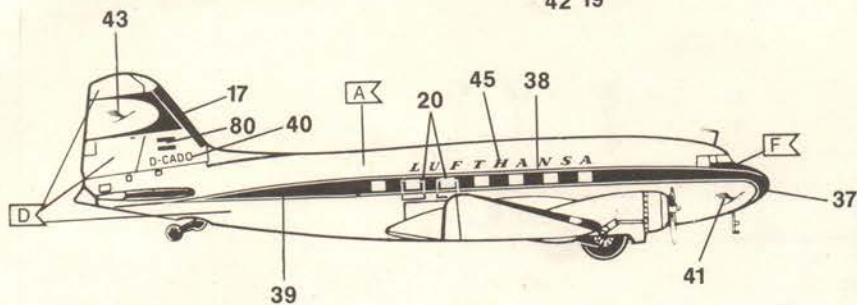
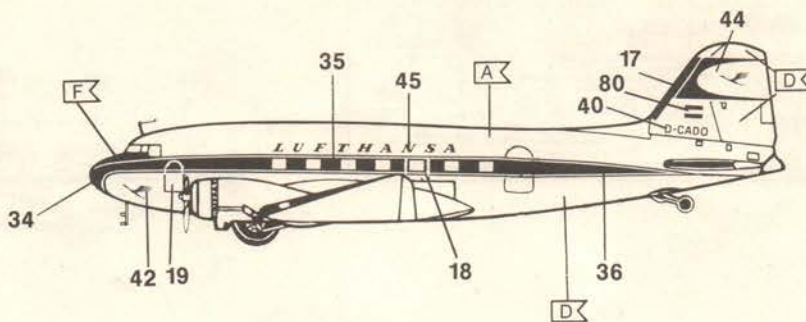

# 39

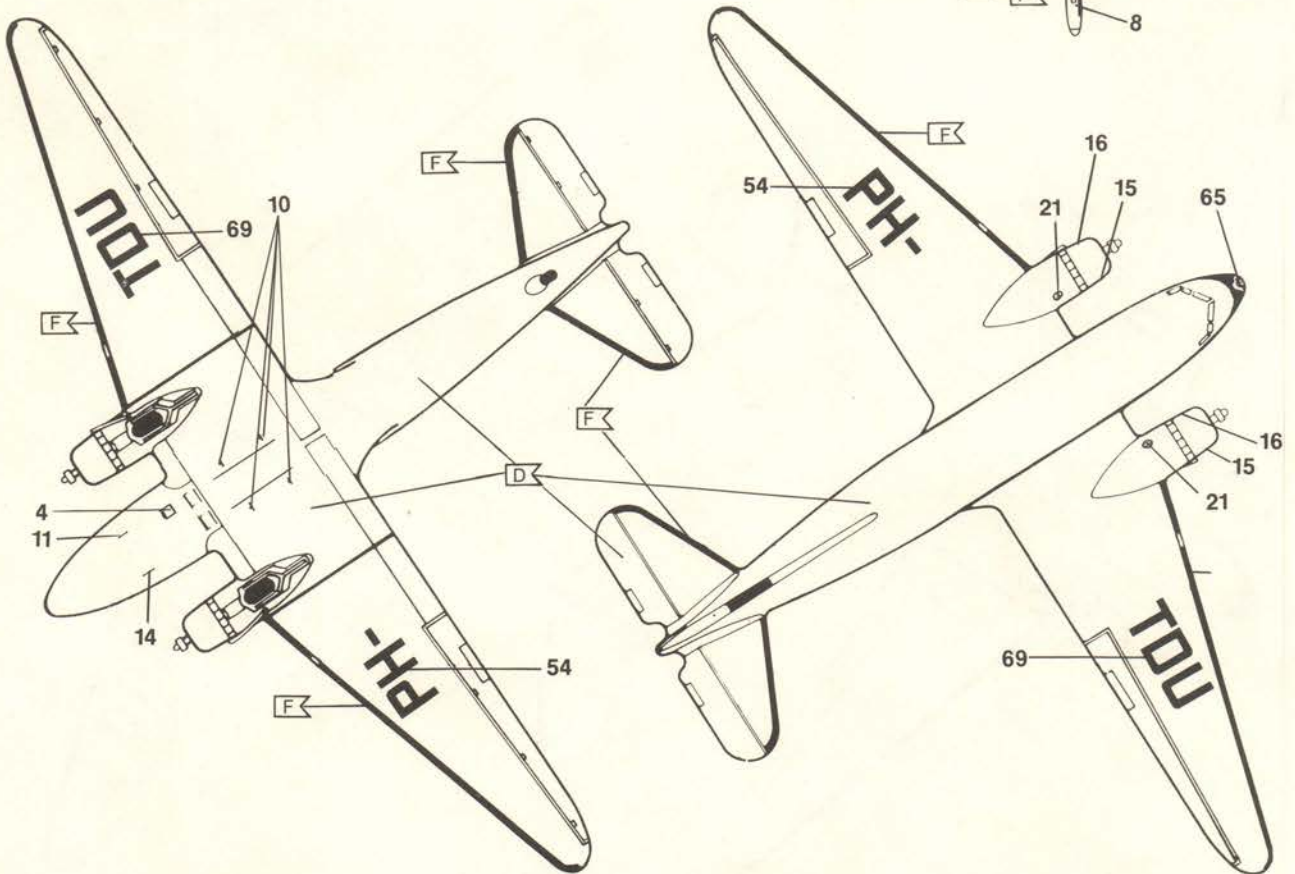
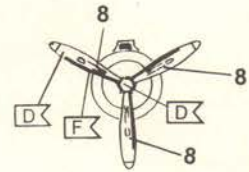
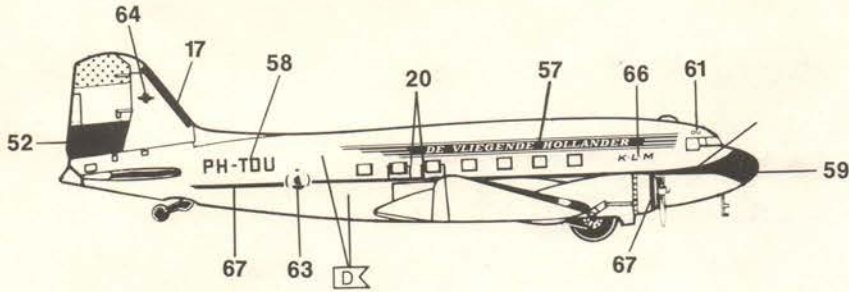
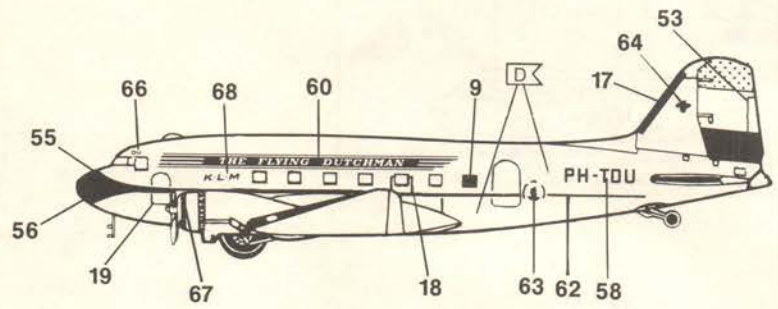

40

