



1/72nd SCALE

2163

**ACADEMY**

HOBBY MODEL KITS

# B-24H LIBERATOR ZODIAC "AQUARIA"

## THE ZODIAC AQUARIA

It appears the idea for the Zodiac Bombers was born in 1943 when the 486th Bomb Group moved to Davis-Monthan Army Air Base in Tucson, Arizona for training. Capt. W. D. Howell, commander of the 834th Bomb Squadron, saw some of the murals and nose art that Cpl. Phillip S. Brinkman had created while assigned to that base. In the six years before WWII, Mr. Brinkman had been employed in Chicago as an illustrator for an advertising agency.

Exactly who decided to use the signs of the Zodiac remains a mystery today, but it was arranged that Cpl. Brinkman would be transferred to the 834th where he could paint the squadron's twelve B-24H Liberators with the 12 signs of the Zodiac.

In April 1944, the 486th arrived at Sudbury, Sussex, England where Sgt. Brinkman started painting the squadron's aircraft with some of the most beautiful and striking nose art ever encountered on an airplane. Twelve designs were made, but only eleven were ever completed. It seems Sgt. Brinkman started TAURUS three times, but each time the aircraft would depart and not return, probably due to being transferred to another squadron. While on duty with the 834th, none of the B-24H aircraft were lost in action on their 49 missions.

AQUARIA, with serial number 42-52545 and code letters 2S-M as commanded by Capt. Jensen.



**8 MAIN FUSELAGE ASSEMBLY**

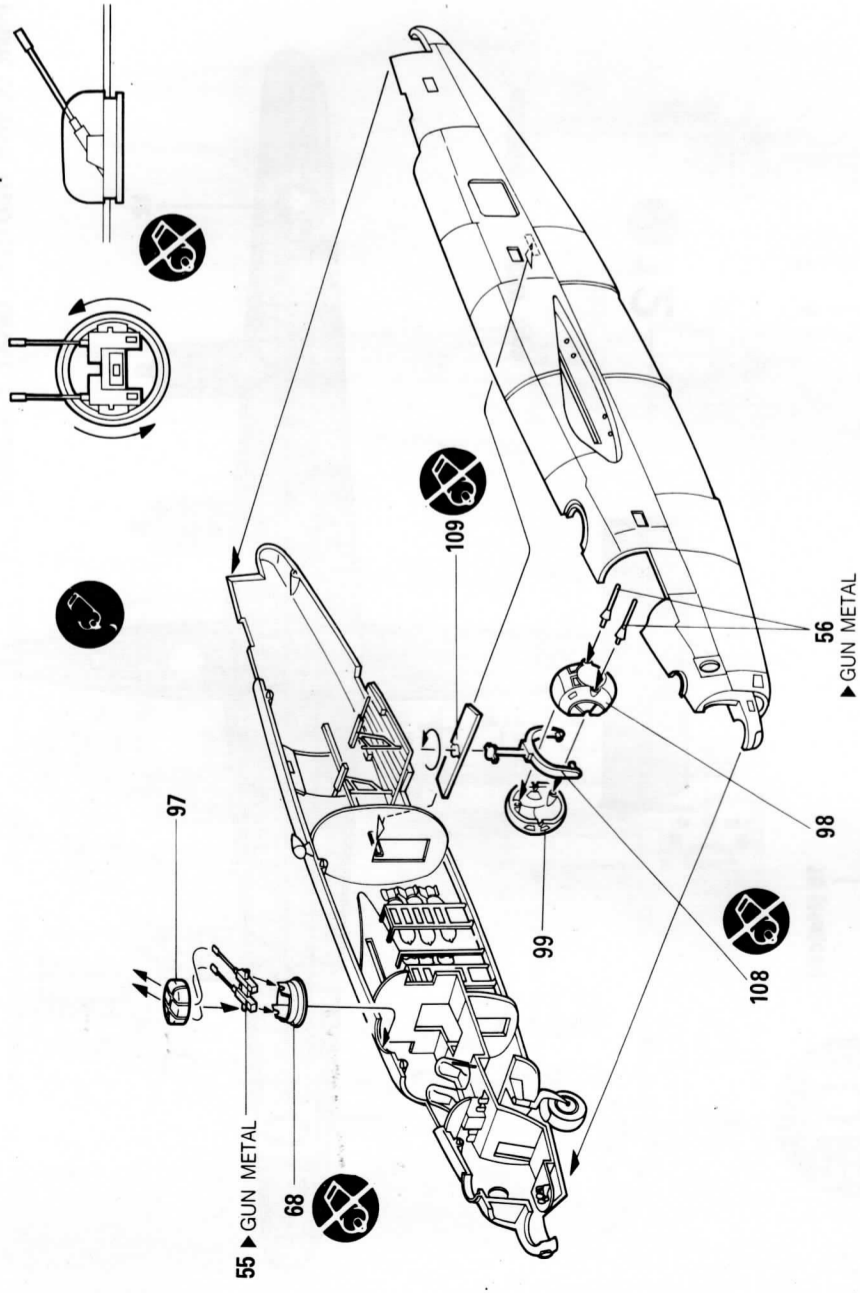

**9 FORWARD FUSELAGE ASSEMBLY**

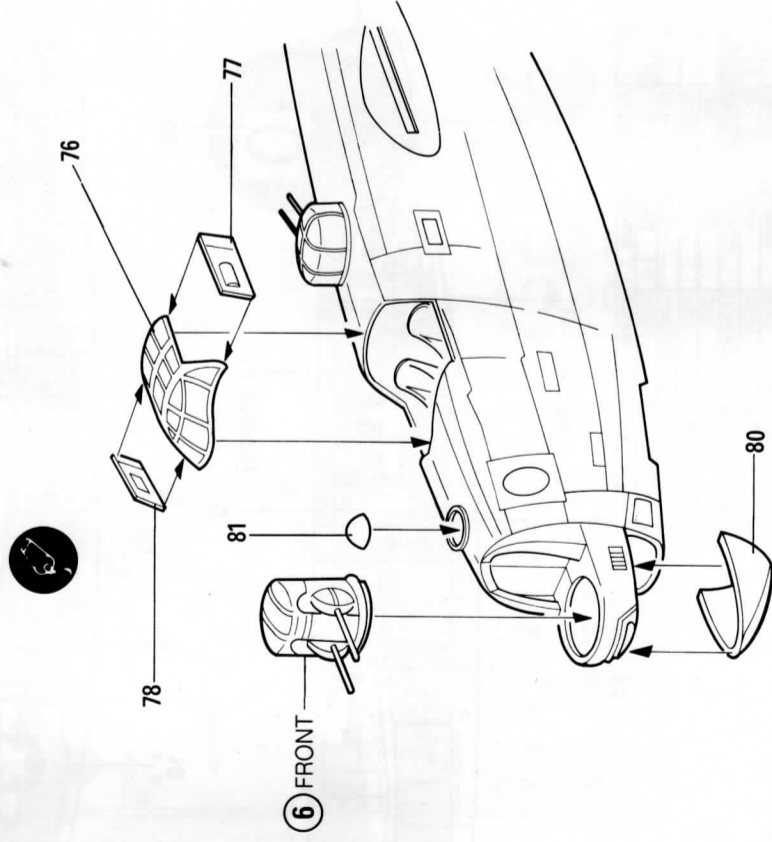

**10 BOMB BAY DOORS**

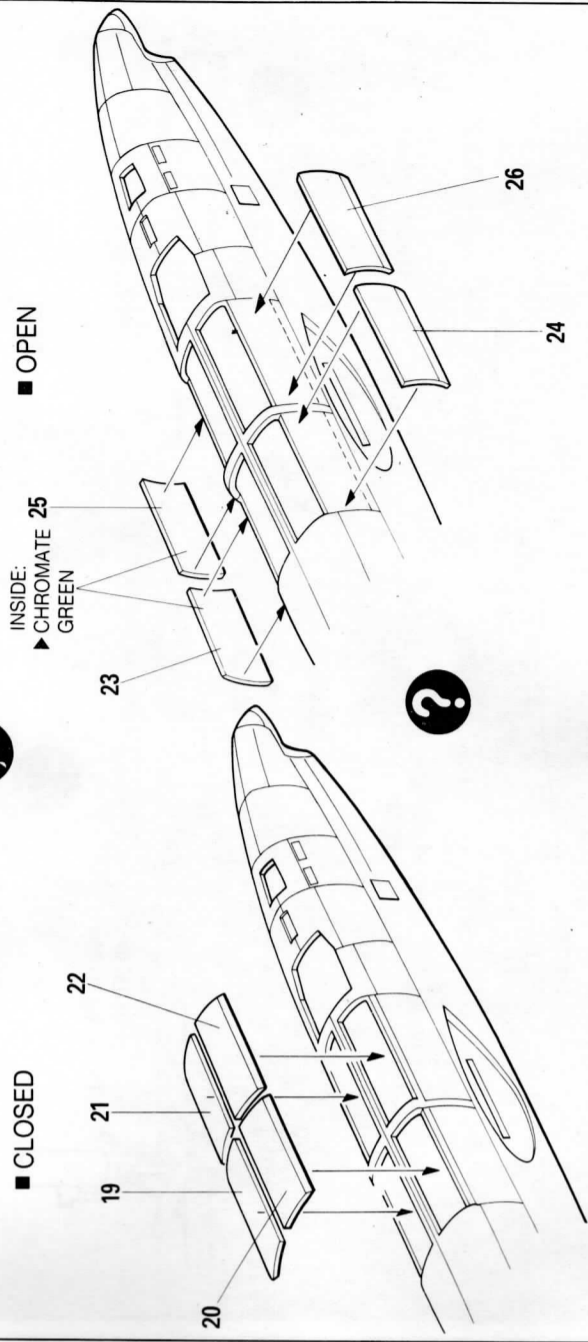

**11 LOWER PANEL, LOWER REAR FUSELAGE**

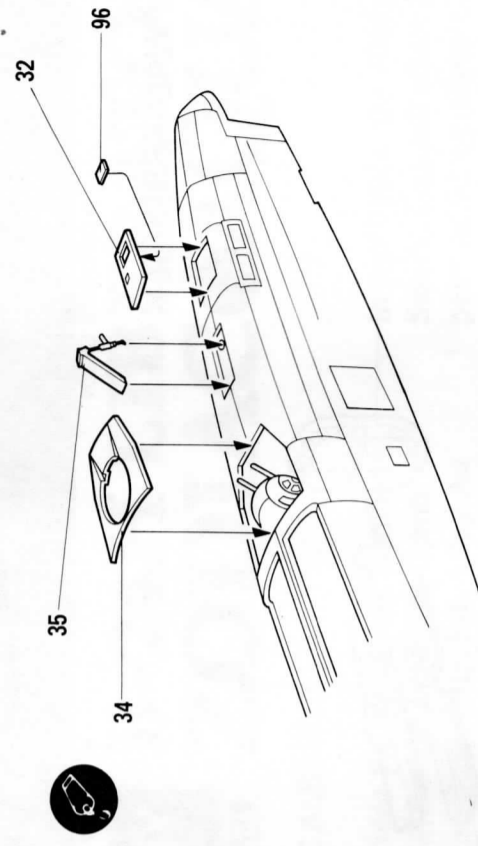

**12 REAR TURRET INSTALLATION**

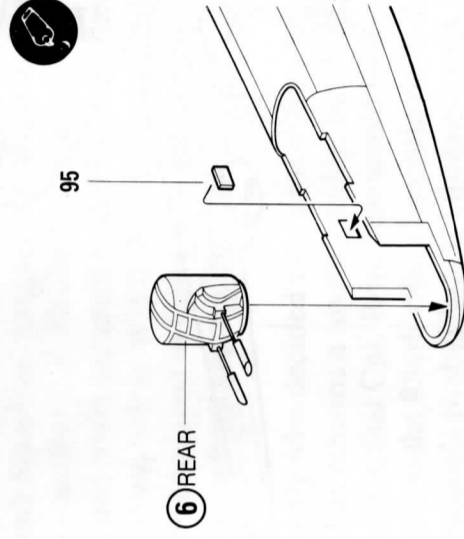

**13 ENGINE ASSEMBLY**

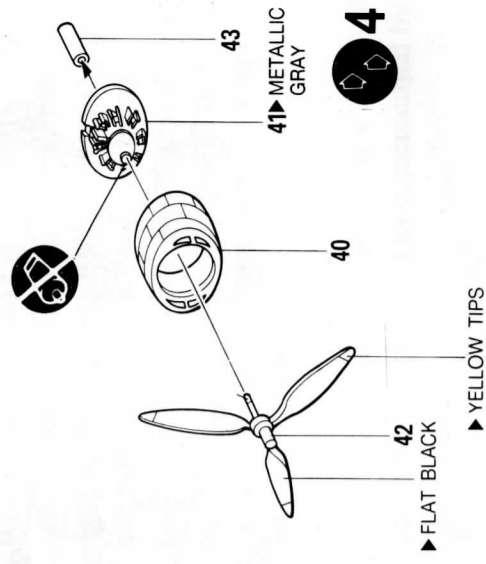

# Painting and Decal Placement Diagram B-24H "Aquaria"

Paint top OLIVE DRAB F.S.34087  
 Paint bottom NEUTRAL GRAY F.S.36173

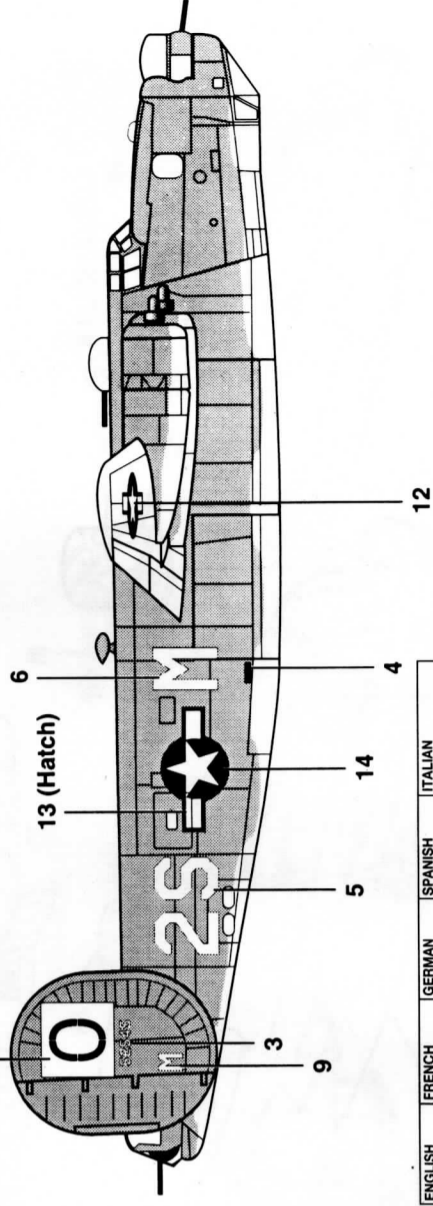
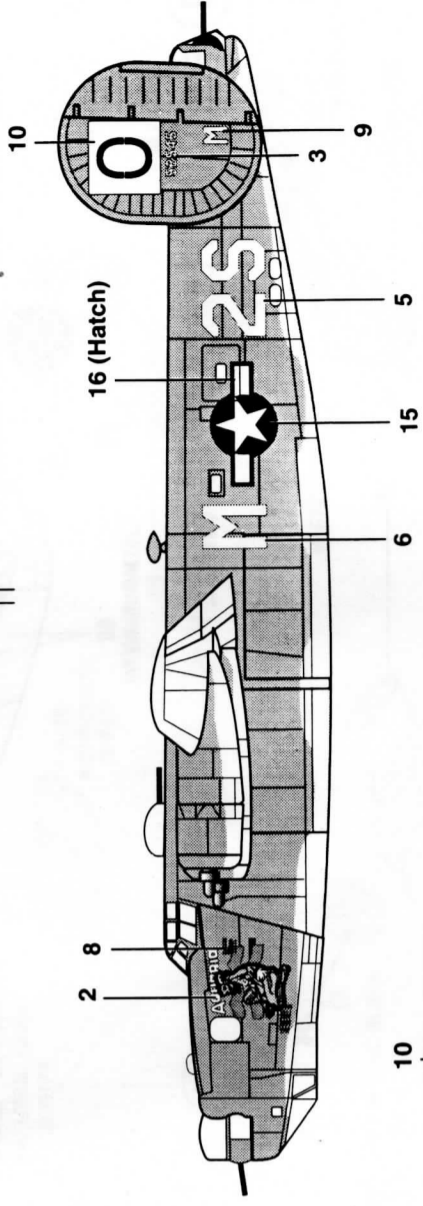
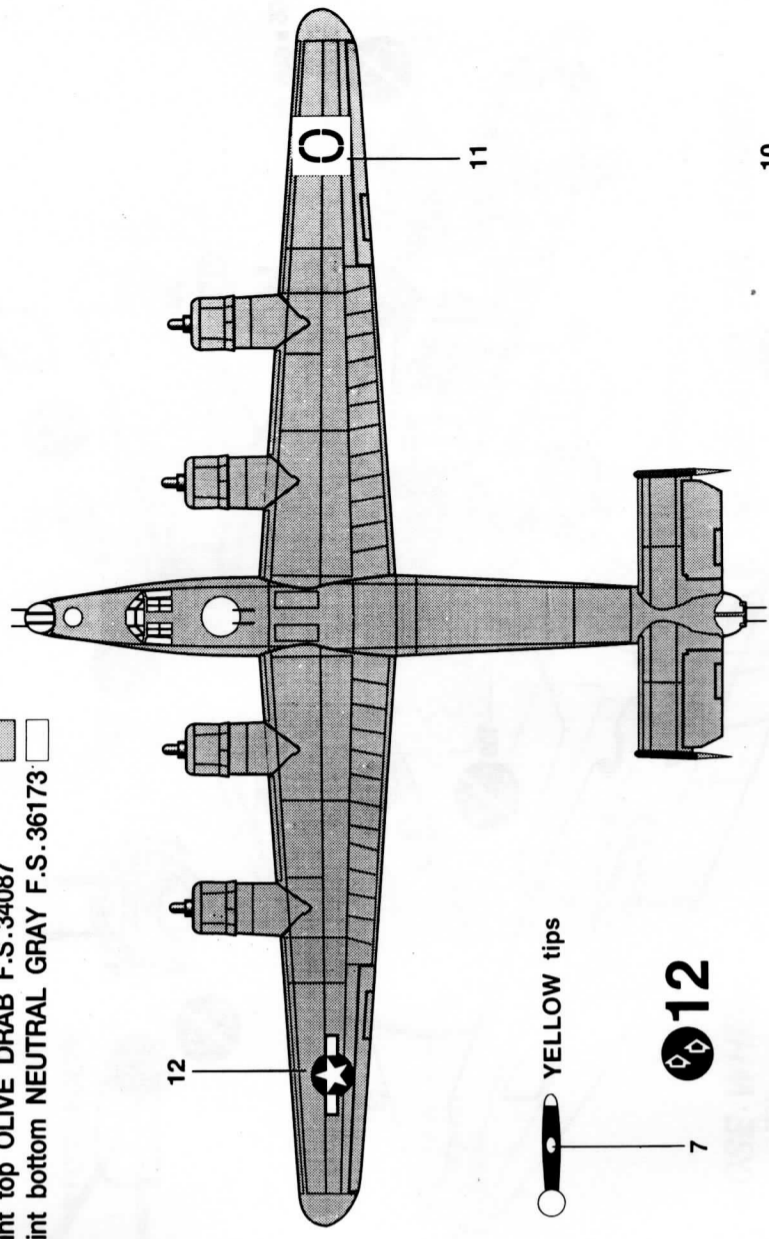

ENGLISH	FRENCH	GERMAN	SPANISH	ITALIAN
WHITE	BIANCO	WEISS	BLANCO	BIANCO
YELLOW	JAUNE	GELB	AMARILLO	GIALLO
RED	ROUGE	ROT	ROJO	ROSSO
GRAY	GRIS	GRAU	GRIS	GRIGIO
GUNMETAL	METALLIC	METALLIC	METALLICO	METALLICO
GREEN	VERT	GRÜN	VERDE	VERDE
SILVER	ARGENT	SILBERN	PLATA	ARGENTO
BLACK	NOIR	SCHWARZ	NEGRO	NERO
FLAT	TERNE	GLANZLOS	APAGADO	OPACO
TAN	BRUN CLAIR	GELBBRAUN	CANELA	MARRONE CHIARO

## 14 WING ASSEMBLY

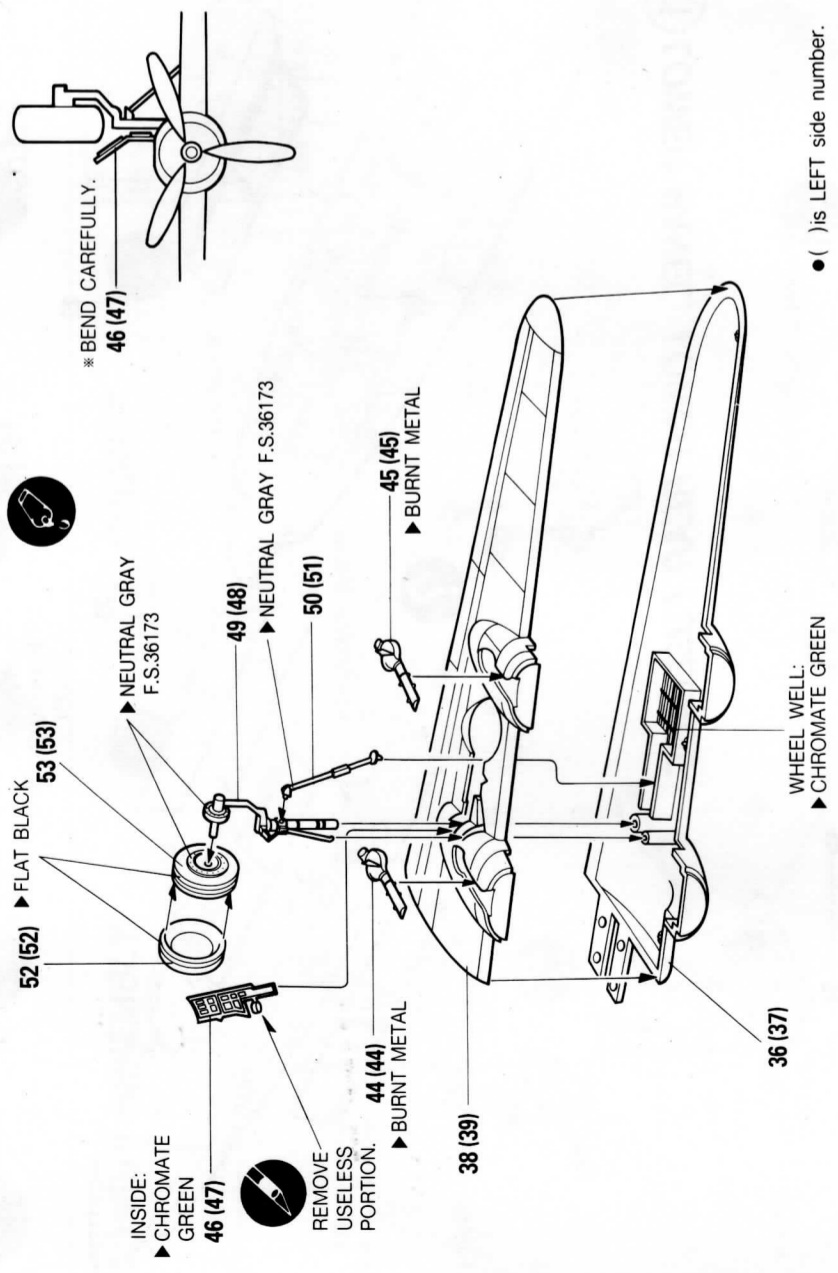

## 15 TAIL AND FINAL ASSEMBLY

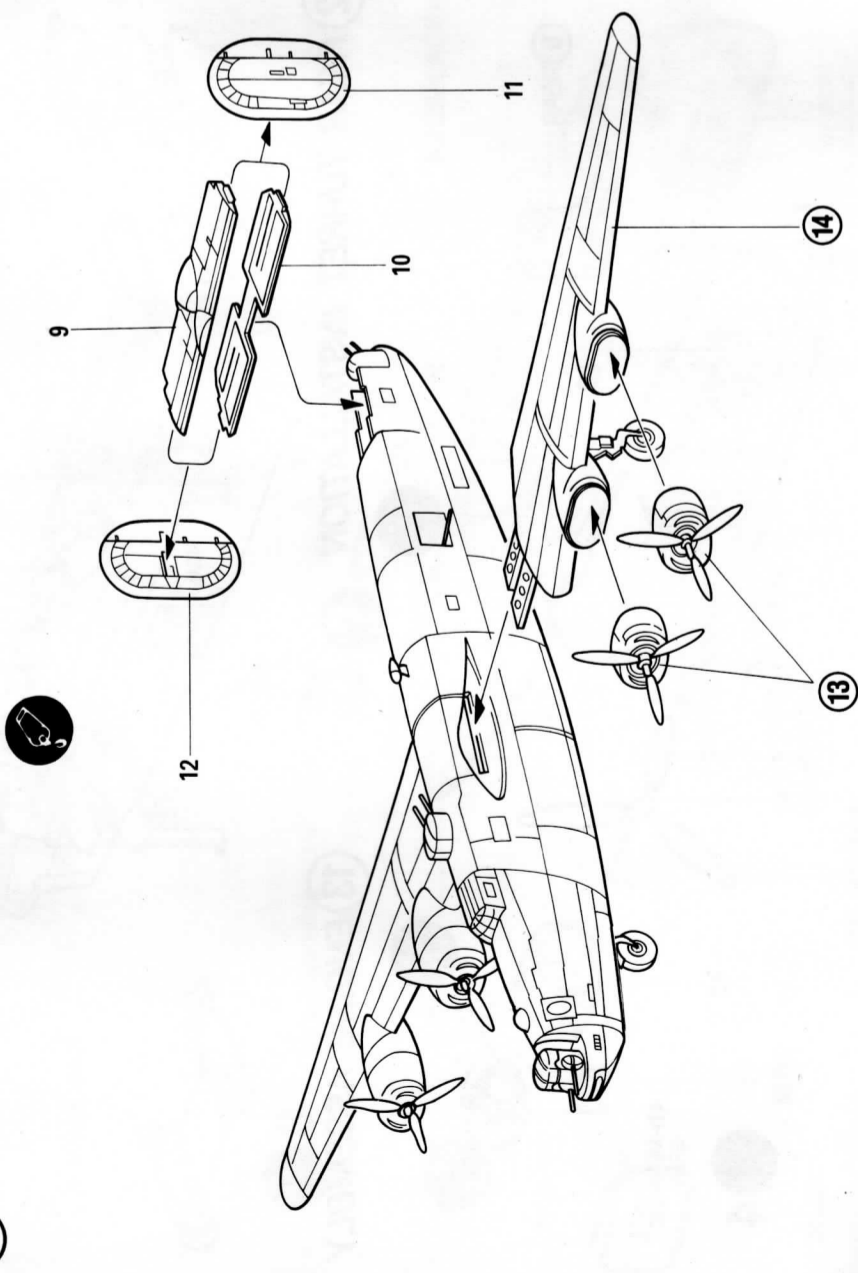

# Parts Locating Diagram

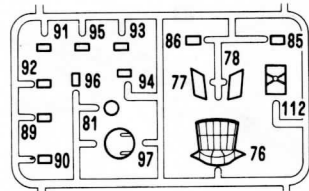
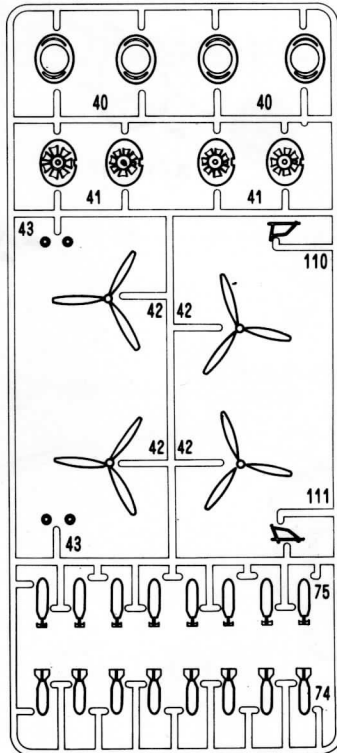
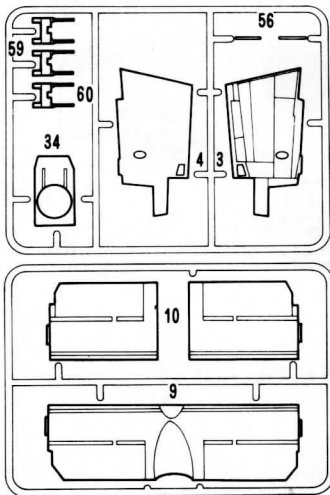
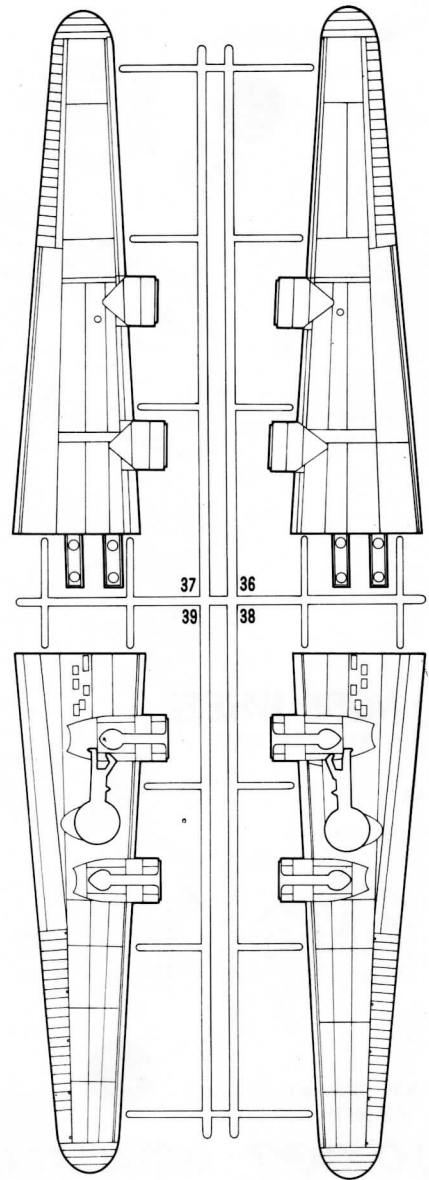
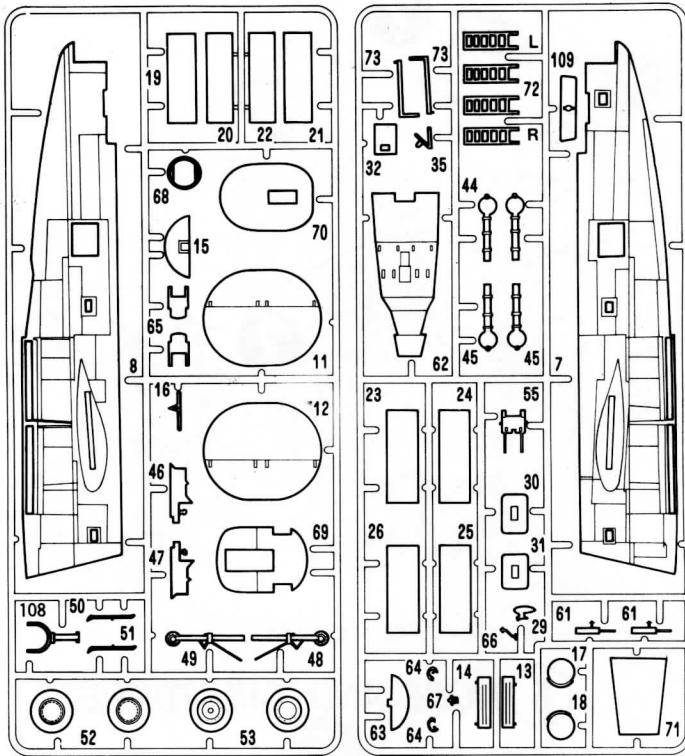

※ UNUSED PARTS:  
59 x 1EA. 85, 86, 90,  
104, 105, 112

**Academy Plastic Model Co., Ltd.**  
273-64, Suyu-dong, Kangbuk-ku, Seoul, Korea  
FAX: 82-2-997-3003

**ACADEMY**  
2163 HOBBY MODEL KITS