

MESSERSCHMITT BF109E



1/32 Scale Series Kit No. JS-073



History

In 1933, before the advent of Me109, Willy Messerschmitt, the technical designer for BFW Co. (Bayerische-Flugzeuge-Werke) completed the design on one airplane. It was the 4 crew Bf108, which became the basis for the Me109 series. In the summer of 1934 the Messerschmitt designer team, employing the special features of Bf109, commenced the production of Me109 new fighter plane. Me109V-1, the first trial plane, made her maiden flight in September of 1935, and with the exception of her faulty landing gear her performance was very superior; for this trial plane was outfitted with the British Rolls Royce (Kestrel) V engine (695 Hp.). Subsequent models was changed to Junkers Jumo 210A engine (610 Hp.). On Model V-4, besides the two 7.9 mm machine guns, she was also armed with 20mm automatic cannon in the propeller shaft. The first mass produced planes was the Me109B which was assigned to the Spanish Civil War in 1937. In August of 1938 Me109C arrived in Spain and was tested under actual war condition. Me109D was born through the many combinations of Me109B and Me109V series and various types of engine. With the advent of E series the new Daimler-Benz DB601A engine was developed. This new engine is equipped with direct fuel injection system and supercharger, enabling to produce 1,150 Hp.. The E series was thus perfected with the combination of 3 blade constant speed propeller. The original model Me109V-14 conducted it maiden flight in the summer of 1938 and the first mass production of Me109E1 was outfitted with 7.9mm machine gun, replacing the 20mm automatic cannon. Subsequent to 1939 this Me109E-3 became the front line fighter, outfitted with 3 automatic cannon (whose barrel was passed through the propeller shaft) and 2 machine guns. In August 13, 1940 the Battle of Britain began and the E-3, the improved model of E-4, showed active service. The pilot seat protective armor plate was reinforced in E-4 and the range of visibility was improved. The automatic cannon on the nose was removed and 2 machine guns were armed onto the nose top and the wing armed with 2 automatic cannon. E-4N, the improved model of E-4, is outfitted with 1,200 Hp. DB601N engine and a great majority was assigned to the North Africa campaign. With special and filter on the intake, it was also outfitted with bomb mounting for ground support mission. The famous Germany ace pilots on the E model were Werner Mölders, Helmut Wick and Adolf Galland. On the short range observation planes... E-5, E-6 ... the armament was limited to 2 machine guns on the nose. To increase the cruising range on E-7, one 250 litre auxiliary fuel tank was mounted under the fuselage. With the various improvements and remodeling, E-8 was outfitted with DB601E engine (1,200 Hp.). E-9... fighter observation plane ... was armed with 2 machine guns and outfitted with camera equipments.

In 1940 the Me109F series made her appearance with improved DB601N engine with complete remodeling. In the latter part of 1942, with the aim to further improve its performance and armament, Me109G was produced with DB605A engine (1,475 Hp.) and heavily armed with 20mm automatic cannon in the both wings, two 13mm machine guns on the nose and one 20mm automatic cannon in the propeller shaft. The G series production amounted to 70% of the

total production of Me109's ... about 2,300 planes. Me109H was developed for stratospheric purpose but only a few showed action. Me109J was the model licensed to Hispano of Spain for production. The last model produced was Model K, with many improvements, but hardly showed any action by the time the war ended. Until the end of World War II 30,000 planes in the Me109 series was produced, amounting to more than 60% of Germany's single engine fighter planes and it was credited as the front line fighter. BFW was the name of the firm when the 109 was first perfected, and in 1938 it was renamed to Messerschmitt; therefore this model can be called in either Me109.

Characteristics

Overall Length	:	8.47m
Overall Width	:	9.71m
Engine	:	Daimler Benz DB601A (1,100 Hp.)
Armament	:	7.9mm Machine Gun x 2 20mm Automatic Cannon x 3
Maximum Speed	:	570 km/hr. (at 3,690m ceiling)
Ceiling Range	:	11,250m
Cruising Range	:	663km
Dead Weight	:	2,003kg.
Weight, Fully Armed	:	2,520kg.

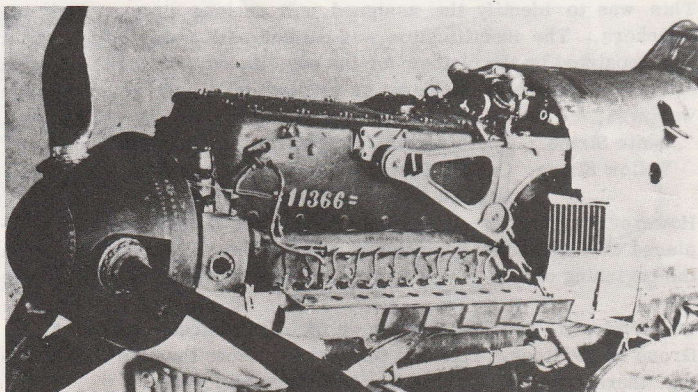
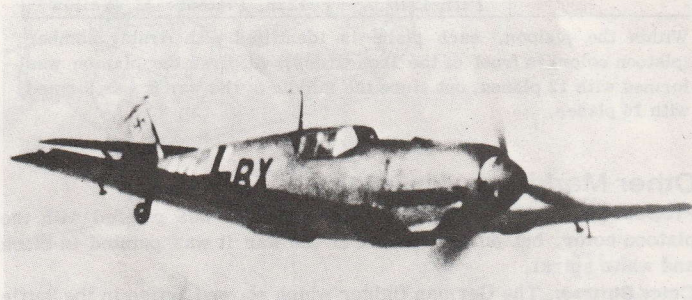

Markings on German Fighter Planes

In March 1935, Germany officially announced her nationality marking. The nationality marking was the Iron Cross (Balken-Krouz) and the Swastika (Haken-Krouz), the Nazi symbol. This marking was principally used until the end of World War II.

Plane Emblem: The formation of German airforce unit is based on the Geschwader (aircorps), Gruppe (group) and Staffel (platoon). Above this is the Geschwader that is grouped to form the Flieger-Corps (army corps), Luft-Flotten (air force) and below this there is the Kette (3 plane formation) and Schwarm (2 plane formation in Rotte 2 group).

Geschwader: JG, Gruppe: I, II, III (Roman Numeral) Staffel: 1 - 12 (Arabic Numeral)

Group (Gruppe) Marking



First Group

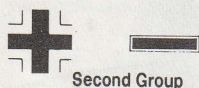

Second Group



Third Group



Third Group



Fourth Group

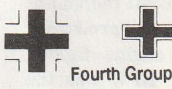

Fourth Group

Marking of Major Staff Planes



Air Corps Commander



Air Corps Sub-Commander



Operational Officer



Air Corps Training Staff



Aide



Group Commander



Group Sub-Commander



Group Training Staff

Platoon Color

Air Corps (Geschwader)	First Group (I Gruppe)	1 st. Platoon 2nd. Platoon 3rd. Platoon	White Red Yellow
	Second Group (II Gruppe)	4 th. Platoon 5 th. Platoon 6 th. Platoon	White Red Yellow
	Third Group (III Gruppe)	7 th. Platoon 8 th. Platoon 9 th. Platoon	White Red Yellow
	Fourth Group (IV Gruppe) Fall: 1940	10 th. Platoon 11 th. Platoon 12 th. Platoon	White Red Yellow

Within the platoon, each plane is identified with Arabic number (platoon color) in front of the Iron Cross. At first the platoon was formed with 12 planes, but since the middle of the war it was formed with 16 planes.

Other Markings

Propeller Spinner: During the early stage it was painted with the platoon color, but during the end of the war it was painted in black and white spiral.

Color Stripes: The German fighter which showed action in the Battle of Britain used various colors on the cowling and the wing tips. This was to identify the assigned unit on long distance high sea attackers. The identification was painted with water color, and it was repainted by the platoon for the specific day. Since the middle of the war the color stripes was painted on the tail to identify the war area.

White Stripe : North Africa, Mediterranean, Southern Russia

Yellow Stripe: Central Russia, Northern Russia, Scandinavia, English Channel, Home Defense Unit

However, in 1944 the yellow stripe for Home Defense Unit was replaced with red color or with red edge on the yellow stripe, and in the beginning of 1945 it was further changed to white stripe with blue edge.

Unit Marking: The unit marking on the nose indicated the Air Corp, Group and Platoon. This was unofficial. Other than the unit marking, there are markings to identify the specific pilots.

Messerschmitt Me109 E Armament

	Nose	Propeller Shaft	Main Wing	Engine
E - 1	MG - 17 7.9mm x 2		MG - FF 20mm x 2	DB601A 1, 150Hp.
E - 3	MG - 17 7.9mm x 2	MG - FF 20mm x 1	MG - FF 20mm x 2	DB601A 1, 150Hp.
E - 4	MG - 17 7.9mm x 2		MG - FF 20mm x 2	DB601A 1, 150Hp.
E - 5 Observation Model	MG - 17 7.9mm x 2			DB601A 1, 150Hp.
E - 6 Observation Model	MG - 17 7.9mm x 2			DB601N 1, 200Hp.
E - 7 Long Distance Model	MG - 17 7.9mm x 2		MG - FF 20mm x 2	DB601N 1, 200Hp.
E - 8	MG - 17 7.9mm x 2		MG - FF 20mm x 2	DB601E 1, 200Hp.

Convertible Parts

MG 17 (7.9mm Machine Gun)
E-1 (Early Model)

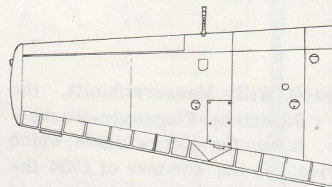

E-4/TROP Tropical Model

MGFF(20mm Automatic Cannon)
Other models except E-5, E-6.

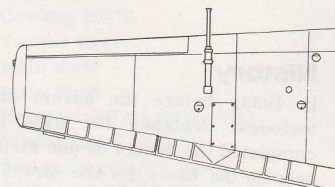

Other models except E-4/TROP.

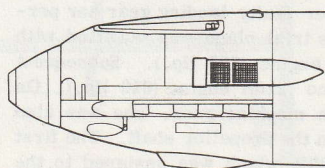

Spinner on Fighter Plane
Model E-1, E-3, E-4
(Including Bomber Model)

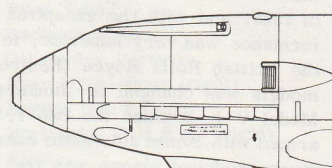

Spinner on Observation
Plane Model E-5, E-6, E-7

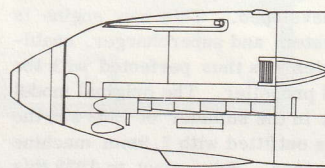

Fighter Bomber Model
E-1/B, E-3/B, E-4/B

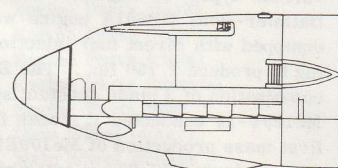

Long Distance Ground
Attack Model E-7

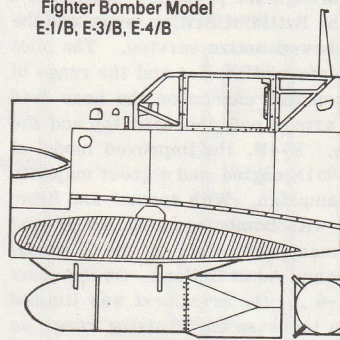

Canopy E-1, E-1/B
E-3, E-3/B

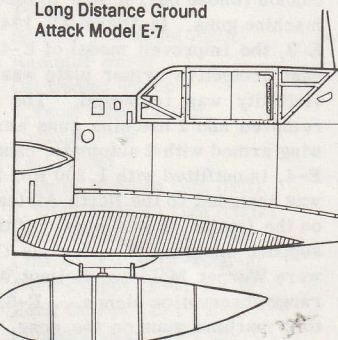

Canopy E-4, E-4/B,
E-4/TROP, E-5, E-6, E-7

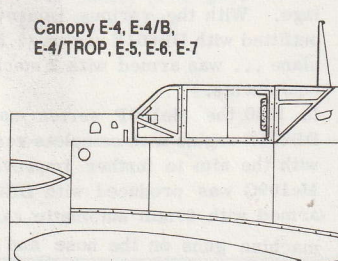
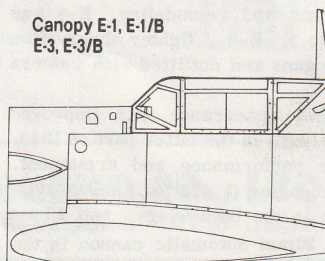

1 Engine Assembly(1)

* After cementing (51) to (52), cement (53) and (50).

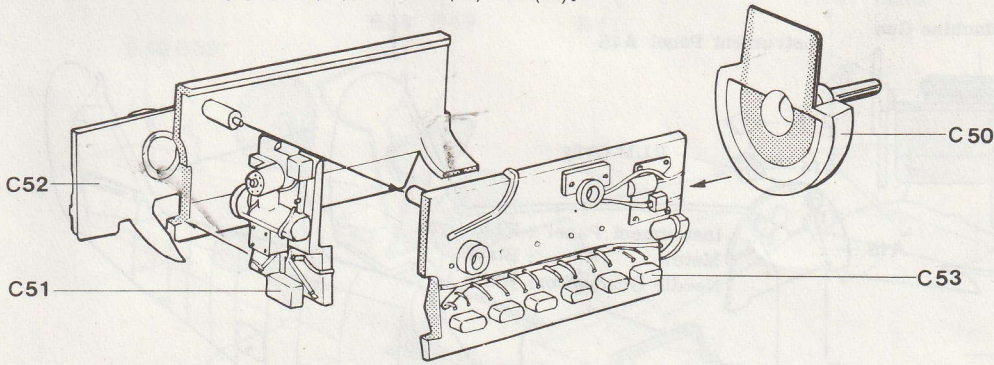

Before Assembling

- * Read full instructions first and assemble your kit following them.
- * Decide your model among the kit variations of E-1, E-1/B, E-3 E-3/B, E-4, E-4/B, E-5, E-6 and E-7.
- * Do not tear off parts from the stem, but cut them off carefully with nippers or tinsnips.
- * Unless instructed, use semi-gloss or mat finish paint for plastic.

2 Engine Assembly (2)

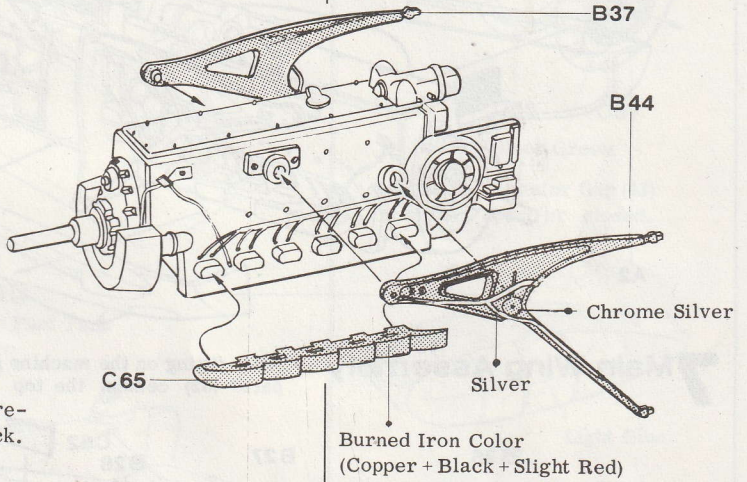
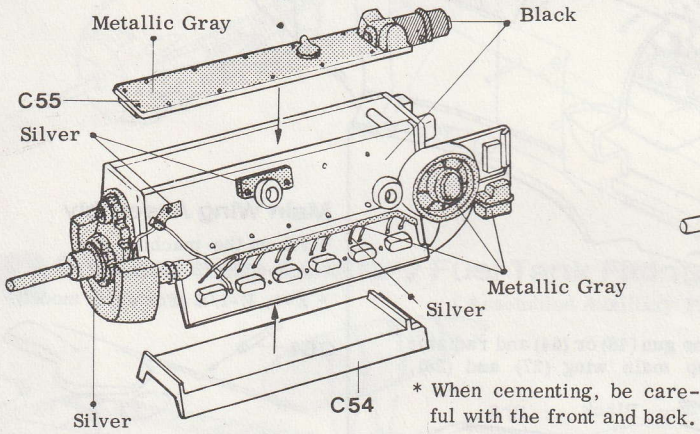

3 Machine Gun, Cockpit Assembly

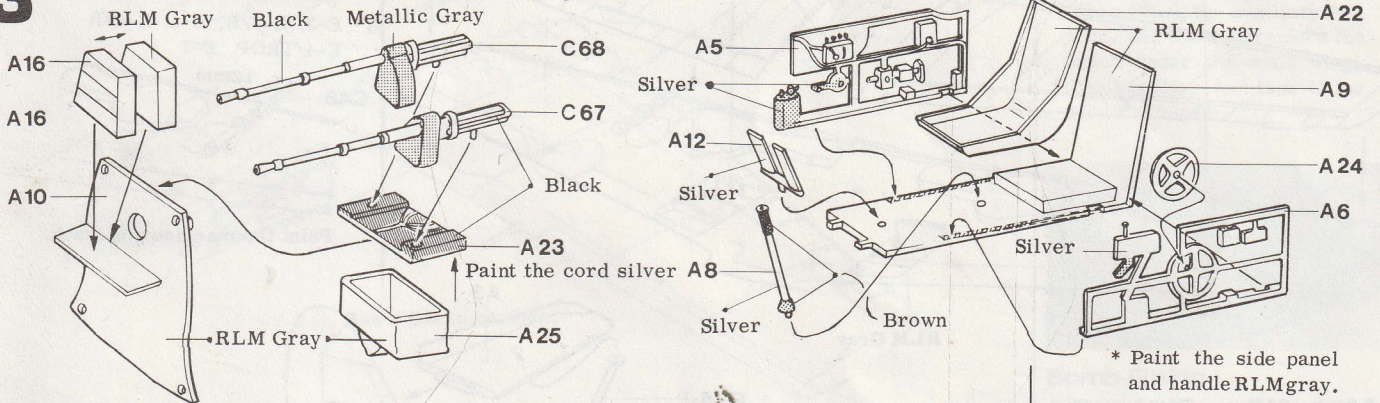

4 Engine & Cockpit Fitting

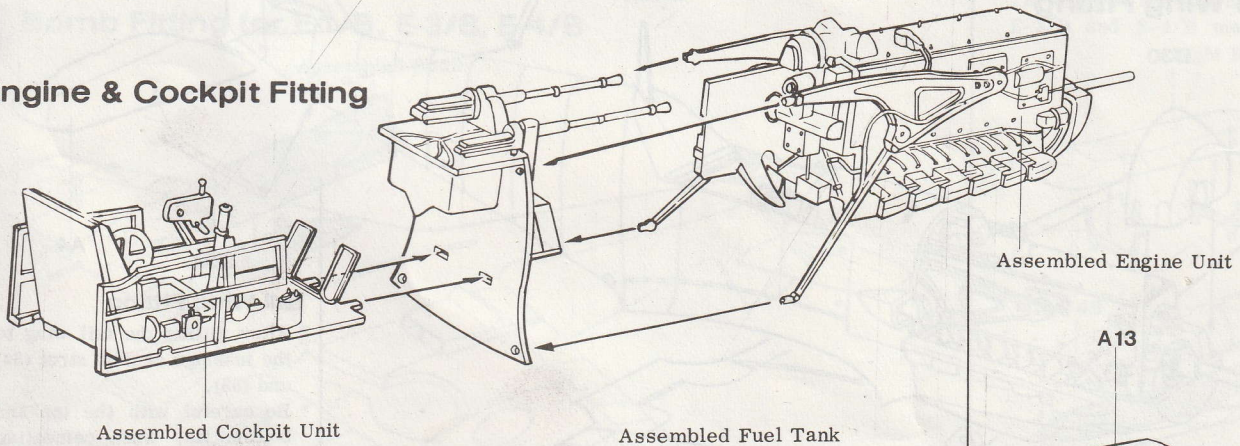

5 Fuel Tank Fitting

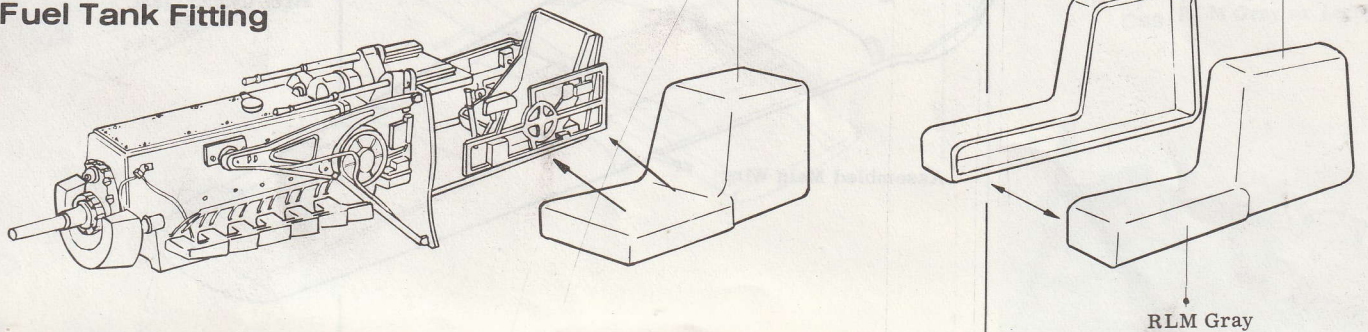

6 Fuselage Assembly

* Fit on the oil cooler parts (63) (42), assembled engine in 4 and instrument panel to the right fuselage and cement on the left fuselage.

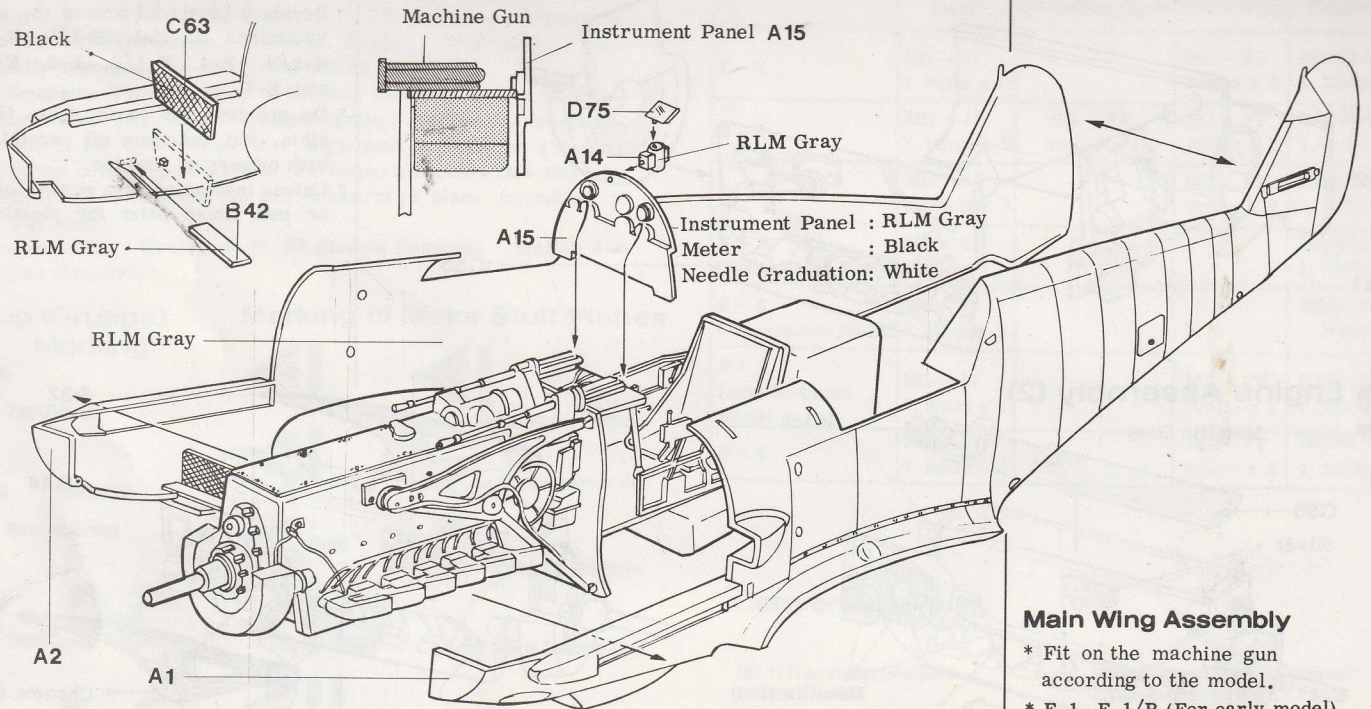

7 Main Wing Assembly

* After fitting on the machine gun (48) or (64) and radiator parts (62) cement the top main wing (27) and (28).

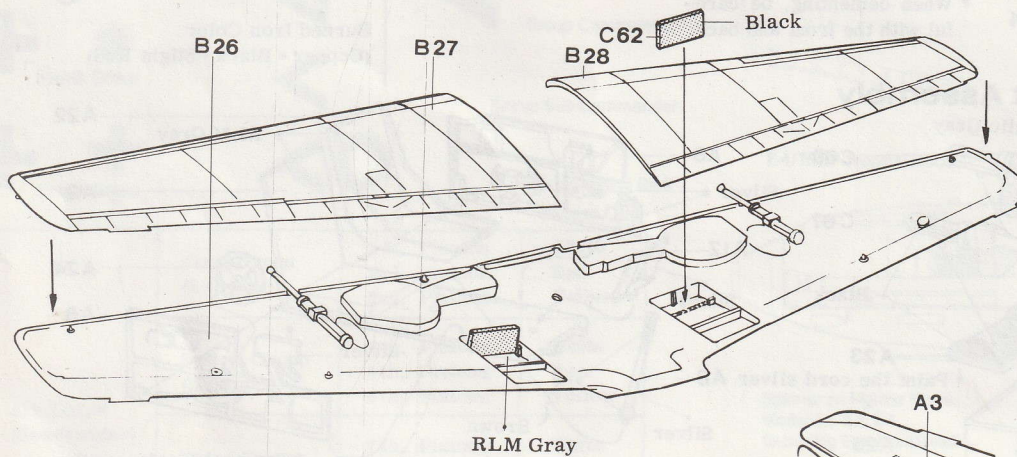

Main Wing Assembly

* Fit on the machine gun according to the model.
* E-1, E-1/B (For early model)



* E-3, E-3/B, E-4, E-4/B
E-4/TROP, E-7

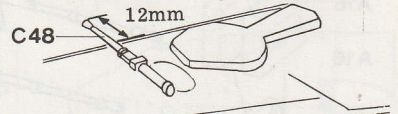

Paint the machine gun black.

8 Main Wing Fitting

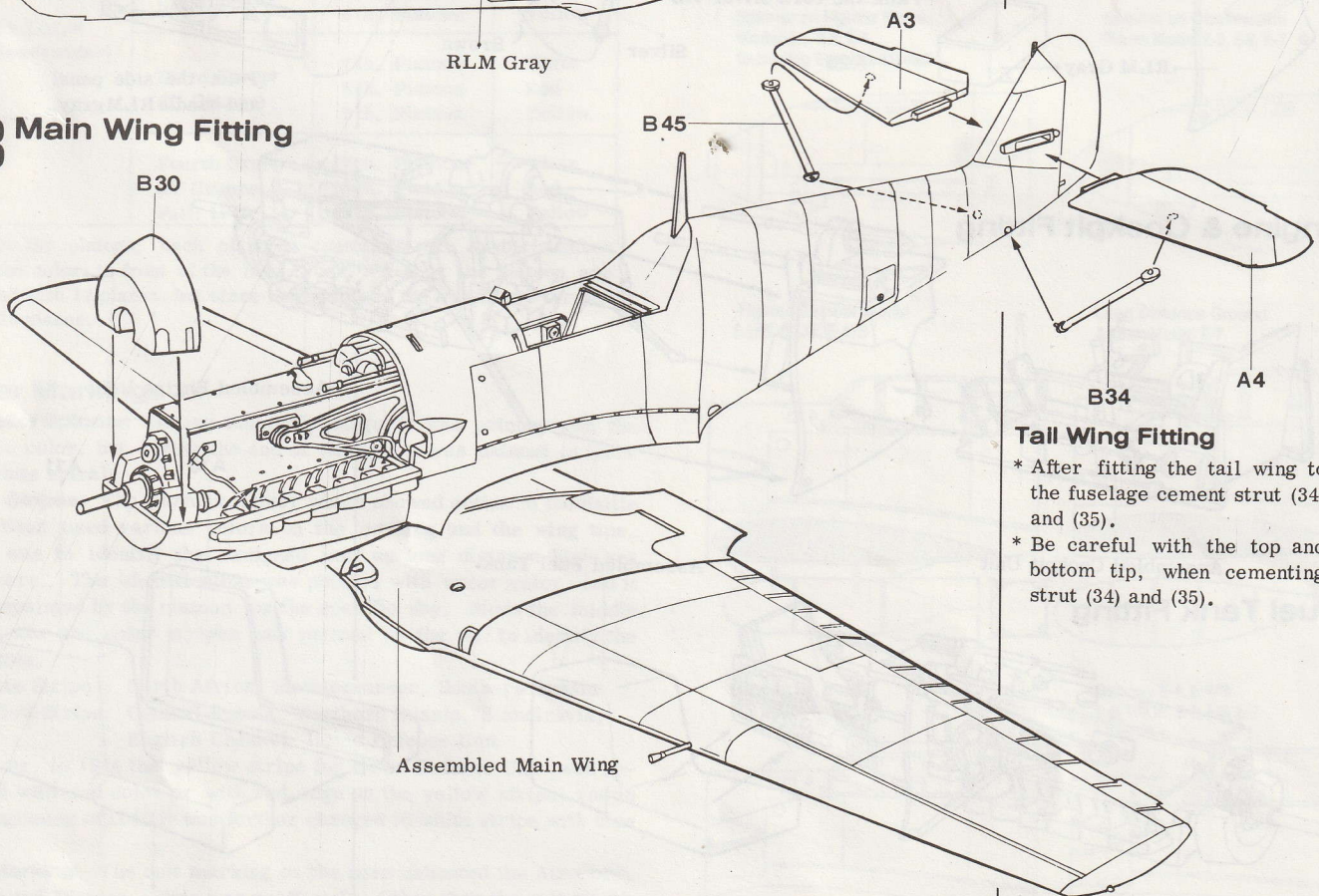

Tail Wing Fitting

* After fitting the tail wing to the fuselage cement strut (34) and (35).

* Be careful with the top and bottom tip, when cementing strut (34) and (35).

9 Main Landing Wheel & Tail Wheel Fitting

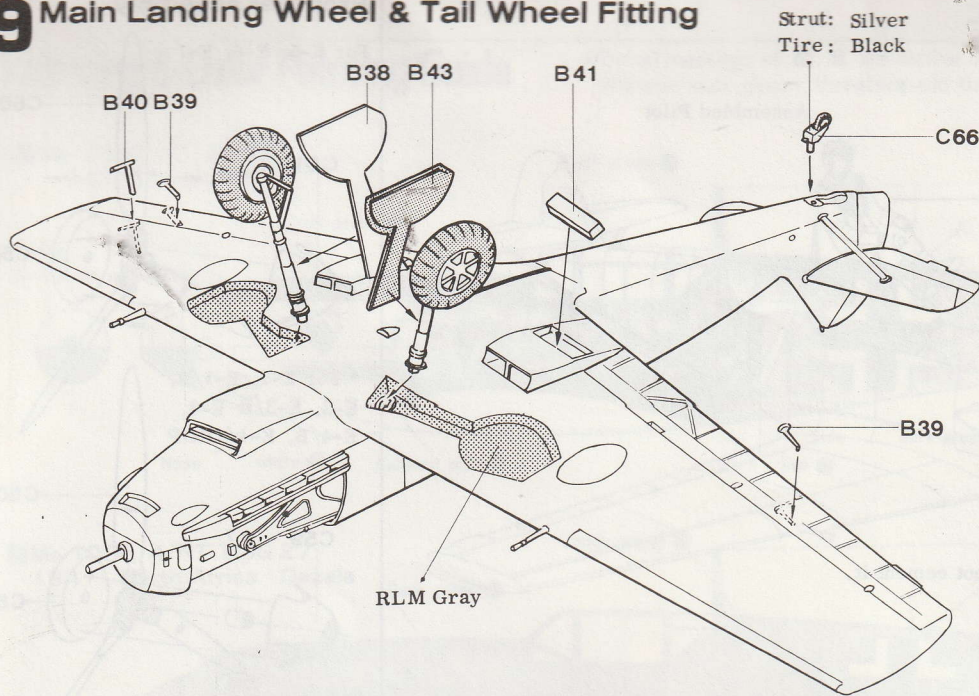

Main Landing Wheel

* Assemble 2 sets of main landing wheel.

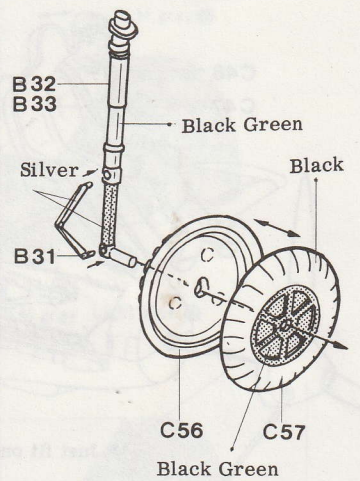

* Cement the radiator flap (41) in either open or closed.

10 E-7 Outfitting Auxiliary Fuel Tank Fitting

Assembled Auxiliary Fuel Tank

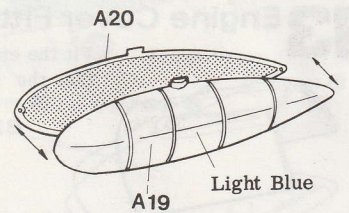
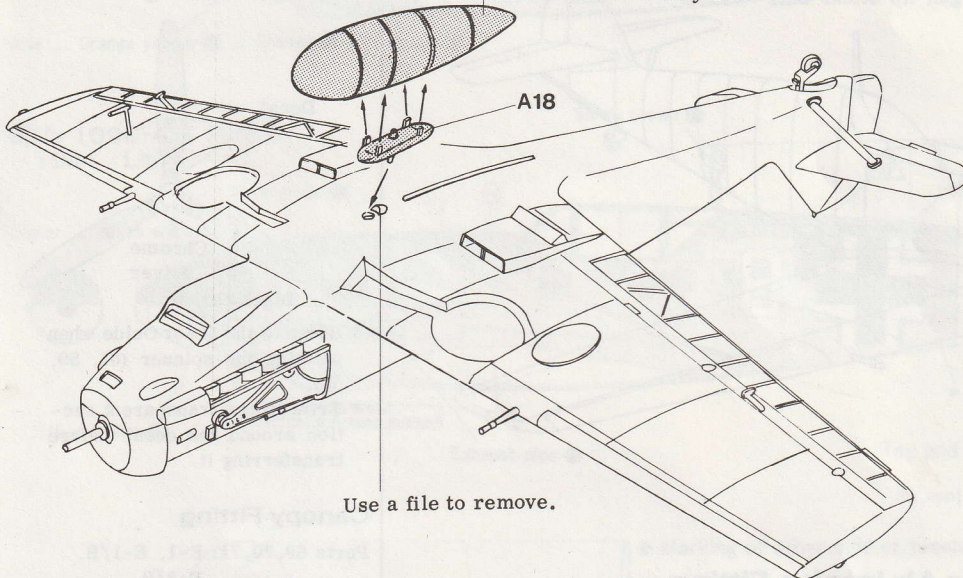

Auxiliary Fuel Tank Fitting

* When fitting the auxiliary fuel tank, use a file to remove the notch under the main wing.
* The auxiliary fuel tank is for only E-7 model.



11 Bomb Fitting for E-1/B, E-3/B, E-4/B

Assembled Bomb

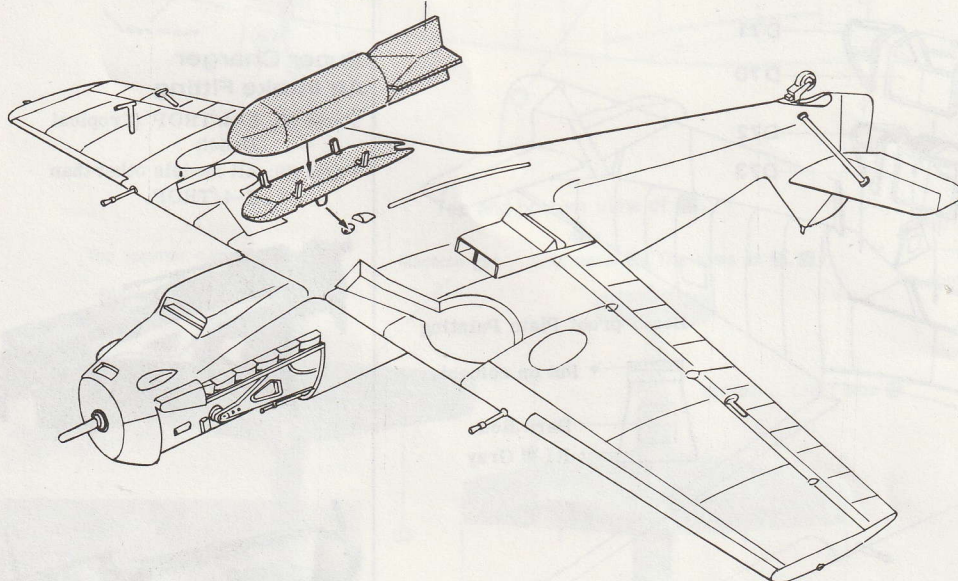

Bomb Fitting

* The bomb is for only E-1/B, E-3/B and E-4/B models.

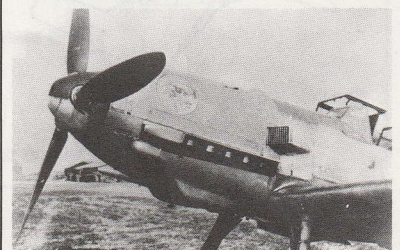
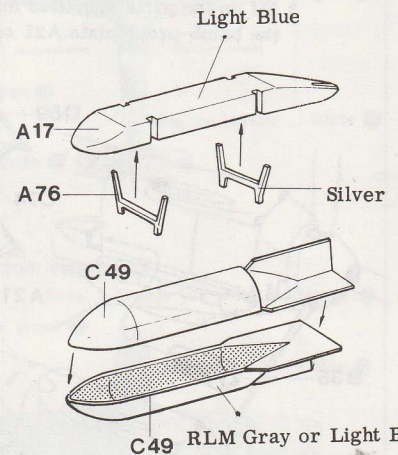

12 Propeller, Pilot Fitting

* Refer to page 7 for pilot painting.

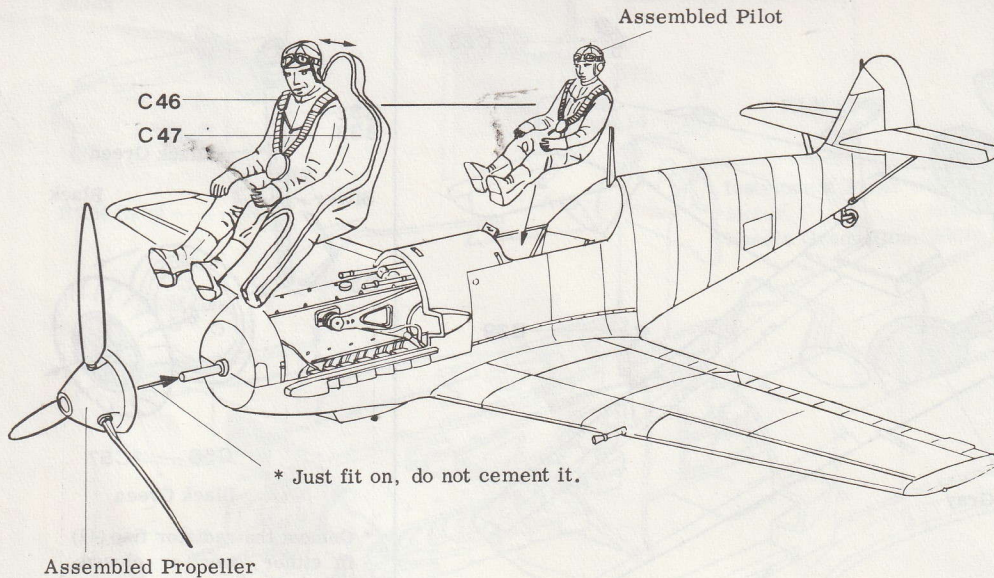

13 Engine Cover Fitting (Do not cement.)

* Fit the engine cover to the fuselage so that the machine gun tip sticks out.

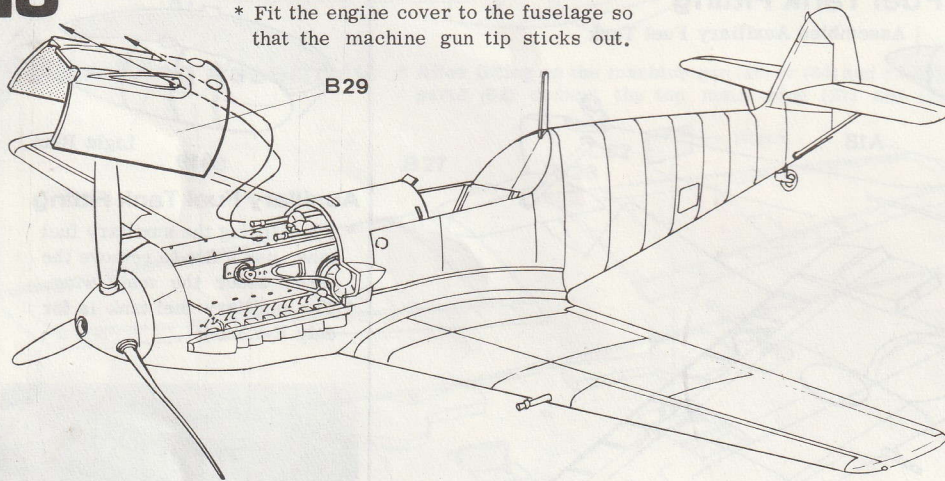

14 Canopy, Supercharger Air Intake Fitting

* Fit on the parts specified for the model. Fit the bomb-proof plate A21 only to part D73.

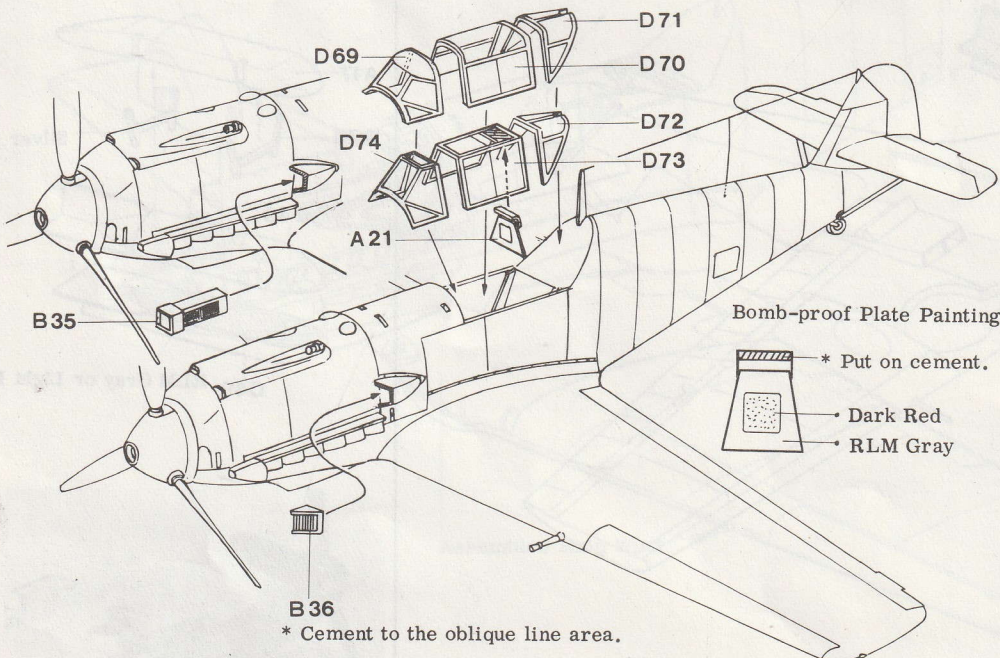

Bomb-proof Plate Painting

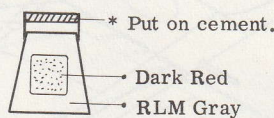

Propeller Assembly

For E-5, E-6, E-7

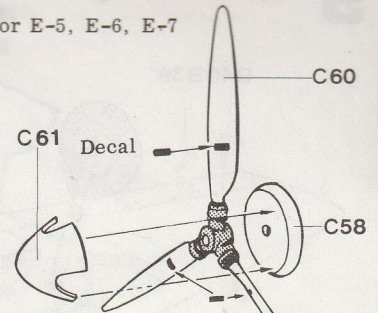

* For E-1, E-1/B, E-3, E-3/B E-4, E-4/B, E-4/TROP

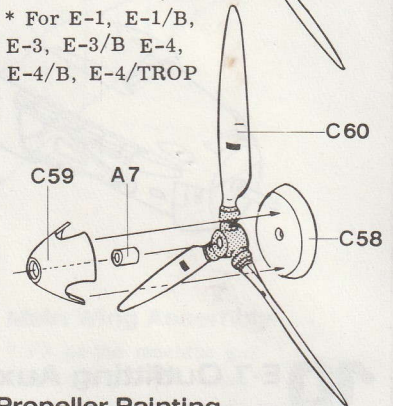

Propeller Painting

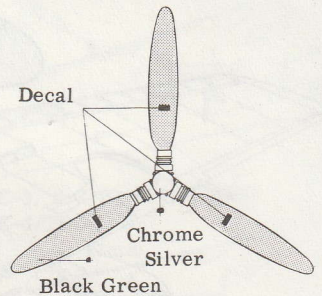

* Refer to the Color Guide when painting the spinner (61, 59, 58).

* Trim off the transparent section around the decal before transferring it.

Canopy Fitting

Parts 69, 70, 71: E-1, E-1/B, E-3/B

Parts 72, 73, 74: E-4, E-4/B, E-4/TROP
E-5, E-6, E-7

Super Charger Air Intake Fitting

Parts 35: E-4/TROP (Tropical Model)

Parts 36: All models other than E-4/TROP.

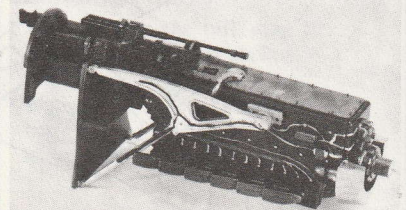

Marking & Color Painting Guide

★Detail markings of **1**, **2** are similar to those of **3**.
White is semi-glossy, therefore add flat base **30** a little bit in it.

1 Me 109E-3 I/JG 52 1940 France

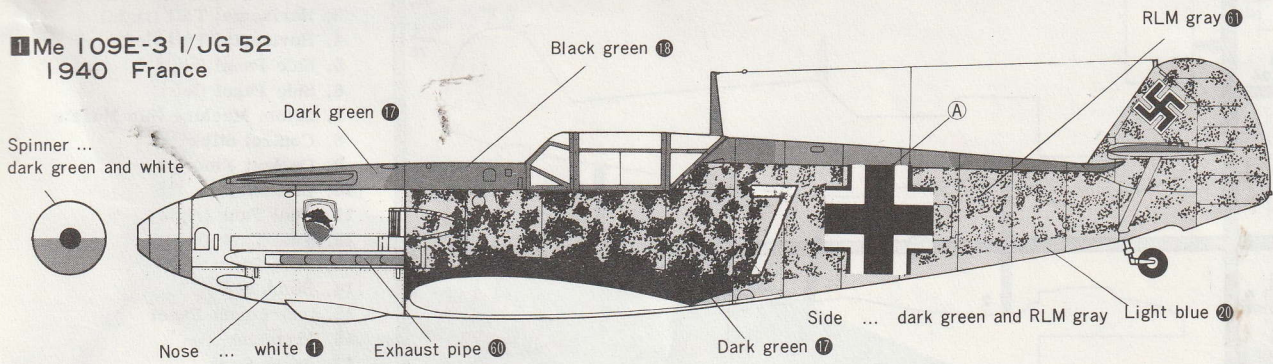

2 Me 109E-4/NT I/JG 27 1941 North Africa Gazala

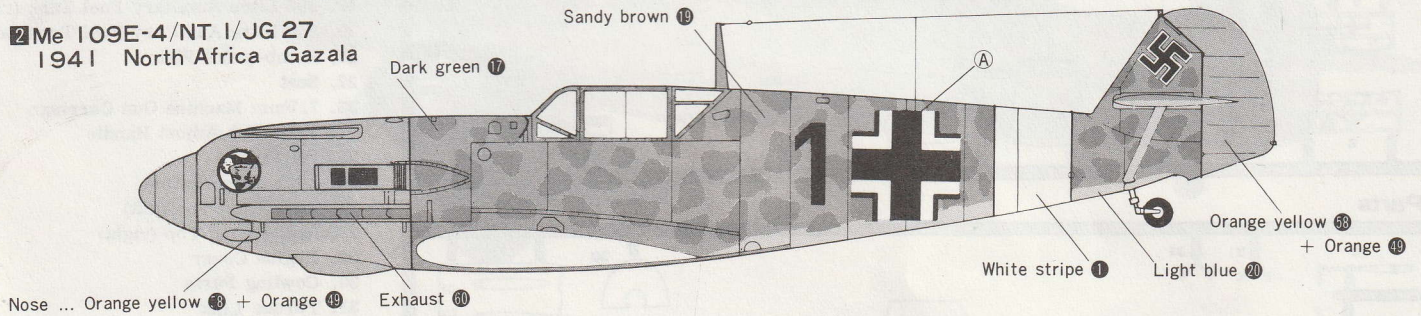

3 Me 109E-4/T I/JG 27 1941 Libya

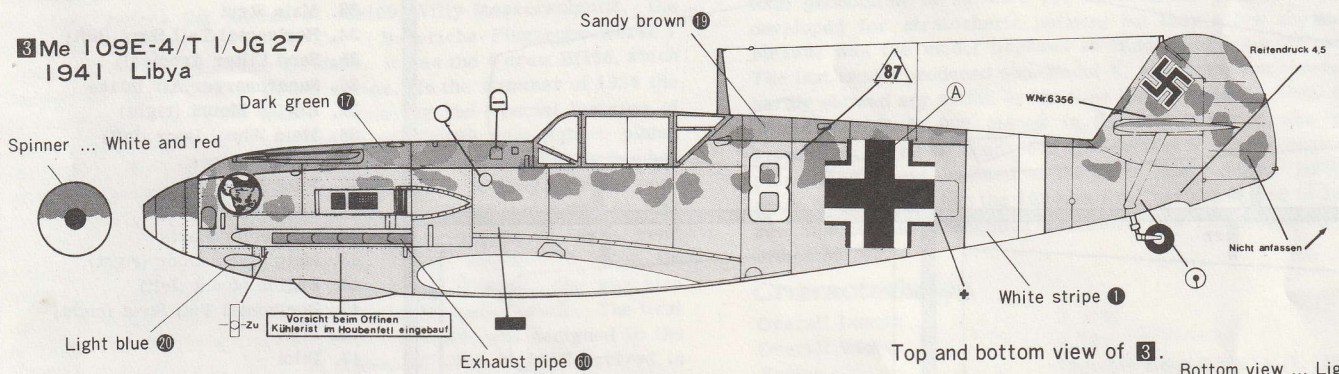

Top and bottom view of **3**.

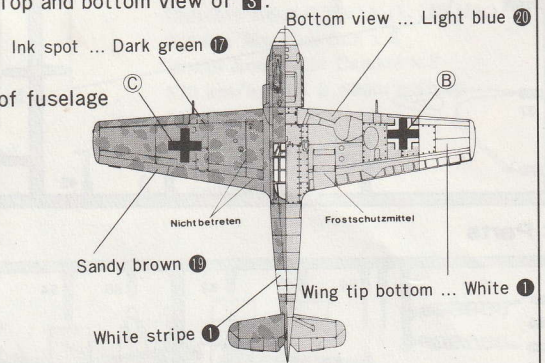

※ Marking of other side of fuselage

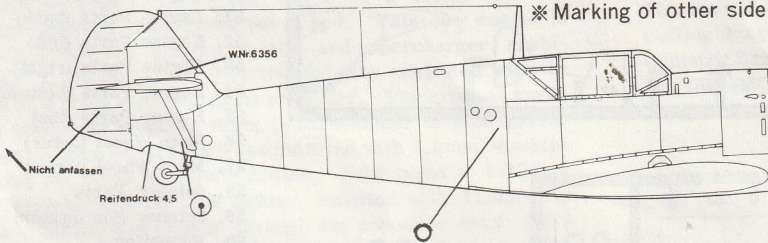

Top and bottom view of **1**.

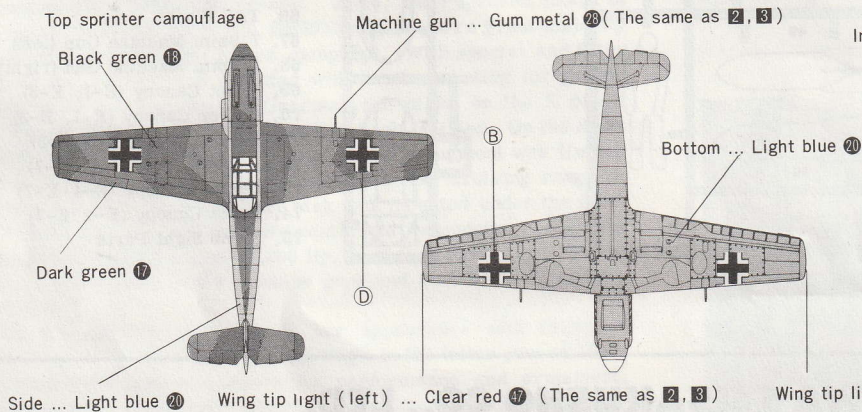

Top and bottom view of **2**.

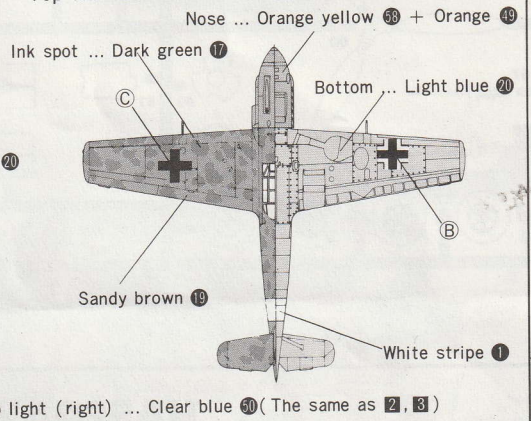

A Parts

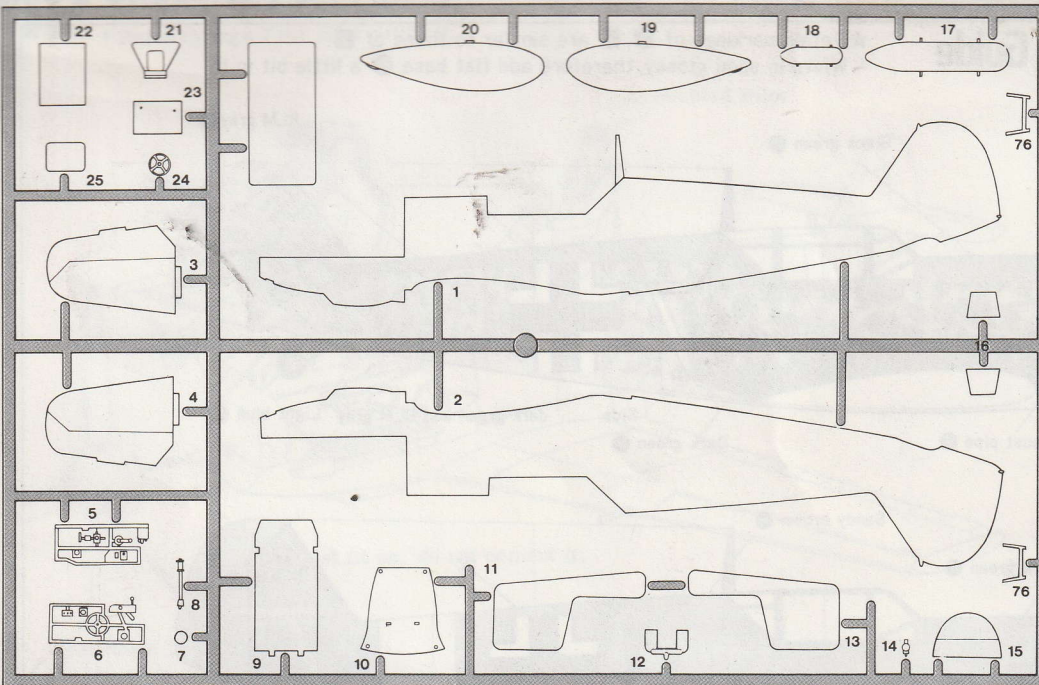

Parts

1. Fuselage (left)
2. Fuselage (right)
3. Horizontal Tail (right)
4. Horizontal Tail (left)
5. Side Panel (right)
6. Side Panel (left)
7. 20mm Machine Gun Muzzle
8. Control Stick
9. Cockpit Floor
10. Bulkhead
11. Fuel Tank (right)
12. Fuel Tank (left)
13. Foot Pedal
14. Bomb Sight
15. Instrument Panel
16. Magazine
17. Bomb Rack
18. Auxiliary Fuel Tank Rack
19. 250 Litre Auxiliary Fuel Tank (right)
20. 250 Litre Auxiliary Fuel Tank (left)
21. Bomb-proof Plate
22. Seat
23. 7.9mm Machine Gun Carriage
24. Trim Tab Adjust Handle
25. Oil Tank

B Parts

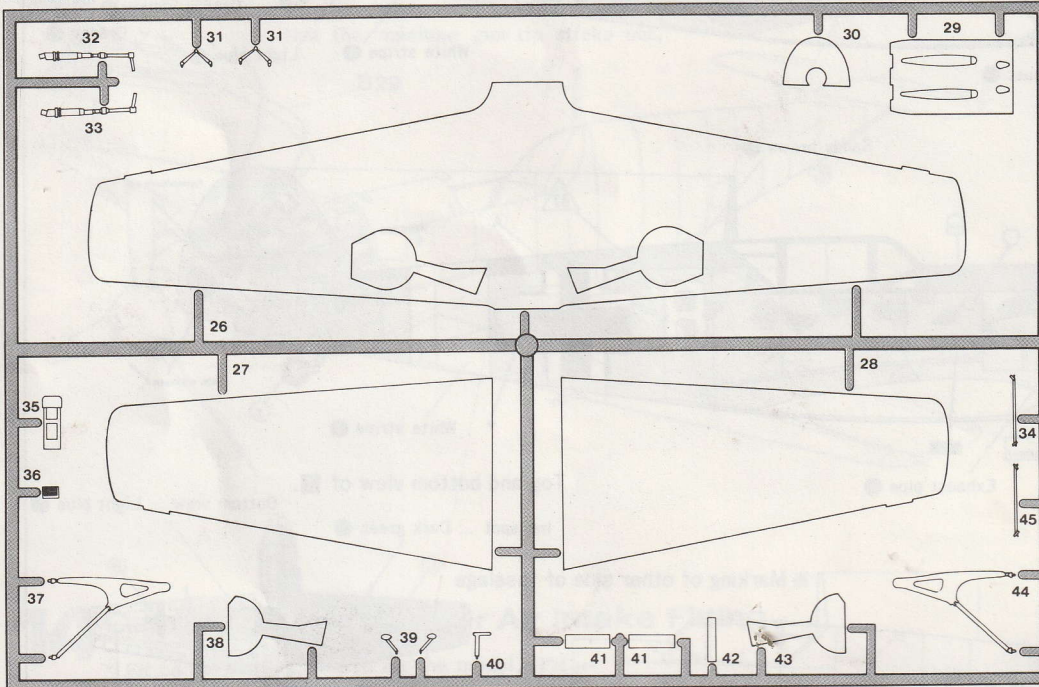

26. Main Wing Bottom
27. Main Wing Top (left)
28. Main Wing Top (right)
29. Engine Cover
30. Cowling Parts
31. Torque Link
32. Main Strut
33. Main Strut
34. Horizontal Tail Strut (left)
35. Sand Filter (tropical)
36. Supercharger Air Intake
37. Engine Mount (right)
38. Main Wheel Door (left)
39. Mass Balance
40. Pitot Tube
41. Radiator Flap
42. Oil Cooler Parts
43. Main Wheel Door (right)
44. Engine Mount (left)
45. Horizontal Tail Strut (right)
46. Pilot
47. Pilot
48. 20mm Machine Gun
49. 250kg. Bomb
50. Engine Parts (front)
51. Engine Parts (back)
52. Engine Parts (left)
53. Engine Parts (right)
54. Engine Parts (bottom)
55. Engine Parts (top)
56. Main Wheel (outer)
57. Main Wheel (inner)
58. Spinner Parts
59. Spinner (for fighter)
60. Propeller
61. Spinner (for scout plane)

C Parts

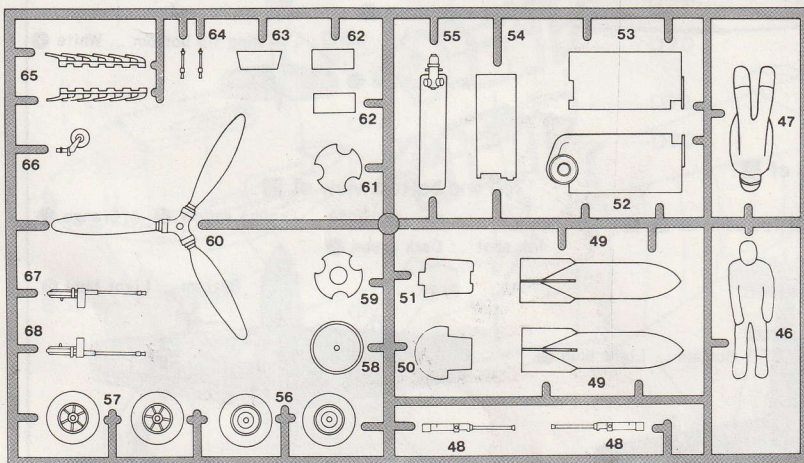

D Parts

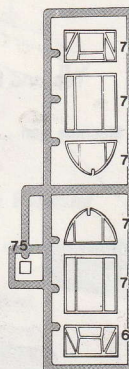

62. Radiator Parts
63. Oil Cooler Parts
64. 7.9mm Machine Gun
65. Exhaust Pipe
66. Tail Wheel
67. 7.9mm Machine Gun (left)
68. 7.9mm Machine Gun (right)
69. Front Canopy (E-1, E-3)
70. Center Canopy (E-1, E-3)
71. Back Canopy (E-1, E-3)
72. Back Canopy (E-4 E-7)
73. Center Canopy (E-4 E-7)
74. Front Canopy (E-4 E-7)
75. Bomb Sight Parts

Messerschmitt Me109E



1/32 スケール メッサーシュミット Me109E

《ハセガワ カラーガイド》

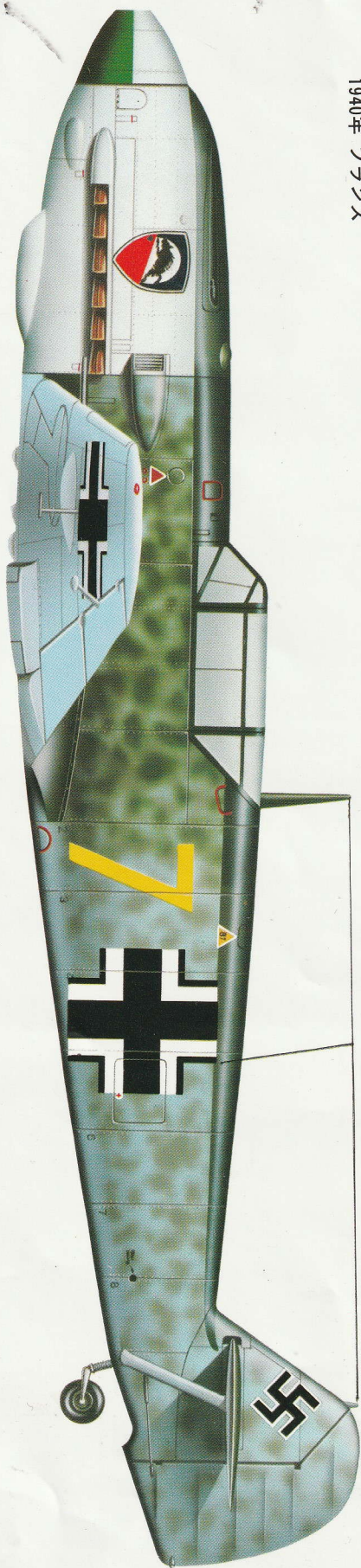

■ Me109E-3 I/JG52
1940年 フランス



■ Me109E-4/NT I/JG27
1941年 北アフリカ ギャザラ

詳しい塗装解説は組立説明図を
ごらんください。

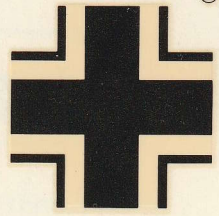
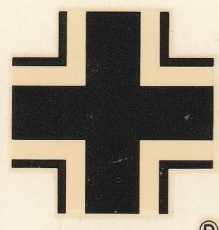
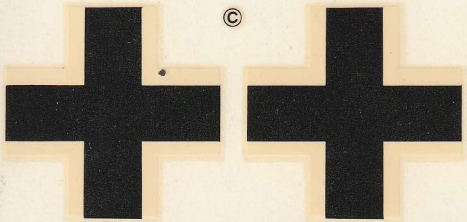
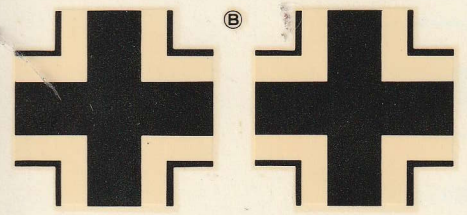
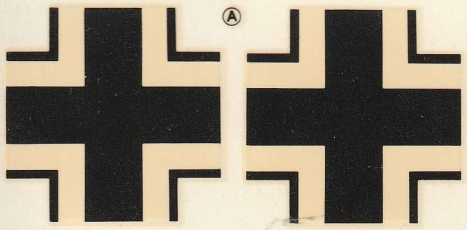

881

771

—Heirichtschieben—

			WN 3361	Nicht betreten
			WN 3361	Nicht betreten
			WNr.6356	Nicht betreten
			WNr.6356	Nicht betreten



Frostschutzmittel Nicht anfassen ↗
Frostschutzmittel Nicht anfassen ↘
+ Rettendruck 4.5

Vorsicht beim Öffnen
Kühler ist an Heubenteil eingebaut

BF-109E

MADE IN JAPAN