

BAC Lightning F.53K/T.55K Kuwait Air Force

Download full guide from www.uprise-decal.ru

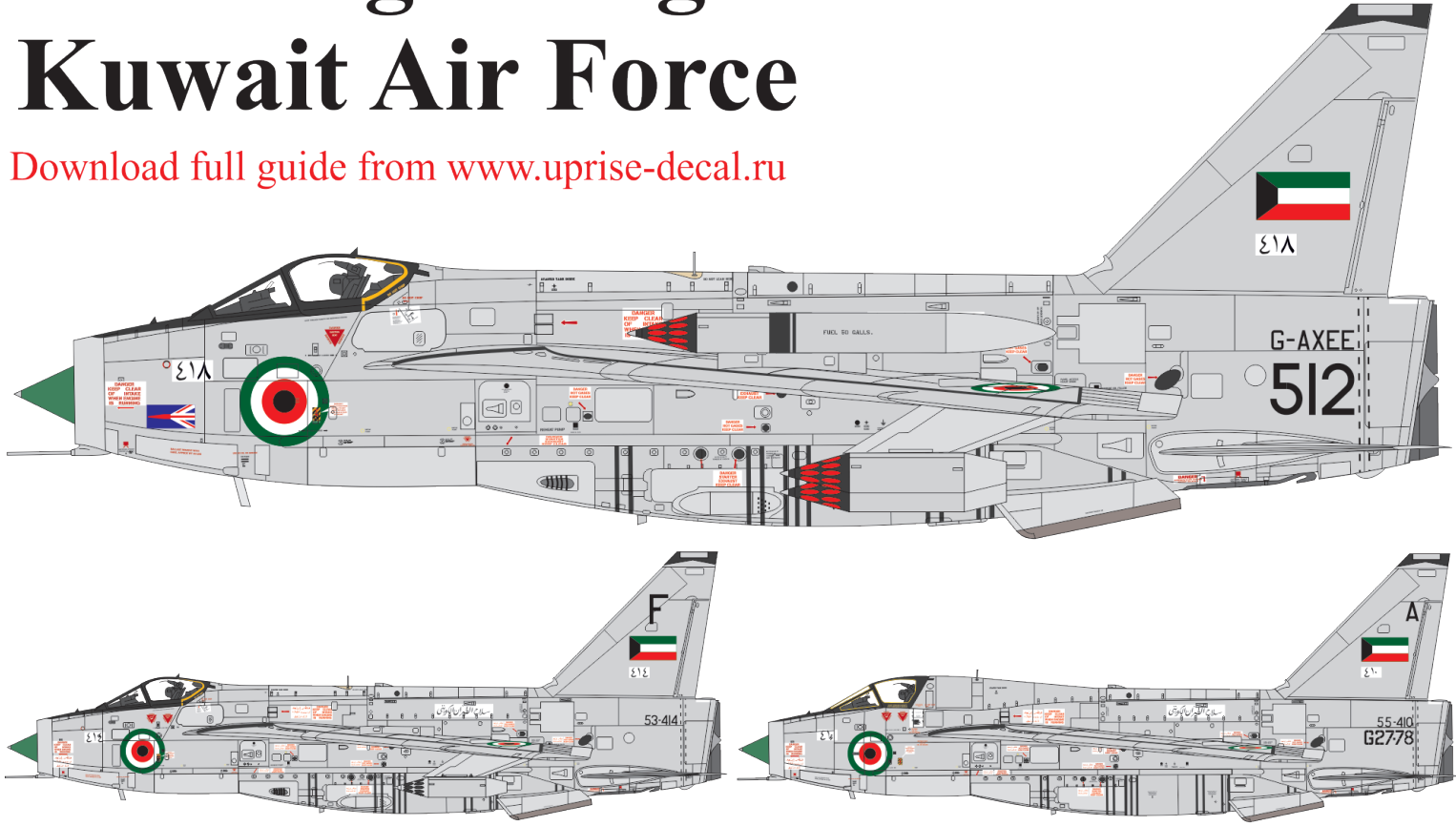

UR72292 UR48292 UR32292

Vizit to www.uprise-decal.ru for more decal sets...

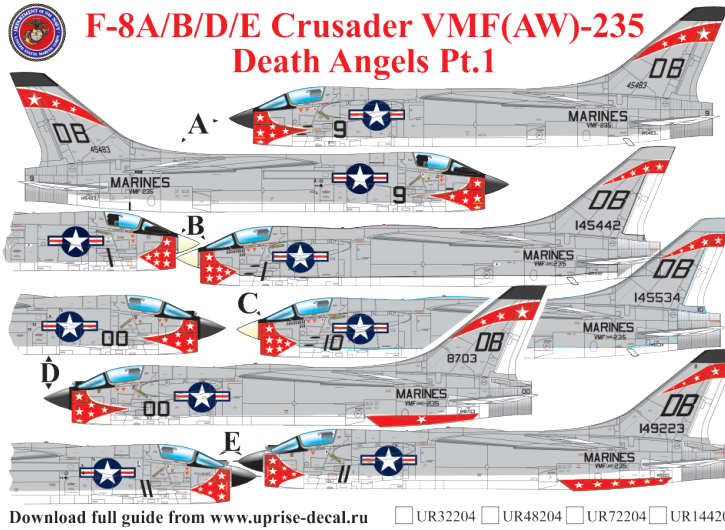

F-8A/B/D/E Crusader VMF(AW)-235 Death Angels Pt.1

Download full guide from www.uprise-decal.ru UR32204 UR48204 UR72204 UR144204

F-14A Tomcat VF-111 "Sundowners" Hi-Viz Super CAG and Miss Molly

A. F-14A-100GR, Bu. No. 160660, December 1986

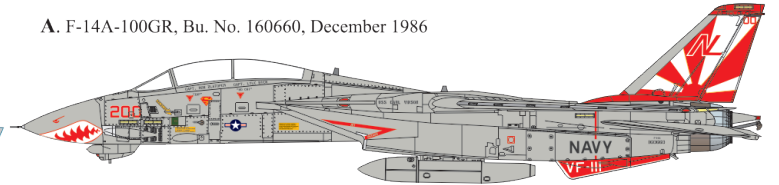

B. F-14A-125GR, Bu. No. 161621, December 1999

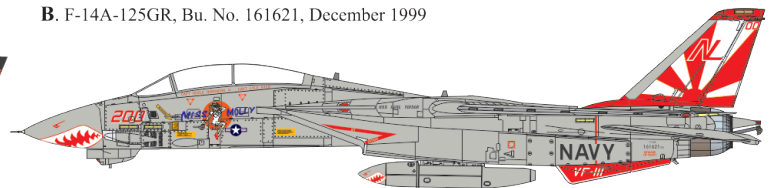

Download full guide from www.uprise-decal.ru UR144248 UR72248 UR48248 UR32248

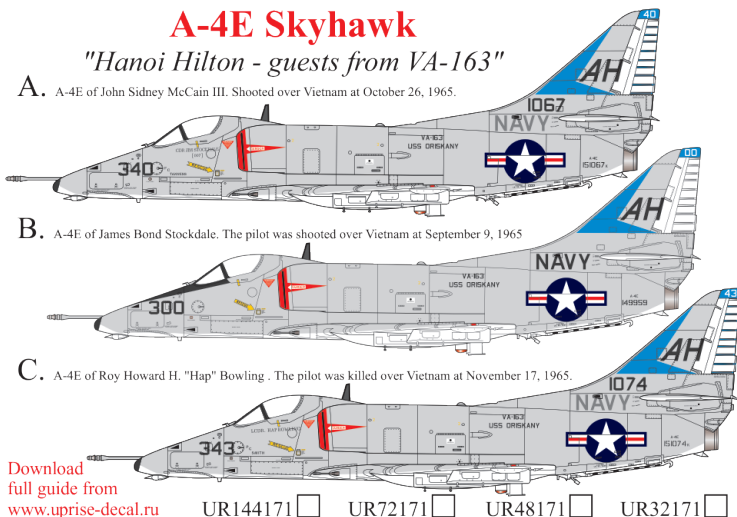

A-4E Skyhawk

"Hanoi Hilton - guests from VA-163"

A. A-4E of John Sidney McCain III. Shot over Vietnam at October 26, 1965.

B. A-4E of James Bond Stockdale. The pilot was shot over Vietnam at September 9, 1965

C. A-4E of Roy Howard H. "Hap" Bowling. The pilot was killed over Vietnam at November 17, 1965.

Download full guide from www.uprise-decal.ru

UR144171 UR72171 UR48171 UR32171



F-4B/N/J "Phantom-II" VF-84

Download full guide from www.uprise-decal.ru

UR72198 UR48198 UR32198

A. BAC Lightning F.53K, s/n 53-418 marked as G-AXEE on Paris Air Show '69. Now is located in Educational Science Museum, Kuwait.

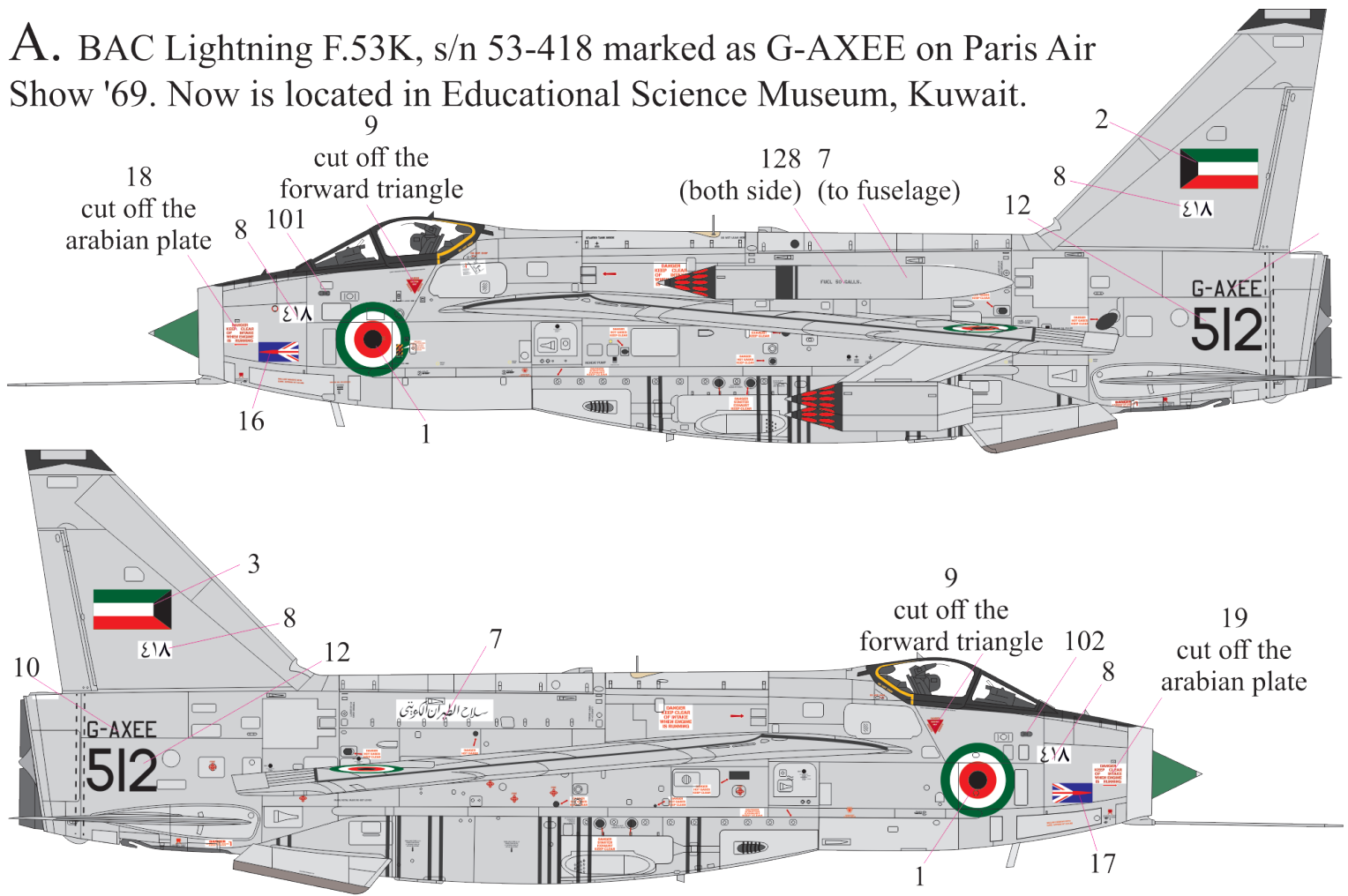

B. BAC Lightning F.53K, s/n 53-414, July 30, 1969. Crashed, 10 April 1971, on approach to Al Mubarak Air Base (the military airfield at Kuwait International Airport) into shanty town, three civilians killed. Pilot, Lieutenant Abdulwahab Abdulrazaq, died on the way to hospital.

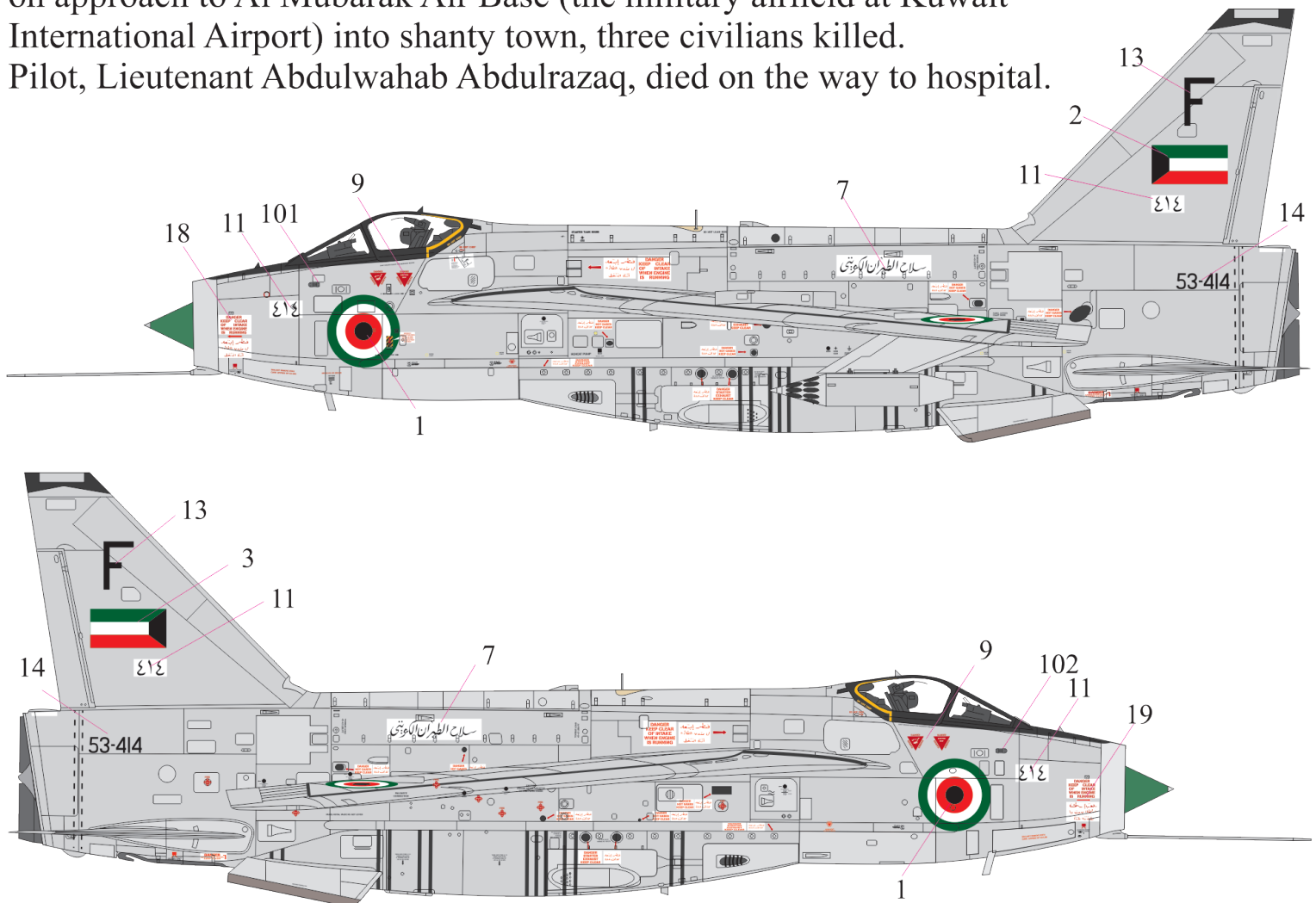

C. BAC Lightning T.55K, s/n 55-410, the first Kuwaiti T.55, from Warton AFB in July 1968. This T.55K was damaged during the 1991 coalition bombing campaign «Desert Storm», when Iraq had occupied Kuwait.

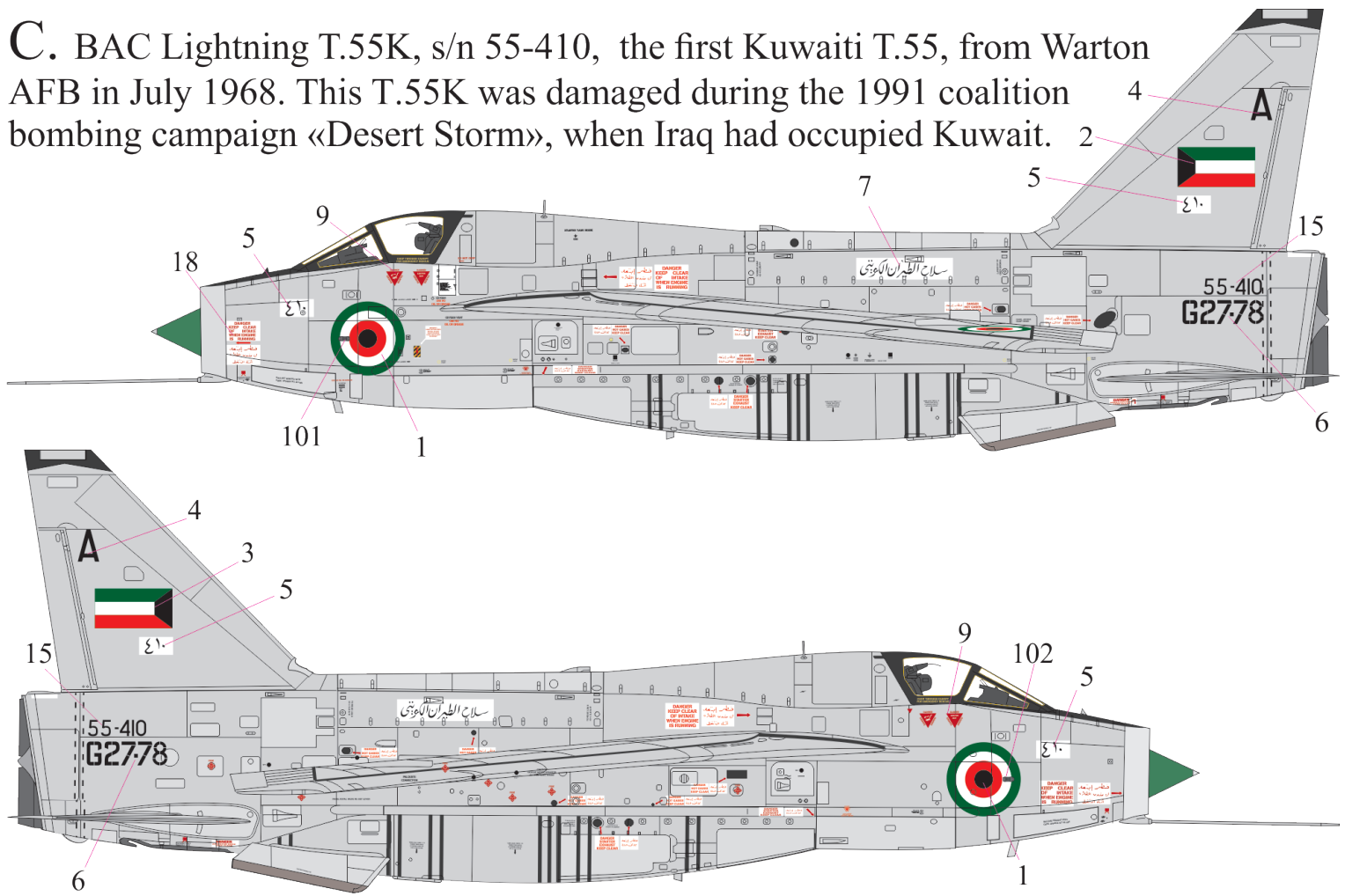

A. BAC Lightning F.Mk.53K G-AXEE. **Attention!** Cut all white plates with arabian language, but the red arrows are stay on the positions. / **Внимание!** Удалите все белые таблички с арабским языком. Но при этом, все красные стрелки оставьте на своих позициях.

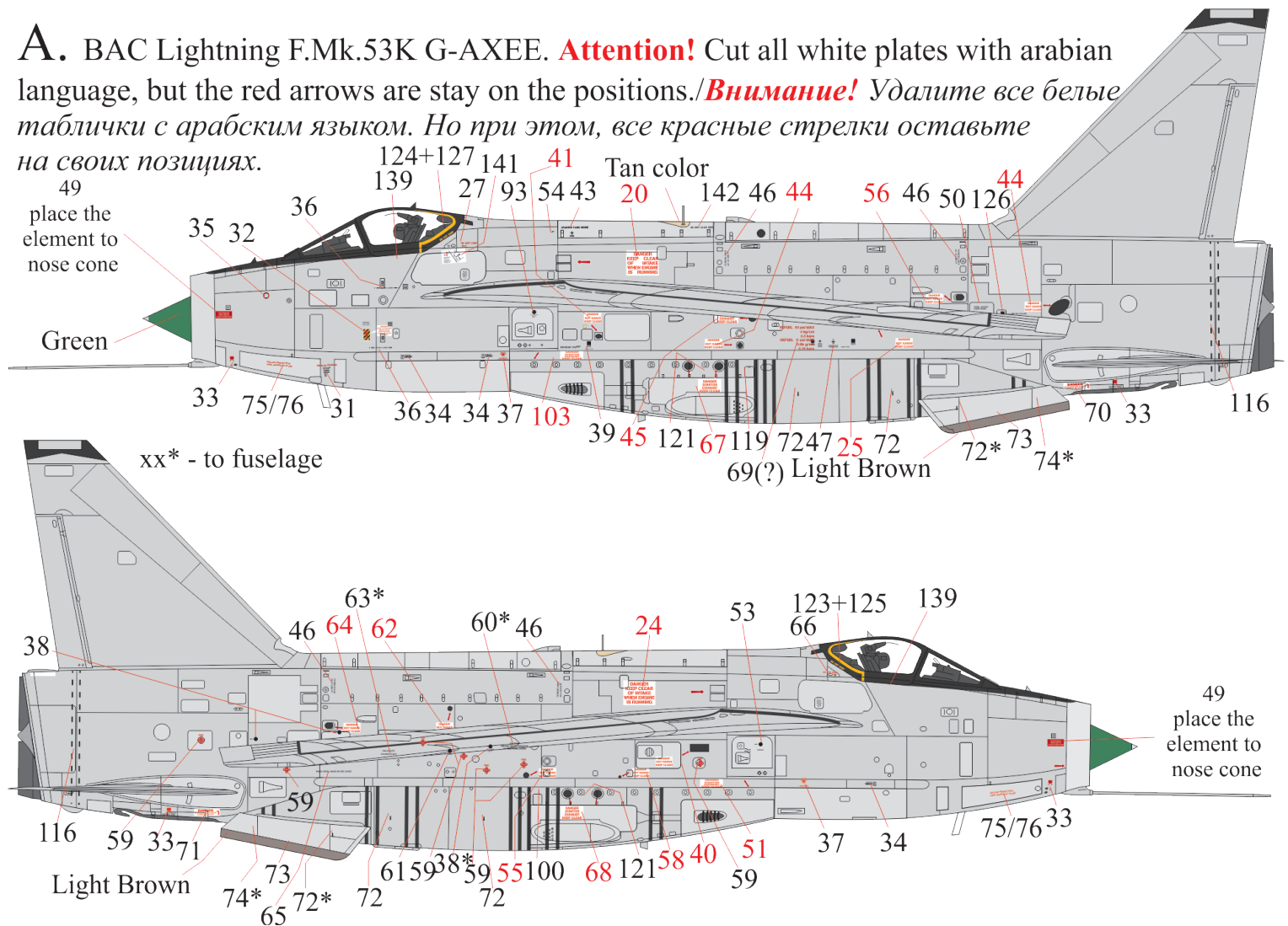

B. BAC Lightning F.Mk.53K, s/n 53-414.

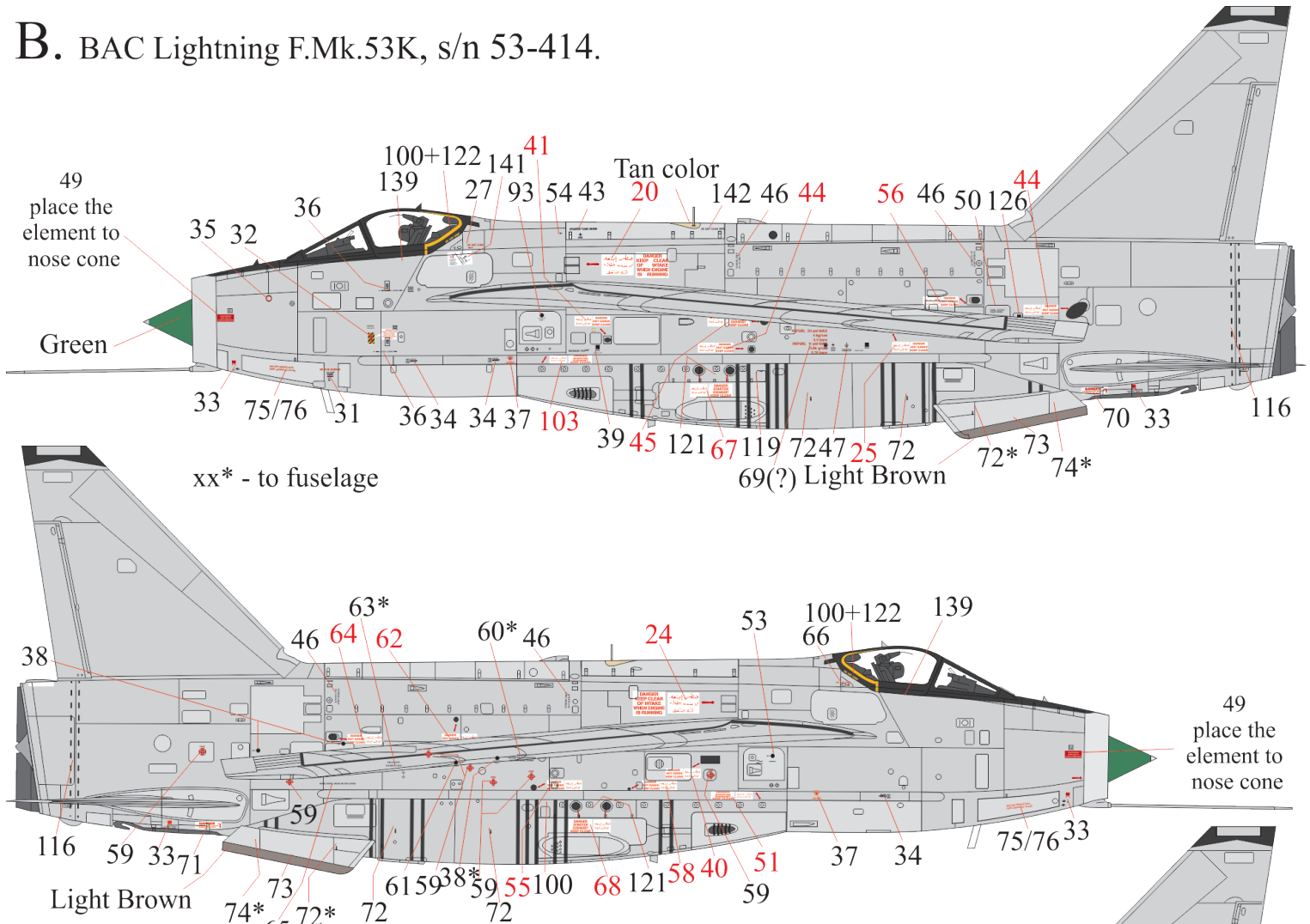

C. BAC Lightning T.55K, s/n 55-410.

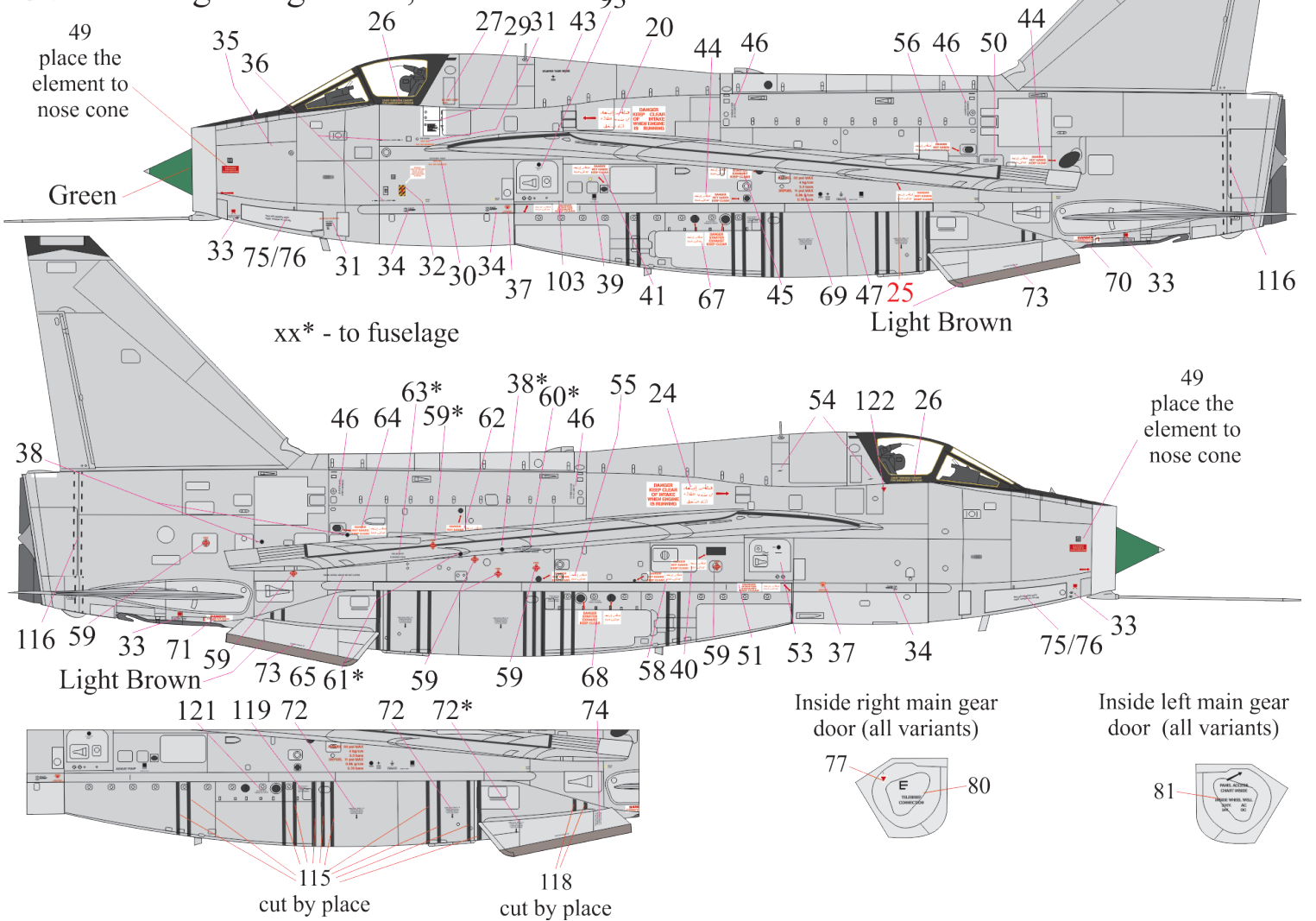

A/B/C top/bottom view

** - recommended sequence:

- right wing: 113/114/105/108/109/106

- left wing: 112/114/105/108/111/110

- cut by place or use spare line

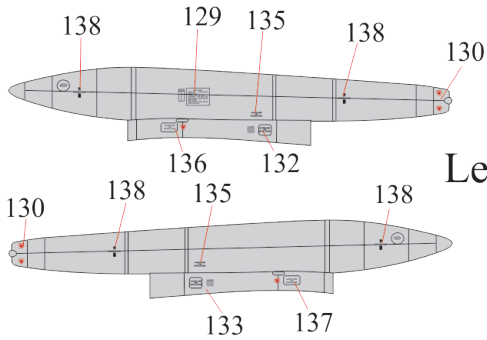
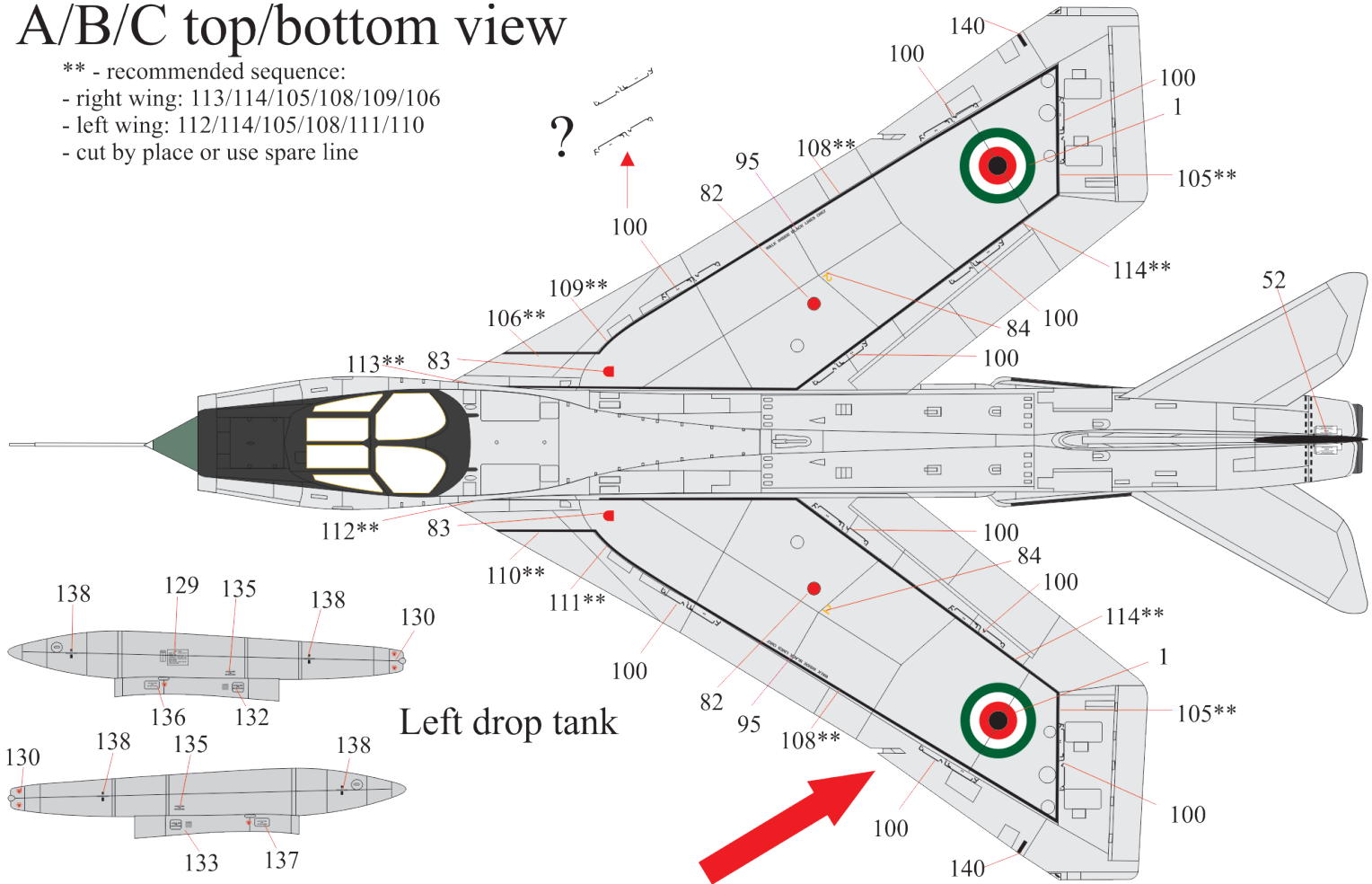

Left drop tank

Top view drop tank

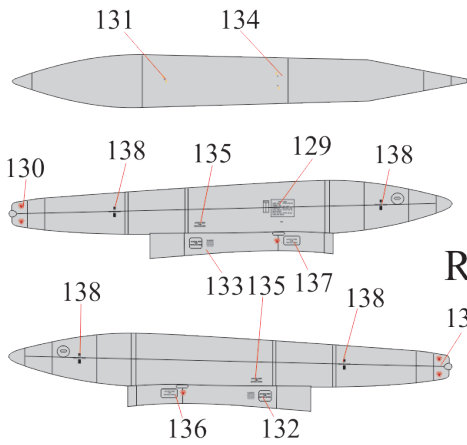

Right drop tank

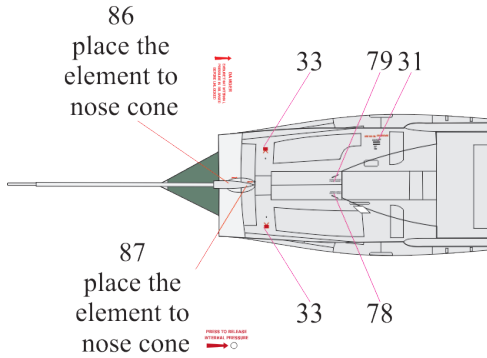

ATTENTION!

All variants have F.6-type wing!!!

ВНИМАНИЕ!

Все варианты имеют крыло по типу F.6

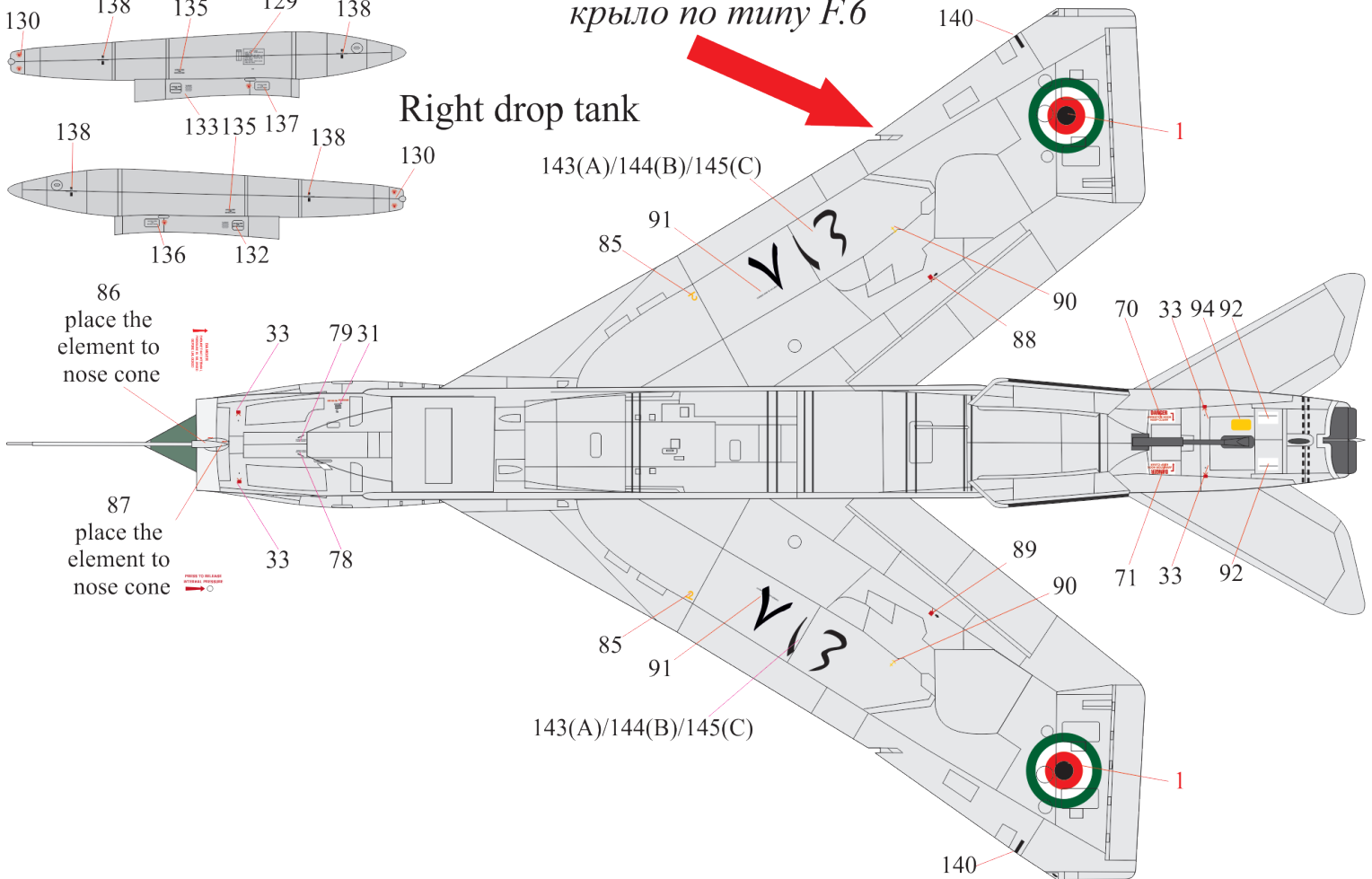

143(A)/144(B)/145(C)