



**DE HAVILLAND**  
**Vampire FB.5**

**HISTORIQUE**

Le Vampire a été le second avion Britannique à réaction à être construit en série dont le prototype vola le 20 septembre 1943. Il équipa la RAF et les Forces aériennes du COMMONWEALTH. Il fut utilisé par diverses Forces aériennes dont la Suisse, le Venezuela, le Liban. La France acheta 67 Vampire Mark V.

**CARACTERISTIQUES**

Envergure ..... 11,58 m  
Longueur ..... 9,37 m  
Hauteur ..... 1,87 m  
Vitesse maxi ..... \*860 km/h

**HISTORY**

The vampire was the second British jet aircraft to be mass-produced and the prototype flew on 20 September 1943. It was supplied to the RAF and to Air Forces of the Commonwealth. It was used by a number of Air Forces of other countries including Switzerland, Venezuela, Lebanon. France bought 67 Vampire Mark V.

**DATA**

Wingspan ..... 11.58 m  
Length ..... 9.37 m  
Height ..... 1.87 m  
Wax speed ..... 860 kph

**HISTORISCHES**

Der Vampire war das zweite britische Düsenflugzeug, das in Serie gebaut wurde. Sein Prototyp flog zum ersten Mal am 20. September 1943. Es rüstete die RAF und die COMMONWEALTH-Luftwaffen eingesetzt, darunter der Schweiz, Venezuelas, Libanos. Frankreich kaufte 67 Vampire Mark V.

**KENNDATEN**

Spannweite ..... 11.58 m  
Länge ..... 9.37 m  
Höhe ..... 1.87 m  
Höchstgeschwindigkeit ..... 860 km/h

**HISTORIAL**

El Vampire fue el segundo avión de reacción Británico construido en Serie. El prototipo realizó su primer vuelo el 20 de Septiembre de 1943. Equipó la RAF y las Fuerzas Aereas del COMMONWEALTH. Fue utilizado por diferentes Fuerzas Aéreas, entre las cuales Suiza, Venezuela, el Libano. Francia compró 67 Vampire Mark V.

**CARACTERISTICAS**

Envergadura ..... 11,58 m  
Longitud ..... 9,37 m  
Altura ..... 1,87 m  
Velocidad máxima ..... 860 km/h

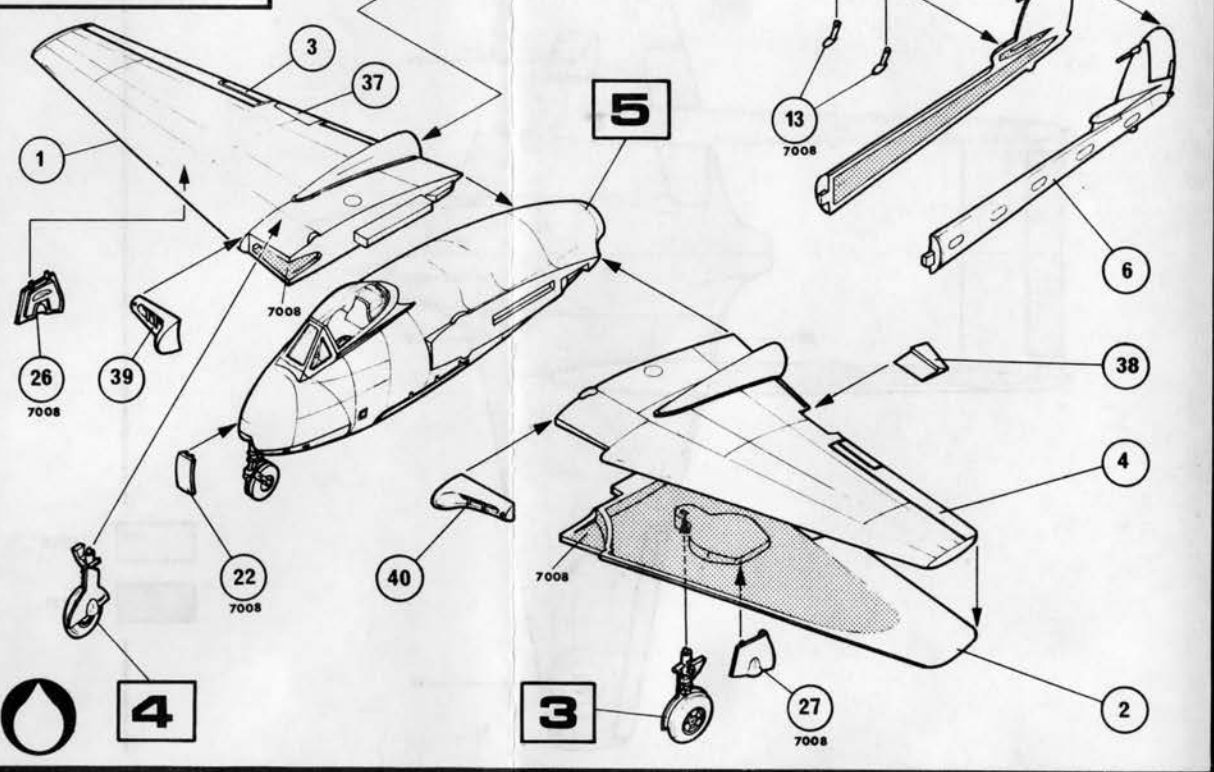
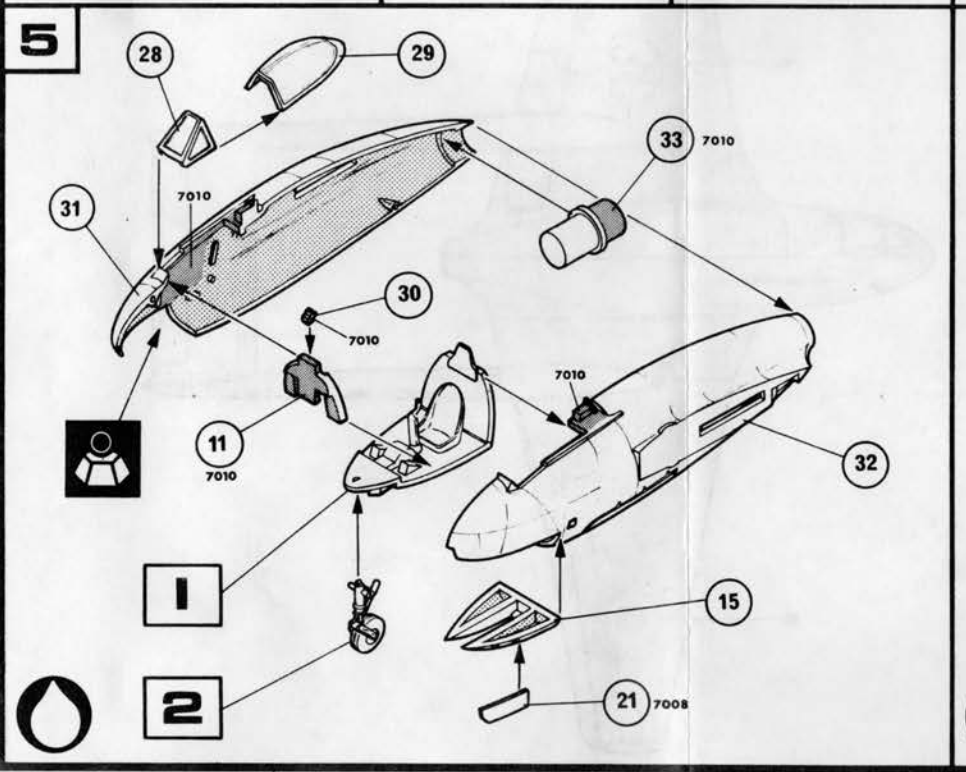
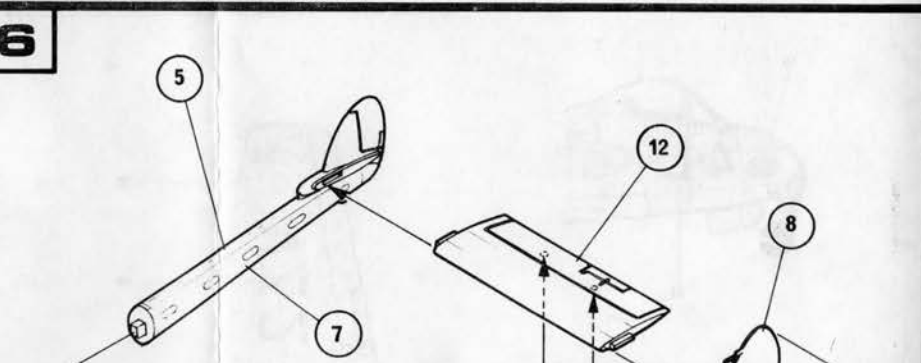
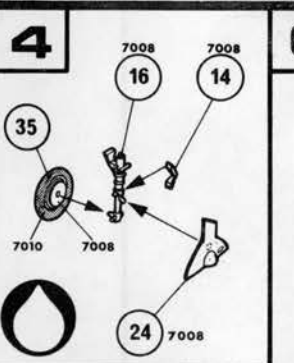
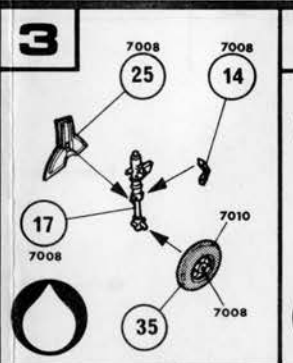
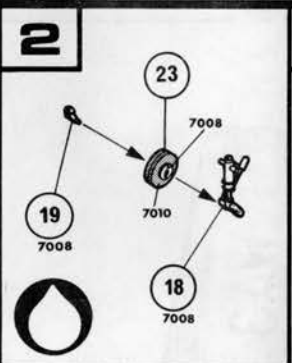
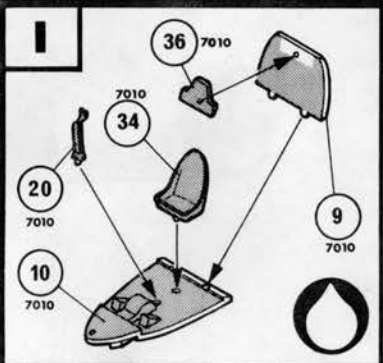
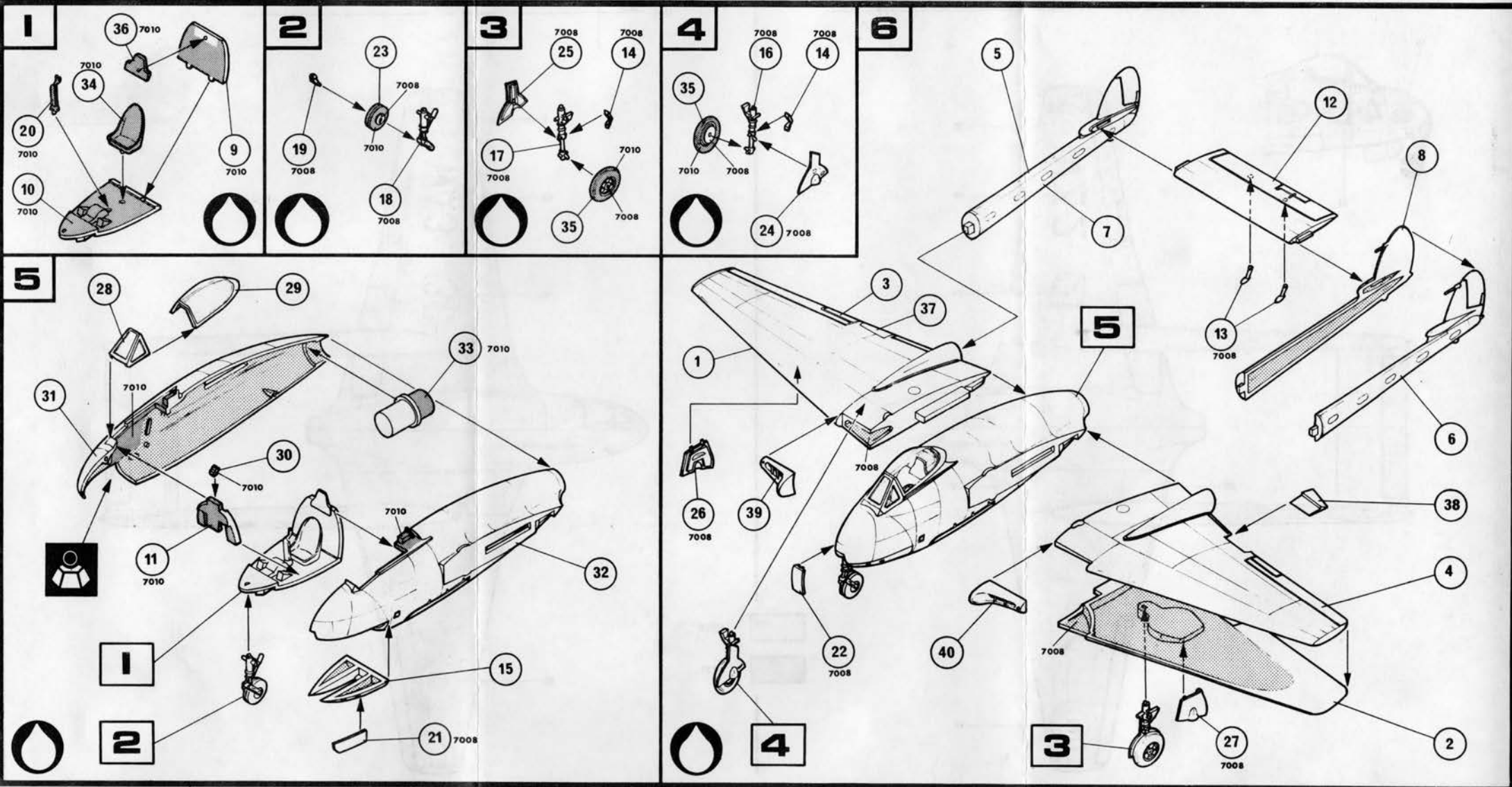

FRANCE . FB.5 Vampire 4<sup>e</sup>E.C. 1/4 Lafayette 1951



G.B. FB.5 Vampire 112 Squadron 2<sup>nd</sup> TAF

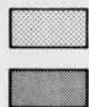
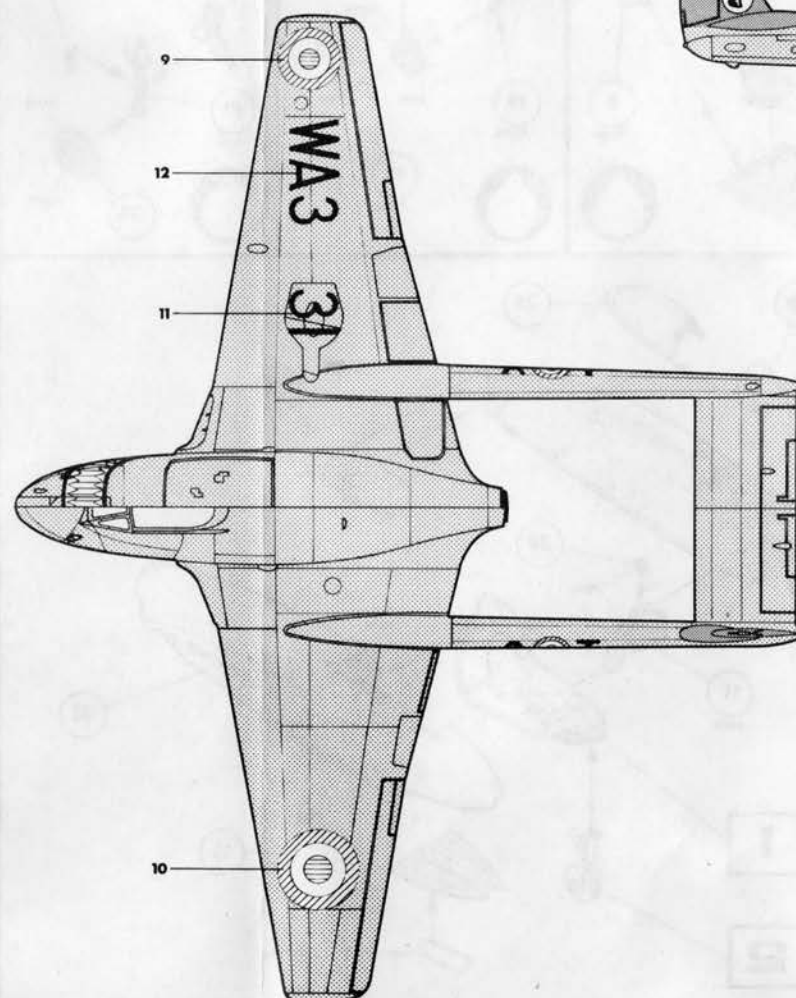
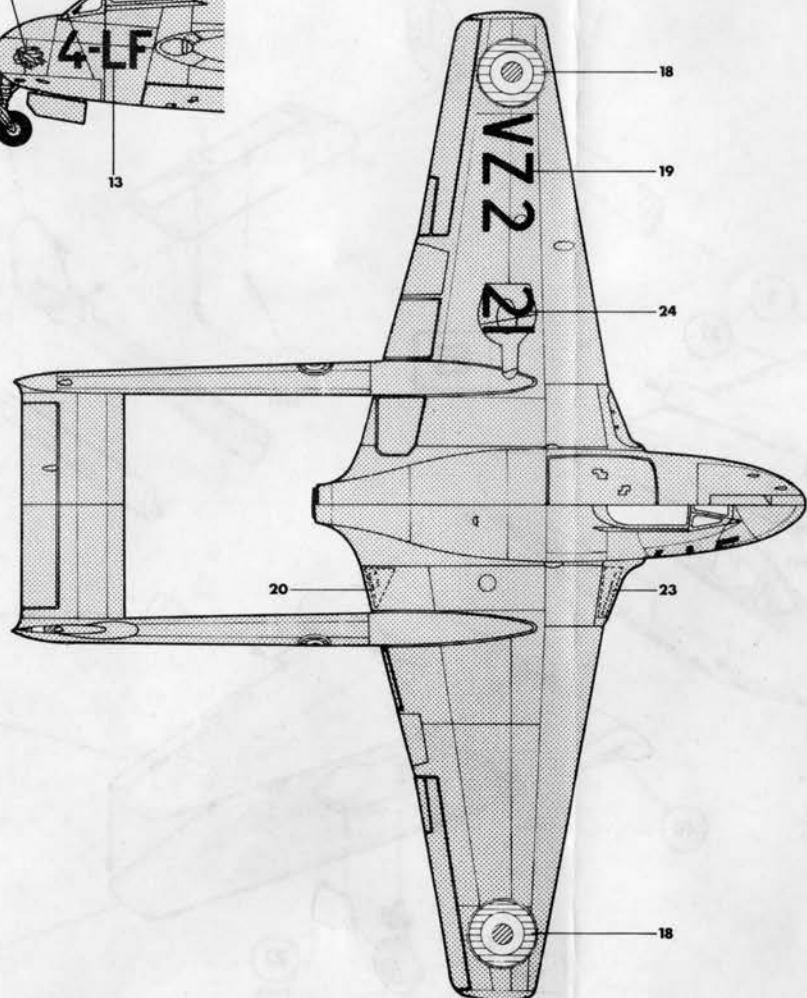
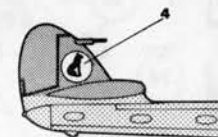
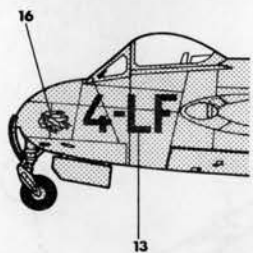
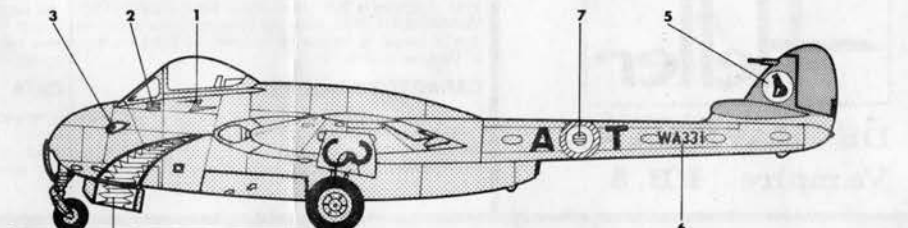
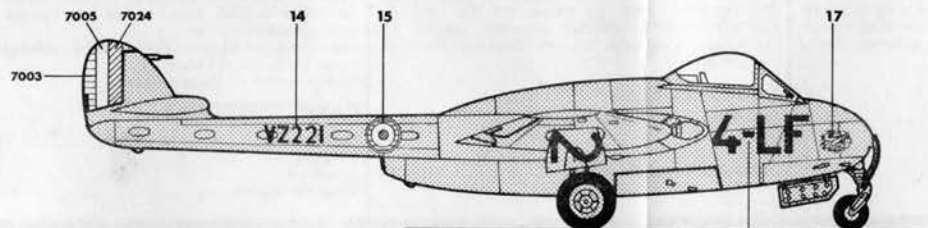

7008

7021