

SD. KFZ. 10 AND M18



KIT. 5008 1/35 th Scale - Echelle 1/35 ème

MADE IN ITALY



Il veicolo semicingolato da una tonnellata, Demag D7, sviluppato dalla ditta omonima, entrò ufficialmente in servizio nell'esercito tedesco nel 1939, dapprima destinato al traino dei pezzi d'artiglieria leggera, più tardi, grazie alle sue doti di affidabilità e robustezza, trasformato, con opportune modifiche, in semovente dotato di armi anti-carro o anti-aerea (Pak 40, Flak 30/38). Prodotto sino al 1944 in più di 17.000 esemplari, ebbe larghissima diffusione, e dal suo telaio prese vita il noto Sd. Kfz. 250, capostipite di una lunga serie di sottoversioni.

The 1 ton half-track, Demag D7, manufactured by the company of the same name, officially took service in the German army in 1939, first to tow light artillery pieces and later, because of its reliability and solidness, it was adapted to become a self-propelled vehicle with antitank and anti-aircraft guns (Pak 40, Flak 30/38). Over 17.000 were manufactured, it was very widely used and its chassis served for the well known Sd. Kfz. 250, the first of a long series of subversions.

Le véhicule semi-chenillé d'une tonne, Demag D7, construit par la maison portant le même nom, entra officiellement en service dans l'armée allemande en 1939. Il était destiné au début à remorquer des pièces d'artillerie légère. Par la suite, du fait de ses qualités de fiabilité et de solidité, il fut, après qu'on y ait apporté les modifications nécessaires, transformé en automoteur équipé d'armes anti-

char ou antiaériennes (Pak 40, Flak 30/38). Produit jusqu'en 1944, plus de 17.000 unités, il fut l'objet d'une très large diffusion. C'est de son châssis que découle le très connu Sd. Kfz. 250, chef de file d'une très longue série de sous-versions.

Das Eine-Tonnen-Sonderkraftfahrzeug Demag D7, von der gleichnamigen Firma konstruiert, trat 1939 offiziell in den Dienst des deutschen Heers. Anfänglich als Schlepperfahrzeug fuer leichte Artillerieschütze verwendet, wurde es später - Dank seiner aussergewöhnlich guten Eigenschaften und seiner Widerstandsfähigkeit - zweckmässig in Selbstfahrlafette fuer Panzer- und Luftabwehrgeschütze (Pak 40 Flak 30/38) verändert. Bis 1944 wurden 17.000 dieser weitverbreiteten Exemplare hergestellt. Aus seinem Chassis wurde das bekannte Sd. Kfz. 250 geboren, Stammvater einer langen Serie anderer Fahrzeuge.

El vehículo de orugas de una tonelada Demag D7, desarrollado por la empresa que lleva el mismo nombre, entro oficialmente al servicio del ejército alemán en 1939. Primero fue destinado al arrastre de las artillerías livianas, luego, gracias a sus características de confiabilidad y fuerza, fue transformado oportunamente en semovente con armas anticarro e antiaéreas (Pak 40, Flak 30/38). Fue producido hasta 1944 en más de 17.000 ejemplares; fue ampliamente difundido y de su chasis nació el conocido Sd. Kfz. 250, la primera de una larga serie de subversiones.

1

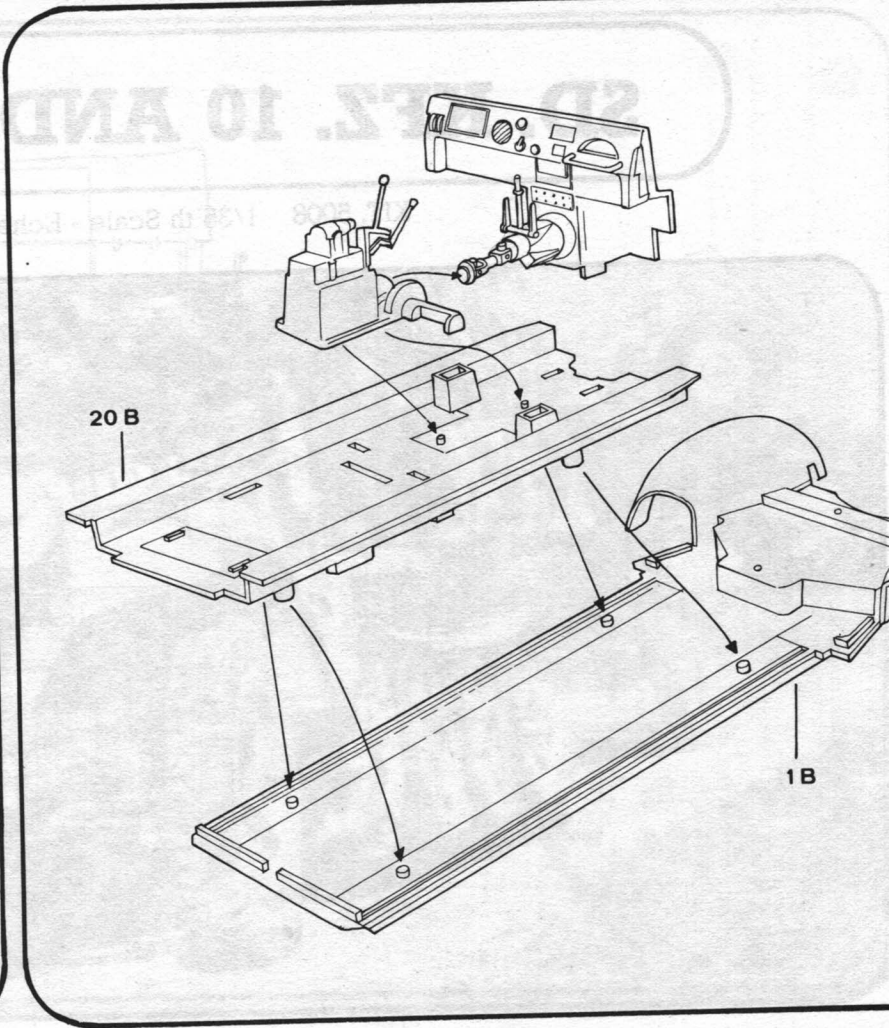
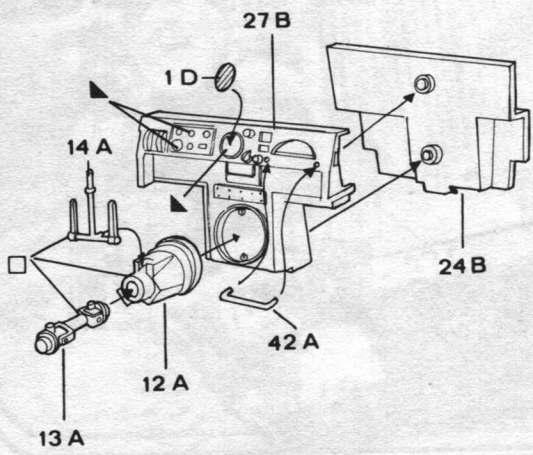
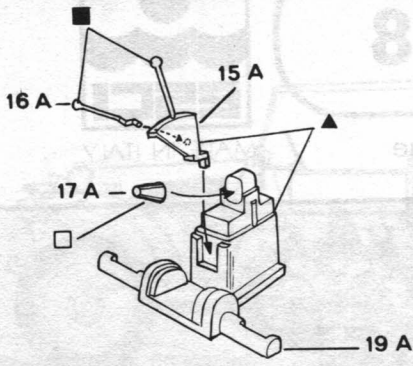

5

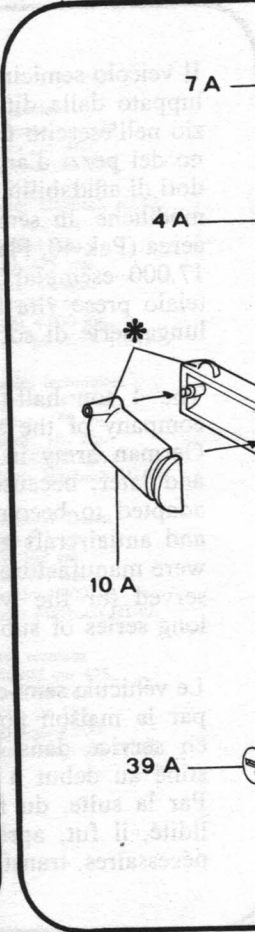
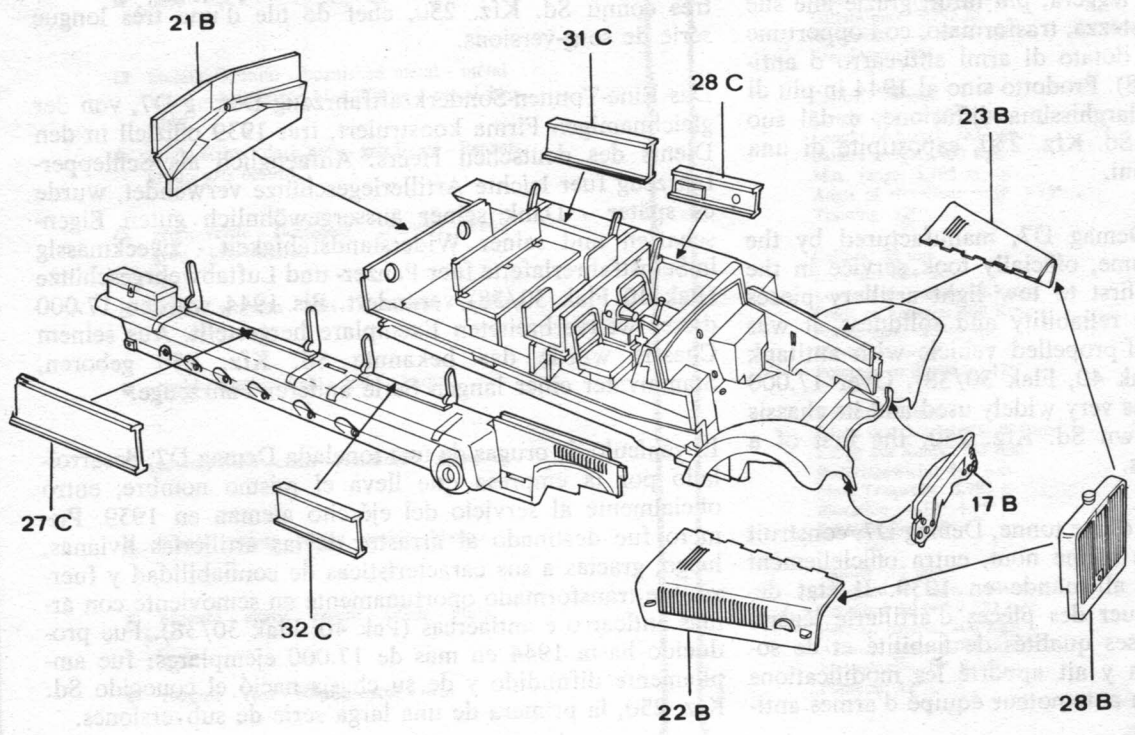

2

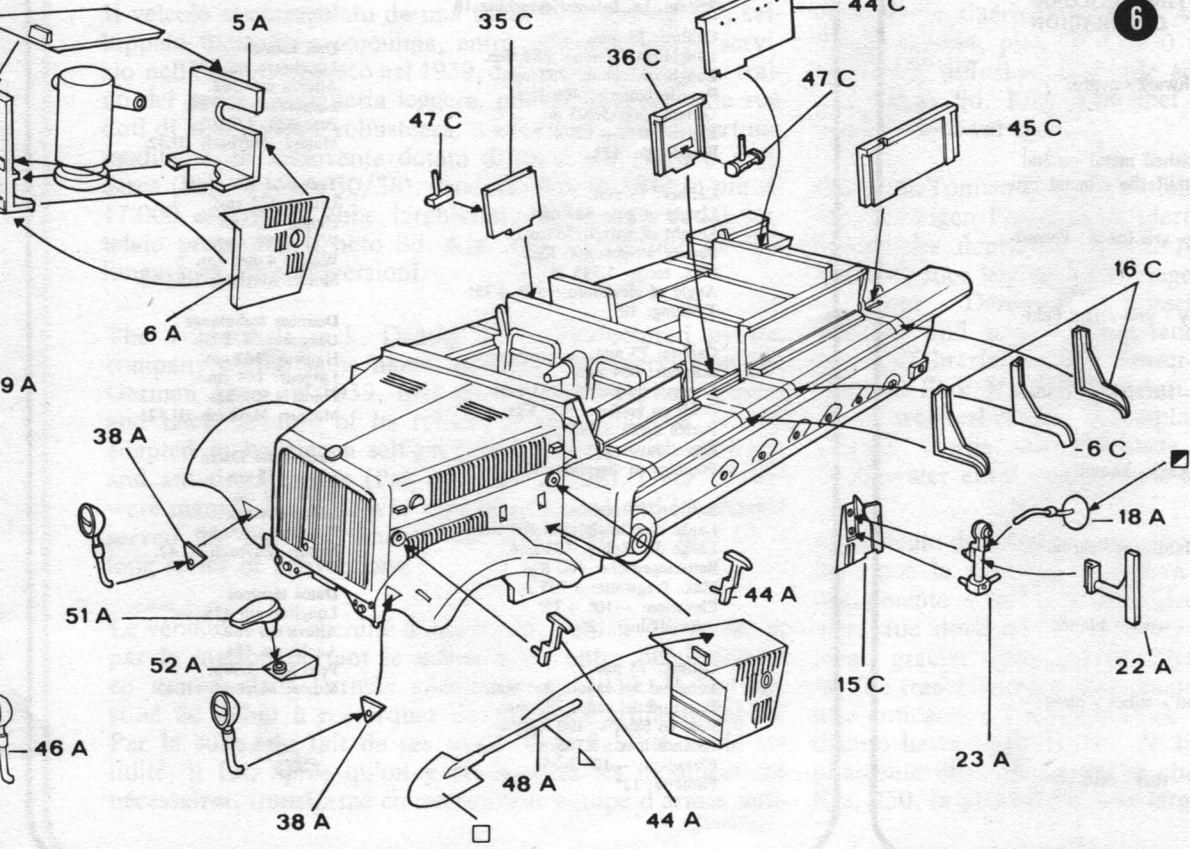
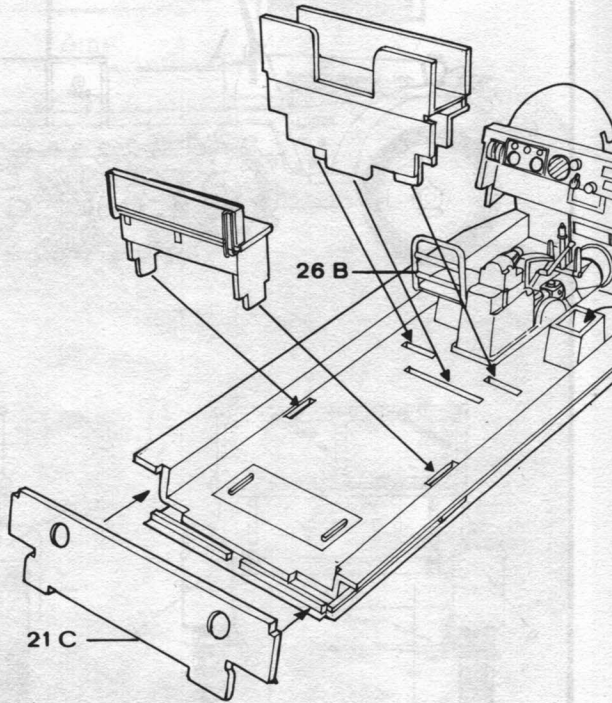
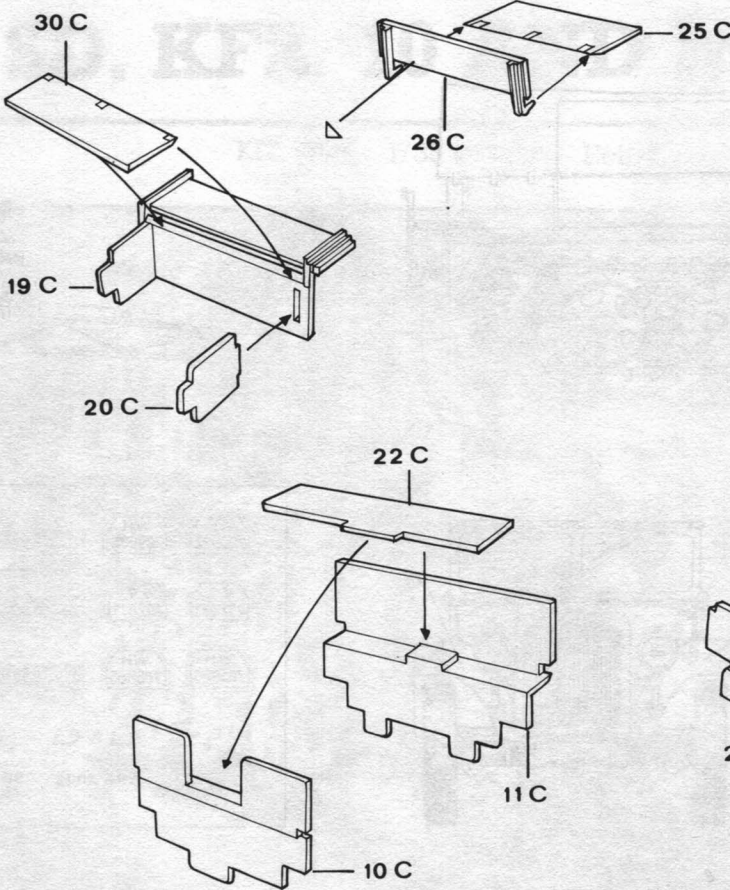

6

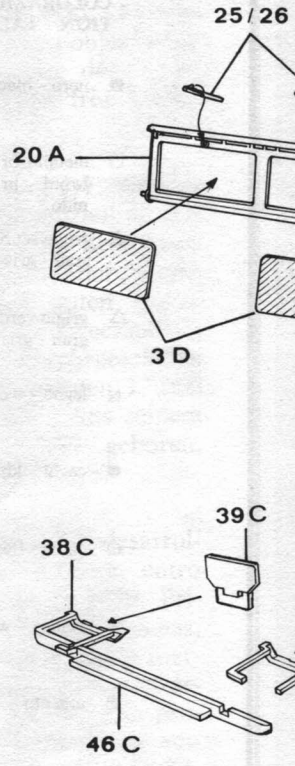

3

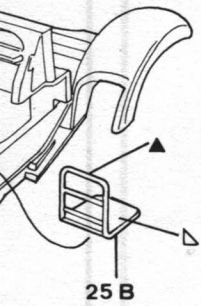

4

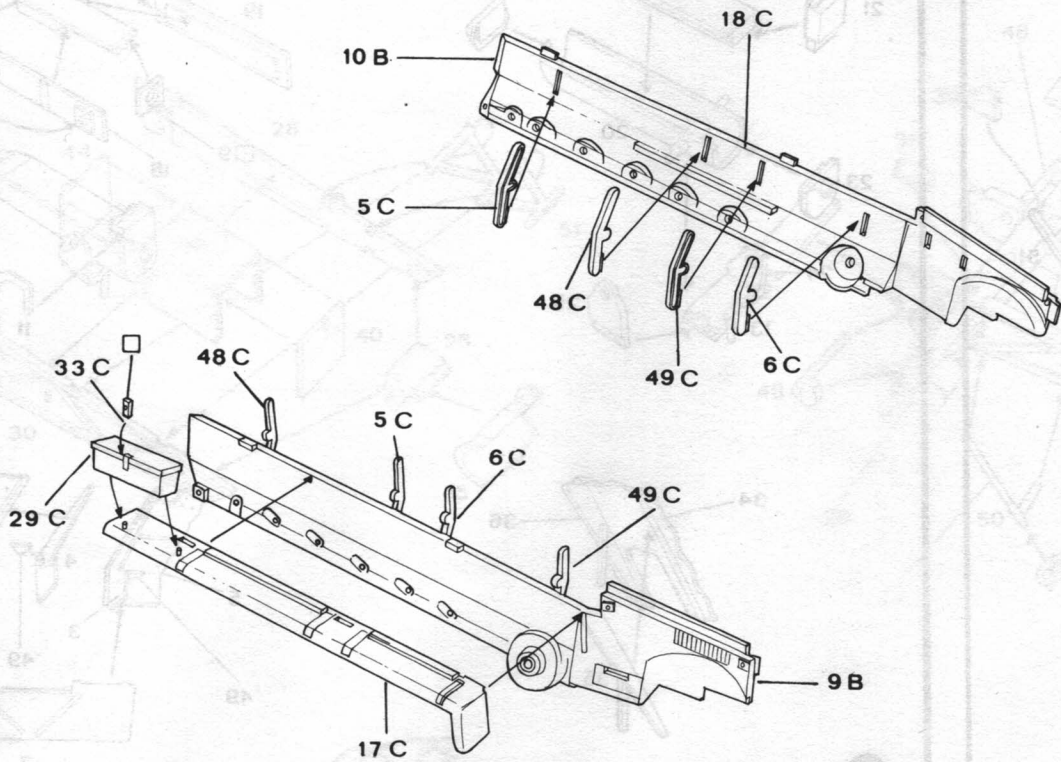

7

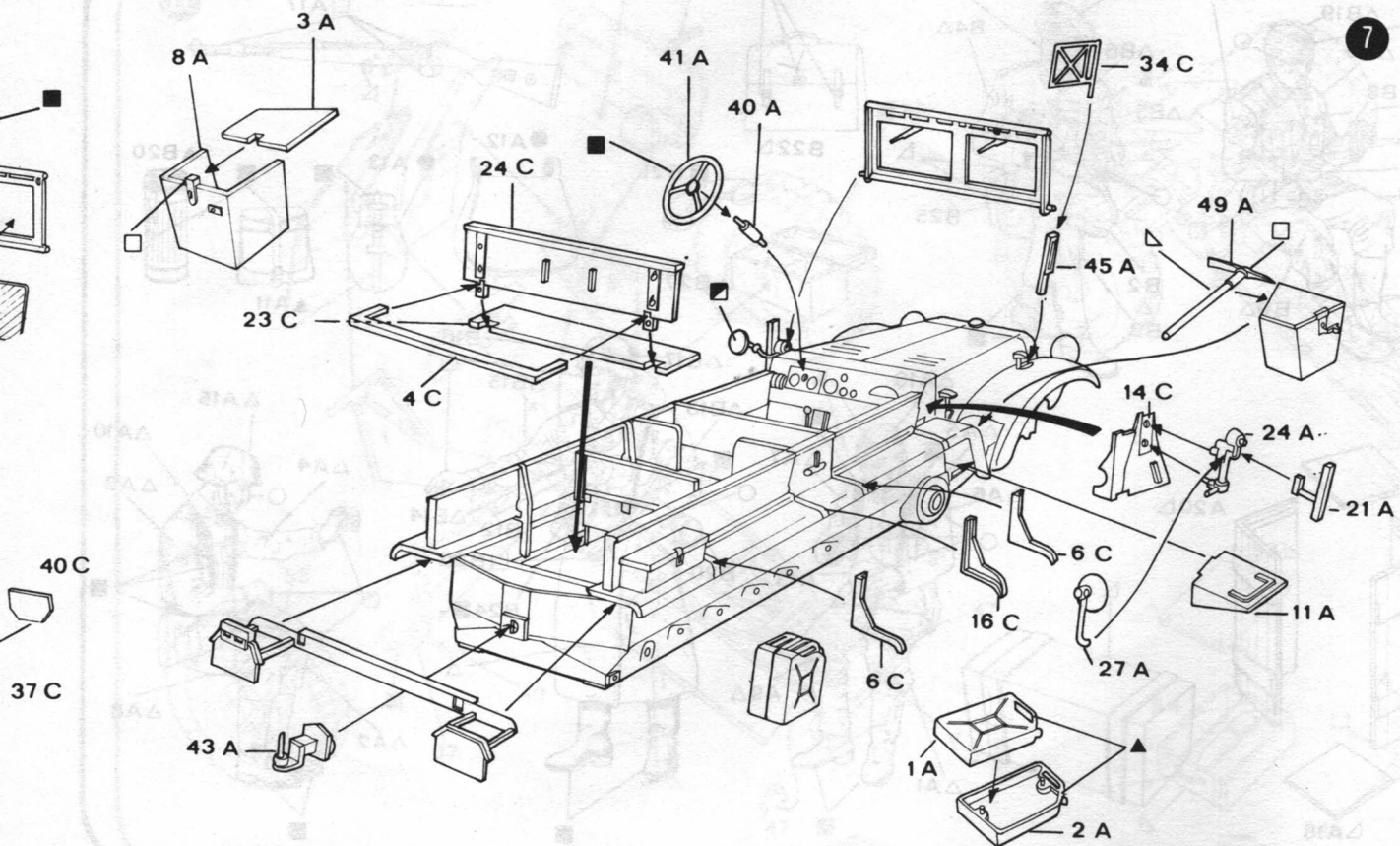

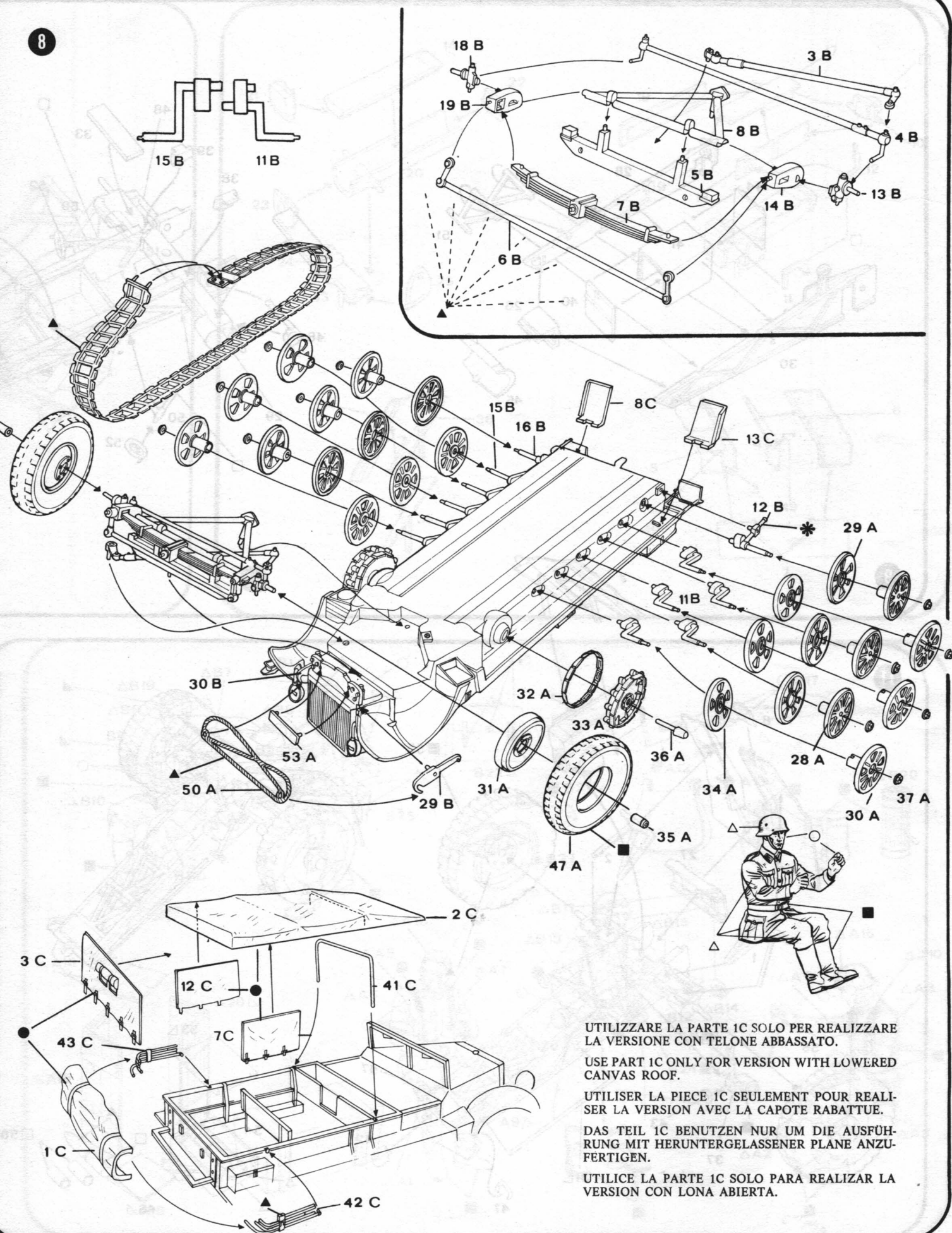

UTILIZZARE LA PARTE 1C SOLO PER REALIZZARE LA VERSIONE CON TELONE ABBASSATO.

USE PART 1C ONLY FOR VERSION WITH LOWERED CANVAS ROOF.

UTILISER LA PIECE 1C SEULEMENT POUR REALISER LA VERSION AVEC LA CAPOTE RABATTUE.

DAS TEIL 1C BENUTZEN NUR UM DIE AUSFÜHRUNG MIT HERUNTERGELASSENER PLANE ANZUFERTIGEN.

UTILICE LA PARTE 1C SOLO PARA REALIZAR LA VERSION CON LONA ABIERTA.

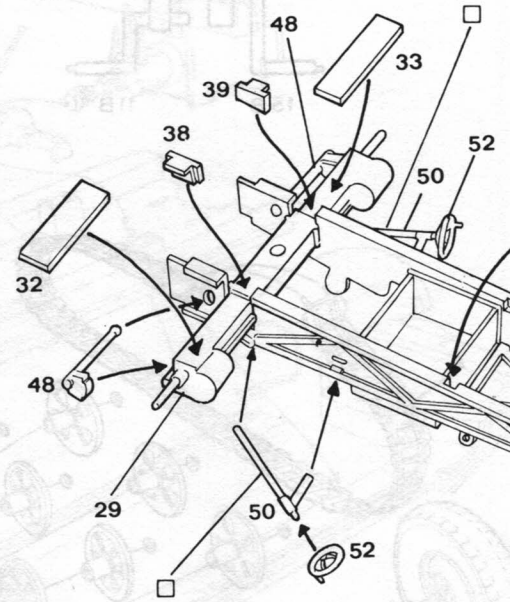
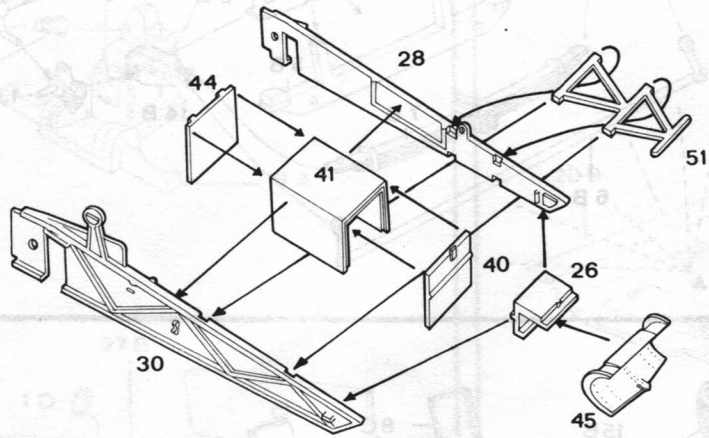

9



11

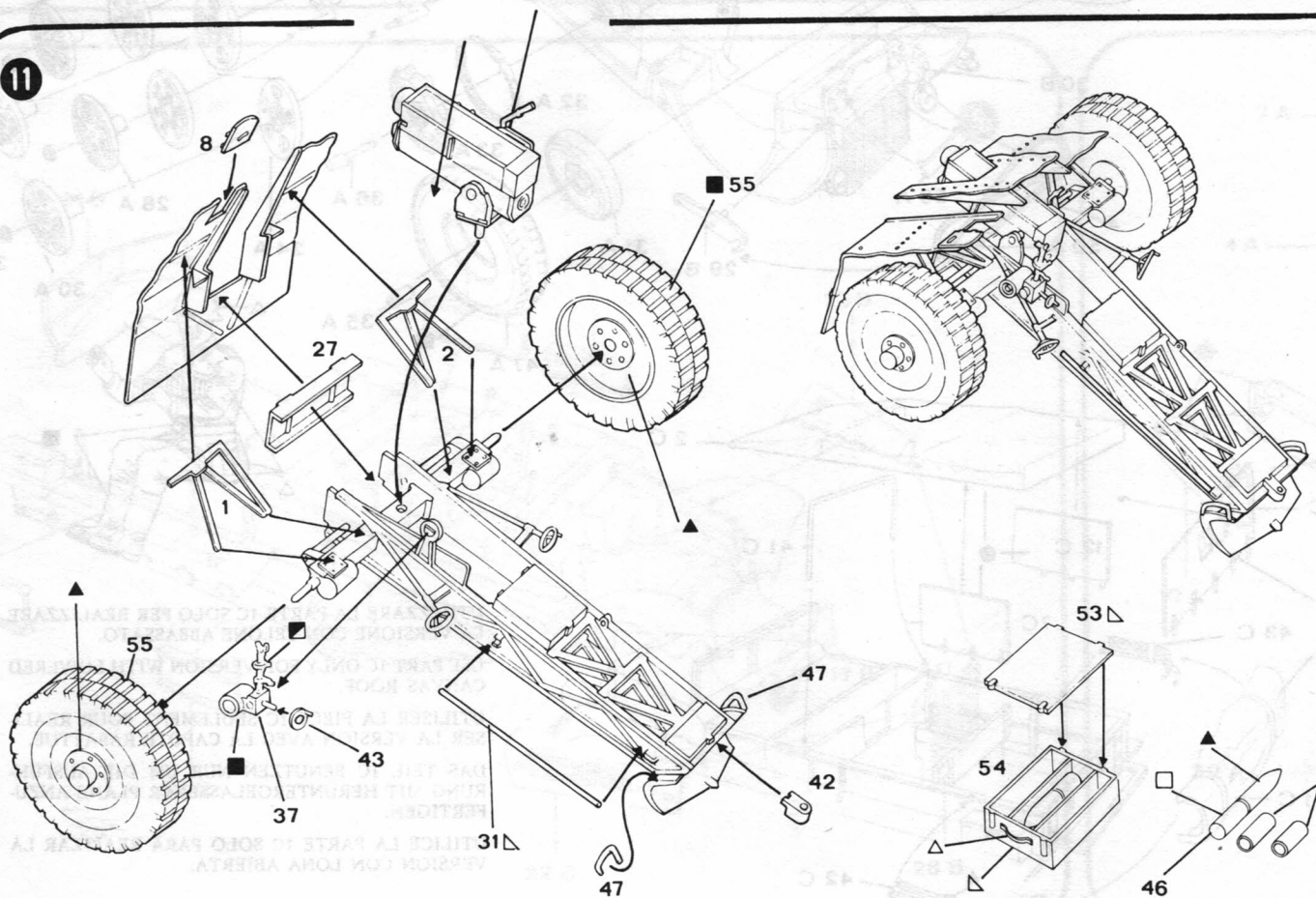

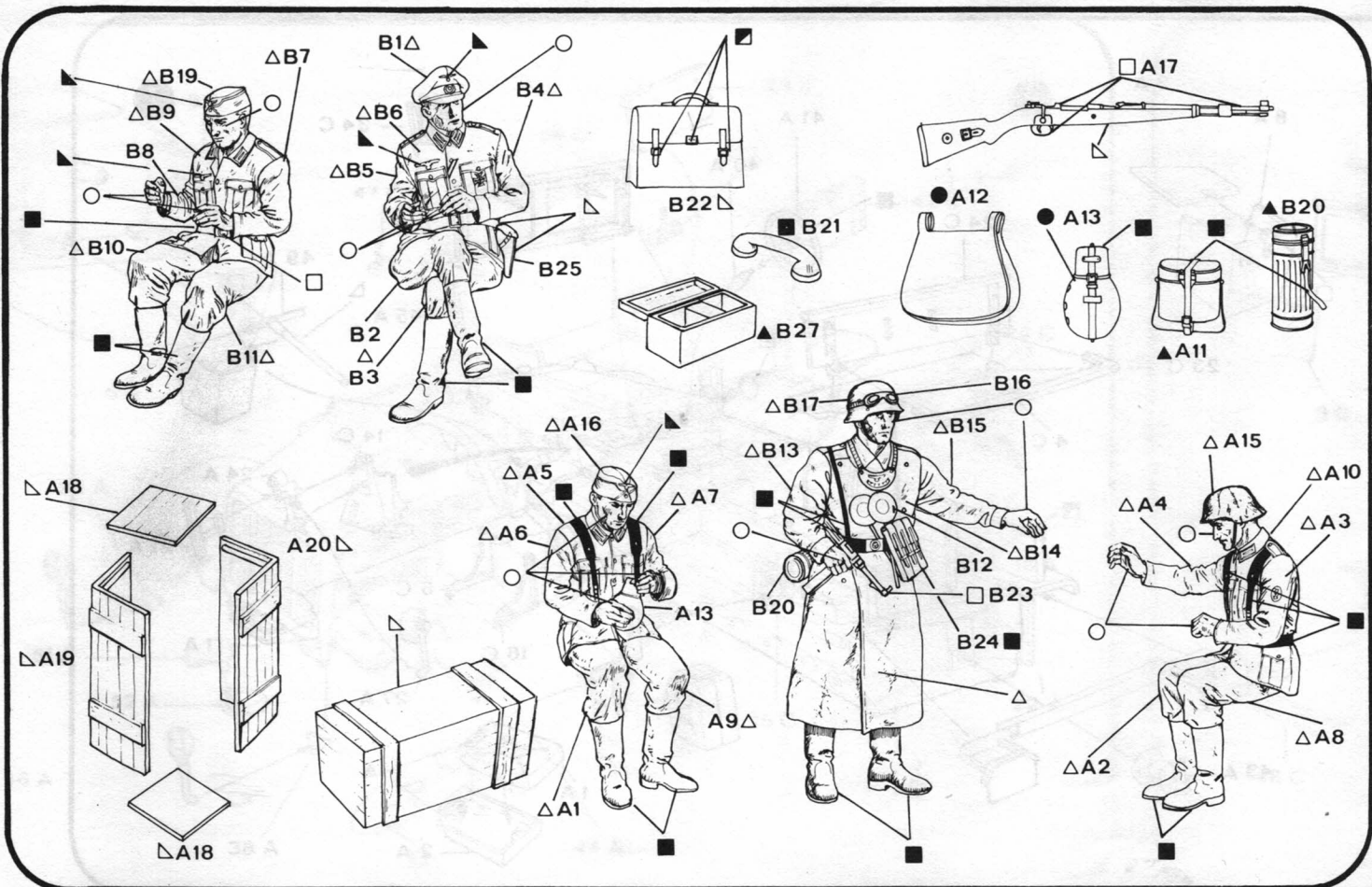
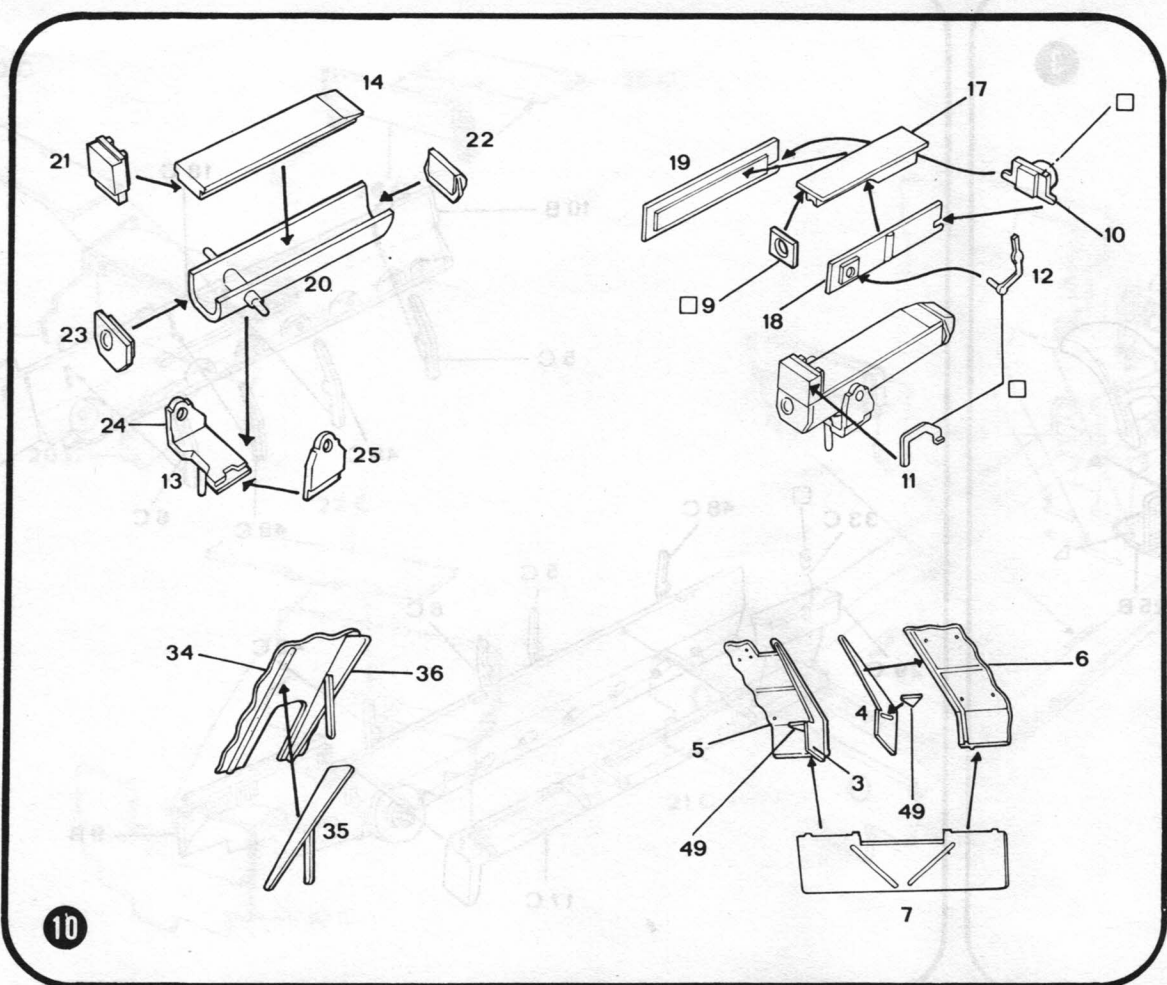
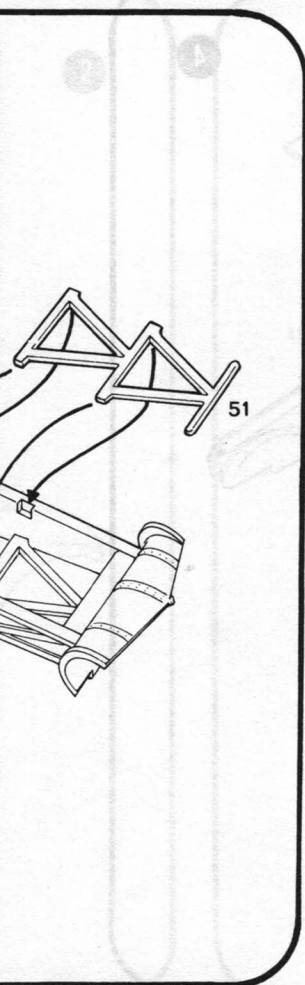

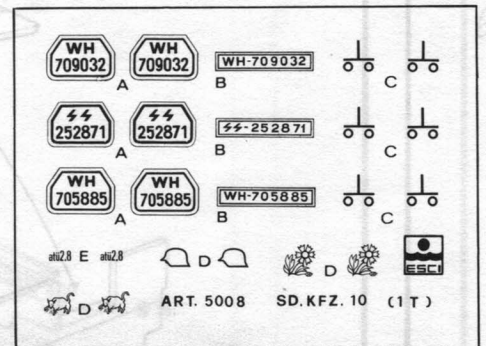
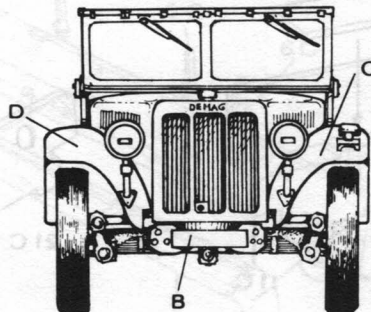
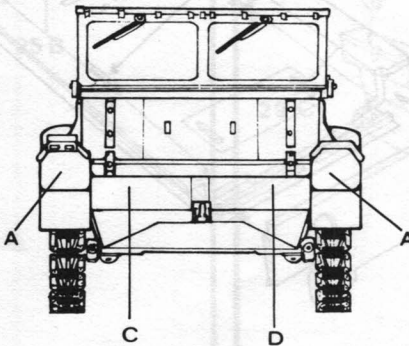
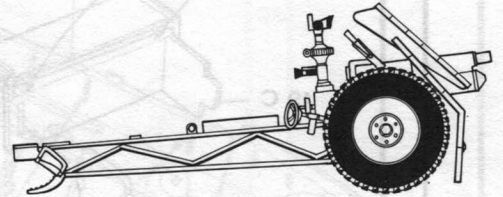
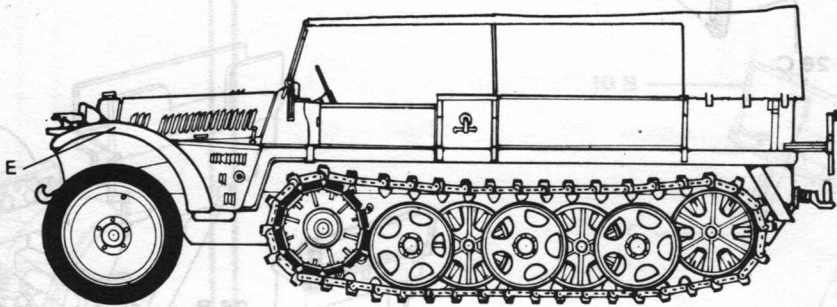

COLORAZIONE - PAINTING - COLORATION - FAERBUNGEN - COLORACION

- nero - black - noir - schwarz - negro.
- metallo brunito - burnished metal - métal bruni - brüniertér Metallfarbe - metal brunito.
- ▲ grigio scuro - dark grey - gris foncé - Panzergrau - gris oscuro.
- △ grigio-verde - field-grey - gris-vert - Feldgrau - gris oscuro.
- ▷ legno - wooden - bois - Holzfarbe - madera.
- cachi - khaki - kaki - kaki - kaqui.
- carne - flesh - chair - Hautfarbe - carne.
- ▲ bianco - white - blanc - weiss - blanco
- argento - silver - argent - silber - plata
- * ruggine - rust - rouille - rost - orin

7.5 cm. Le. Infanteriegeschütz 18

Calibro: 75 mm.
Lunghezza cannone: 884 mm.
Lunghezza canna: 783 mm.
Peso in batteria: 400 Kgs.
Gittata max: 3.795 m.
Elevazione: -10° + 75°
Brandeggio: 12°.

Caliber: 75 mm.
Length of gun: 884 mm.
Length of barrel: 783 mm.
Battery weight: 400 Kgs.
Max. range: 3.795 m.
Angle of elevation: -10° + 75°
Training: 12°

Calibre: 75 mm.
Longeur: 884 mm.
Longeur du canon: 783 mm.
Poids en batterie: 400 Kgs.
Portée max.: 3.795 m.
Elevation: -10° + 75°
Pointage en direction: 12°

Kaliber: 75 mm.
Länge des Geschützes: 884 mm.
Länge des Rohrs: 783 mm.
Batteriegewicht: 400 Kgs.
Max. Tragweite: 3.795 m.
Elevation: -10° + 75°
Schwenkung: 12°

Calibre: 75 mm.
Longitud del cañon: 884 mm.
Longitud del caño: 783 mm.
Peso en batería: 400 Kgs.
Alcance max.: 3.795 m.
Elevacion: -10° + 75°
Puntería: 12°

Dati tecnici

Lunghezza cm. 475.
Altezza cm. 162.
Larghezza cm. 184.
Peso Kgs. 4.900.
Motore: Maybach HL42.

Technical data

Length 475 cms.
Height 162 cms.
Width 184 cms.
Weight 4.900 kgs.
Motor: Maybach HL42.

Données techniques

Longueur: 475 cm.
Hauteur: 162 cm.
Largeur: 184 cm.
Poids: 4.900 kgs.
Moteur: Maybach HL42.

Technische Daten

Länge 475 cm.
Höhe 162 cm.
Breite 184 cm.
Gewicht 4.900 kg.
Motor: Maybach HL42.

Datos técnicos

Longitud cm 475.
Altura cm 162.
Ancho cm 184.
Peso Kgs. 4.900.
Motor: Maybach HL42.