

KIT 5225

1/48 SCALE MASSTAB 1:48 ESCALA 1/48

SCHAAL 1:48 1/48 ECHELLE SKALA 1/48 SCALA 1/48

MONOGRAM MODELS, INC. Des Plaines, IL Copyright ©1990. All rights reserved. Made in U.S.A.

5225 M 0200

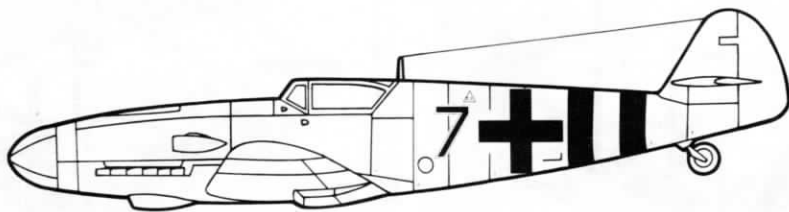

In the summer of 1934, Professor Willy Messerschmitt, Director of Design with a German aircraft manufacturing firm in Augsburg, was requested by his government to develop and build a more effective fighter plane for the Luftwaffe.

It was decided to make the smallest possible airframe to accommodate the most powerful engine available, the 695 h.p. Rolls-Royce Kestrel. In September 1935, the first prototype successfully completed initial flight trials. The Me-109 was continually developed and was credited

with re-establishing German aviation prestige by winning the International Flying Contest at Zurich in 1937.

In its early stages, the Me-109 appeared to have many shortcomings. Despite these problems, the new fighter was developed into a highly successful combat plane and earned the distinction of being produced in larger numbers than any other combat aircraft of World War Two. By prevailing standards it handled well, possessed excellent low-speed control, and was superior in climb-rate and ceiling.

READ THIS BEFORE YOU BEGIN

- Study the assembly drawings.
- Each plastic part is identified by a number.
- Check the fit of each piece before cementing in place.
- Do not use too much cement to join parts.
- Use only cement for polystyrene plastic.
- Model may be painted to match photos on box.
- Allow paint to dry thoroughly before handling parts.
- Scrape paint from areas to be cemented.
- For better paint and decal adhesion, wash the plastic parts in a mild detergent solution. Rinse and let air dry.

ALLGEMEINE HINWEISE

- Die Anordnung der Bauteile ist aus den Zeichnungen der Anleitung ersichtlich.
- Jedes Plastikteil ist durch eine Nummer gekennzeichnet.
- Die Teile vor dem Verkleben ungeleimt zusammenhalten, um ihren Passitz zu prüfen.
- Klebstoff nicht zu dick auftragen.
- Nur Modellbaukleber für Polystyrol verwenden.
- Man kann das Modell nach den Fotos auf der schachtel anstreichen.
- Bemalte Teile vor der Weiterverwendung gut trocknen lassen.
- Die Farbe muss von allen späteren Klebestellen abgeschabt werden.
- Damit die Farbe und die Abziehbilder besser kleben, sind die Plastikteile in einer milden Seifenlauge zu waschen. Dann abspülen und an der Luft trocknen lassen.

LEA ESTO ANTES DE EMPEZAR

- Estudie los dibujos de ensamblaje.
- Cada pieza de plástico se identifica por un número.
- Verifique que cada pieza encaje bien antes de pegar en posición.

- No use demasiado pegamento para unir las piezas.
- Use únicamente pegamento para plástico de poliestireno.
- El modelo puede pintarse de acuerdo con las fotografías de la caja.
- Permita que se seque la pintura completamente antes de locar las piezas.
- Raspe la pintura de las superficies que serán pegadas.
- Para una mejor fijación de la pintura y de las calcomanías, lávese las piezas plásticas en una solución de detergente suave. Enjuáguese y déjense secar al aire.

LEES DIT ALVORENS TE BEGINNEN

- Bestudeer de bouwtekening.
- Elk plastic onderdeel is genummerd.
- Controleer de passing van elk deel vóór het lijmen.
- Gebruik niet te veel lijm.
- Aléén lijm voor polystyreen plastic gebruiken.
- Men kan de verf van de te verwerken delen steeds goed drogen.
- Verwijder de verf van te lijmen oppervlakken.
- Zodat de verf en etiketten beter zullen plakken, was de plasticke delen in een milde seep oplossing. Spoel en laat in de openlucht opdrogen.

LISEZ CE QUI SUIT AVANT DE COMMENCER LE MONTAGE

- Etudiez les schémas d'assemblage.
- Chaque pièce plastique porte un numéro d'identification.
- Contrôlez que chaque pièce soit bien conforme avant de la coller à sa place.
- N'utilisez pas trop de colle pour réunir les pièces.
- Utilisez uniquement une colle spéciale pour polystyrène.
- Le modèle peut être peint conformément aux photos sur la boîte.

- Laissez sécher la peinture complètement, avant de manipuler les pièces.
- Grattez la peinture sur les surfaces devant être collées.
- Pour assurer la meilleure adhésion possible de la peinture et des décalcomanies, lavez les pièces de plastique avec une légère solution savonneuse. Rincer et laisser sécher à l'air.

LAS DET HAR INNAN DU BORJAR BYGGA

- Studera monteringskisserna.
- Alla plastdelar har identifikationsnummer.
- Kolla noga att delarna passar före limningen.
- Stryk inte för mycket lim på delarna.
- Använd endast lim för polystyren-plast.
- Modellen kan målas enligt foton på kantungerna.
- Låt färgen torka ordentligt före limningen.
- Skrapa bort färgen på de ytor som ska limmas.
- För bättre vidhäftning av färg och dekalmarken rengör plastdelarna i en mild tvättmedelslösning. Skölj och låt lufttorka.

DA LEGGERE PRIMA DI INIZIARE

- Studia le illustrazioni.
- Ogni pezzo è identificato da un numero.
- Controlla l'incastro di ogni pezzo prima di incollarlo.
- Non usare troppa colla per unire i pezzi.
- Adopera solamente colla per materie plastiche.
- Il modello si può dipingere seguendo le fotografie sulla scatola.
- Aspetta che la vernice sia completamente asciutta prima di maneggiare le parti.
- Asporta la vernice dai punti dove applicherai la colla.
- Per una migliore aderenza di vernice e decalcomanie, lavare le parti in plastica in soluzione detergente non abrasiva. Risciacquare e lasciare asciugare all'aria.



DO NOT CEMENT
NICHT KLEBEN
NO USE PEGAMENTO
NET LIJMEN
NE PAS COLLER
LIMMAS INTE
NON INCOLLARE



DECAL (DIP IN WATER)
ARZIEHBILD
DECALCOMANIA (MOJE CON AGUA)
TRANSFERS (IN WATER DOPPEN)
DECALCOMANIE (A PLONGER DANS L'EAU)
DEKAL (DÖPPAS I VATTEN)
DECALCOMANIA (IMMERGI IN ACQUA)

A	BLACK GREEN	SCHWARZGRÜN	VERDE NEGRUZZO	ZWART-GROEN	VERT TRES FONCE	SVARTGRÖN	VERDE QUASI NERO
B	BROWN	BRAUN	MARRON	BRUIN	BRUN	BRUN	MARRONE
C	DARK GREEN	DUNKELGRÜN	VERDE OSCURO	DONKERGRÖEN	VERT FONCE	MÖRKGRÖN	VERDE SCURO
D	LIGHT BLUE	HELLBLAU	AZUL CLARO	LICHTBLAUW	BLEU CLAIR	LJUSBLÅ	AZZURRO CHIARO
E	DARK GRAY	DUNKELGRAU	GRIS OSCURO	DONKER GRIJS	GRIS FONCE	MÖRKGRÅ	GRIGIO SCURO
F	ALUMINIUM	ALUMINIUMFARBEN	ALUMINIO	ALUMINIUMKLEURIG	ALUMINIUM	ALUMINIUMFÄRGAD	ALLUMINIO
G	WHITE	WEISS	BLANCO	WIT	BLANC	VIT	BIANCO
H	FLAT BLACK	GLANZLOSES SCHWARZ	NEGRO APAGADO	GLANSLÖDS ZWART	NOIR TERNE	MATTSVART	NERO OPACO

1

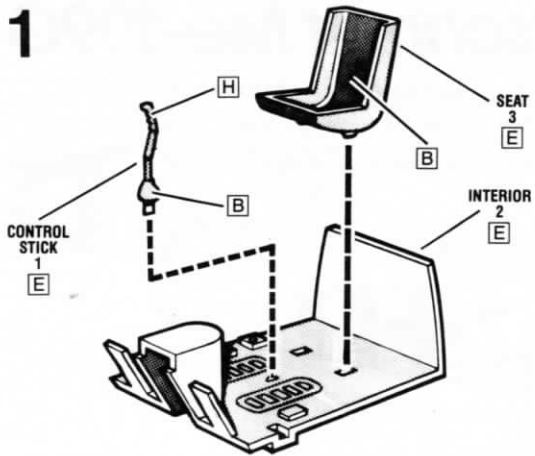

2

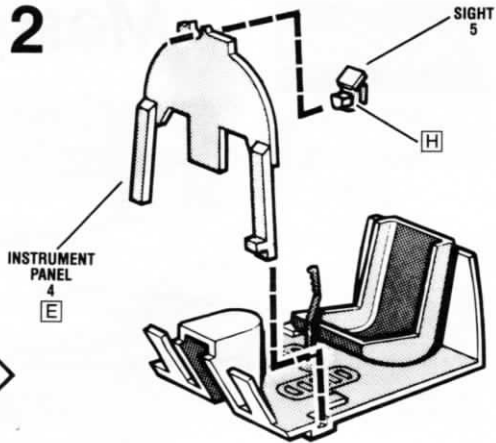

3

FUSELAGE
HALF
7

E

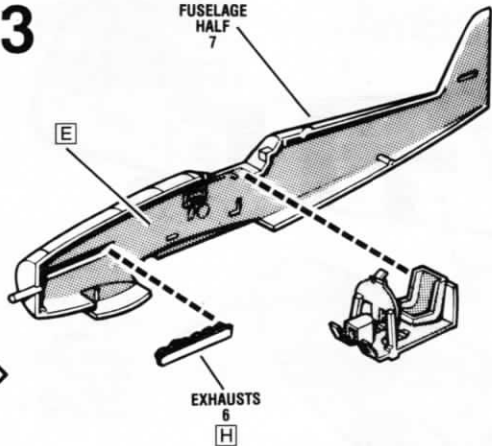

EXHAUSTS
6
H

4

EXHAUSTS
9
H

AIR
INTAKE
8
H

FUSELAGE
HALF
10
E

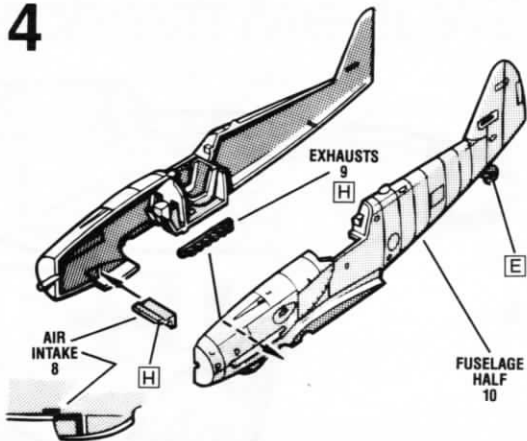

5

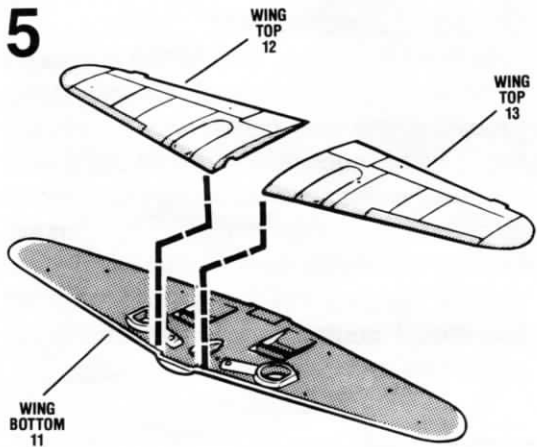

6

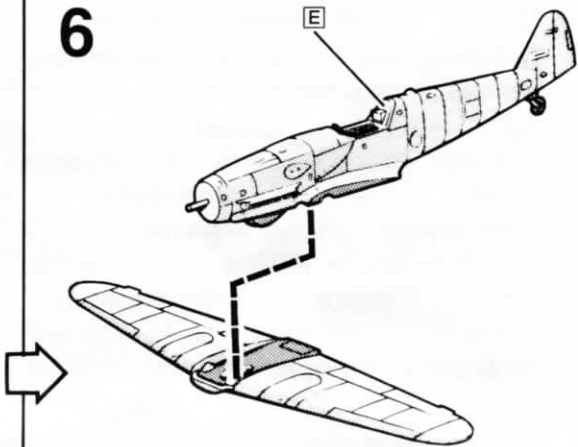

7

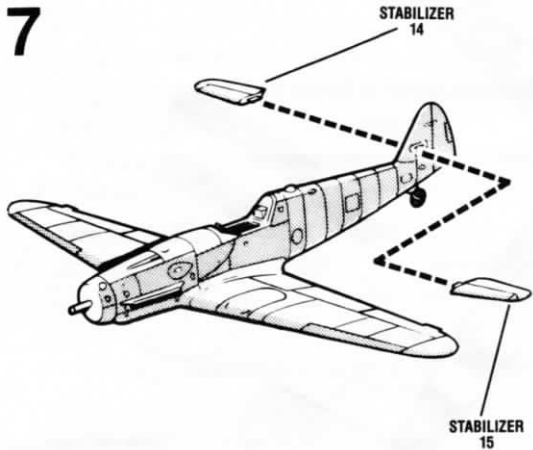

8

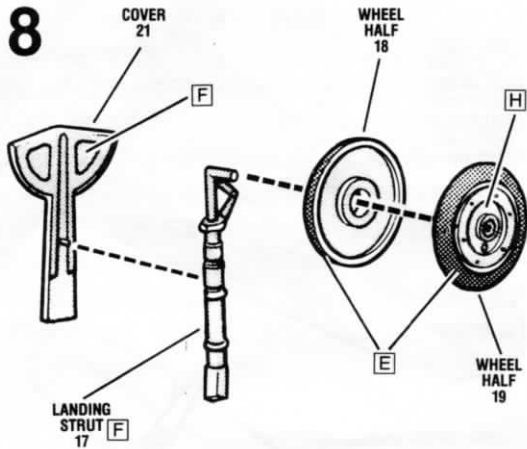

9

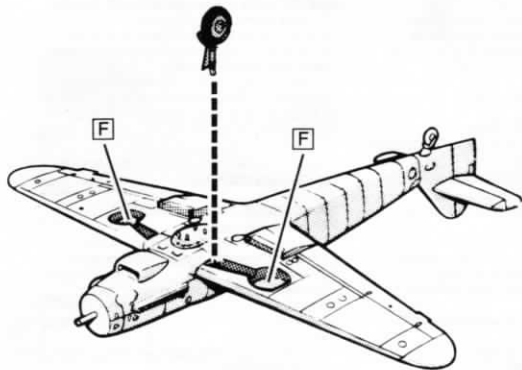

10

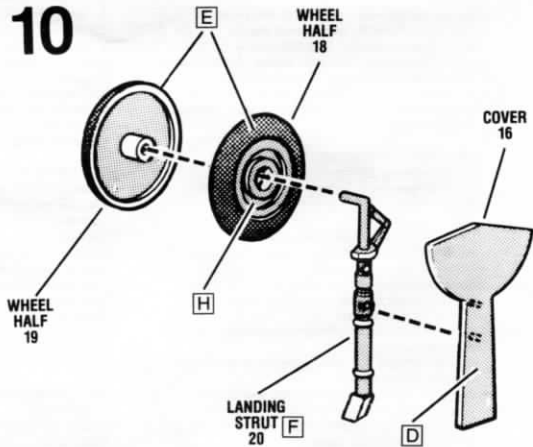

11

TANK
HALF
22
D

TANK
HALF
23
D

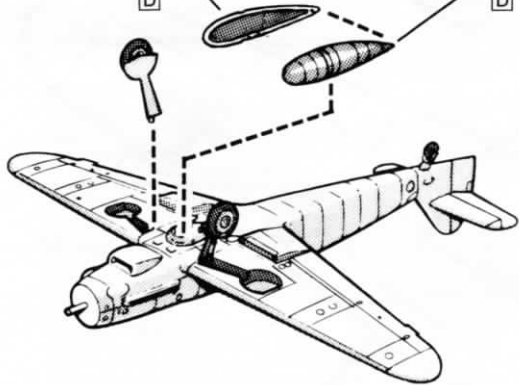

12

ANTENNA
25
D

MASS
BALANCE
26
D

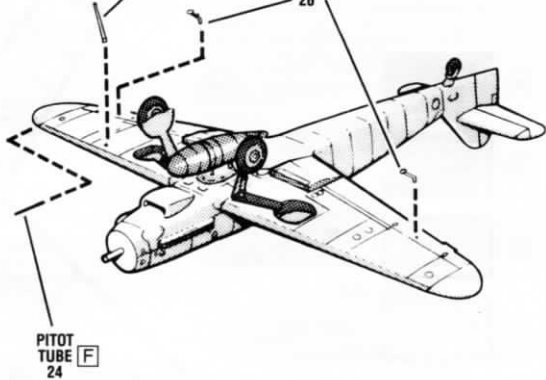

13

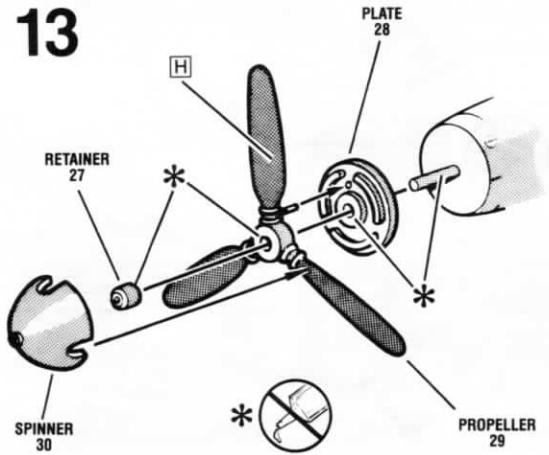

14

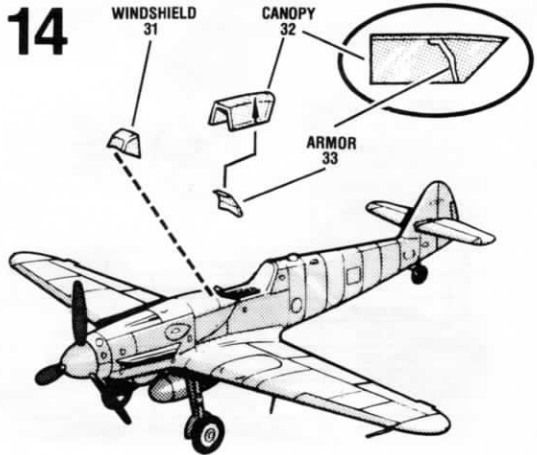

15

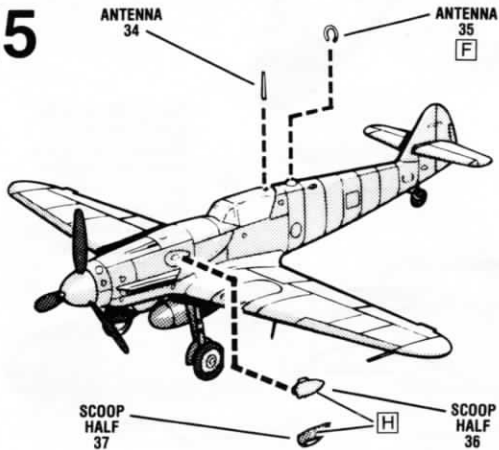

If you have any problems building this model, call our modeling tips hotline at:

(800) 833-3570

Every effort has been made to create and manufacture a model kit that is the finest available. If a part may be missing, please write to:

Monogram Models, Incorporated
Consumer Service Department
395 North Third Avenue
Des Plaines, Illinois 60016

Be sure to include the kit number, part number, description, and your return address.

5225 M 0200

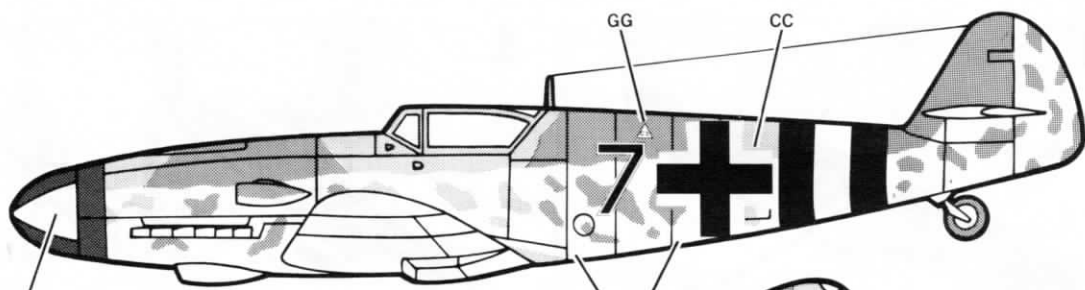

G

GG

CC

EE

- GREEN LIGHT
- GRÜNE LICHT
- LUZ VERDE
- GROEN LICHT
- FEU VERT
- GRÖNT LJUS
- LUCE VERDE

- RED LIGHT
- ROTE LICHT
- LUZ ROJA
- ROOD LICHT
- FEU ROUGE
- RÖTT LJUS
- LUCE ROSSA

DD

AA

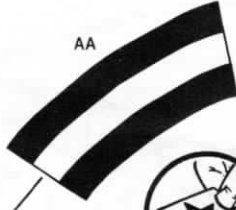

- | | | |
|--|---|------------------------|
| | A | RLM 70
SCHWARZ GRÜN |
| | B | RLM 81
BRAUNVIOLETT |
| | C | RLM 82
DUNKLE GRÜN |
| | D | RLM 76
LICHTBLAU |

BB



- USE BLACK THREAD
- BENUTZEN SIE DEN SCHWARZEN FADEN
- * GESE HILÓ NEGRO
- * GEBRUIK ZWART DRAAD
- * UTILISER LE FIL NOIR
- ANVÄND SVART TRÅD
- USARE FILO NERO

*

FF

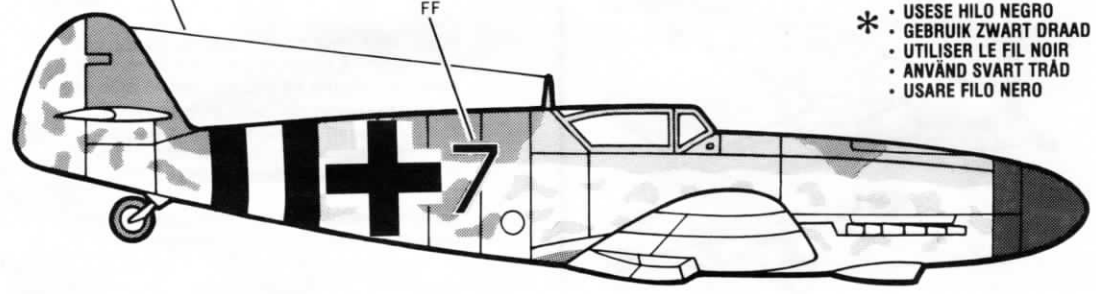

Messerschmitt Bf 109 5225M0300

©COPYRIGHT MONOGRAM INC. 1990
ALL RIGHTS RESERVED

AA



BB



DD



EE



CC



FF



GG



APPLICATION INSTRUCTIONS :

- 1) WASH PLASTIC PARTS IN MILD DETERGENT SOLUTION. RINSE AND LET DRY.
- 2) CUT DESIRED DECAL FROM SHEET.
- 3) DIP DECAL IN WATER FOR A FEW SECONDS.
- 4) PLACE WET DECAL ON PAPER TOWEL.
- 5) WAIT UNTIL DECAL IS MOVABLE ON PAPER BACKING.
- 6) PLACE DECAL IN POSITION ON MODEL, FACE UP AND SLIDE BACKING AWAY.
- 7) PRESS OUT AIR BUBBLES WITH A SOFT DAMP CLOTH.
- 8) MILKINESS THAT MAY APPEAR IS FOR BETTER DECAL ADHESION AND WILL DRY CLEAR. WIPE AWAY ANY EXCESS ADHESIVE.
- 9) DO NOT TOUCH DECAL UNTIL FULLY DRY.

XI-6446C

7-25-93



5823 F-15C Eagle

5505 A-10 Thunderbolt



5443 AH-64 Apache



5832 High Tech
F-14A Tomcat



5207 P-51 Mustang

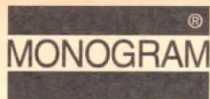

CATALOG OFFER

Send \$3.00 check or money order (no cash) and this card to:

Monogram Catalog Offer
P.O. Box 68849
Schaumburg, IL 60194

NAME _____

ADDRESS _____

CITY _____ STATE _____ ZIP _____

YES, SEND A CATALOG

YES, ADD ME TO YOUR MAILING LIST

AGE:

UNDER 8

8-12

13-19

20-39

40-ABOVE

NUMBER OF MODELS BUILT IN PAST YEAR?

3 OR LESS

8 OR MORE

4-7

WHAT DO YOU PREFER TO BUILD MOST OFTEN?

CARS

SHIPS

PLANES

WOULD YOU BE INTERESTED IN A MODEL BUILDERS CLUB? YES NO

Allow 4 to 6 weeks for delivery.

OFFER GOOD ONLY IN U.S.A.

0016M3563