

# Revell

KIT 5860

85586000200

# MIG 25 FOXBAT

The Mikoyan-Gurevich MiG 25 (NATO reporting name, Foxbat) is a high-supersonic interceptor and reconnaissance/bomber aircraft. The MiG 25's first flight as a prototype was in 1964 and entered service in 1970. With a top speed of mach 2.83+, a powerful radar unit and four air-to-air missiles, this worried Western observers and prompted the development of the F-15 Eagle in the late 60's.

Your Revell model features a detailed cockpit with optional position canopy, optional position landing gear, four AA-6 Acrid missiles and authentic decal markings for two separate versions.



\* REPEAT SEVERAL TIMES  
\* A REPETER PLUSIEURS FOIS

\* REPEAT PROCEDURE  
\* RÈPÈTEZ LE PROCÈDE

\* OPTIONAL PARTS  
\* PIÈCES EN OPTION

\* DECAL  
\* DECAL COMANIE

\* ASSEMBLY CAUTION  
\* ATTENTION D'ASSEMBLÉE

\* CEMENT TOGETHER  
\* A COLLER

\* REMOVE AND THROW AWAY  
\* A RETIRER ET JETER

\* DO NOT CEMENT  
\* NE PAS COLLER

### READ THIS BEFORE YOU BEGIN

- \* Study the assembly drawings.
- \* Each plastic part is identified by a number.
- \* In the assembly drawings, some parts will be marked by a star (★) to indicate chrome plated plastic.
- \* For better paint and decal adhesion, wash the plastic parts in a mild detergent solution. Rinse and let air dry.
- \* Check the fit of each piece before cementing in place.
- \* Use only cement for polystyrene plastic.
- \* Scrape plating and paint from areas to be cemented.
- \* Allow paint to dry thoroughly before handling parts.
- \* Any unused parts may be discarded.

### DECAL APPLICATION INSTRUCTIONS

1. Cut desired decal from sheet.
2. Dip decal in water for a few seconds.
3. Place wet decal on paper towel.
4. Wait until decal is movable on paper backing.
5. Place decal in position on model, face up and slide backing away.
6. Press out air bubbles with a soft damp cloth.
7. Milkiness that may appear is for better decal adhesion and will dry clear. Wipe away any excess adhesive.
8. Do not touch decal until fully dry.
9. Allow the decals 48 hours to dry before applying clear coat.

**NOTE:** Decals are compatible with setting solutions or solvents.

### LIRE CE QUI SUIT AVANT DE COMMENCER

- \* Etudier les schémas de montage.
- \* Chaque pièce en plastique est identifiée par un numéro.
- \* Sur les schémas de montage, certaines pièces sont marquées d'une étoile (★) pour indiquer qu'elles sont en plastique chromé.
- \* Pour une meilleure prise de la peinture et des autocollants, laver les pièces en plastique avec une solution détergente peu concentrée. Les rincer et les laisser sécher à l'air.
- \* Vérifier que chaque pièce s'ajuste bien avant de la coller en place.
- \* N'utiliser que de la colle pour polystyrène.
- \* Gratter les parties à coller pour enlever le chrome et la peinture.
- \* Laisser la peinture bien sécher avant de manipuler les pièces.
- \* Toute pièce inutilisée peut être jetée.

### DIRECTIVES D'APPLICATION DES AUTOCOLLANTS

1. Découper l'autocollant désiré de la feuille.
2. Tremper l'autocollant dans de l'eau pendant quelques secondes.
3. Placer l'autocollant mouillé sur une serviette en papier.
4. Attendez que l'autocollant puisse être déplacé sur son support en papier.
5. Mettre l'autocollant en position sur le modèle face sur le dessus et faire glisser le support pour l'enlever.
6. Appuyer avec un chiffon doux humide pour éliminer les bulles d'air.
7. La substance laiteuse qui peut apparaître est destinée à améliorer l'adhésion de l'autocollant et devient incolore au séchage. Essuyer pour enlever tout excédent d'adhésif.
8. Ne pas toucher l'autocollant tant qu'il n'est pas bien sec.
9. Laisser l'autocollant sécher pendant 48 heures avant d'appliquer une couche transparente.

**REMARQUE:** Les autocollants sont compatibles avec les solutions de fixation ou les solvants.

This paint guide is provided to complete this kit as shown on the box.

Ce guide de peintures est fourni pour reproduire le modèle réduit qui apparaît sur la boîte.

Flat Black	Noir mat
Armor Sand	Sable armure
Light Blue	Bleu clair
White	Blanc
Steel	Acier
Dark Ghost Gray	Gris fantôme foncé
Gull Gray	Gris cendré clair
Field Green	Verte champêtre
Dark Tan	Havane foncé

If you have any questions or comments, call our hotline at: **(800) 833-3570**  
or, please write to:

Revell Inc Consumer Service Department, 1850 Howard Street Unit A, Elk Grove Village, Illinois 60007

Be sure to include the plan number (85586000200), part number, description, your return address and phone number.

Visit our website: [www.revell.com](http://www.revell.com)

# 1

# COCKPIT ASSEMBLY

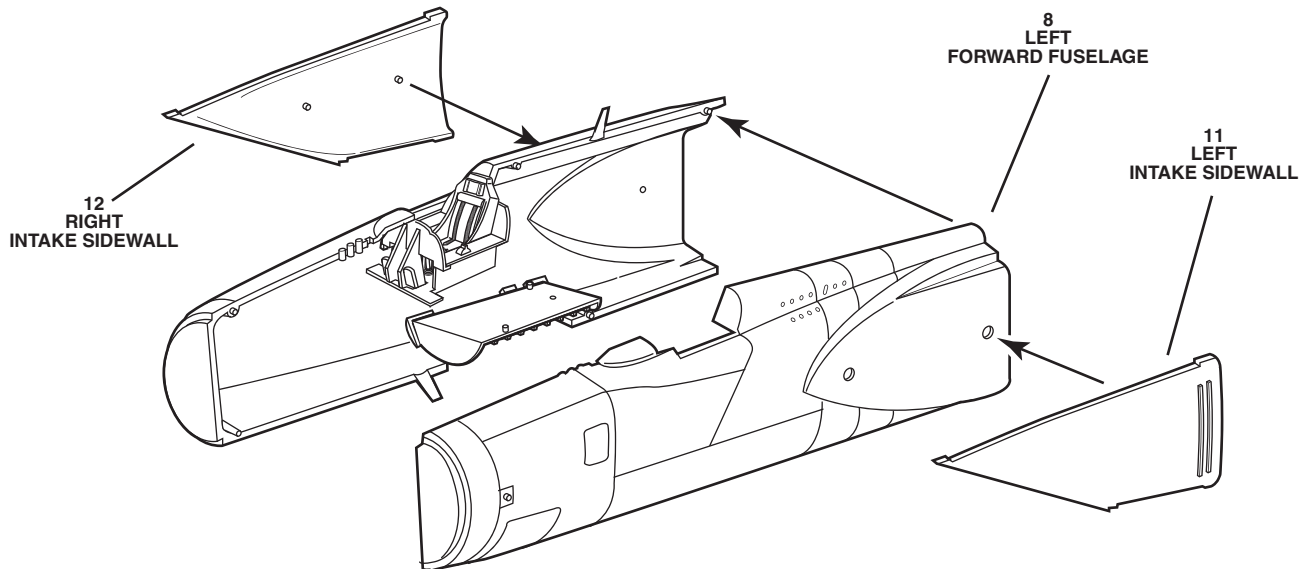
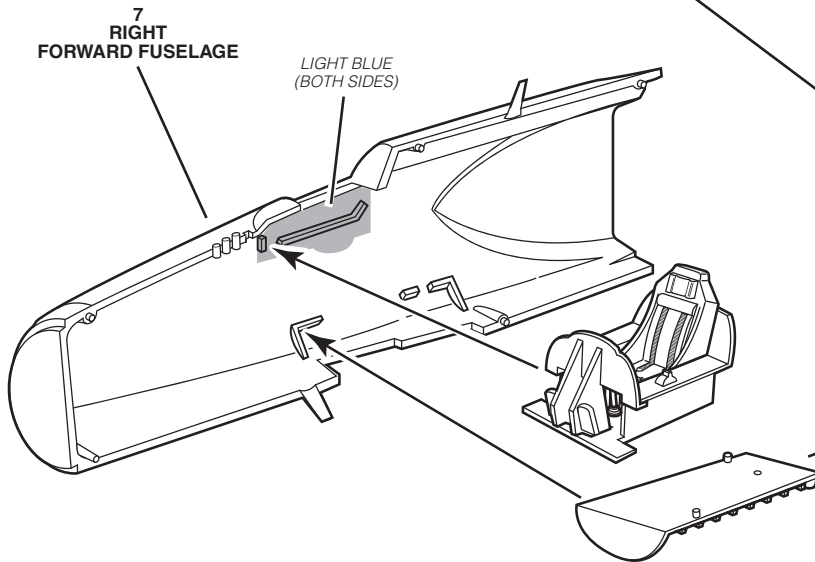
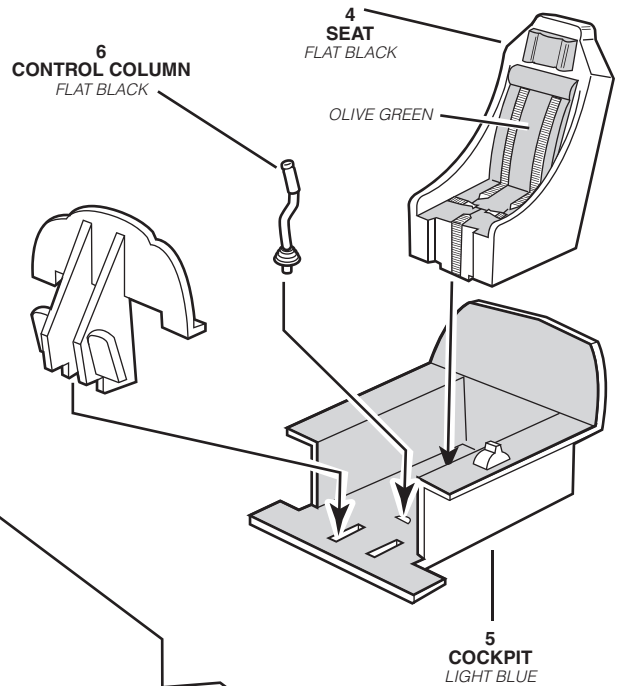
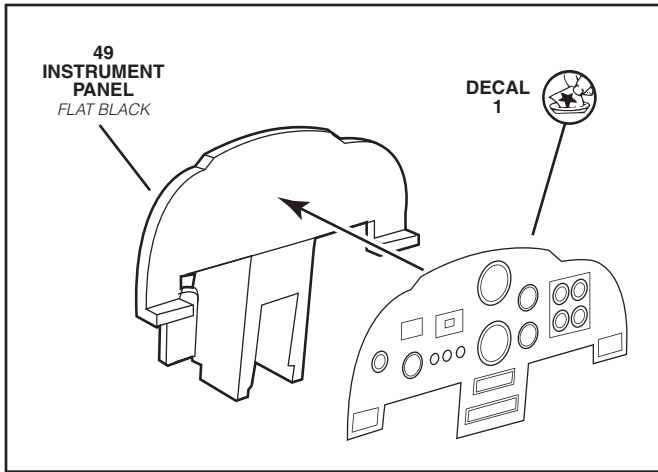

# 2

# RADOME / AFT FUSELAGE ASSEMBLY

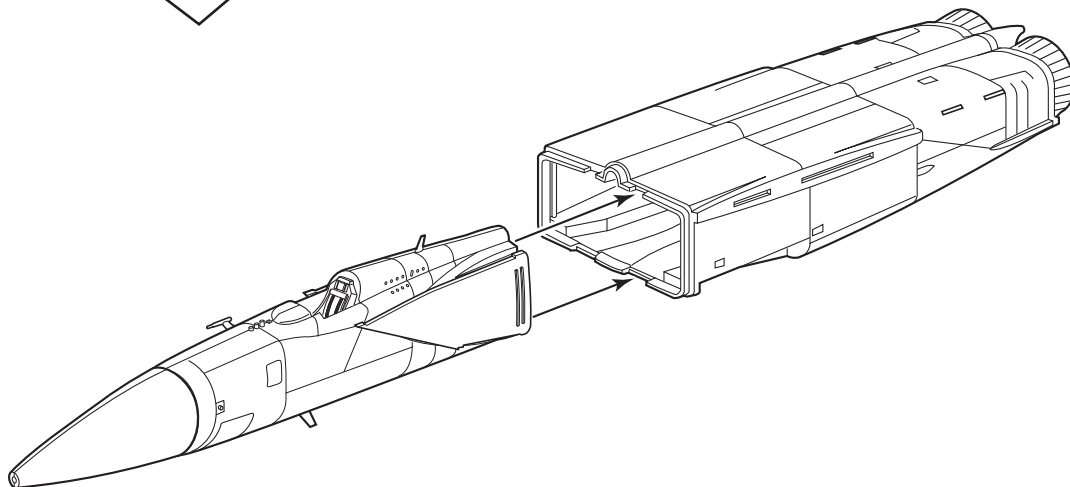
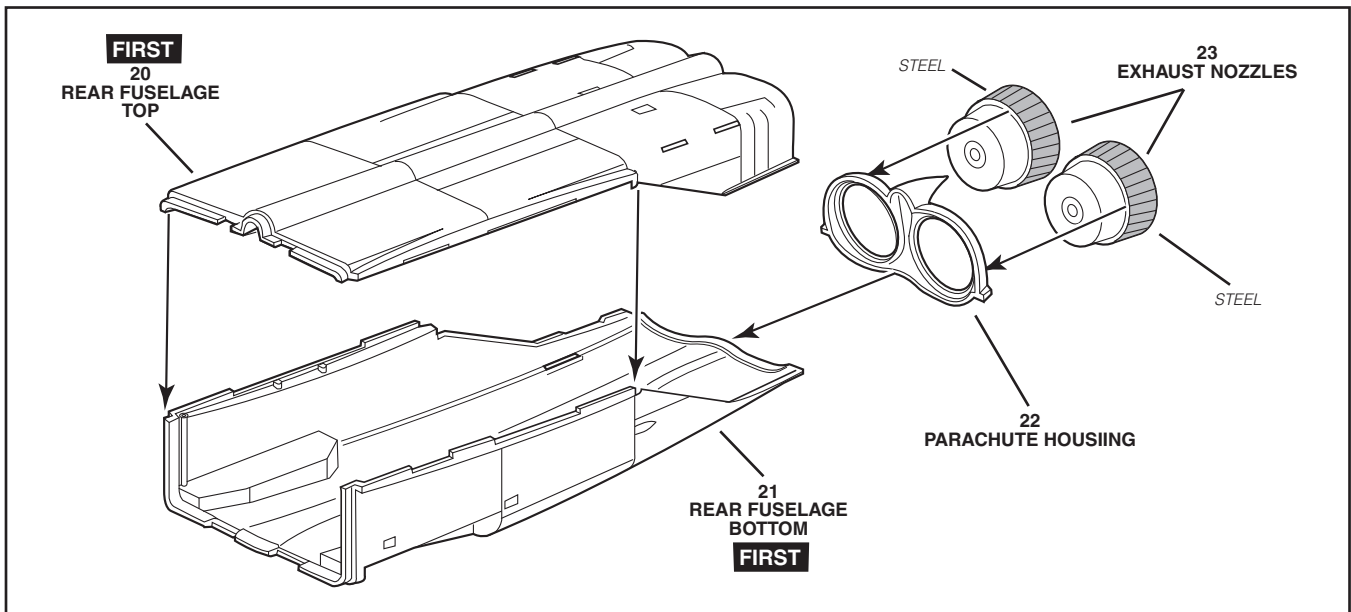
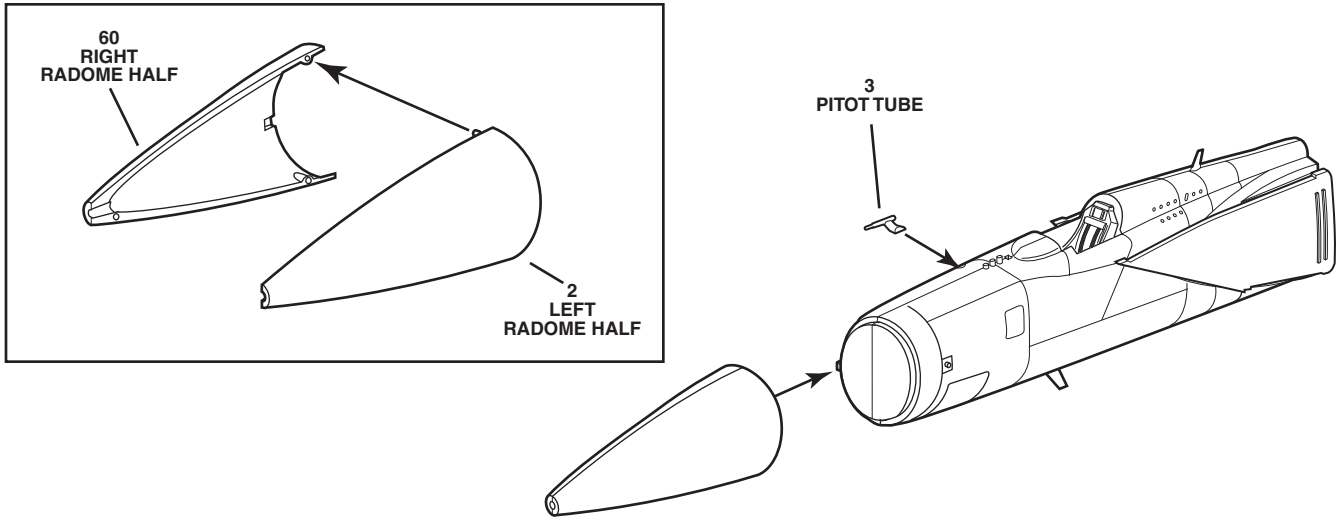

# 3

# INTAKE ASSEMBLY

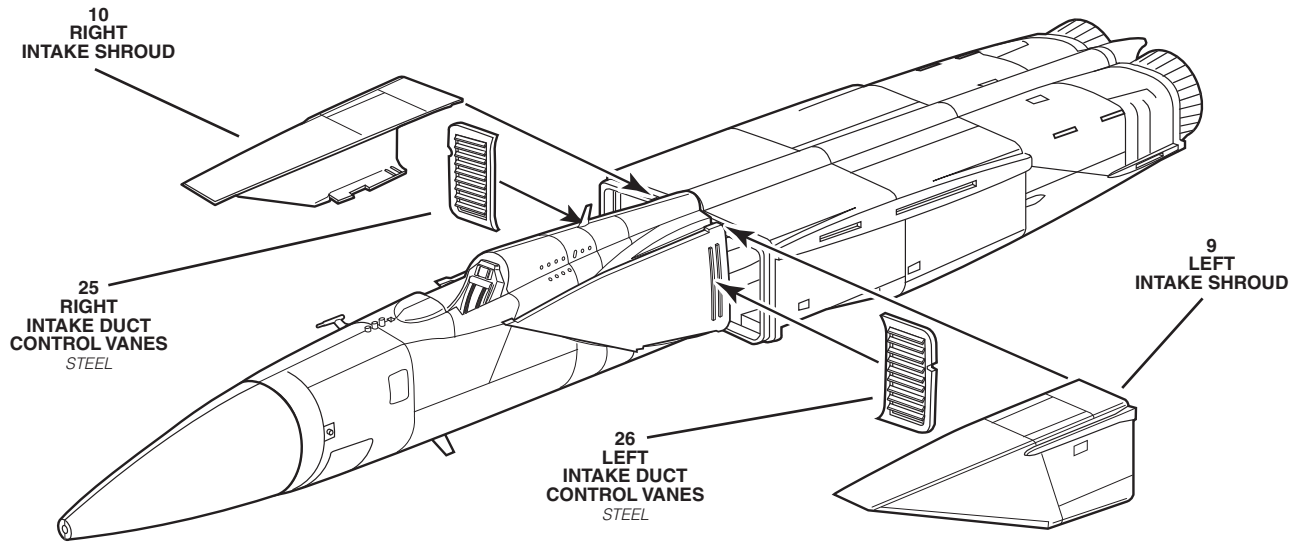

# 4

# VERTICAL TAIL ASSEMBLY

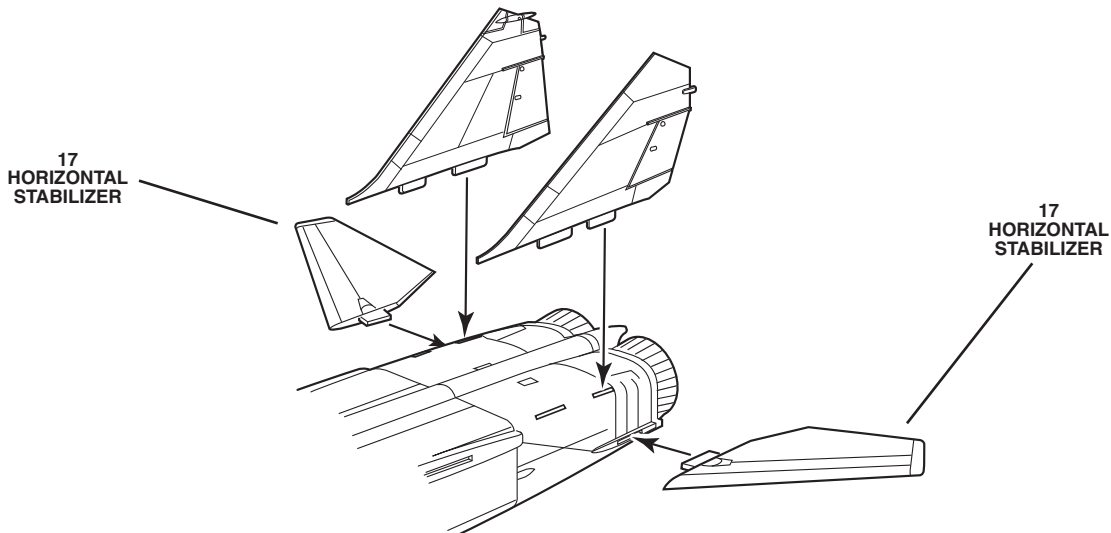
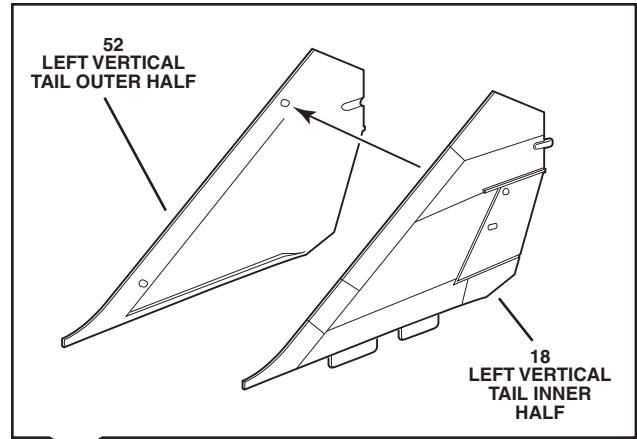
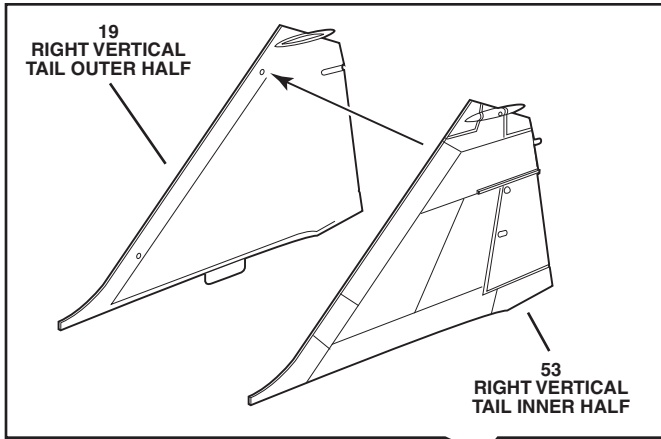

# 5

# WING ASSEMBLY

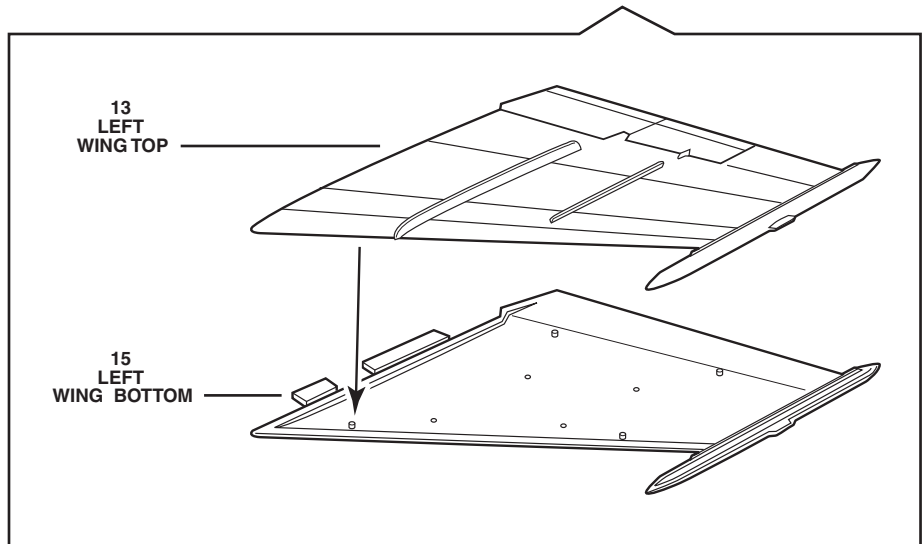
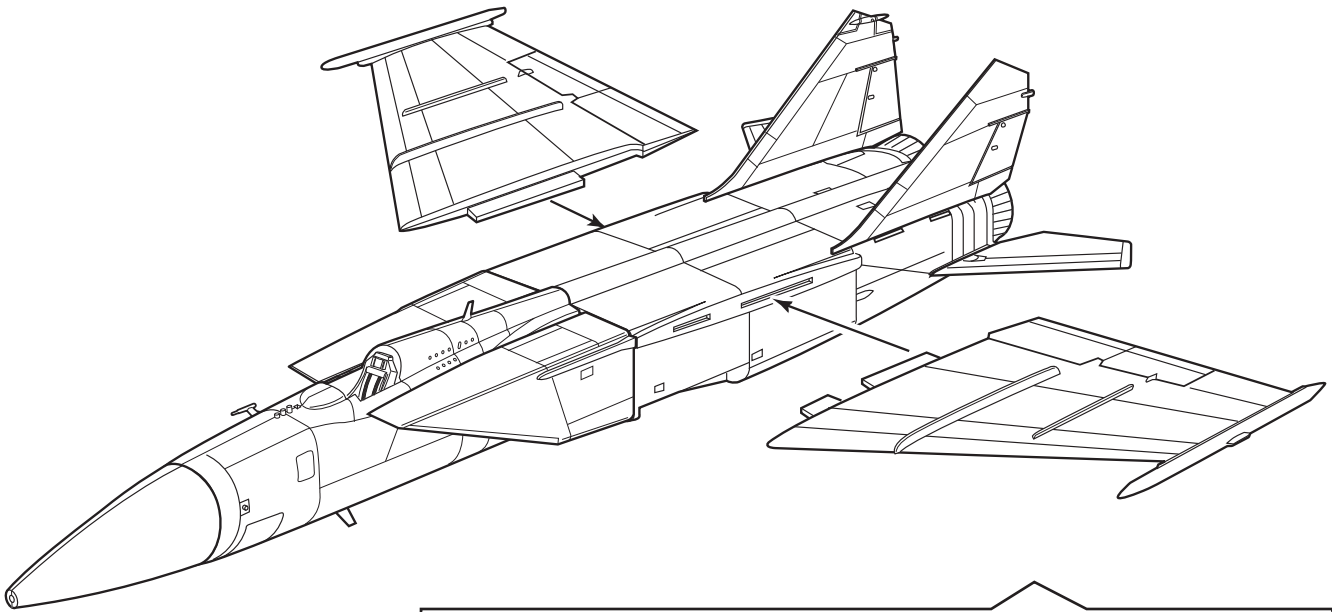
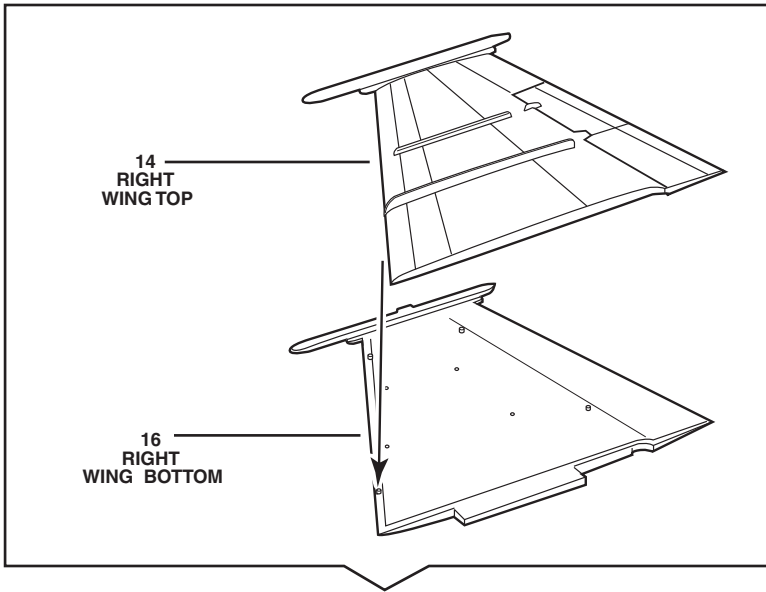

# 6

# INTAKE PANEL / FIN ASSEMBLY

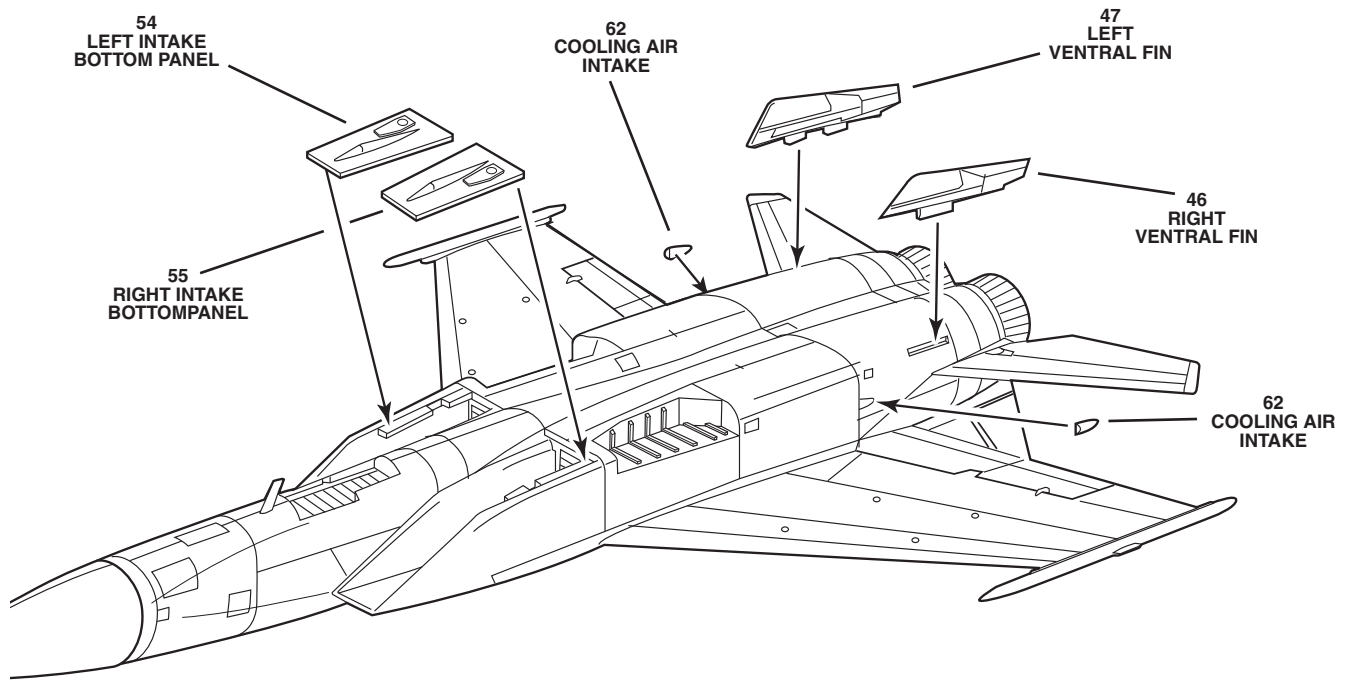

# 7

# MAIN WHEEL ASSEMBLY



SEE STEP 10

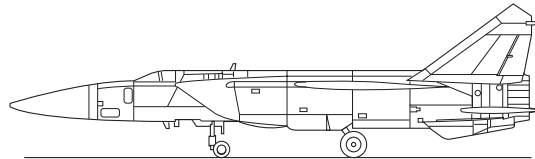

GEAR UP POSITION

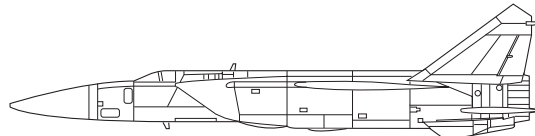

GEAR DOWN POSITION

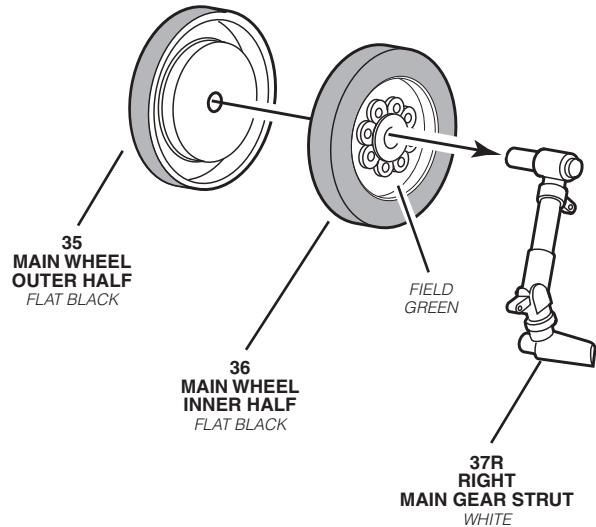
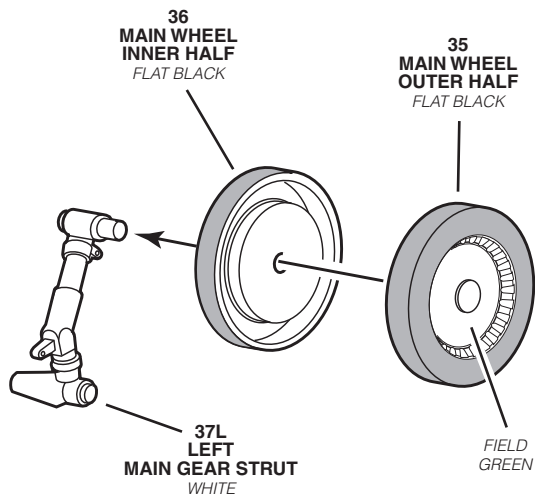

# 7

# WHEEL ASSEMBLY CONTINUED

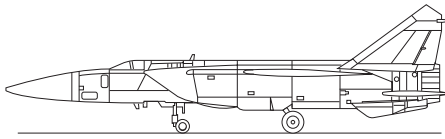

**GEAR DOWN POSITION**

**LEFT**

**RIGHT**

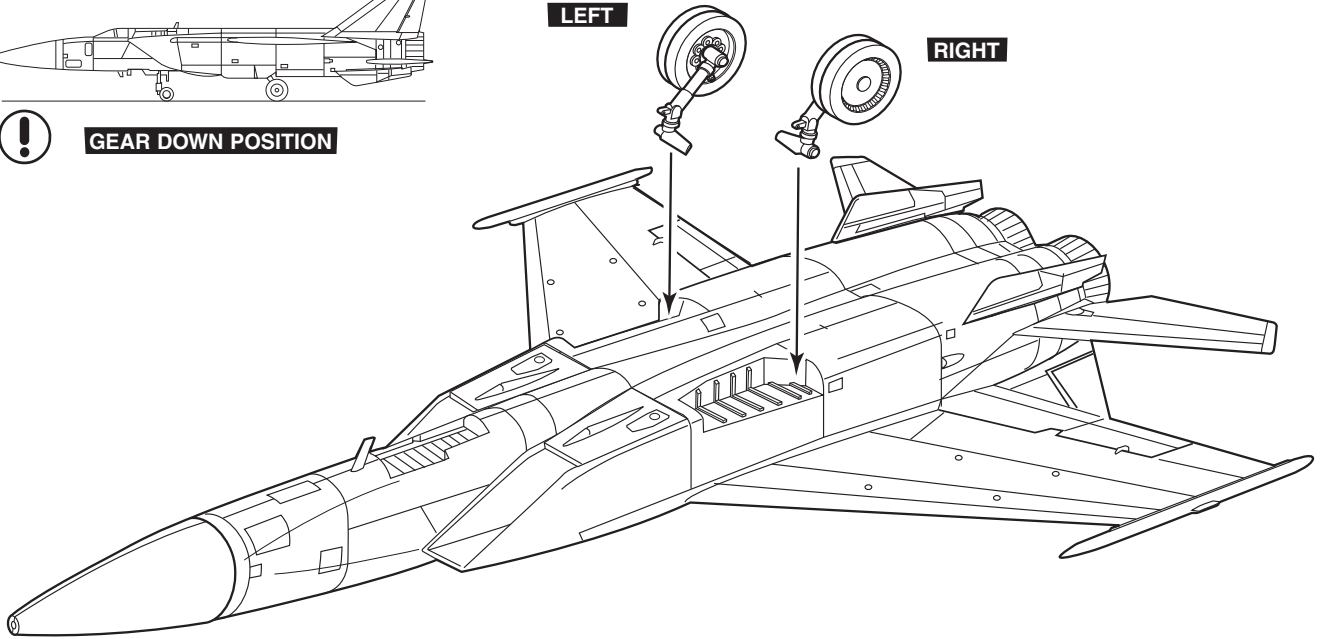

# 8

# OPEN DOOR ASSEMBLY

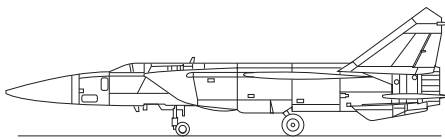

**GEAR DOWN POSITION**

**40**  
**LEFT**  
**MAIN REAR DOOR**  
STEEL  
(INSIDE ONLY)

**41**  
**RIGHT**  
**MAIN FORWARD DOOR**  
STEEL  
(INSIDE ONLY)

**39**  
**RIGHT**  
**MAIN REAR DOOR**  
STEEL  
(INSIDE ONLY)

**42**  
**LEFT**  
**MAIN FORWARD DOOR**  
STEEL  
(INSIDE ONLY)

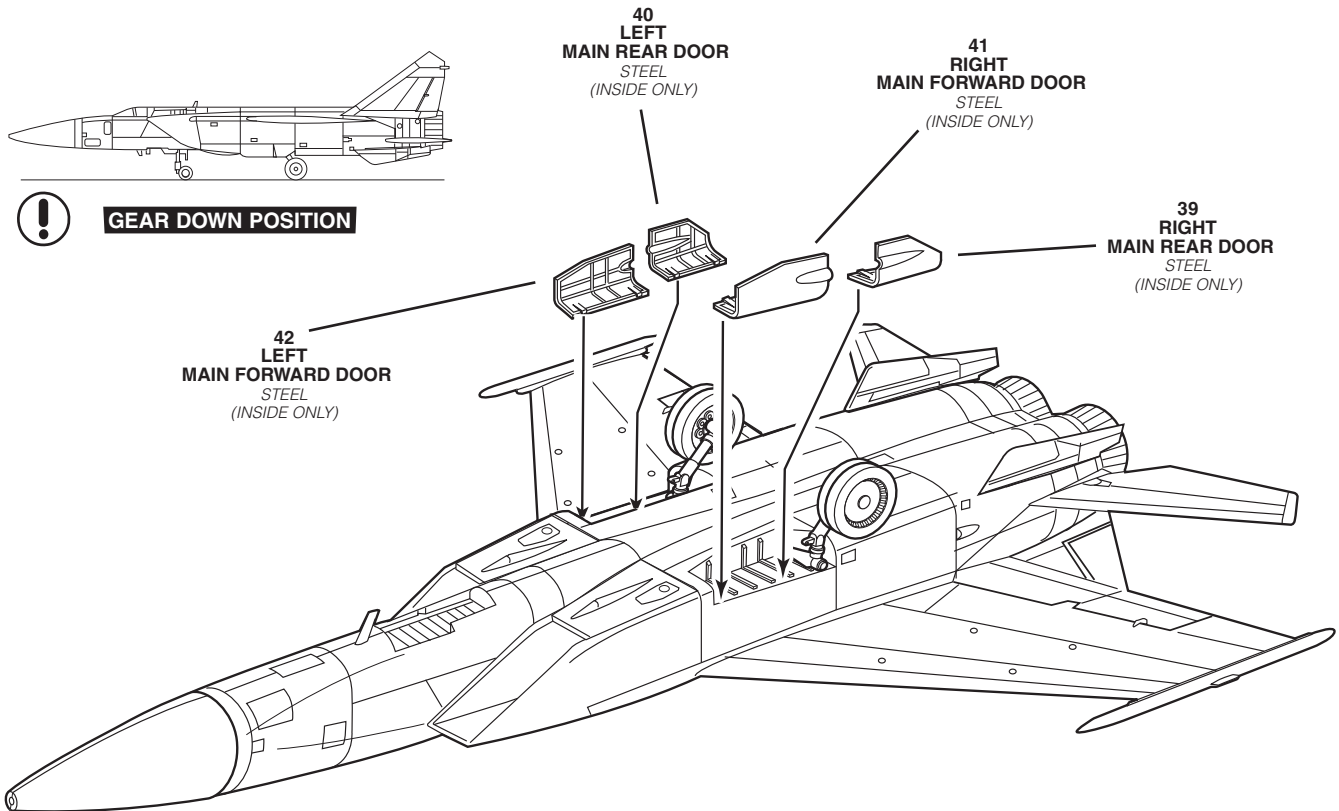

# 9

# NOSE WHEEL ASSEMBLY

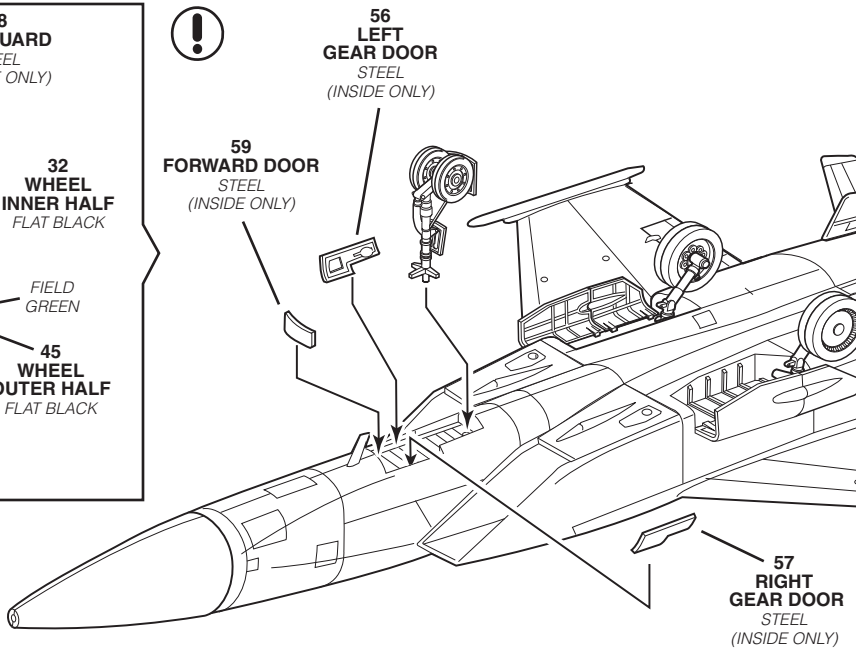
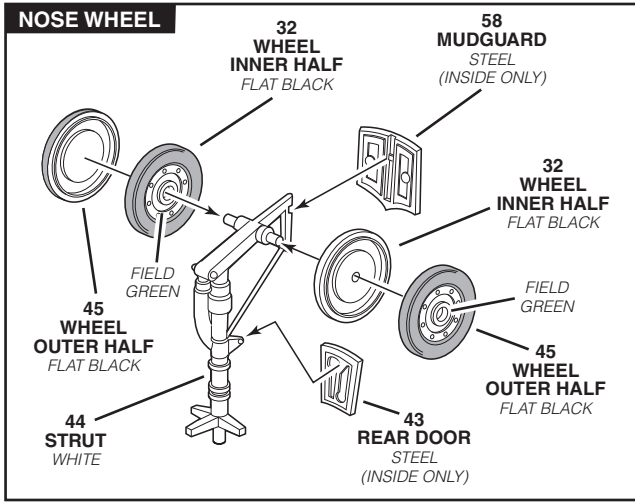

# 10

# CLOSED DOOR ASSEMBLY

REMOVE HINGES FROM PARTS 39, 40, 41 AND 42

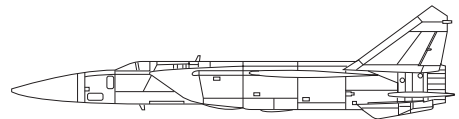
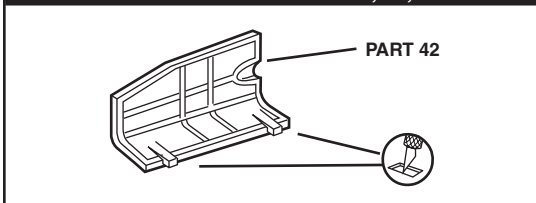

**GEAR UP POSITION**

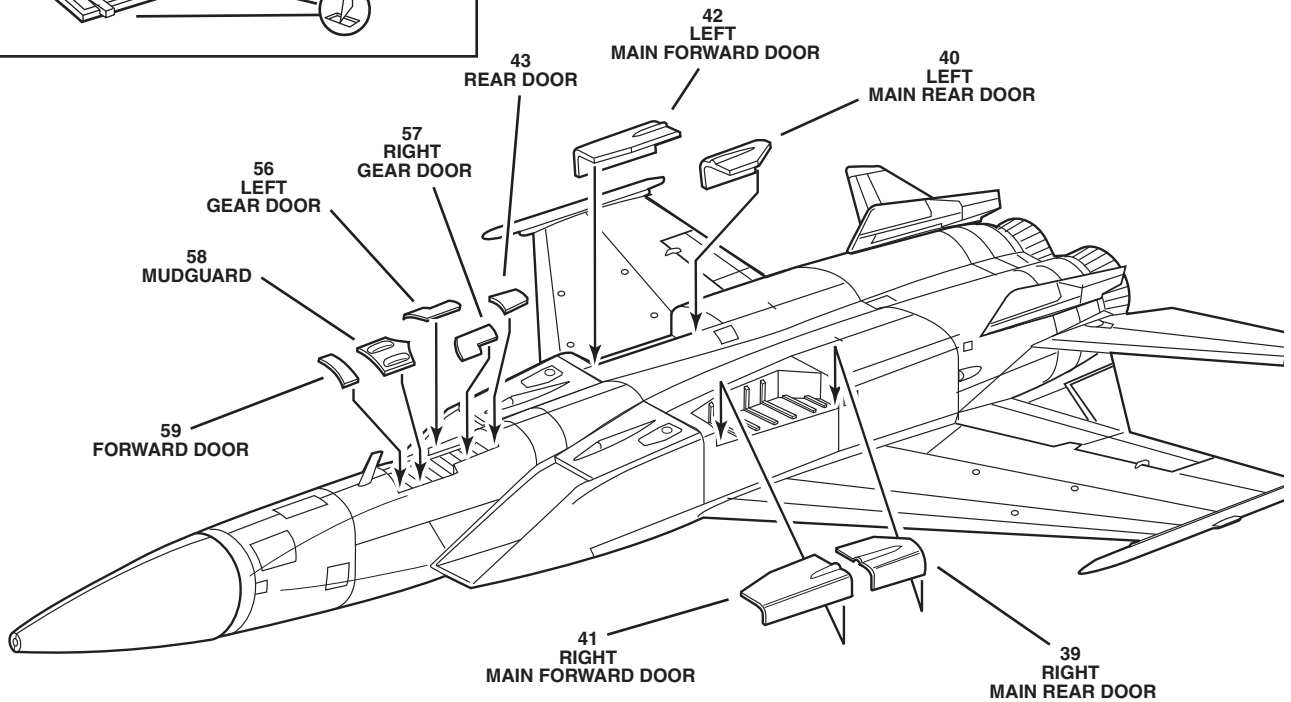



# 11

# PYLON ASSEMBLY

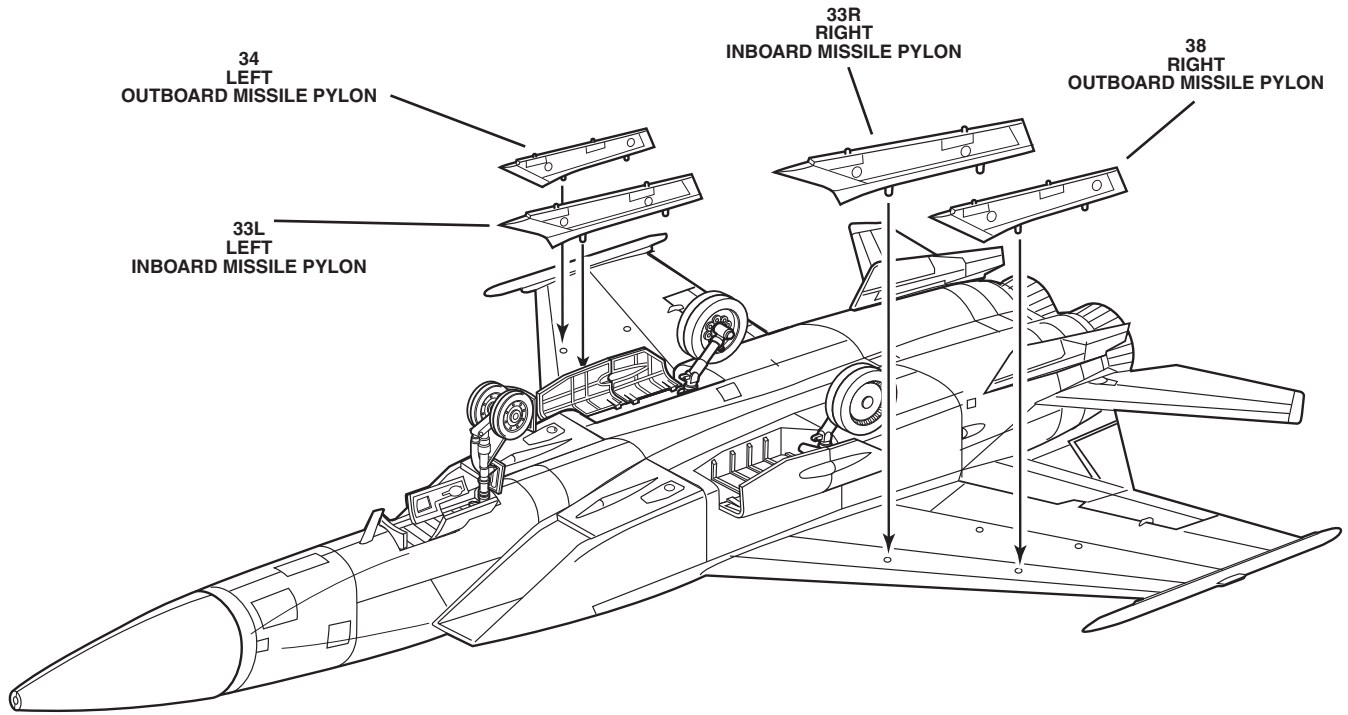

# 12

# MISSILE ASSEMBLY

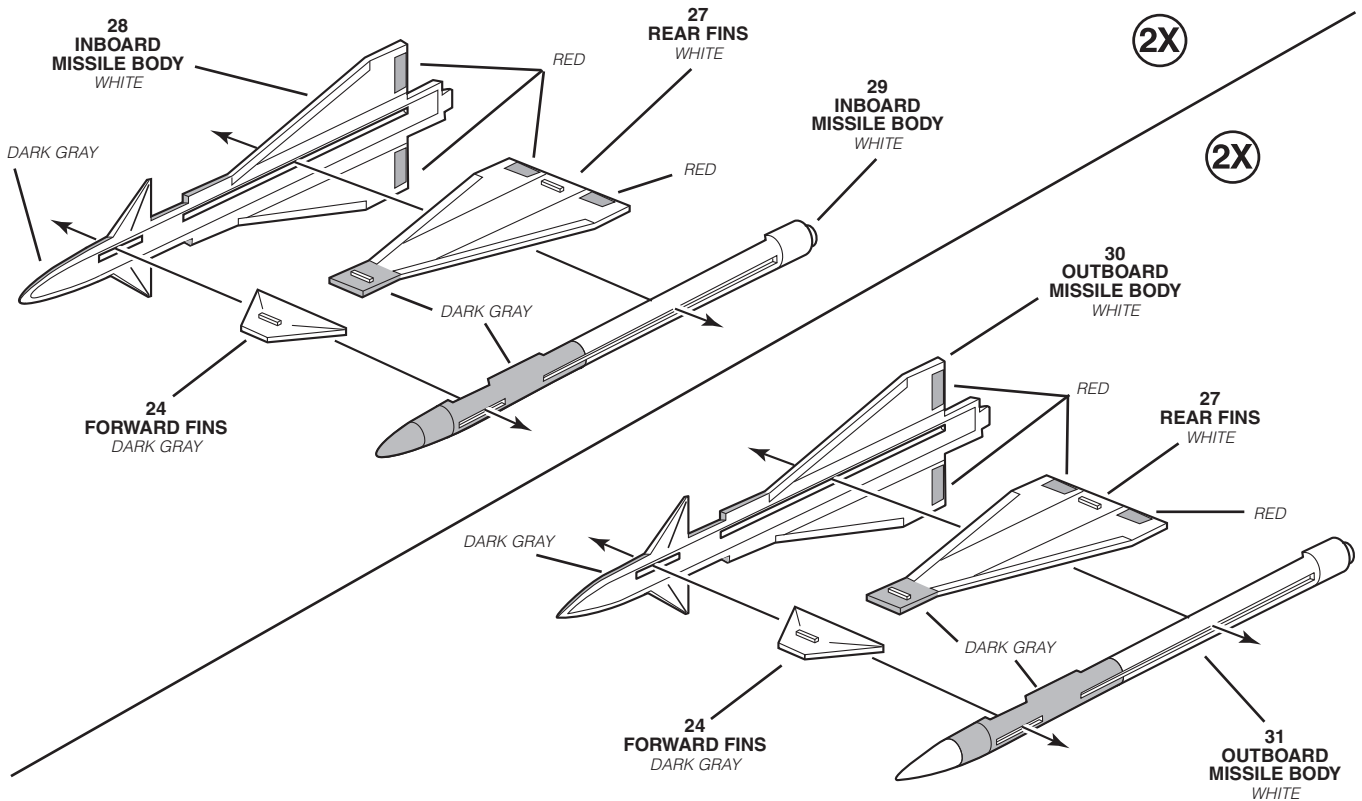

# 13

# MISSILES TO FUSELAGE ASSEMBLY

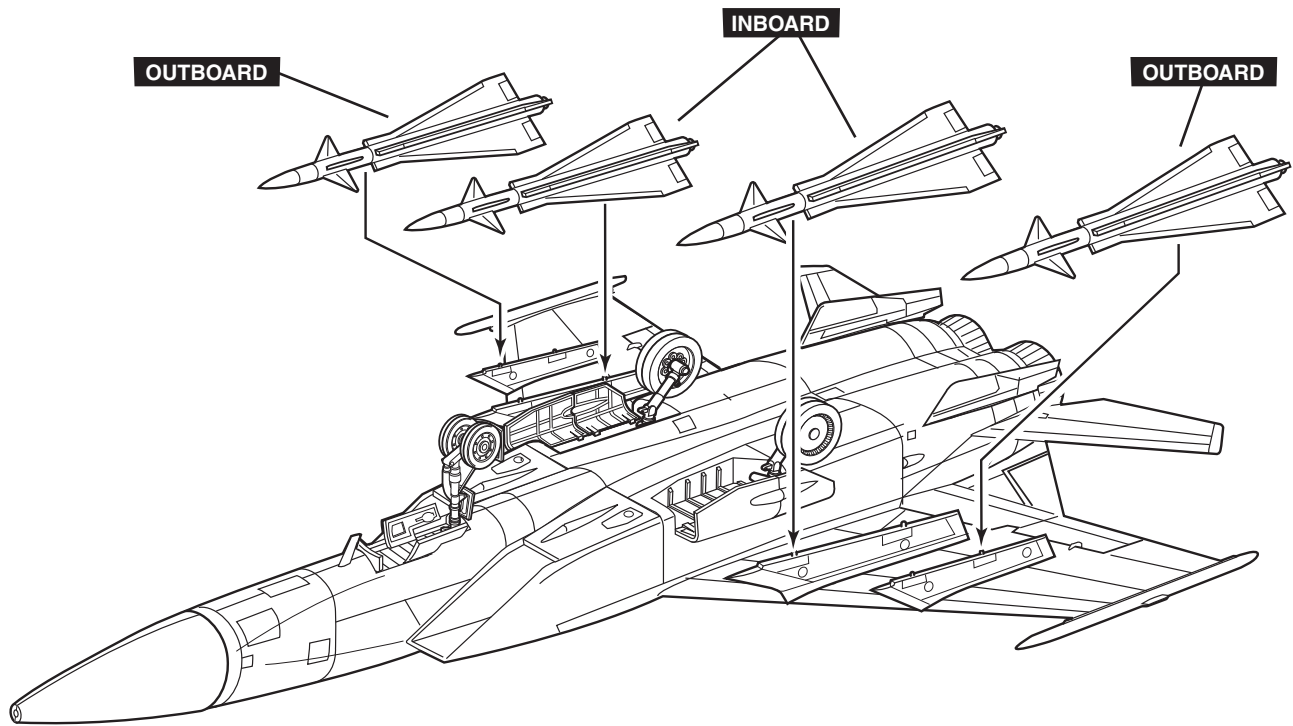

# 14

# CANOPY ASSEMBLY

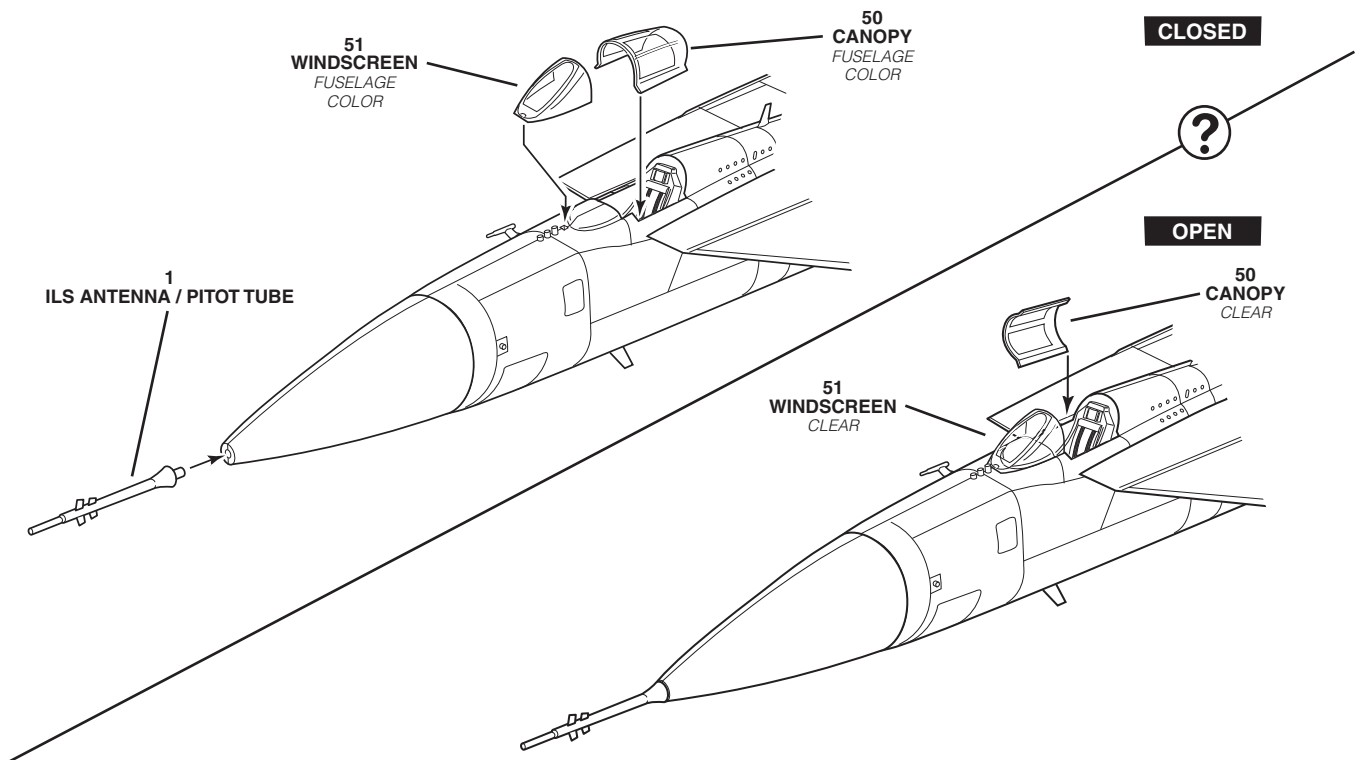

# DECAL PLACEMENT

MiG 25 RBK FOXBAT, RED 38, ORAP (INDEPENDENT RECCE AVIATION REGIMENT), WERNEUCHEN, BRANDENBURG, GERMANY, 1990.

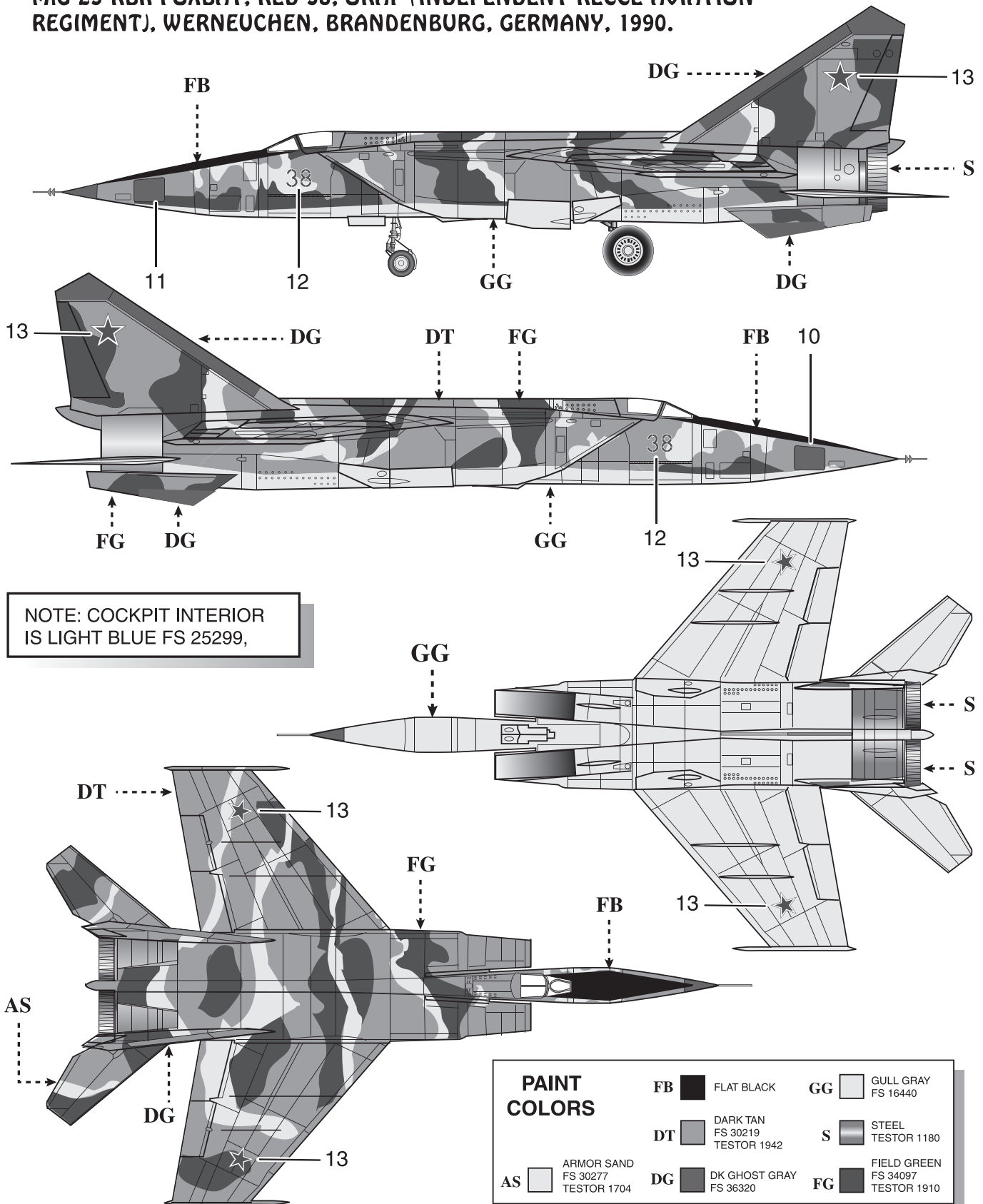

**MiG 25 RB FOXBAT, KP554, 102 SQUADRON, INDIAN AIR FORCE, 1985.**

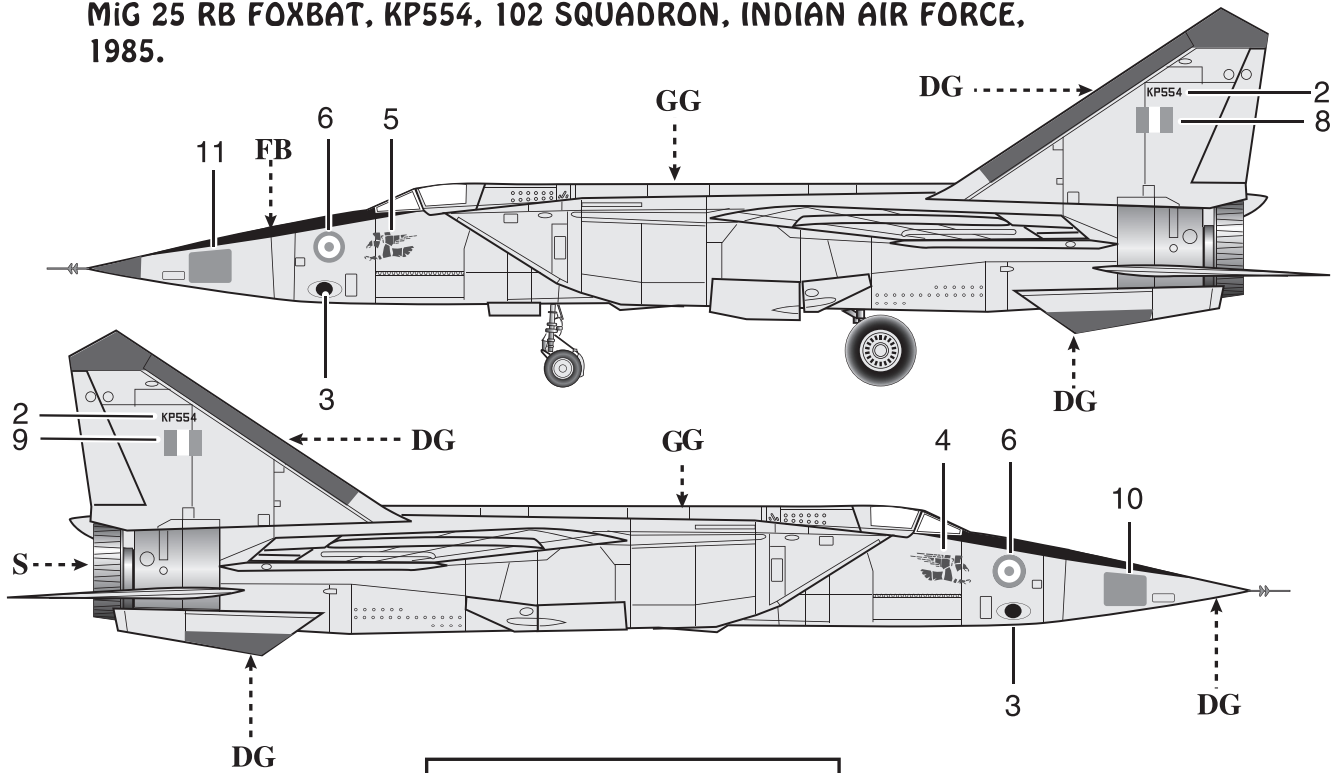

**NOTE: COCKPIT INTERIOR IS LIGHT BLUE FS 25299,**

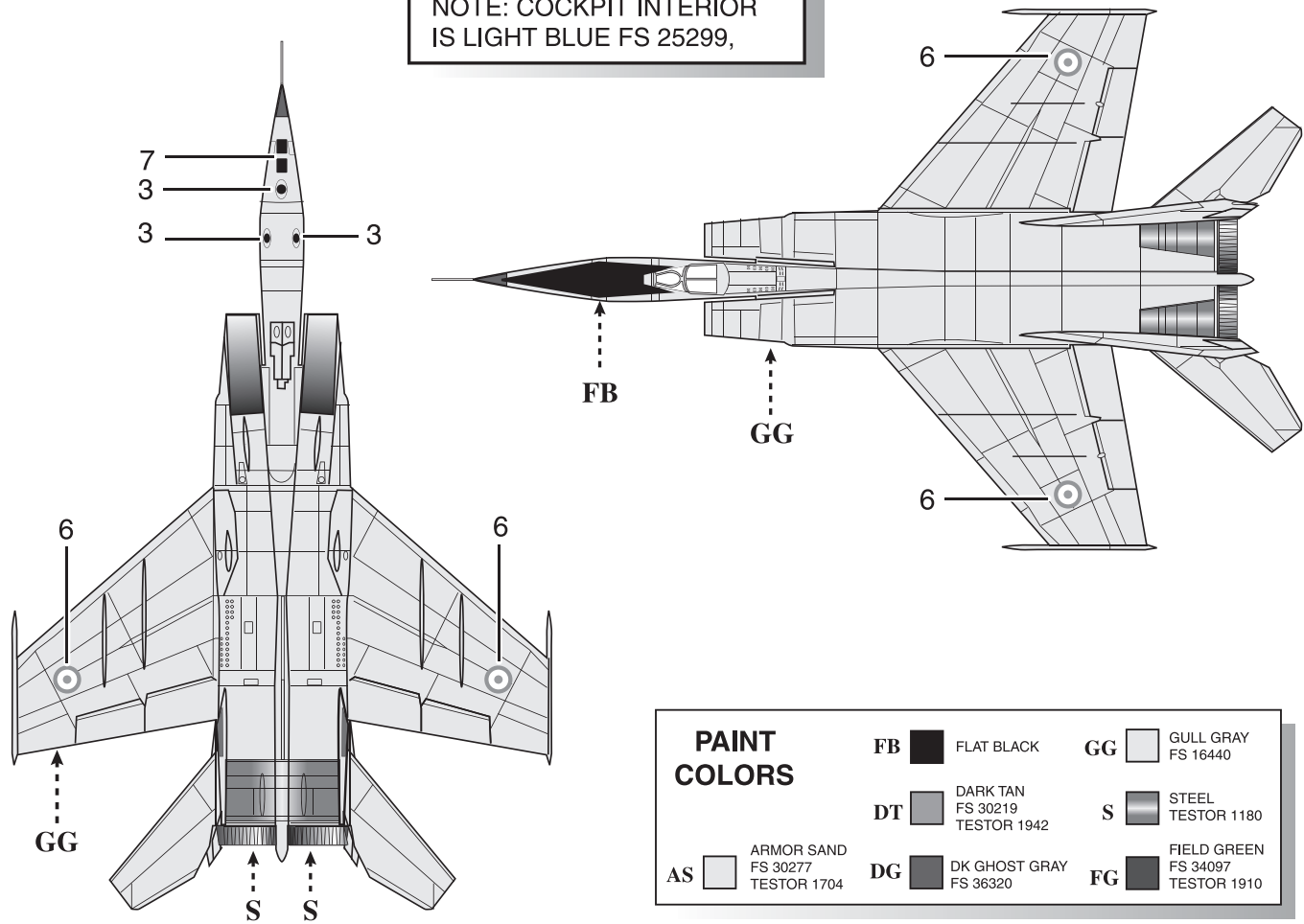

PAINT COLORS			
<b>FB</b>	FLAT BLACK	<b>GG</b>	GULL GRAY FS 16440
<b>DT</b>	DARK TAN FS 30219 TESTOR 1942	<b>S</b>	STEEL TESTOR 1180
<b>AS</b>	ARMOR SAND FS 30277 TESTOR 1704	<b>DG</b>	DK GHOST GRAY FS 36320
		<b>FG</b>	FIELD GREEN FS 34097 TESTOR 1910