

US NAVY WWII NIGHT FIGHTER 1:48 SCALE PLASTIC KIT



eduard

F6F Hellcat intro by Jan Zdiarský

There are few aircraft types that took part in combat during World War Two, that can be described with such one sided outcomes in terms of kill : loss ratio as the Hellcat. Representing the middle of the Grumman Cat lineage, the Hellcat was a unique type right from its beginnings. Success of its older brother, the Wildcat, which carried on its shoulders the bulk of the strain of the Pacific air war in 1942, prompted the US Navy to give Grumman free reign over the independent development of a new fighter. This type was to act as insurance in the event the concept of the F4U Corsair turned out unsuccessful. Grumman designers set forth with the design, with emphasis on ease of manufacture, performance and suitability for carrier ops.

On the 30th of June, 1941, as Corsair production was initiating, the Navy signed an order for two prototype XF6F-1s, and a star was born. Original expectations centered around development of the proven F4F Wildcat, which was to be dominated by installation of more powerful engines. As such, this eventually evolved into a new fighter altogether. The US Navy also had accumulated combat experience, and was able to incorporate pilot suggestions into the design. The Hellcat was some 60% heavier than the Wildcat, was more heavily armed, had a more powerful engine, was more heavily armored, carried more fuel and was generally of a more robust construction. The first prototype took to the air on June 26th, 1942, and by January, 1943 equipped the first Navy unit, VF-9, on the deck of the USS Essex.

The new type was called Hellcat. The name not only suggested the place to which her enemies would be sent, but was also a play on words. The term in the old west referred to barroom brawlers, and that was what the Navy wanted: a tough fighter with hard fists, that could absorb punishment and had stamina. The Hellcat line didn't result in the most elegant of fighters. It was, after all, over twice as heavy as its main adversary, the Japanese A6M Zero. But elegance certainly doesn't play a pivotal role in terms of the potential survival of the pilot. It was a fighter first and foremost in every sense of the word, designed around the requirements of the pilot to fulfill the combat mission for which it was designed and he was trained. The initial version, F6F-3, was supplanted by the dash five, which modified the canopy, cowl, bombracks and droptanks.

The first combat engagement of the enemy occurred on September 1st, 1943, when an Emily was flamed by the half inch guns of two Hellcats. Their advantage over Japanese fighters was well demonstrated on February 16th, 1944, when, in the vicinity of Truk, over 100 fighters were claimed in the air and over 150 on the ground for the loss of four aircraft. Five days later, in the Marianas, a further 160 enemy aircraft were destroyed in the air and on the ground. Often one sided combat was documented in the battle for the Philippine Sea that culminated on June 19th, 1944 in the now legendary 'Great Marianas Turkey Shoot', where Hellcat pilots claimed some 350 enemy aircraft destroyed. A further turkey hunt took place between October 12th and 14th, 1944 over Formosa, seeing the destruction, at the hands of Hellcat pilots, of 300 enemy aircraft for the loss of 27.

In October, 1944, the Japanese began to escalate night attacks, bringing on a requirement for night fighters to counter them. USAAF P-61s were too far off. Night fighting variants of the Hellcat were introduced in the form of the F6F-3N and F6F-5N, equipped with radar. This new role for the Hellcat first appeared at the end of fall, 1944 during the intensification of kamikaze attacks, that required the interception of unorthodox attacks by aircraft that avoided air to air combat. Other major combat was seen over the Japanese islands over the first half of 1945.

Although the Hellcat was progressively replaced by its stablemate F4U Corsair, it served in the combat role up to the end of the war. Under the designation Hellcat F Mk 1 and II, several hundred served with the Royal Navy, notably in the Atlantic covering convoys, and also in the Far East.

According to statistics, there were 12275 Hellcats of all versions made. For the loss of 270 of these, Hellcat pilots claimed 5156 kills. That accounts for over half of USN and USMC victories. The Hellcat also became the most successful carrier based fighter in the Pacific in under two years of ops. Lumbering, awkward at first glance, lacking in elegance, barroom brawler – wild, tough, a fearless hulk, able to clear a saloon before turning three times.....that was the Hellcat in the skies over the Pacific.

Profiles artwork by Petr Štěpánek, profiles description by Martin Ferkl



VMF(N)-541, Falalop island, Ulithi Atoll, May 1945

ČESKOU VERZI TEXTU NALEZNETE NA
www.eduard.com/info/photos/8226

Pin-up girls were not common on aircraft of the US Marine Corps. Exceptions existed on aircraft used by VMF(N)-541. This Marine Corps unit was equipped with Hellcat nightfighters and fought against Japanese air forces over Palau Islands and the Philippines. From May 30, 1945 on, the airfield at Falalop island became the new unit's home. From this airbase, the unit flew patrol missions over the US Navy's forward base at Ulithi Atoll. VMF(N)-541 aircraft were adorned with the combat name 'Bat Eye', despite the fact that bats don't use their eyes for night flying.



Carefully read instruction sheet before assembling. When you use glue or paint, do not use near open flame and use in well ventilated room. Keep out of reach of small children. Children must not be allowed to suck any part, or pull vinyl bag over the head.



Před započetím stavby si pečlivě prostudujte stavební návod. Při používání barev a lepidla pracujte v dobře větrané místnosti. Lepidla ani barvy nepoužívejte v blízkosti otevřeného ohně. Model není určen malým dětem, mohlo by dojít k požití drobných dílů.



lire soigneusement la fiche d'instructions avant d'assembler. Ne pas utiliser de colle ou de peinture à proximité d'une flamme nue, et aérer la pièce de temps en temps. Garder hors de portée des enfants en bas âge. Ne pas laisser les enfants mettre en bouche ou sucer les pièces, ou passer un sachet vinyl sur la tête.



Von dem Zusammensetzen die Bauanleitung gut durchlesen. Kleber und Farbe nicht nahe von offenem Feuer verwenden und das Fenster von Zeit zu Zeit Belüftung öffnen. Bausatz von kleinen Kindern fernhalten. Verhüten Sie, daß Kinder irgendwelche Bauteile in den Mund nehmen oder Plastiktüten über den Kopf ziehen.



組み立てる前に必ず説明書をお読み下さい。接着剤や塗料をご使用の際は、窓を開けて十分な換気をおこない、火のそばでは使用しないで下さい。小さな子供の手の届かない所に必ず保管してください。部品や破片を噛んだり、なめたり、飲んだりすると大変危険です。又、部品を取り出した後のビニール袋は、小さな子供が頭から被ったりすると窒息する恐れがありますので、破り捨てして下さい。

INSTRUCTION SIGNS

* INSTR. SYMBOLY

* INSTRUKTION SINNBILDEN

* SYMBOLES

* 記号の説明



OPTIONAL
VOLBA
FACULTATIF
NACH BELIEBEN
選択する



BEND
OHNOUT
PLIER SIL VOUS PLAIT
BITTE BIEGEN
折る



OPEN HOLE
VYVRTAT OTVOR
FAIRE UN TROU
OFFNEN
穴を開ける



SYMMETRICAL ASSEMBLY
SYMETRICKÁ MONTÁŽ
MONTAGE SYMÉTRIQUE
SYMMETRISCHE AUFBAU
左右均等に組み立てる



NOTCH
ZÁŘEZ
L INCISION
DER EINSCHNITT
切る



REMOVE
ODRÍZNOUT
RETIRER
ENTFERNEN
移す



APPLY EXPRESS MASK
AND PAINT
POUŽIT EXPRESS MASK
NABARVIT

PARTS



DÍLY



TEILE



PIÈCES



部品

PLASTIC PARTS

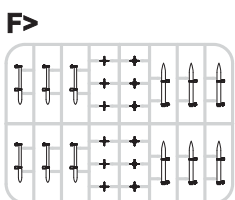
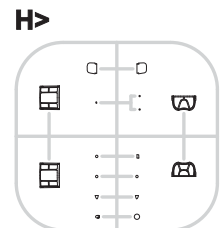
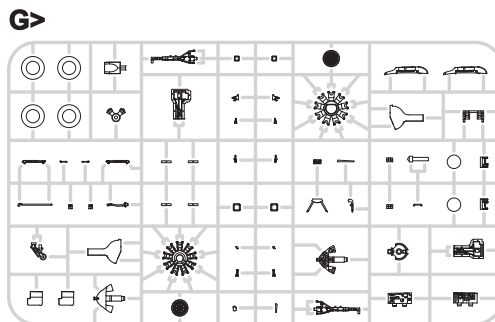
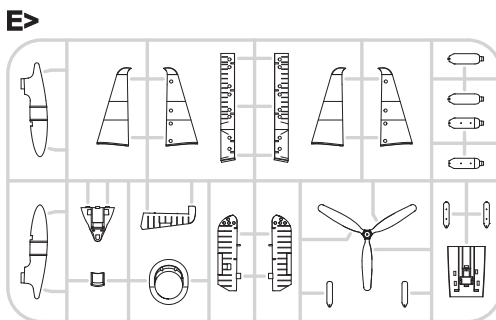
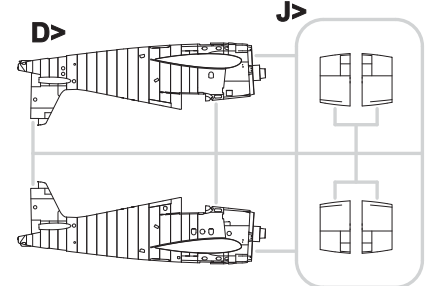
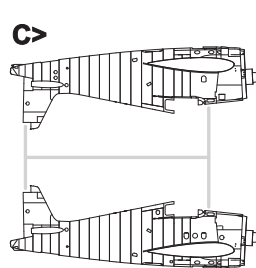

RP - RESIN PARTS

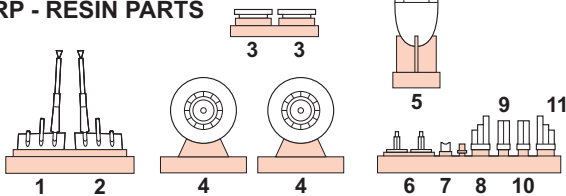
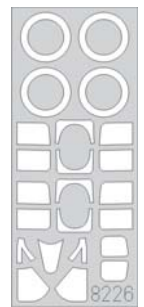
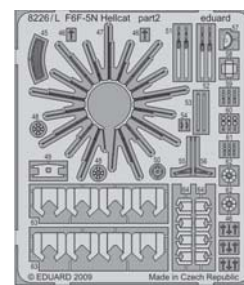
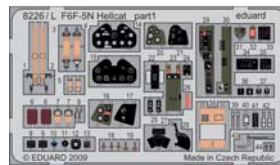
PE - PHOTO ETCHED
DETAIL PARTS

eduard
MASK

-Parts not for use. -Teile werden nicht verwendet. -Pièces à ne pas utiliser. -Tyto díly nepoužívejte při stavbě. - 使用しない部品

COLOURS



BARVY



FARBEN



PEINTURE



色

GSI Creos (GUNZE)		
AQUEOUS	Mr.COLOR	
H11	C62	FLAT WHITE
H12	C33	FLAT BLACK
H51	C11	LIGHT GRAY
H54	C14	NAVY BLUE
H58	C27	INTERMEDIATE GREEN
H77	C137	TIRE BLACK
H80	C54	KHAKI GREEN
H90	C47	CLEAR RED
H91	C48	CLEAR YELLOW

AQUEOUS	Mr.COLOR	
H94		CLEAR GREEN
H306	C306	GRAY
H316	C316	WHITE
H344		RUST
Mr.COLOR SUPER METALLIC		
	SM03	SUPER IRON
Mr.METAL COLOR		
	MC214	DARK IRON
	MC218	ALUMINIUM

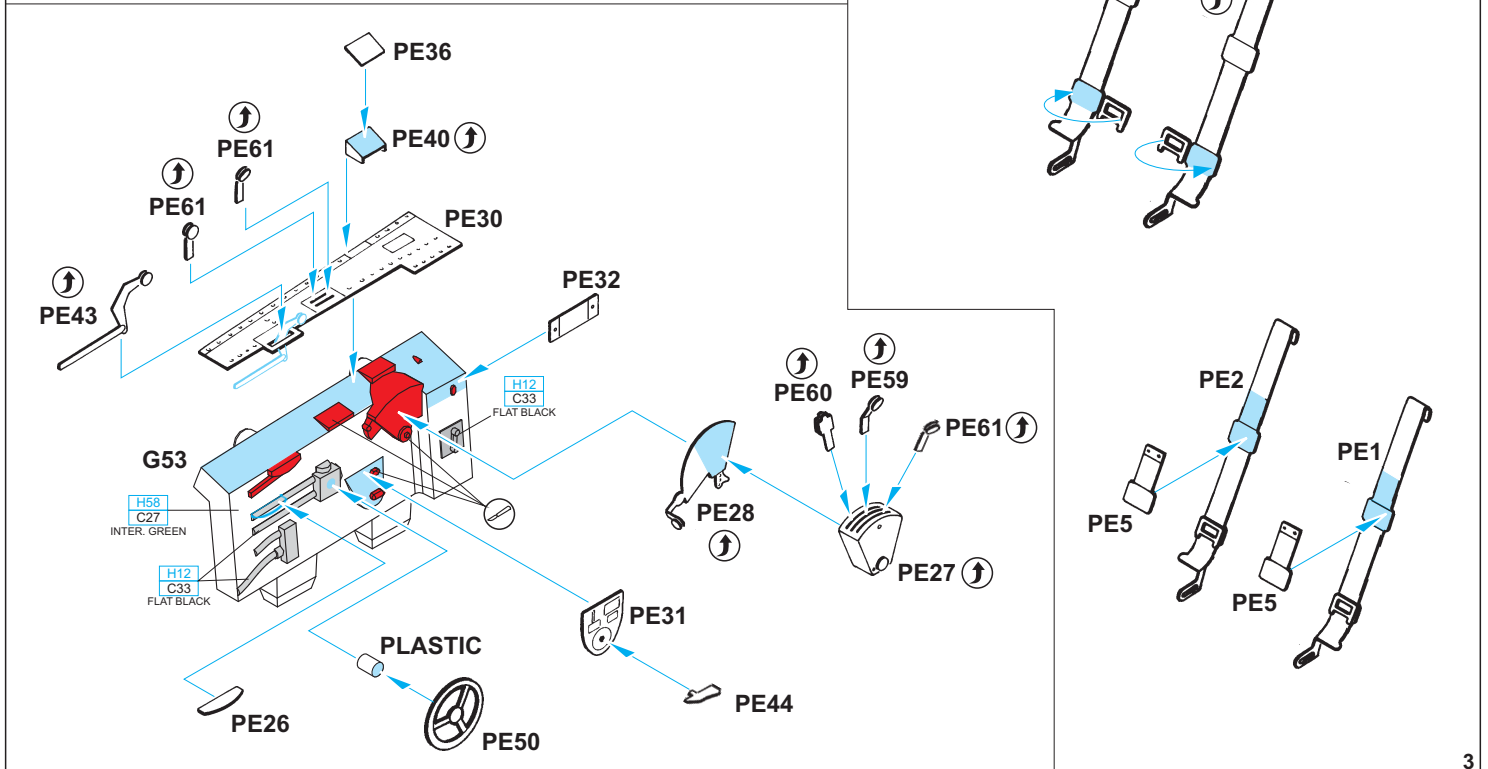
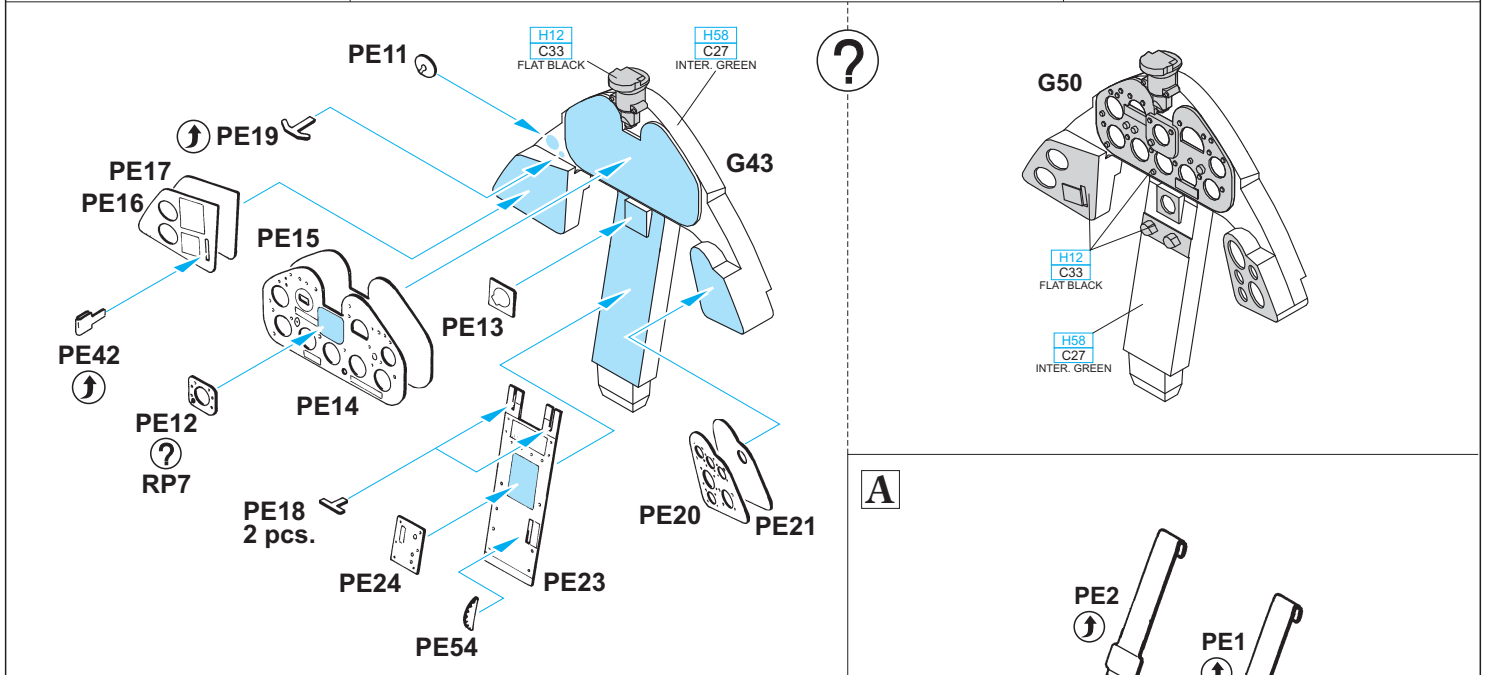
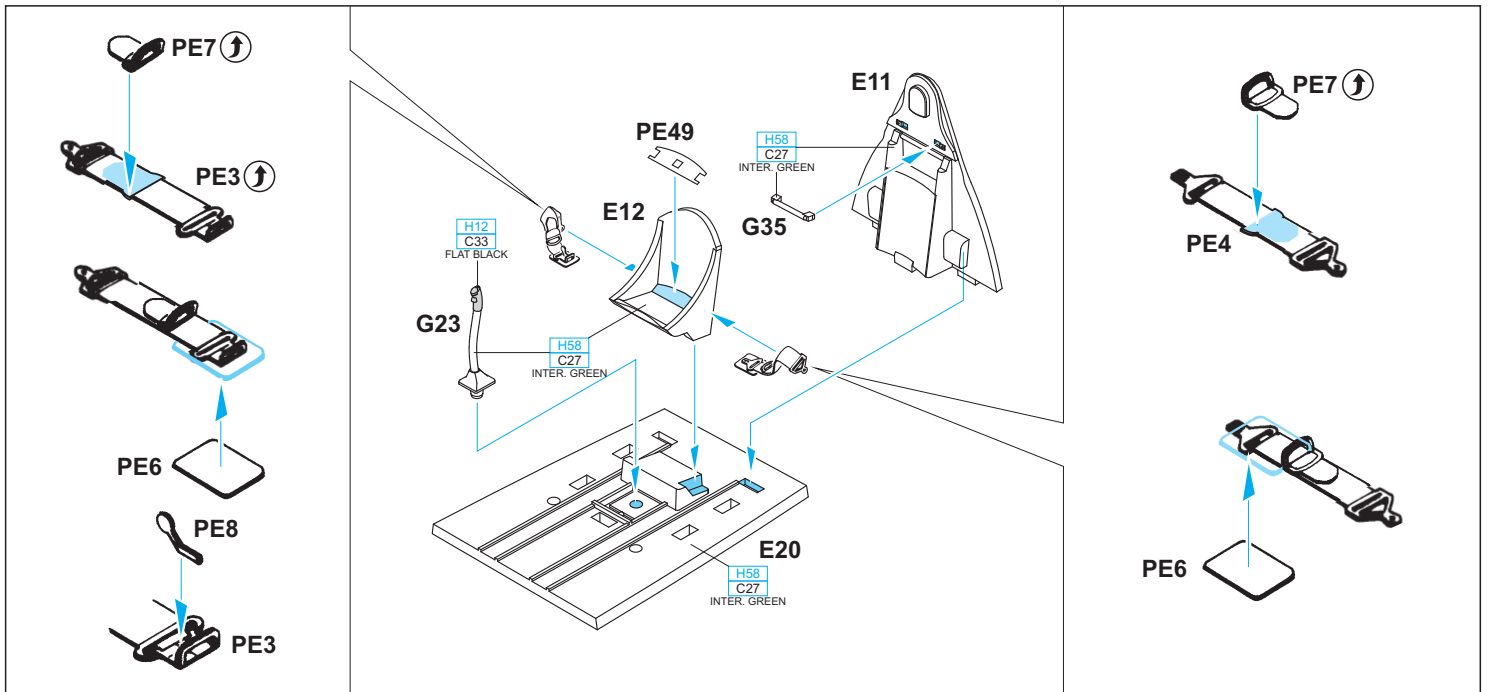

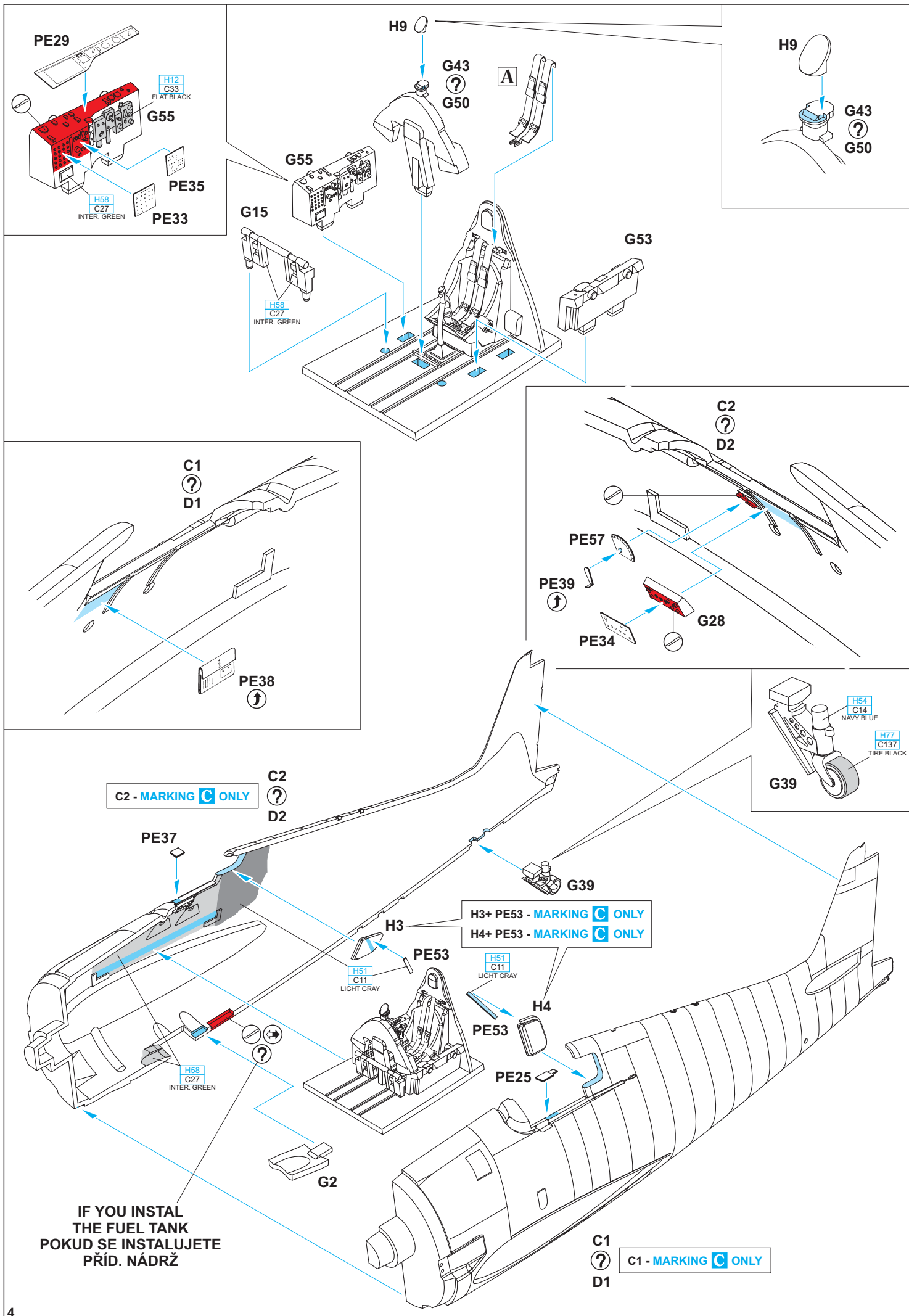

IF YOU INSTAL
THE FUEL TANK
POKUD SE INSTALUJETE
PŘÍD. NÁDRŽ

C1
D1
C1 - MARKING C ONLY

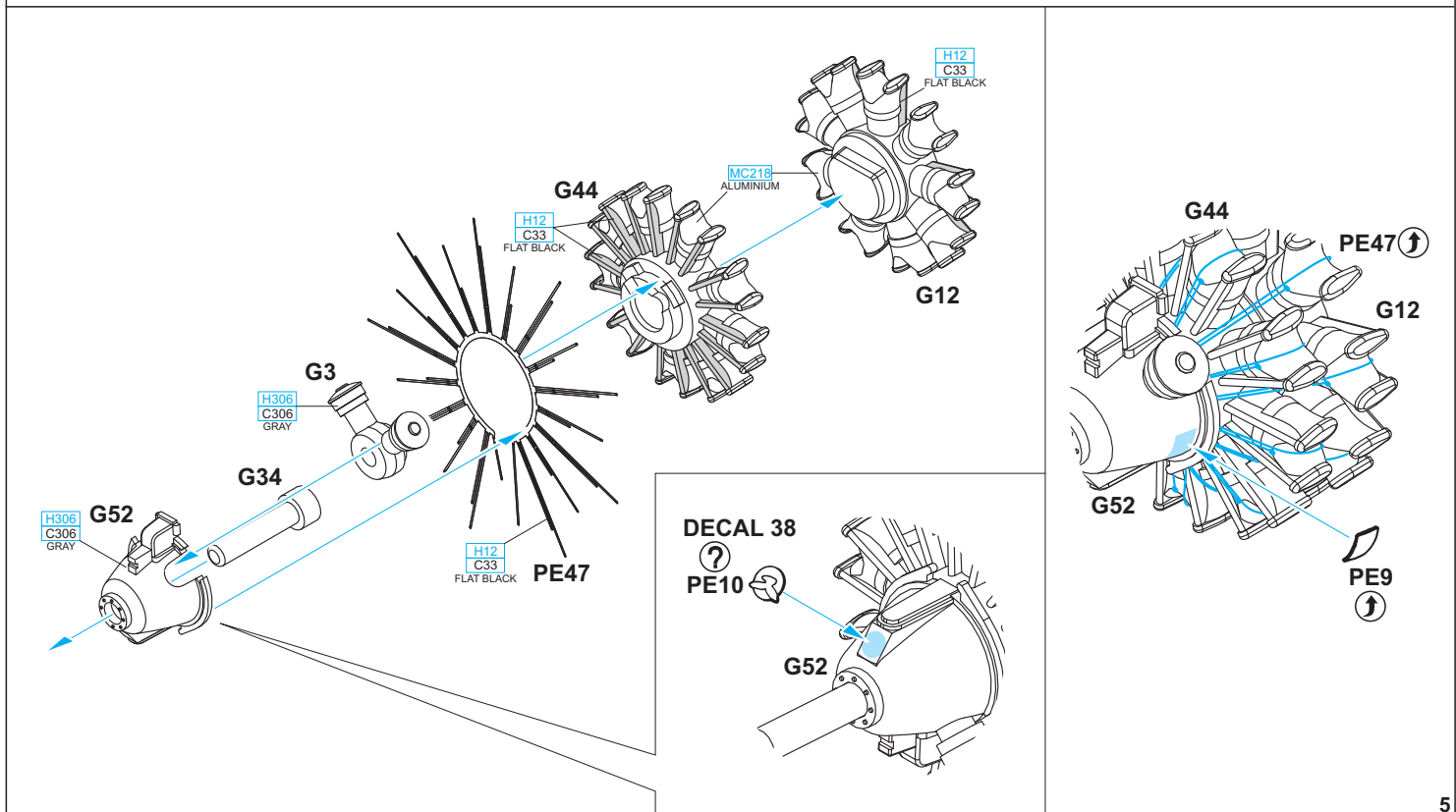
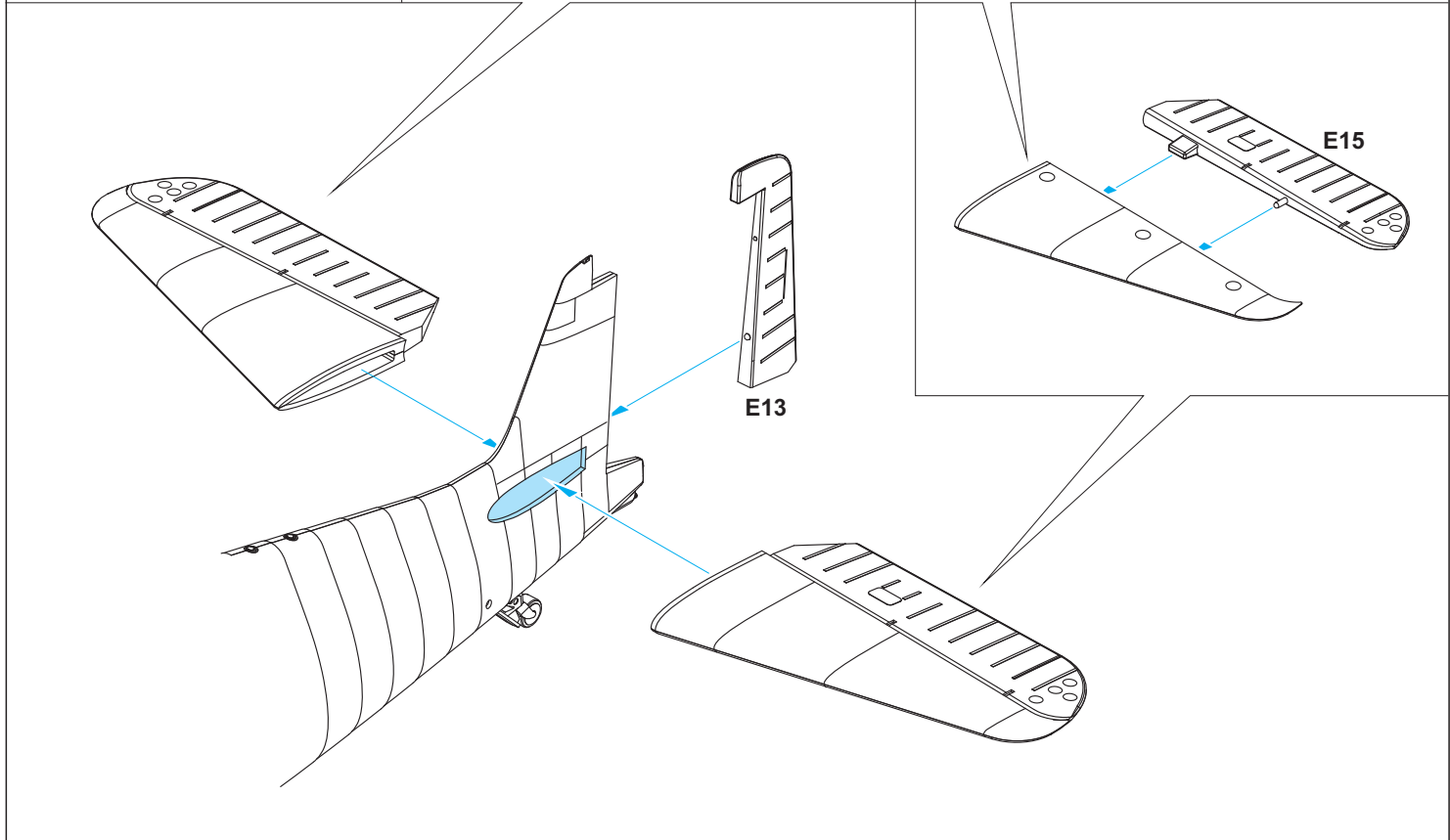
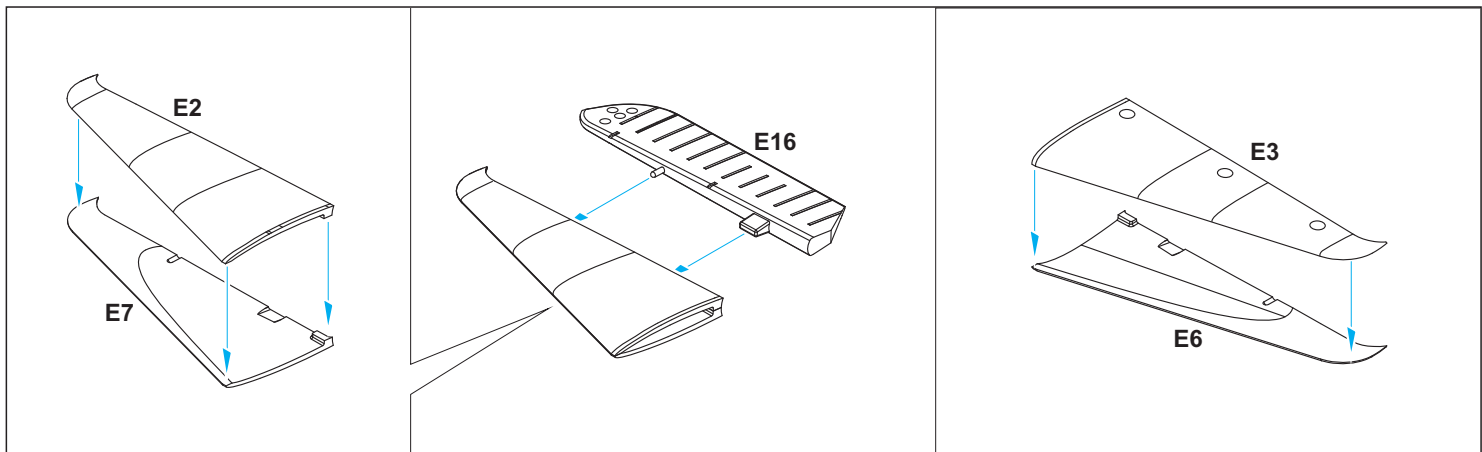

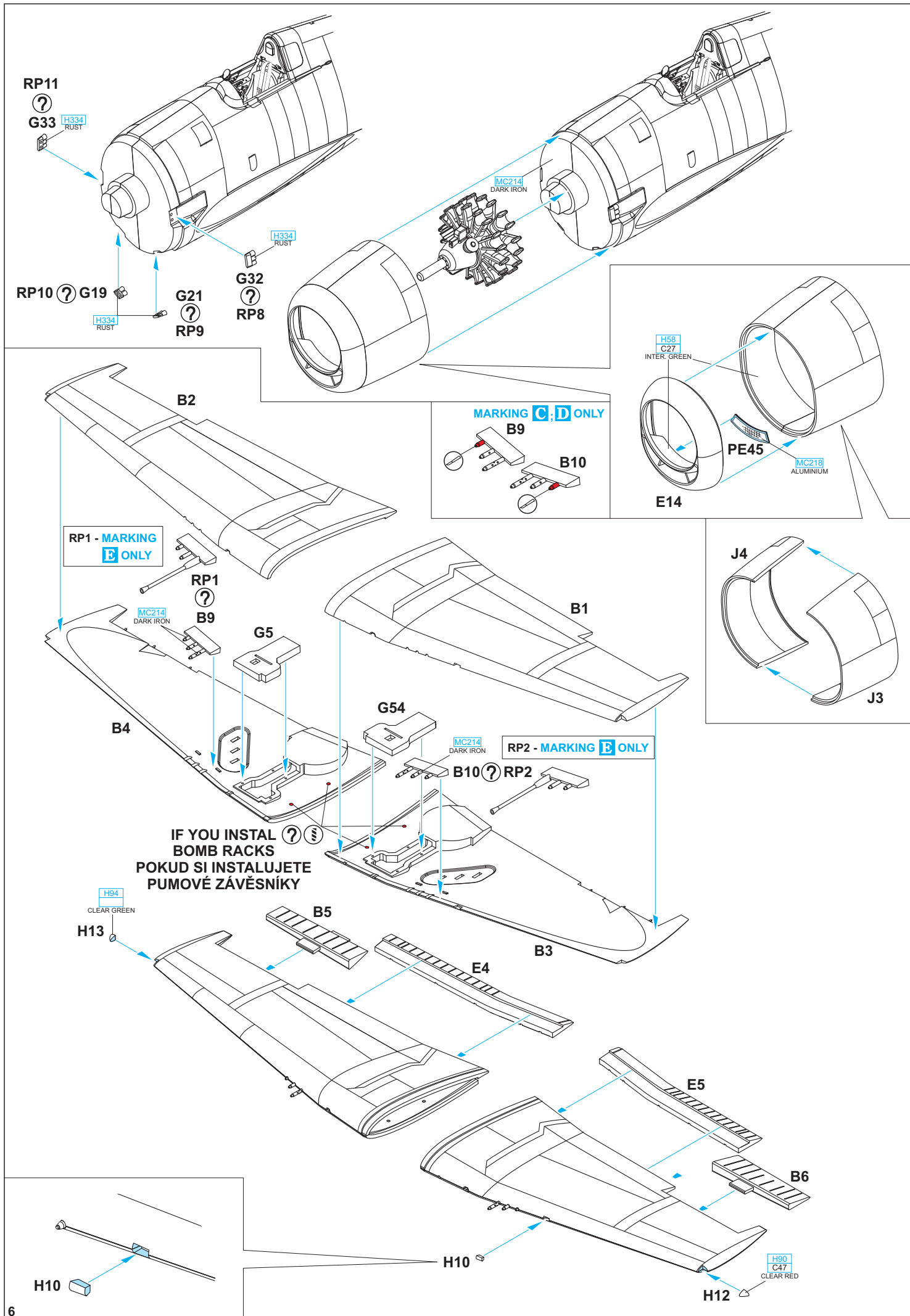

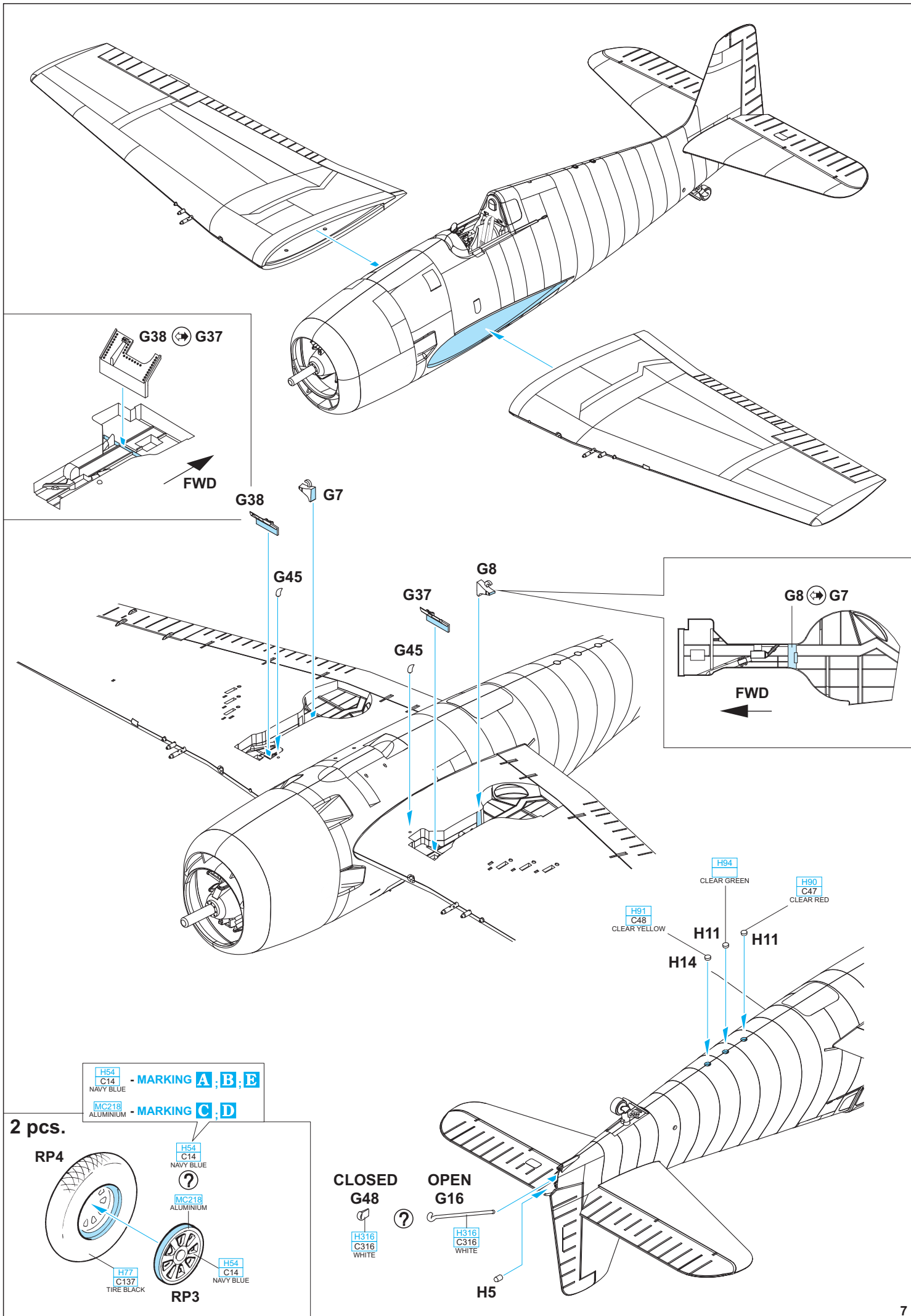

Undercarriage and wheel wells in lower surfaces color. Podvozkové šachty a nohy v barvě spodních ploch.

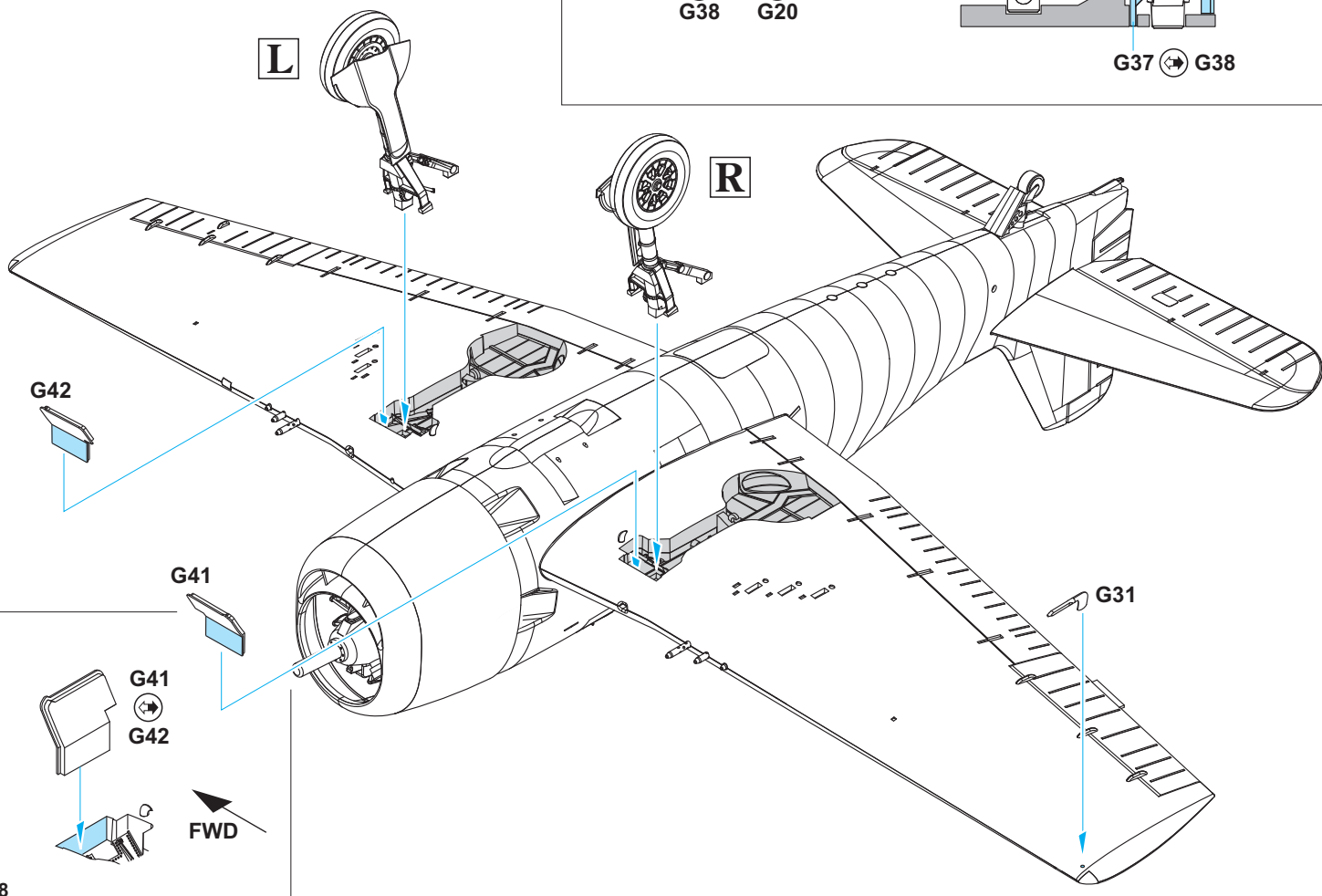
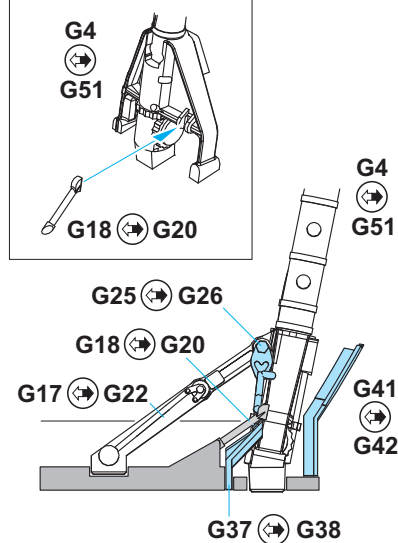
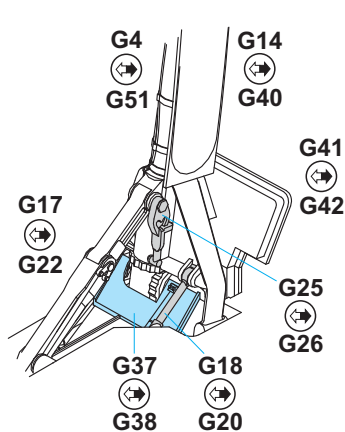
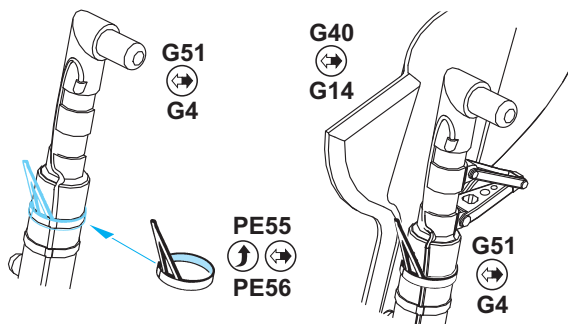
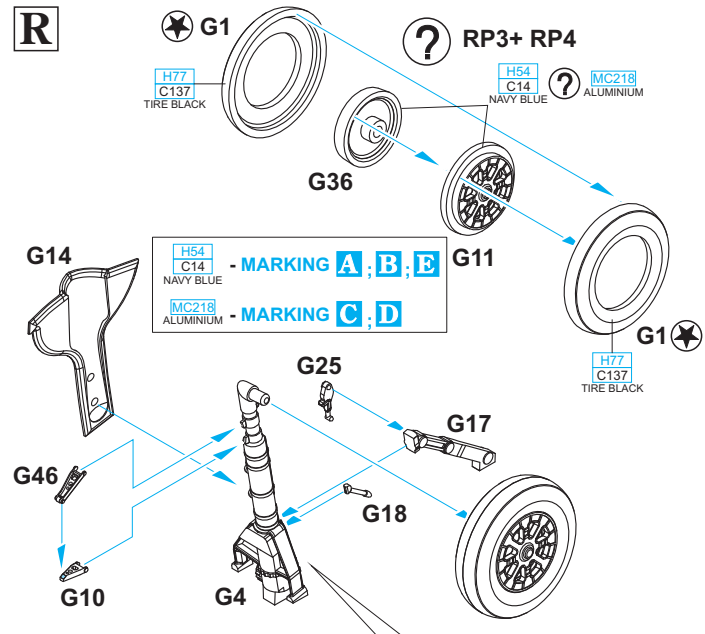
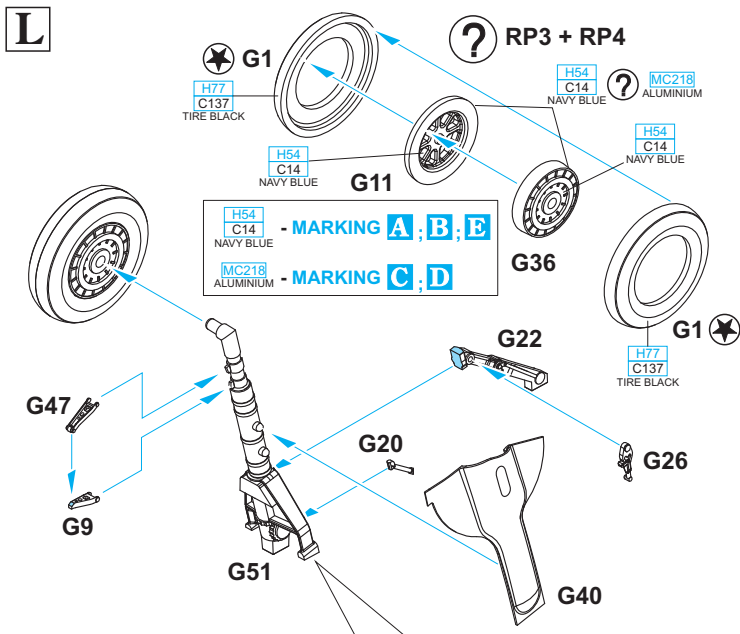

A MARKING **B**; **D** ONLY

6 pcs.

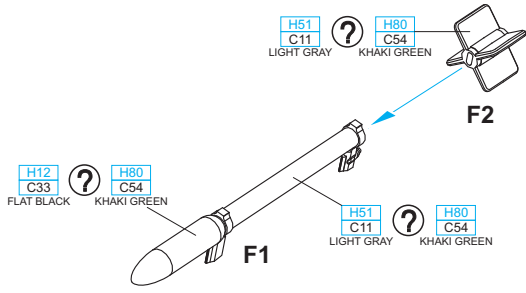

C

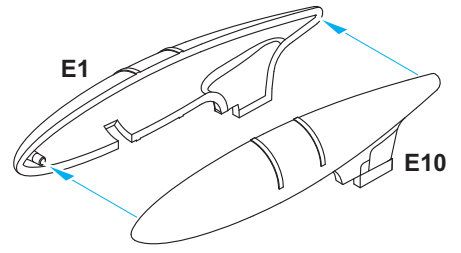

B MARKING **B**; **D** ONLY

6 pcs.

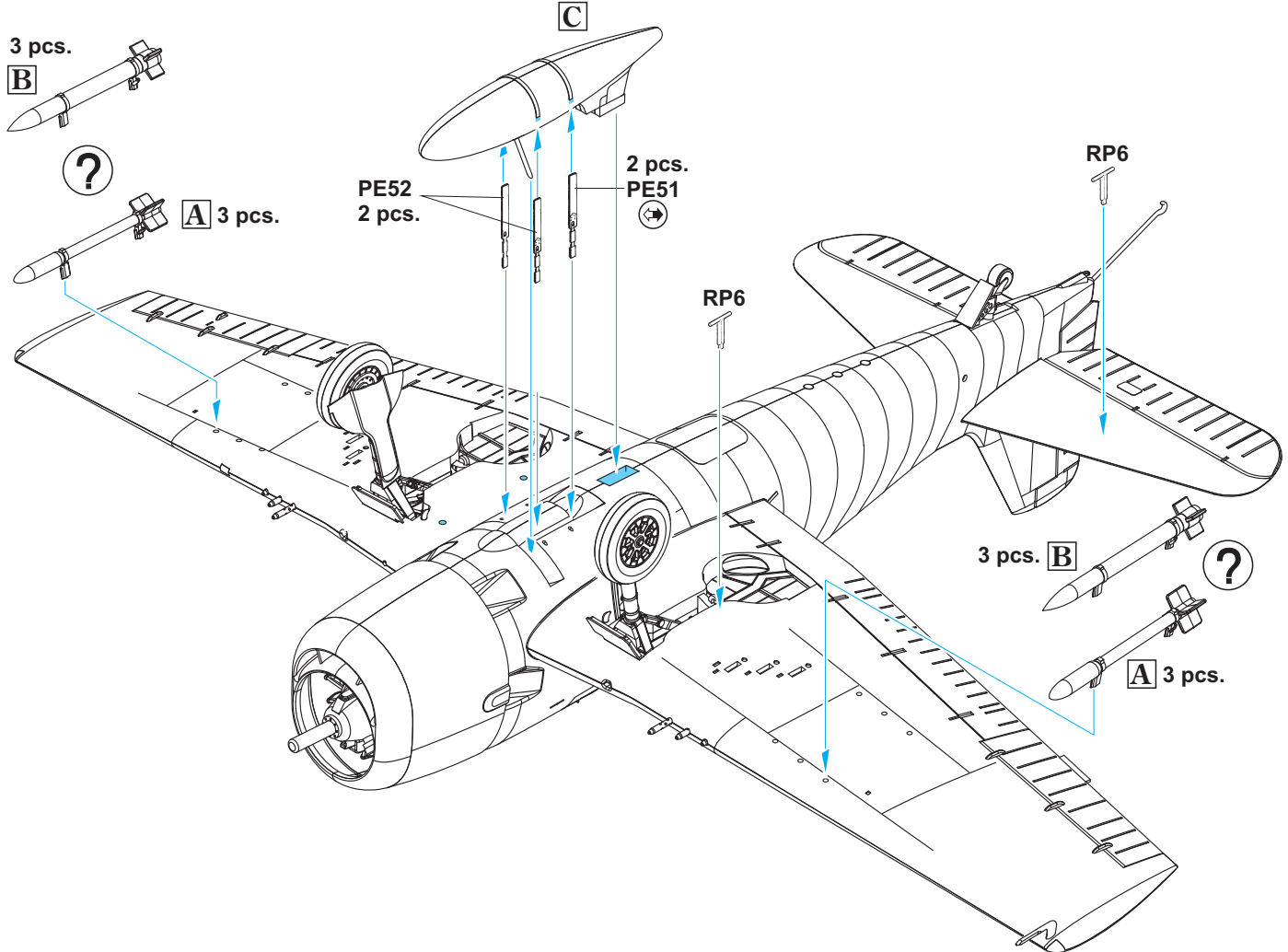
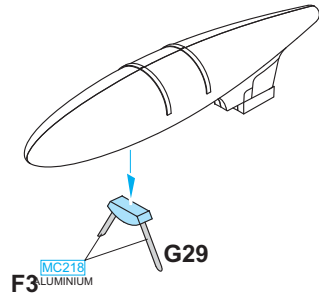
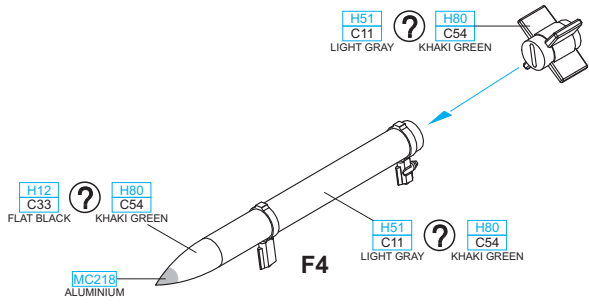

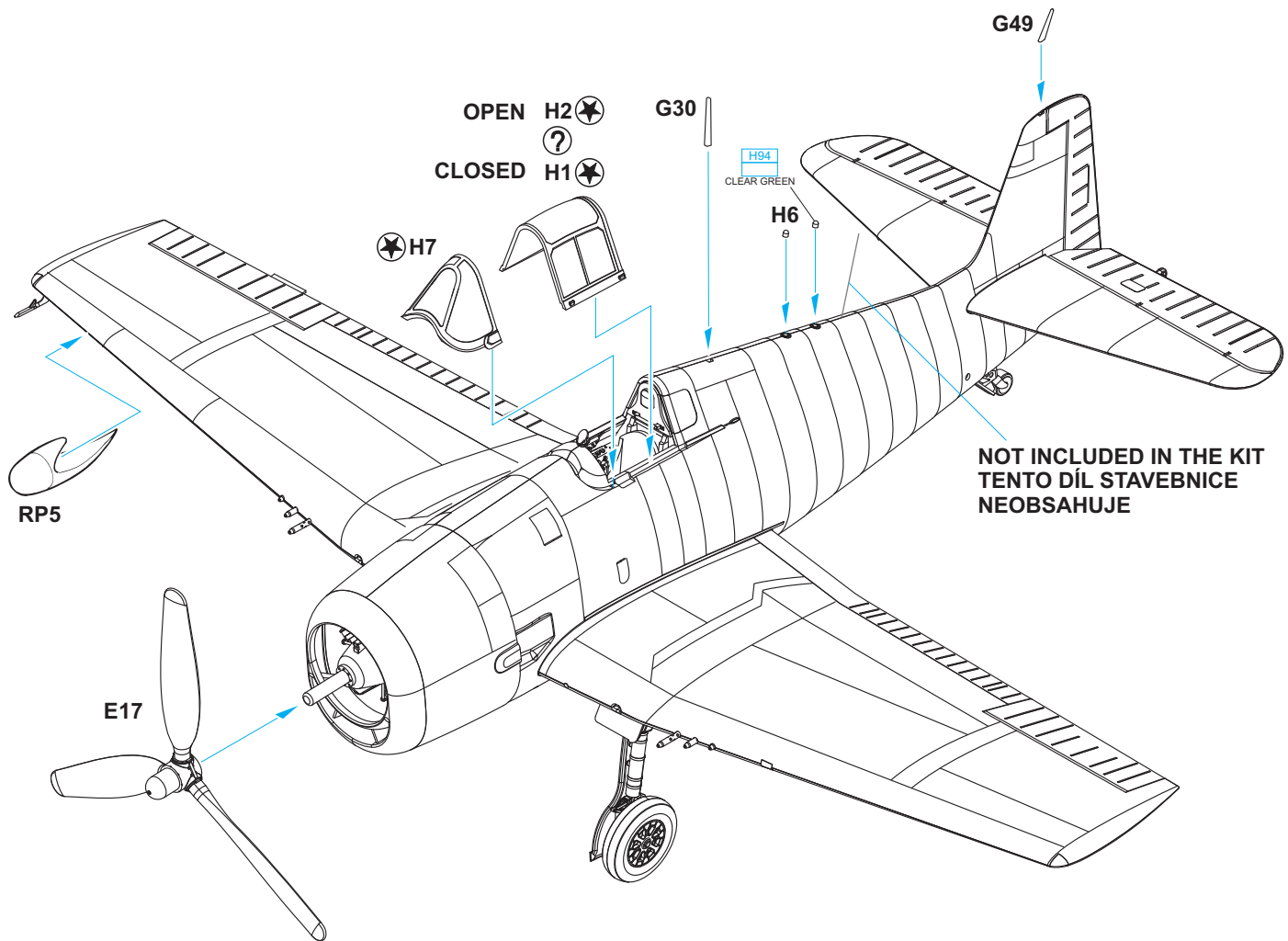

eduard
MASK

8226

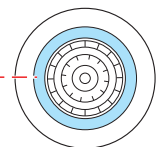
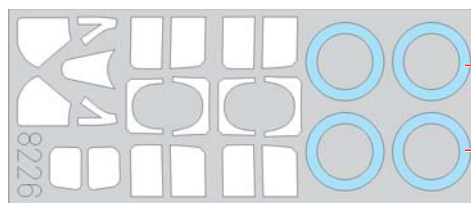

G1+ G36
2 pcs.

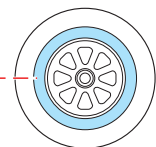

G1+ G11
2 pcs.

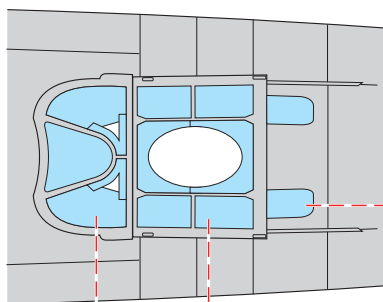
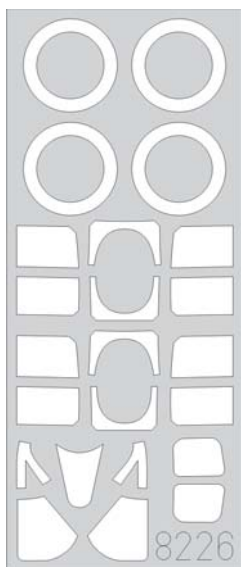

H3

H4

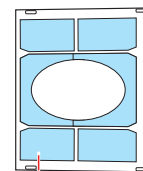

H2 - OPEN

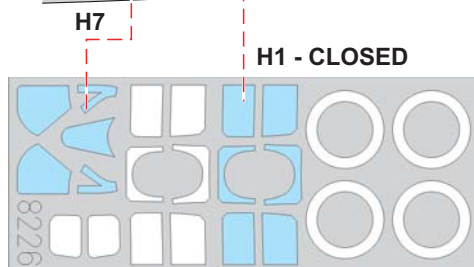

H1 - CLOSED

H7

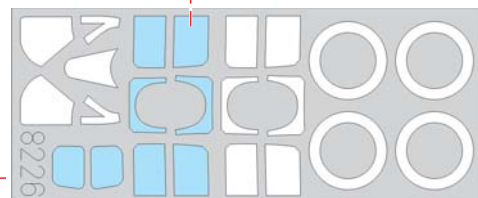

A VMF-511, USS Block Island, April 1945

USS Enterprise (CV-6) was damaged by two Kamikaze aircraft that hit water inches away from her hull on April 11, 1945. She carried CAG(N)-90 on her deck at that time. VF(N)-90, equipped with nightfighter Hellcats, was a part of this carrier air group. F6F-5N Hellcat 'White 24' rested on the flight deck at the time of the suicide attack and was damaged by flames. White arrow on the tail was carried by Big E aircraft from January 27, 1945 to July 27, 1945. VF(N)-90's first combat occurred on January 6, 1945. By May 14, 1945, when Big E was hit and badly damaged by Kamikazes yet again, the squadron downed 36 Japanese aircraft. After this date, Enterprise was forced to leave the combat zone and sail to the east for repairs.

Dne 11. dubna 1945 byla letadlové loď USS Enterprise (CV-6) zasažena výbuchy dvou japonských sebevražedných strojů. V té době nesla na palubě také noční leteckou skupinu CAG(N)-90. Její součástí byla i noční stíhací VF(N)-90. Hellcat „24“ byl během útoku Kamikaze zasažen plameny. Bílá šipka na ocasní ploše a křídle identifikuje letadla vzlétající z paluby Enterprise. Používána byla v období od 27. ledna 1945 do 27. července 1945. První bojové střetnutí prodělali letci VF(N)-90 dne 6. ledna 1945. Z paluby Enterprise působila tato jednotka až do 14. května 1945, kdy byla Big E opět zasažena Kamikaze a rozsáhlá poškození ji donutila odplout k opravám. Během této doby sestřelila 36 letadel.

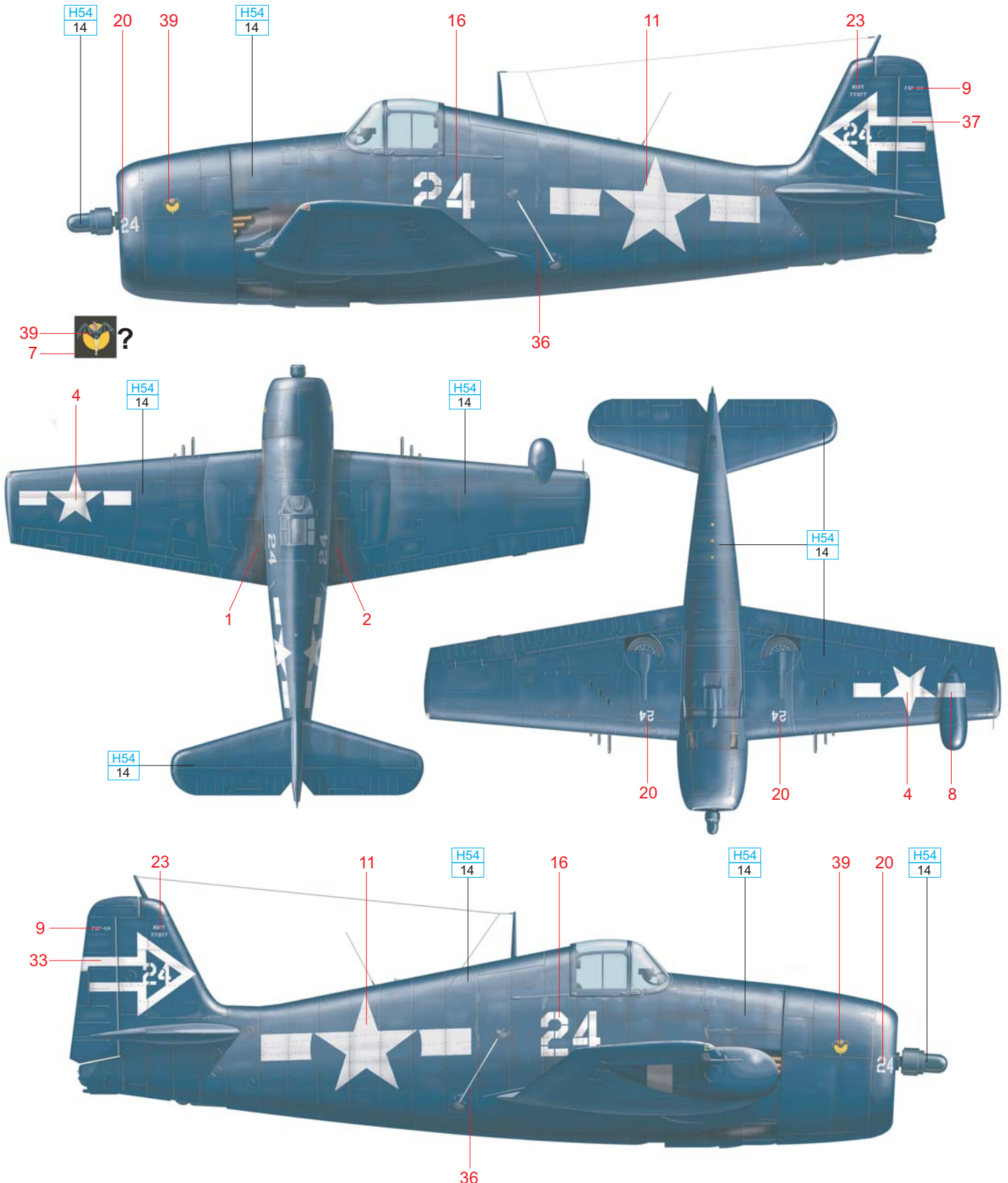

NAVY BLUE H54 14

eduard

B 'Butch', VMF-511, USS Block Island, April 1945

The first aircraft carrier to have a US Marine Corps nightfighter unit assigned to it was USS Block Island (CVE-106). VMF-511 embarked on Block Island in March, 1945, and was a mixed group of eight Corsairs, two photorecce F6F-5P Hellcats and eight F6F-5N Hellcat nightfighters. The squadron joined the battle for Okinawa on May 10, 1945 and was consequently sent to the eastern coast of Borneo to support landing operations at Balikpapan. The first and only success came on July 3, 1945 when 1stLt. Bruce Reuter shoot down an E13A „Jake“ floatplane. The Hellcat nicknamed 'Butch' was one of eight VMF-511 nightfighter Hellcats aboard Block Island. The White block with Blue 'I' is a carrier identification symbol, while the small Blue 'M' signifies the USMC. Black „I“ and „M“ are mentioned as Glossy Sea Blue in some sources.

První letadlovou lodí, která měla na palubě noční stíhací jednotku námořní pěchoty, se stala USS Block Island (CVE-106). Privilegovaným útvarem byla VMF-511, jejíž výzbroj tvořilo osm Corsairů, dva fotoprůzkumné Hellcaty a osm nočních stíhacích Hellcatů. Do bojů se zapojila 10. května 1945 u Okinawy, následně byla odeslána k podpoře vylodění v Balikpapanu na Borneu. Zde také dosáhla svého jediného sestřelu, když 1Lt. Bruce Reuter 3. července sestřelil plovákový E13A „Jake“. Jedním z osmi F6F-5N vzlétajících z paluby Block Islandu, byl stroj nesoucí jméno „Butch“. Bílý obdélník s černým „I“ byl symbolem strojů patřících na palubu Block Islandu. Malé černé „M“ značí stroj námořní pěchoty. Některé prameny uvádějí barvu písmen „I“ a „M“ na SOP jako Glossy Sea Blue.

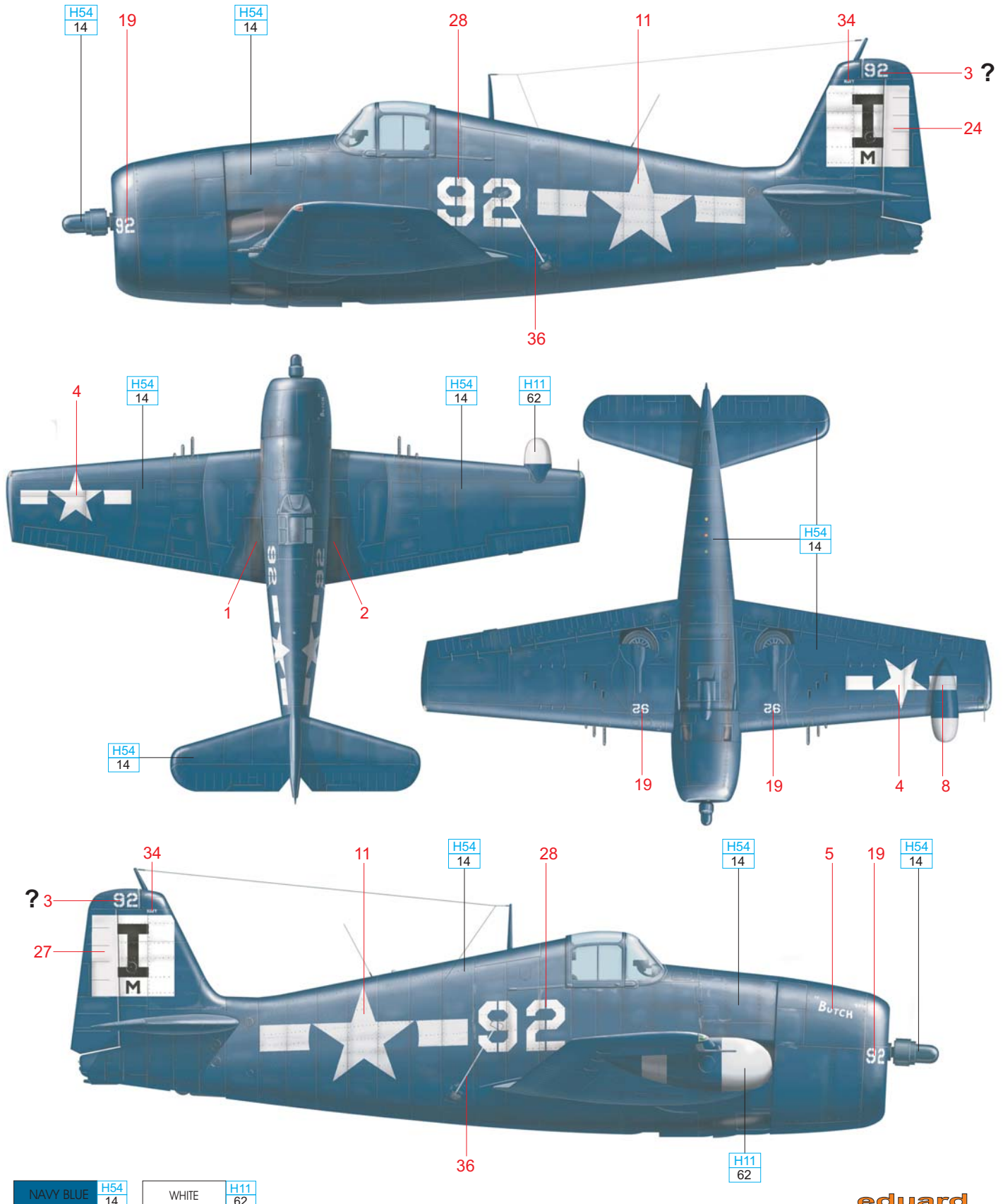

C VMF(N)-541, Falalop island, Ulithi Atoll, May 1945

Pin-up girls were not common on aircraft of the US Marine Corps. Exceptions existed on aircraft used by VMF(N)-541. This Marine Corps unit was equipped with Hellcat nightfighters and fought against Japanese air forces over Palau Islands and the Philippines. From May 30, 1945 on, the airfield at Falalop island became the new unit's home. From this airbase, the unit flew patrol missions over the US Navy's forward base at Ulithi Atoll. VMF(N)-541 aircraft were adorned with the combat name 'Bat Eye', despite the fact that bats don't use their eyes for night flying.

Pin-up girls, tedy malůvky spoře oděných slečen a dam, se na letadlech ve stavu americké námořní pěchoty objevovaly velmi výjimečně. Jednou z mála jednotek, která tuto praxi zdobení letounů tolerovala, byla VMF(N)-541. Tato jednotka, vyzbrojená nočními Hellcaty, prošla boji na souostroví Palau, zúčastnila se bojů na Filipínách, aby se v polovině ledna 1945 vrátila zpět na Peleliu (část Palau). V té době se pyšnila 23 sestřelenými stroji nepřítelů. Od 30. května 1945 se jejím domovem stalo letiště na ostrově Falalop, odkud se podílela na obraně kotviště v atolu Ulithi fungujícího jako předsunutá základna pro plavidla amerického námořnictva. VMF(N)-541 nesla bojové jméno Bat Eye, tedy Netopýří oko, i přesto, že netopýři k nočnímu lovu oči vůbec nepoužívají.

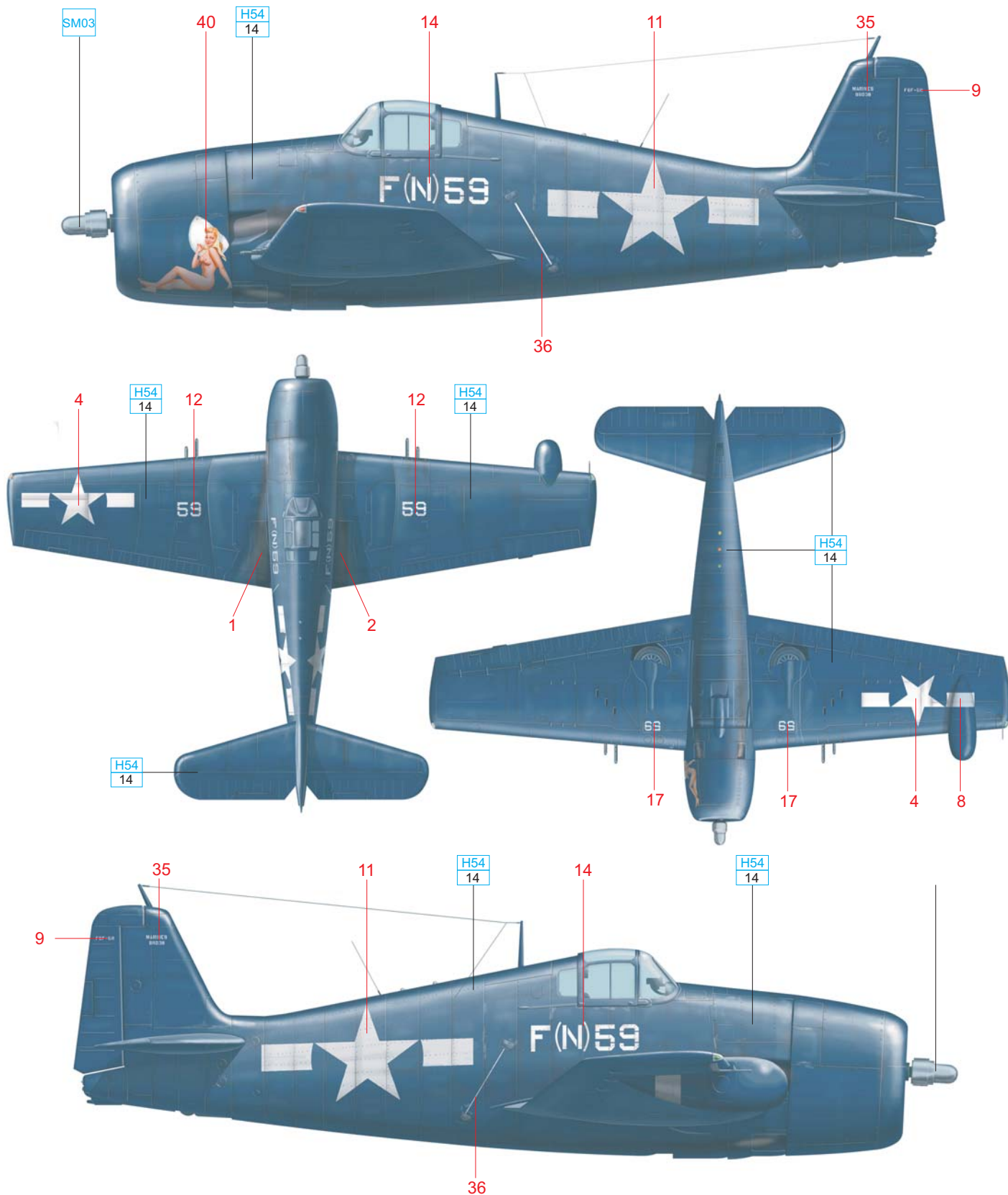

NAVY BLUE H54 14 SUPER IRON SM03

eduard

D BuNo. 72627 (??2827?), VMF(N)-533, Ie Shima, May 1945

VMF(N)-533 became one of the most successful Marine Corps squadrons as its pilots downed 35 enemy aircraft in the period from April to August 1945. 'Little Nance' belonged to this squadron and was photographed on Ie Shima island in May 1945.

Lt.Col. Marion Magruder, CO of VMF(N)-533, served in the Royal Air Force for a short period but learned a lot while flying the Bristol Beaufighter at that time. Magruder, nicknamed 'Black Mac', achieved one kill during WWII, shooting down a Betty bomber on June 22, 1945. Another famous pilot within VMF(N)-533 was Capt. Robert Baird, who is the only nightfighter and Hellcat WWII ace serving with the Marine Corps. He shot down six Japanese aircraft in June and July, 1945. The squadron's combat name was 'Crystal Gazers', and its aircraft carried black codes instead of the common white ones.

VMF(N)-533 se stala jednou z neúspěšnějších jednotek amerického námořního letectva, když v období od dubna do srpna 1945 sestřelila celkem 35 nepřátelských letadel.

„Little Nance“ byla jedním z jejích strojů, které používala během svého působení na ostrově Ie Shima. Jednotce velel LtCol. Marion Magruder, veterán se zkušenostmi v Royal Air Force, jenž přispěl k celkovému skóre jednotky jedním sestřeleným bombardérem Betty v noci 22. června 1945.

V řadách VMF(N)-533 se zrodilo také jediné noční stíhací eso námořní pěchoty. Stal se jím Capt. Robert Baird se šesti sestřely. VMF(N)-533, nesoucí bojové jméno „Crystal Gazers“, používala na rozdíl od ostatních jednotek USMC černé trupové označení letadel.

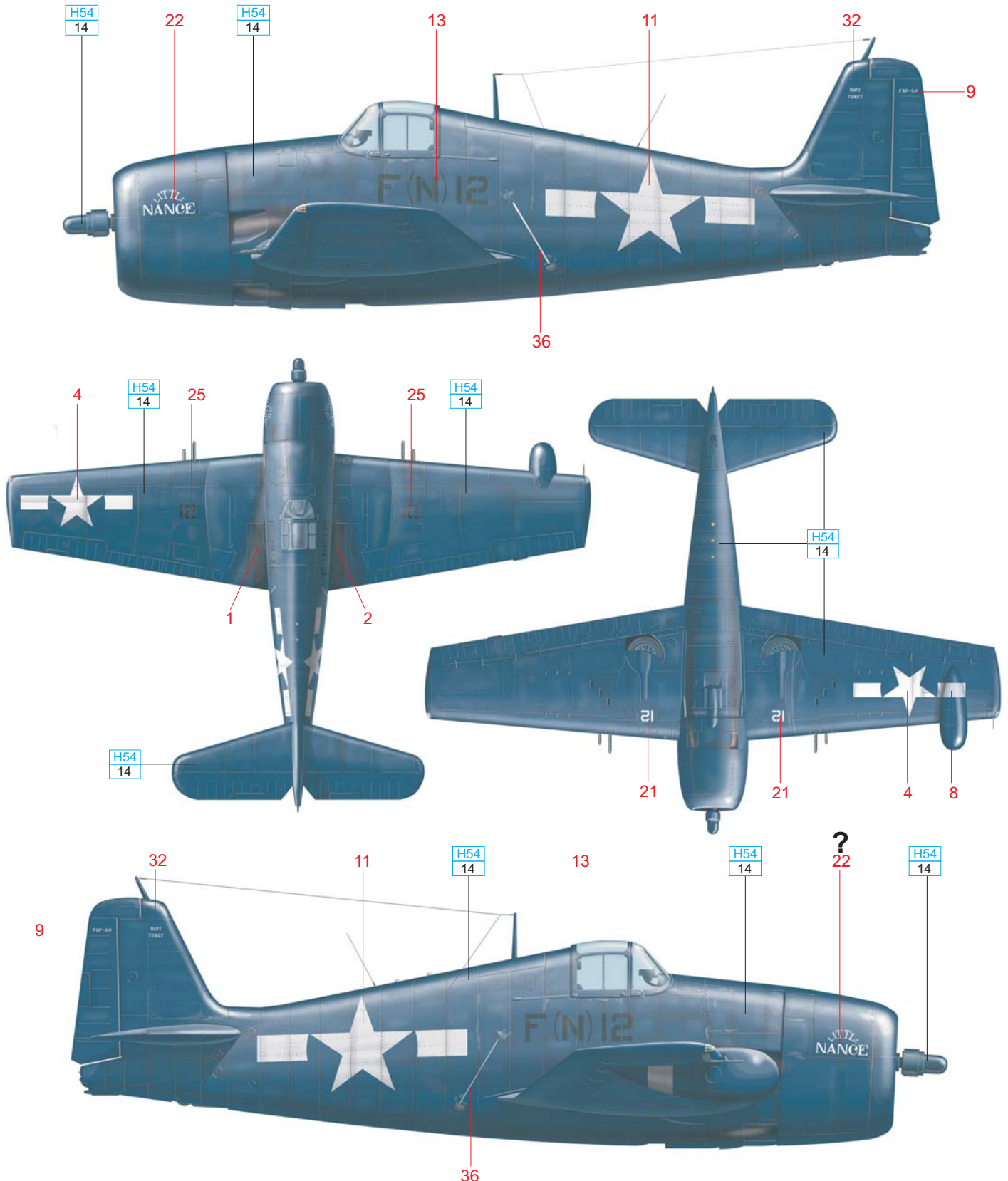

NAVY BLUE H54
14

eduard

E BuNo. 78669, Maj. Bruce Porter, CO of VMF(N)-542, Yontan airfield, Okinawa, May 1945

Hellcat BuNo. 78669 was the personal mount of five kill ace Maj. Bruce Porter, Commanding Officer of VMF(N)-542. He inherited this F6F-5N from his predecessor. The Hellcat carried a big red heart and the white name 'Millie Lou' on the nose. Porter ordered his ground crew to overpaint it immediately after his arrival and a big bottle of Schenley's whiskey and 'Black Death' in white appeared in its place. Porter downed three Zeros in June/July 1943 over the Solomons while serving with VMF-121. On June 15, 1945 he added two more to his tally, shooting down a Kawasaki Ki-45 'Nick' heavy fighter and a 'Betty' bomber carrying an Ohka suicide rocket plane.

Major Bruce Porter, eso s pěti sestřely na kontě, používal Hellcat BuNo. 78669 jako svůj osobní stroj. Zdědil jej po svém předchůdci na postu velitele VMF(N)-542 a ještě v den svého nástupu do funkce, 23. května 1945, nechal přestříkat stávající kresbu na přední představující velké červené srdce a bílým nápisem Millie Lou. Místo ní se na pravé straně motorového krytu objevila láhev bourbonu Schenley a nápis Black Death. Porter dosáhl svých prvních sestřelů ještě jako pilot Corsairu v červnu a červenci 1943 u VMF-121, kdy si v boji nad Šalamounovými ostrovy připsal tři vítězství. Zbylé dva sestřely, které mu daly možnost zařadit se mezi stíhací esa, dosáhl 15. června 1945 právě v kokpitu tohoto Hellcatu. Nárokoval sestřelení dvoumotorové stíhačky Kawasaki Ki-45 „Nick“ a bombardéru „Betty“ s podvěšenou sebevražednou Ůkou, k boji došlo u pobřeží Okinawy. Malé vlaječky symbolizující sestřely se nacházely pouze na levé straně trupu pod kabinou.

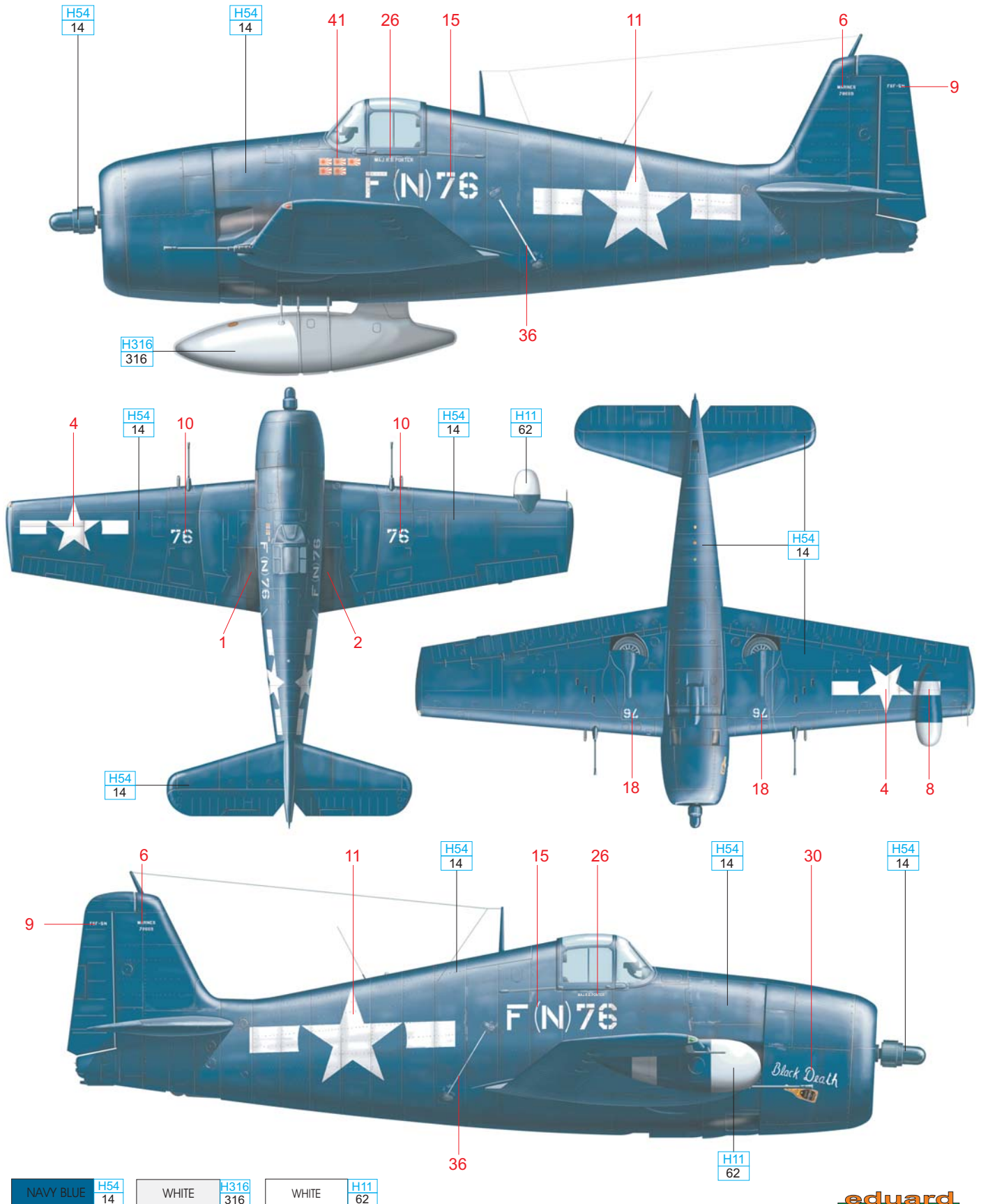

NAVY BLUE	H54 14	WHITE	H316 316	WHITE	H11 62
-----------	-----------	-------	-------------	-------	-----------

