

## F-15 C or E "Eagle" Saudi-Arabia Air Force: 89<sup>th</sup> anniversary scheme

For 1/72 kits of F-15C or F-15E Strike Eagle

### HISTORY

Saudi Arabia took delivery of over 100 F-15C/Ds from 1982 to 1990 under the "Peace Sun" contract fitted with F100-PW-229 engines.

The F-15S is a variant of the F-15E Strike Eagle of which over 70 were supplied to the Royal Saudi Air Force (RSAF) in the 1990s. They were delivered fitted with P&W F100-PW-229 engines.

End 2011 an additional 84 F-15SA were ordered including an upgrade program for existing F-15S to SA standard. The engine type is F110-GE-129.

The total current Saudi fleet of F-15's are some 60 F-15C, 20 F-15D and over 150 F-15S(A).

The Saudi National Day is celebrated every September and commemorates the renaming of the Kingdom of Nejd and Hejaz to the Kingdom of Saudi Arabia by a royal decree from King Abdul Aziz Ibn Saud in 1932.

As part of the 89<sup>th</sup> year celebrations in 2019, the Royal Saudi Air Force painted some combat aircraft like F-15 Eagles, Eurofighter Typhoon and Tornado IDS in special liveries with on the tails silhouettes of the Saudi rulers.

The special scheme was seen on both Saudi F-15C fighter (upper jet in photo) and F-15SA Strike Eagle (lower jet in photo).

Note that the F-15S has some asymmetric ECM fairings.

### DECAL SYSTEM

The decal sheet has one continuous print film, so each decal needs to be cut out with fine scissors.

No other prior decal preparation is needed. Each cut out decal can be applied as usual after soaking it a short while in water.

Decals are VERY THIN, so slide off from the wet backing sheet on a horizontally held GLOSSY model surface.

Note that a decal that contains a white section is often split in two parts. To get the full decal marking, apply both. On the decals sheet you will often see an "arrow" to indicate this way of application.

After all decals have been applied, finish the model with your preferred final gloss, matt or semi-matt varnish coats. This will also protect all the decals.



The Saudi F-15 C/D colours upon delivery were in "Ghost grey" schemes of FS36375 with FS36320 patterns. Current F-15SA colours are "Mod Eagle" FS36251 with FS36176 patterns.

Large VISION markings are situated on the insides' of the tails. Note "hawk" patterns on fuselage (A)

in front of the intakes and external fuel tanks (G).

All are provided as decals. The decals on the intakes (B)(C) may need some trimming.

Some low vis stencils may have been applied and can be obtained from the kit decal sheet.

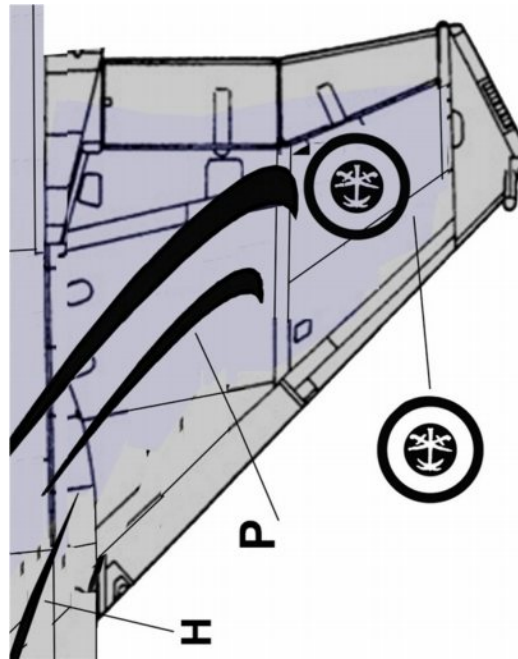
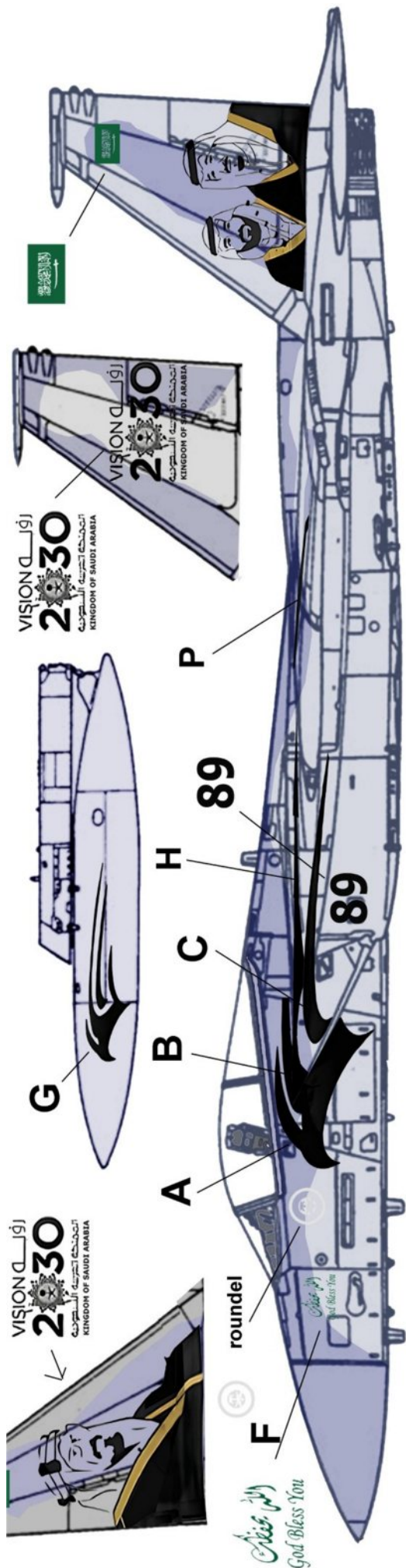

F-15C scheme , upper wing

### < F-15C scheme

Scheme of F-15S(A) Strike Eagle is similar.

Scheme is symmetrical port and starboard.

On the upper wing are black swirls "P" and these are provided as decals.

NOTE: some artist impressions show another swirl pattern but on the actual F-15's these were applied differently.

Trim swirl line "H" to correct length, it runs on upper surfaces from intake to wing. Swirls "B" and "C" are on the vertical intake sides.

The roundels on the nose are in light grey.

On both port and starboard wing tips a large black wing roundel is present. Probably on the lower wing NO roundels are present. But some are provided.

Please visit website: [www.aircraftinplastic.com](http://www.aircraftinplastic.com)



© copyright 2024