

ALBATROS D-III

Revell

H-74-380

PRINTED IN ENGLAND

Speedy, streamlined and, in general, a very good looking aircraft, the Albatros D series of fighters sprang from a pre-war racing design by engineer Robert Thelen. One of the most significant of these fighters was the D-III version. Its fuselage was plywood covered like those of the D-I and D-II, but a different set of wings was fitted. Every attention was paid to streamlining and the D-III was possessed of quite a respectable performance for its time. This racy little fighter was piloted by many a famous German ace and it provided the beginnings of such careers as those of Von Richtofen, Voss, Göring and Udet. It was only a stepping stone, for as more

advanced types such as the D-V, Fokker Dr I and D-7 became available, the D-III was handed down to those pilots not having yet made their reputation.

Specifications

Span: 29'8"
 Length: 24'
 Weight: 1,454 lbs. empty, 1,949 lbs. loaded
 Power: 160 hp Mercedes D-III straight six
 Armament: 2-7.92 mm Spandau Maxim M.G.s
 Top Speed: 103 mph

GET YOUR TOOLS READY:

★ ★ ★ BEFORE YOU BEGIN ★ ★ ★

FIRST, FIT PARTS TOGETHER and TRIM EXCESS PLASTIC. Use a toothpick, pin or small paint brush to apply cement. APPLY CEMENT SPARINGLY. Too much cement will damage your model.

If you wish to stop at any point during the construction of your model do so at the end of an Assembly Step.

NOTE: In the illustrations some of the details on the parts have been OMITTED FOR CLARITY.

IF YOU WISH TO PAINT YOUR MODEL — See PAINTING FLAGS  for color suggestions.

- Use paints made for plastics only.
- Paint small parts before detaching from runner.
- Start with the lighter colors.
- Scrape off paint where cement is to be applied. Cement will not work on paint.

1 FUSELAGE ASSEMBLY

You have the choice of assembling this model as one of the three versions shown on the back of this sheet. Decide which version to build before you start. The DECALS supplied will complete any one of the three PLANES. Paint the large parts; FUSELAGE, WINGS and TAIL SURFACES and allow paint to dry before you start assembly.

- | | |
|-------------------------|-------------------------|
| 1 PROPELLER | 6 LOWER WING |
| 2 PROPELLER RETAINER | 7 HORIZONTAL STABILIZER |
| 3 PILOT | 8 ENGINE |
| 4 FUSELAGE — RIGHT HALF | 9 MACHINE GUNS |
| 5 FUSELAGE — LEFT HALF | |

1. CAREFULLY cement (1) to (2).
2. Cement (3) to (4).
3. LOCATE, DO NOT CEMENT THE PROPELLER to (4). Cement (5) to (4). DO NOT LET CEMENT TOUCH PROPELLER OR IT WILL NOT ROTATE.
4. Cement (6) and (7) to FUSELAGE.
5. Cement (8) and (9) to FUSELAGE.

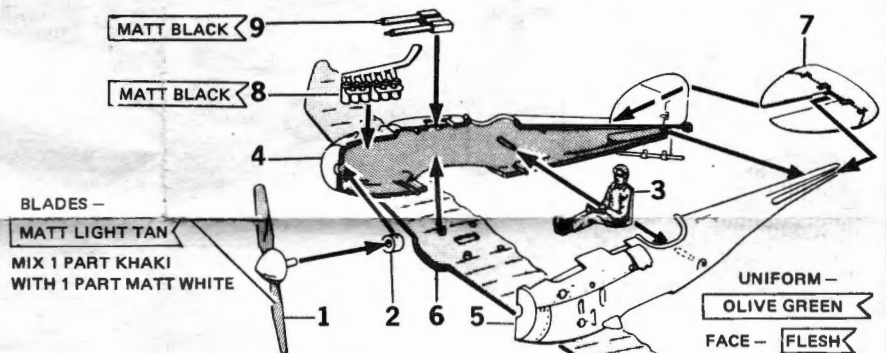

2 WING TO FUSELAGE

- | | |
|-----------------------------|-----------------------|
| 10 OUTER WING STRUT — RIGHT | 14 UPPER WING |
| 11 OUTER WING STRUT — LEFT | 15 WATER LINE — SHORT |
| 12 INNER WING STRUT — RIGHT | 16 WATER LINE — LONG |
| 13 INNER WING STRUT — LEFT | |

1. Cement (10), (11), (12), and (13) to bottom of (14).
2. Cement WING STRUTS to LOWER WING and to FUSELAGE.

SEE DETAIL "A"

1. Cement (15) to FUSELAGE and rear locator in bottom of UPPER WING.
2. Cement (16) to forward locator in WING and front of ENGINE.

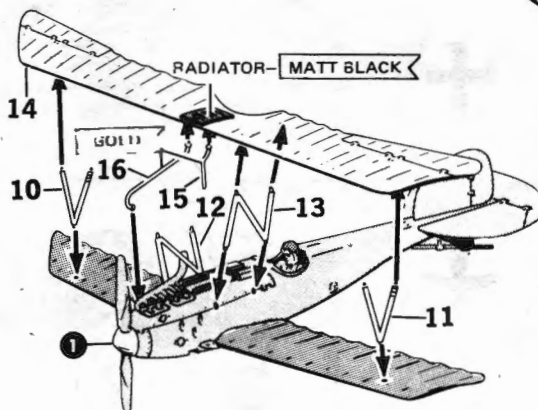

3 FINAL ASSEMBLY

- | | |
|-------------------------------|---------------------------|
| 17 LANDING GEAR STRUT — RIGHT | 20 WHEEL & TIRE (2 Parts) |
| 18 LANDING GEAR STRUT — LEFT | 21 WHEEL — DISC (2 Parts) |
| 19 LANDING GEAR AXLE | |

1. Cement (17) and (18) to (19). NOTE: SMALL TUBE ON (19) MUST BE TO THE REAR.
2. LOCATE, DO NOT CEMENT, one (20) on each AXLE. CAREFULLY cement one (21) to each end of AXLE, DO NOT LET CEMENT TOUCH PARTS (20) OR WHEELS WILL NOT ROTATE.
3. Cement LANDING GEAR ASSEMBLY to the FUSELAGE.
4. See 3-VIEW DRAWINGS for additional PAINTING and DECAL placement.

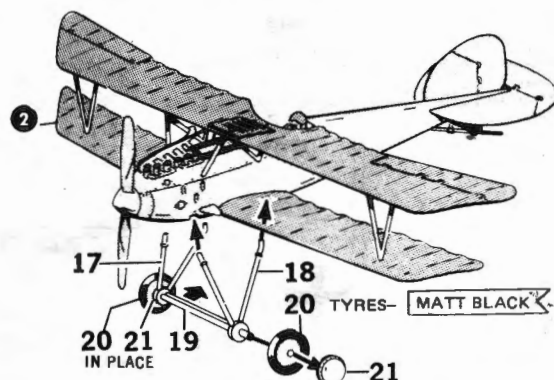

Baron Von Richtofen's D-III

MATT DARK PURPLE
MIX 1 PART MATT SCARLET
WITH 3 PARTS MATT BLUE

MATT LIGHT BLUE
MIX 1 PART MATT BLUE
WITH 1 PART OLIVE GREEN
AND 20 PARTS MATT WHITE

MATT LIGHT TAN
MIX 1 PART KHAKI
WITH 1 PART MATT WHITE

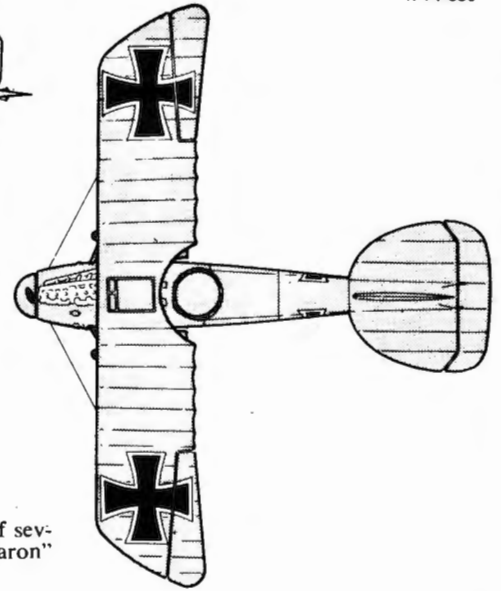
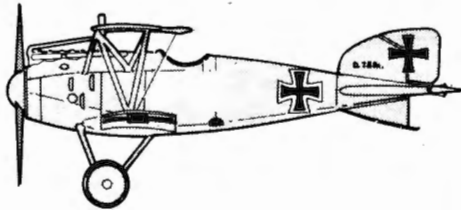
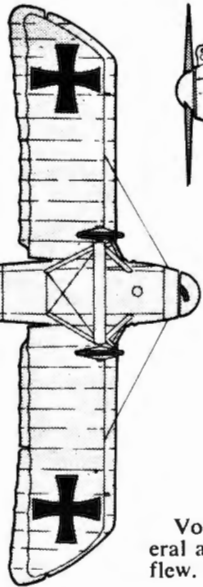

MATT SCARLET
F.S. 31136

Von Richtofen's all red Albatros was one of several aircraft of varying types that the "Red Baron" flew.

Werner Voss's D-III

SEE TOP OF PAGE
FOR COLOUR MIXES

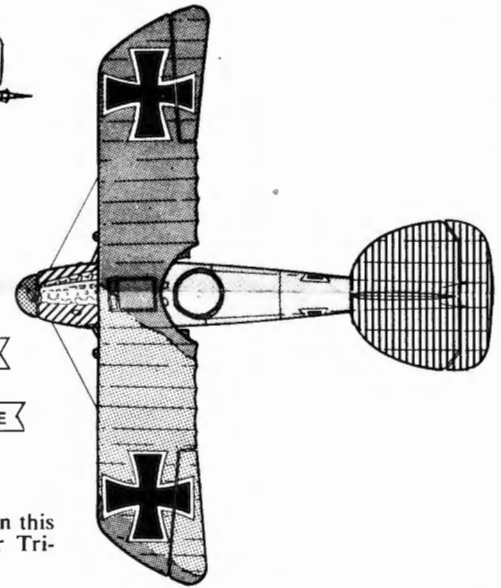
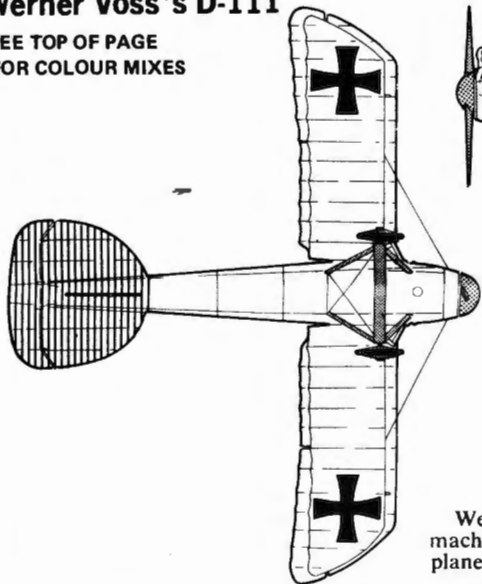

SILVER
F.S. 1717B

MATT WHITE
F.S. 37875

OLIVE GREEN
F.S. 34092

MATT LIGHT BLUE
F.S. 35526

MATT DARK PURPLE
F.S. NONE

MATT LT. TAN

Werner Voss scored many of his victories in this machine before receiving the second Fokker Triplane produced.

Herman Göring's D-III

SEE TOP OF PAGE
FOR COLOUR MIXES

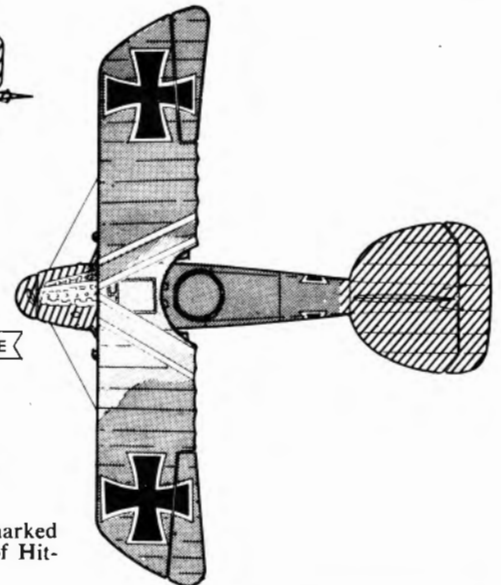
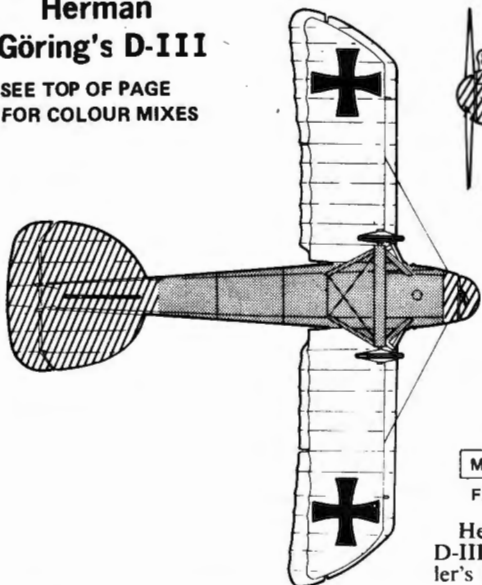

MATT WHITE
F.S. 37875

MATT LIGHT BLUE
F.S. 35526

MATT DARK PURPLE
F.S. NONE

OLIVE GREEN
F.S. 34092

Herman Göring flew this black and white marked D-III with Jasta 27. He was later the head of Hitler's Luftwaffe in World War II.