

PLASTIC PARTS

A>

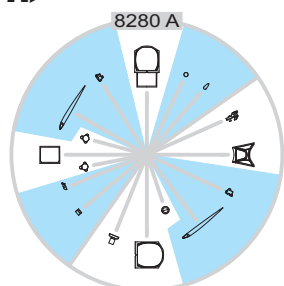

H>

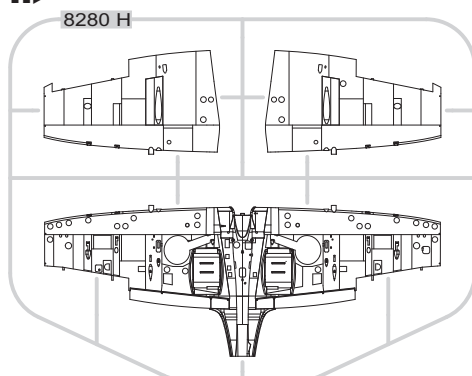

I>

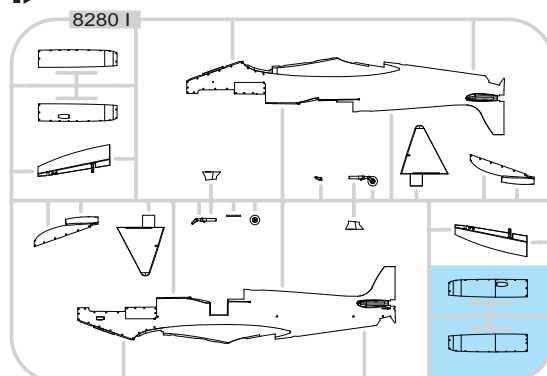

F>

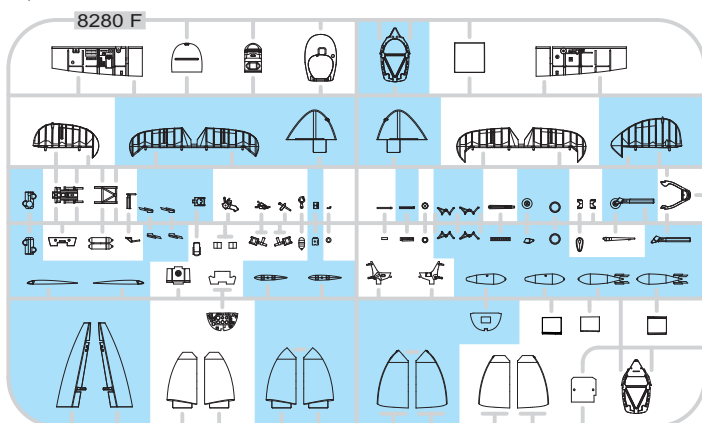

G>

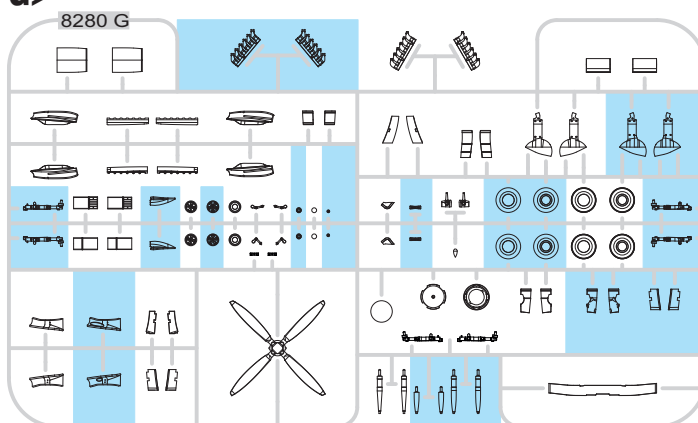

GUNZE	MISSION MODELS	
H4	C4	MMP-007 YELLOW
H12	C33	MMP-047 FLAT BLACK
H13	C3	MMP-003 FLAT RED
H33	C81	MMP-003 RUSSET
H51	C11	MMP-063 LIGHT GULL GRAY
H71	C21	MMP-076 MIDDLE STONE
H72	C362	MMP-078 DARK EARTH

GUNZE	MISSION MODELS	
H77	C137	MMP-047 TIRE BLACK
H90	C47	MMP-047 CLEAR RED
H94	C138	MMP-047 CLEAR GREEN
H335	C363	MMP-094 MEDIUM SEAGRAY
	C364	MMP-079 AIRCRAFT GRAY-GREEN
	C370	MMP-092 AZURE BLUE

MC/METAL	MC/SUBSTR.	MMM-001	METALLICS
MC214	MMM-001		DARK IRON
MC218	MMM-003		ALUMINIUM
MMC/SUBSTR.	MMC-001		METALLICS
SM01	MMC-001		SUPER CHROME

ATTENTION * UPOZORNĚNÍ * ACHTUNG * ATTENTION

GB

Carefully read instruction sheet before assembling. When you use glue or paint, do not use near open flame and use in well ventilated room. Keep out of reach of small children. Children must not be allowed to suck any part, or pull vinyl bag over the head.

CZ

Před započatím stavby si pečlivě prostudujte stavební návod. Při používání barev a lepidel pracujte v dobře větrané místnosti. Lepidla ani barvy nepoužívejte v blízkosti otevřeného ohně. Model není určen malým dětem, mohlo by dojít k požití drobných dílů.

D

Vor dem Zusammenbau die Bauanleitung gut durchlesen. Kleber und Farben nicht in der Nähe von offenem Feuer verwenden und für eine ausreichende Belüftung sorgen. Den Bausatz von kleinen Kindern fernhalten. Vermeiden Sie, dass Kinder Bauteile in den Mund nehmen oder sich Plastiktüten über den Kopf ziehen.

F

Lire soigneusement la fiche d'instructions avant d'assembler. Ne pas utiliser de colle ou de peinture à proximité d'une flamme nue, et aérer la pièce de temps en temps. Garder hors de portée des enfants en bas âge. Ne pas laisser les enfants mettre en bouche ou sucer les pièces, ou passer un sachet vinyl sur la tête.

INSTRUCTION SIGNS * INSTR. SYMBOLY * INSTRUKTION SINNBILDEN * SYMBOLES

OPTIONAL
VOLBABEND
OHNOUTSAND
BROUSITOPEN HOLE
VYVRTAT OTVORSYMETRICAL ASSEMBLY
SYMETRICKÁ MONTÁŽREMOVE
ODŘÍZNOUTREVERSE SIDE
OTOČITAPPLY EDUARD MASK
AND PAINT
POUŽIT EDUARD MASK
NABARVIT

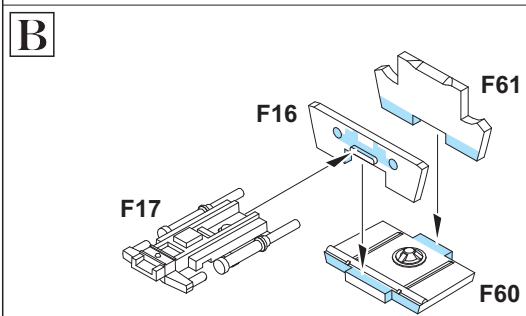
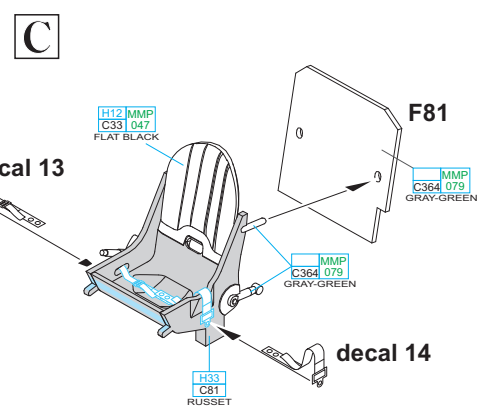
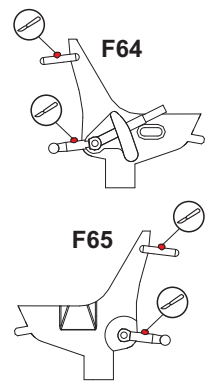
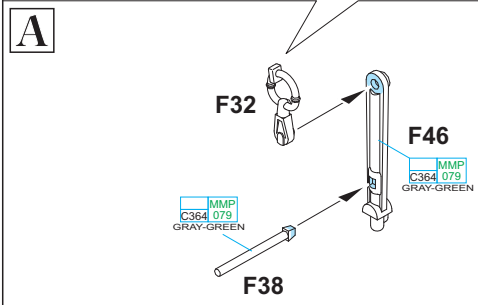
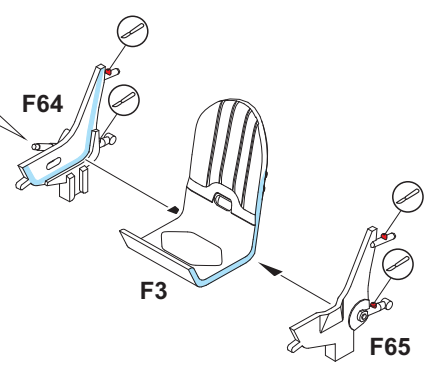
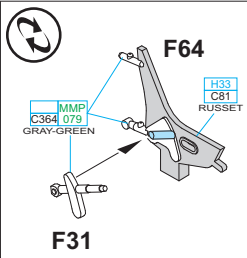
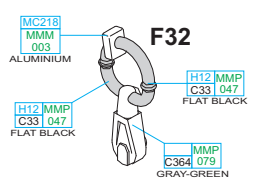
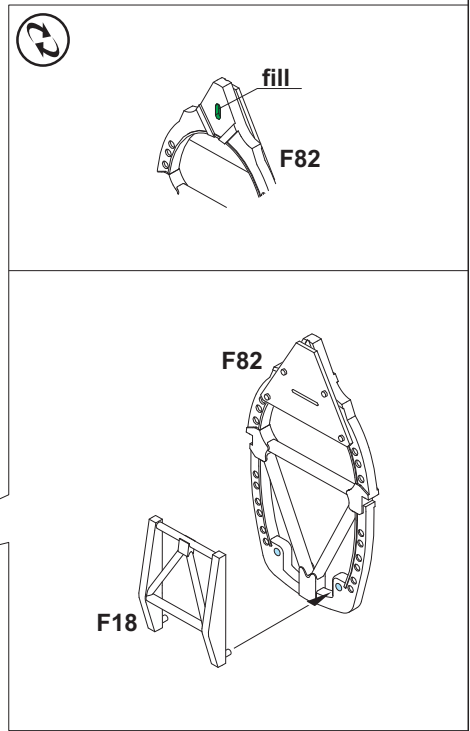
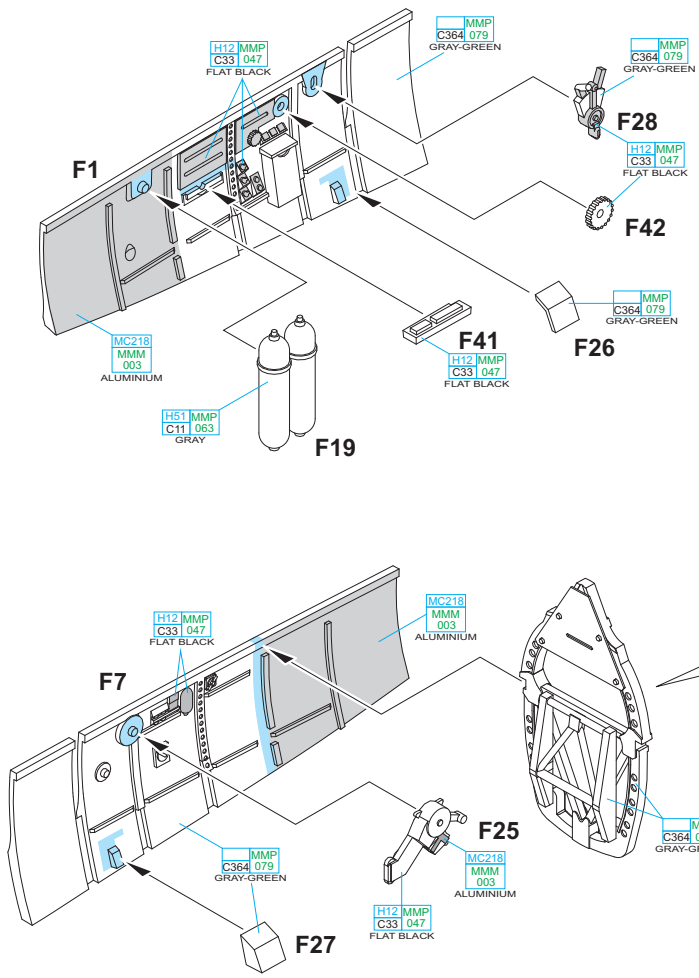

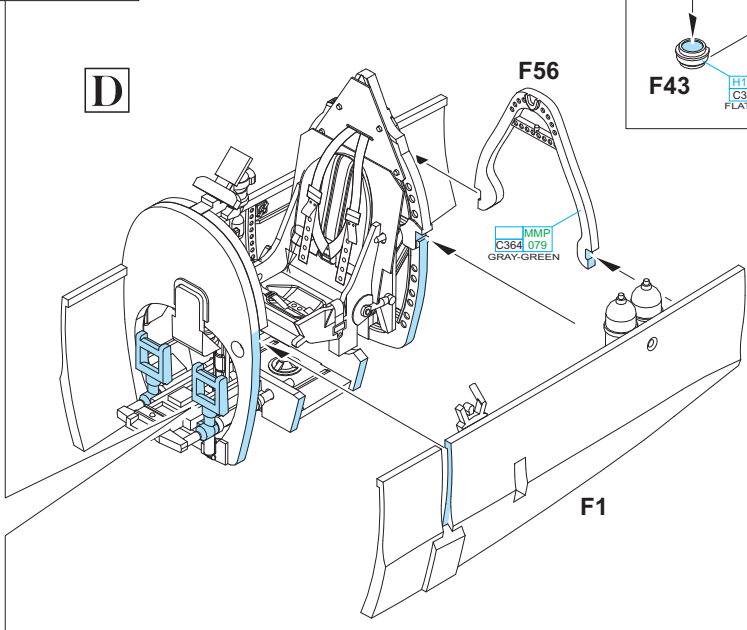
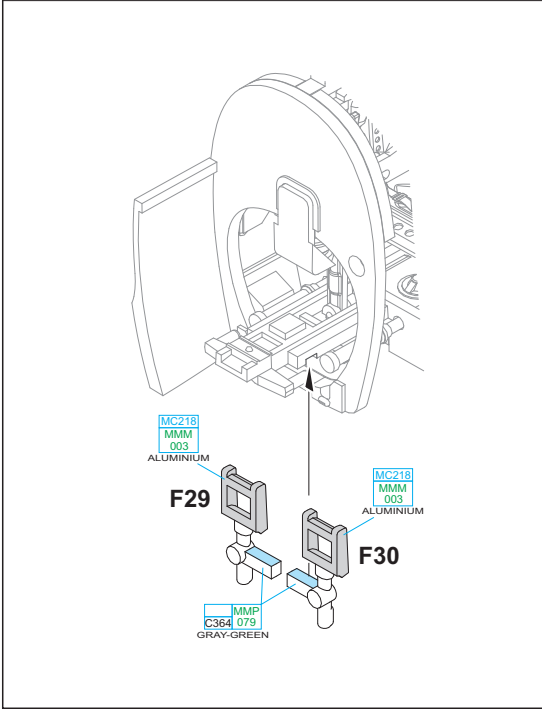
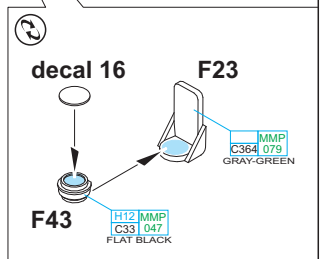
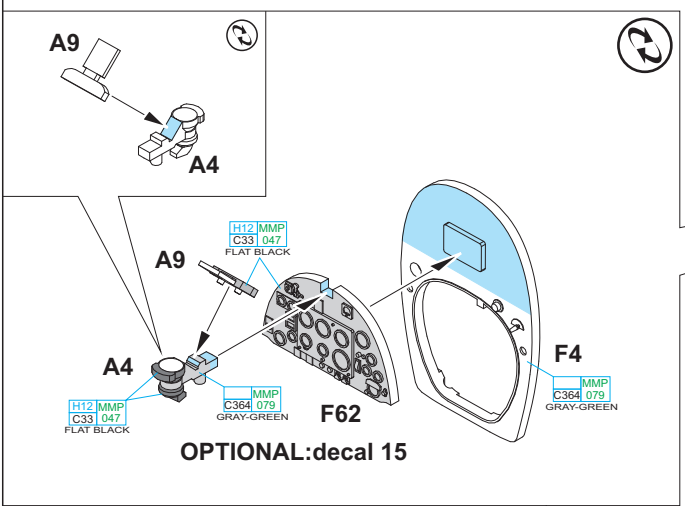
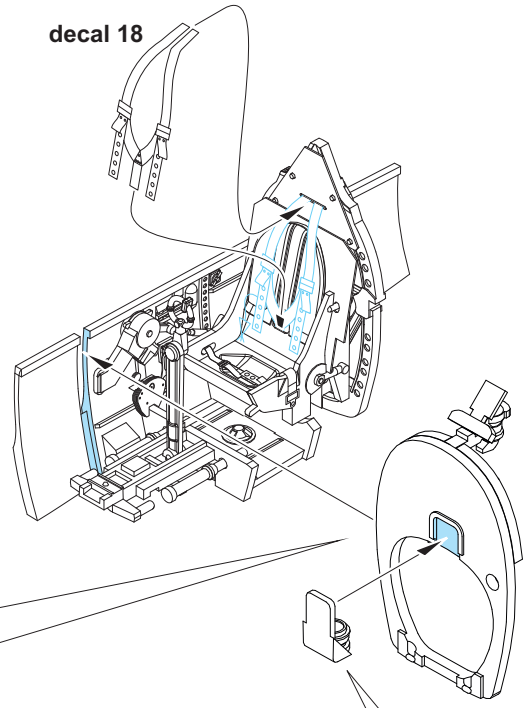
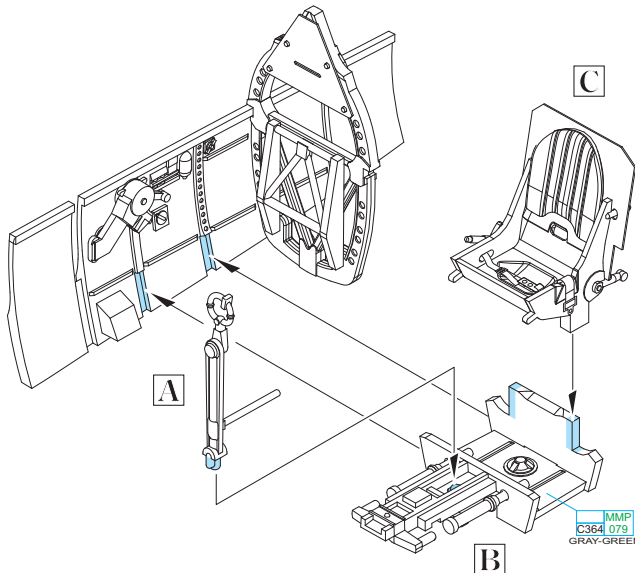

⑦ FOR CLOSED CANOPY ONLY

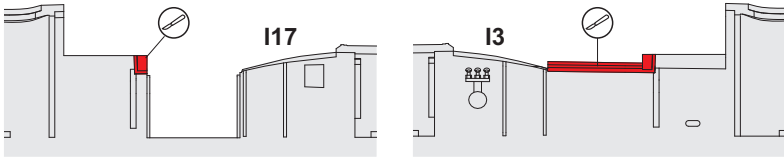

MMP
C364 079
GRAY-GREEN

I13

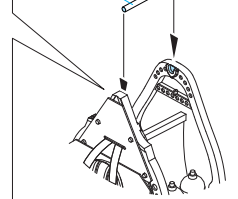
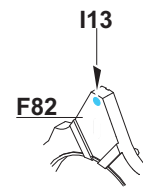

E

F2

F6

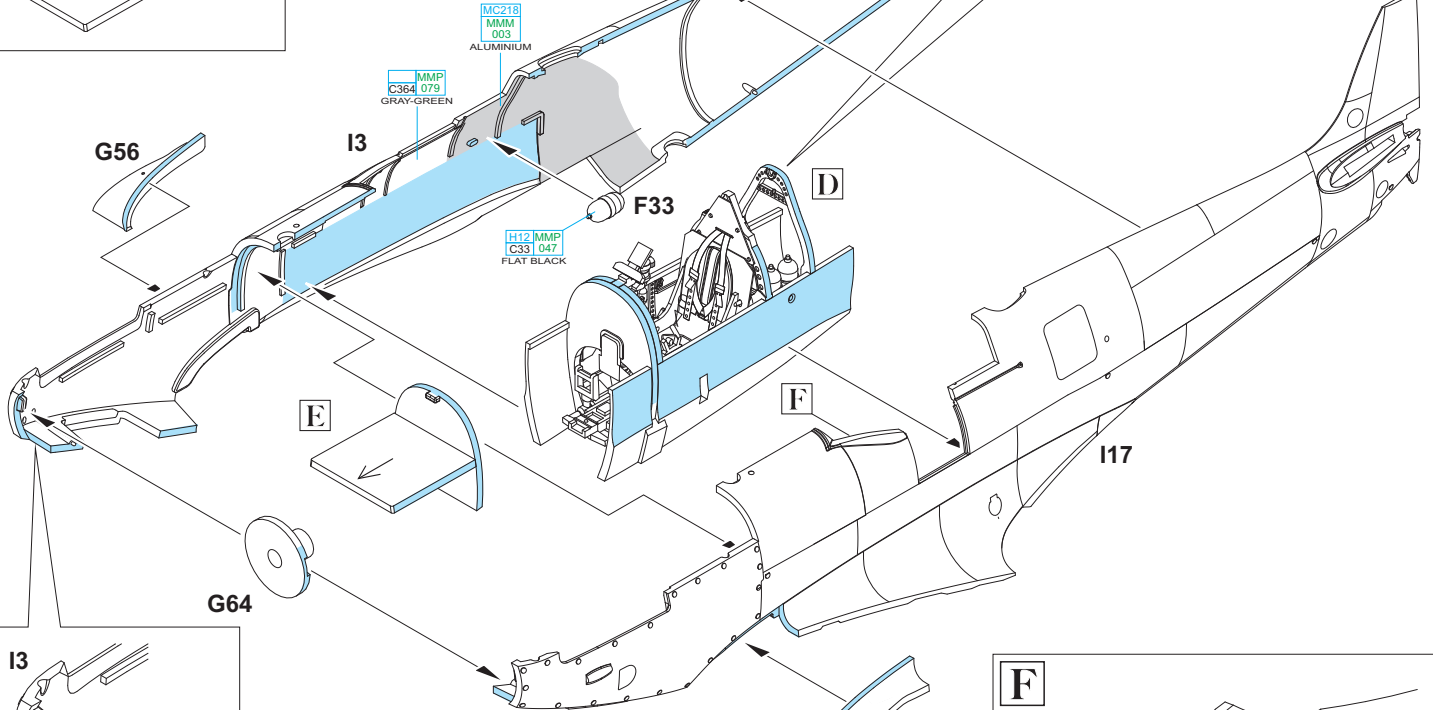
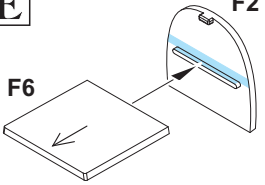

MC218
MMM
003
ALUMINIUM

MMP
C364 079
GRAY-GREEN

H12 MMP
C33 047
FLAT BLACK

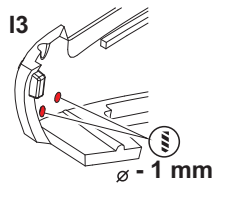

∅ - 1 mm

F

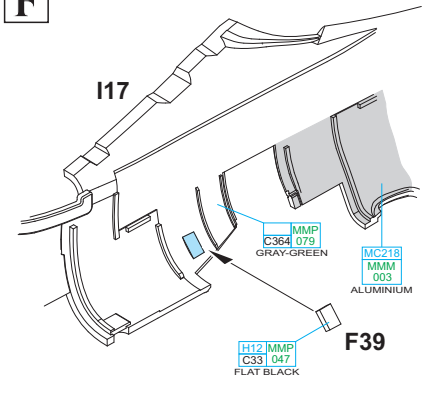

MMP
C364 079
GRAY-GREEN

MC218
MMM
003
ALUMINIUM

H12 MMP
C33 047
FLAT BLACK

F39

A16

H94
C138
CLEAR GREEN

MMP
C370 092
AZURE BLUE

G76

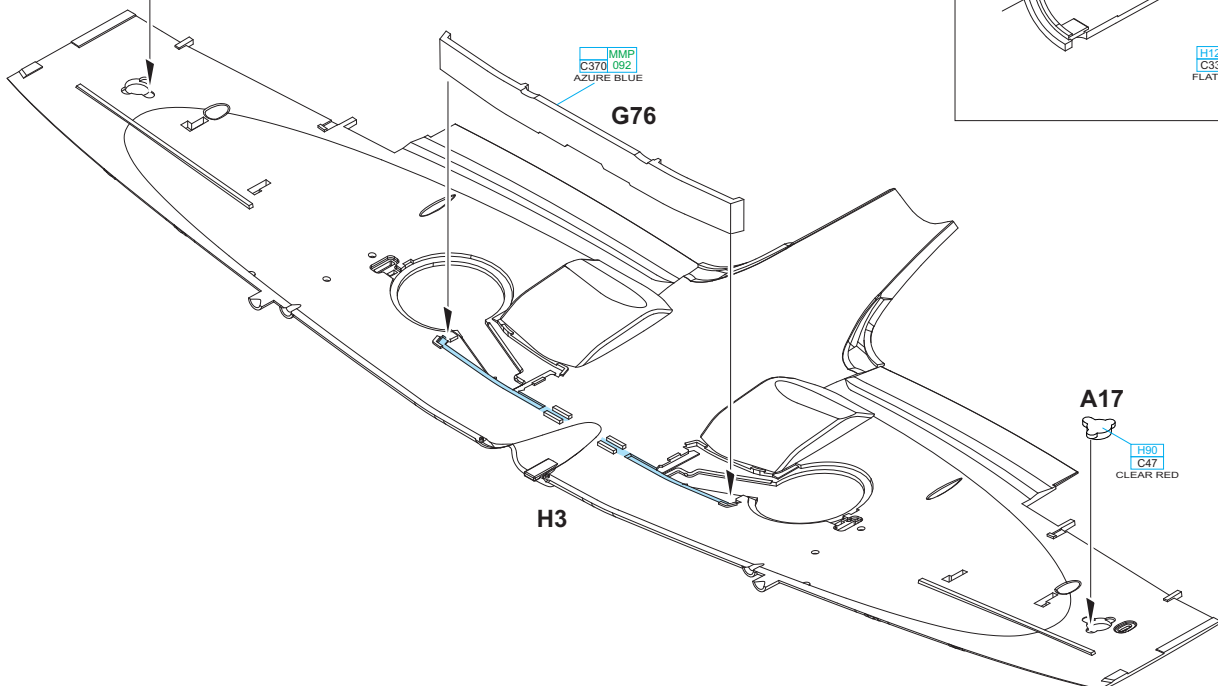

A17

H90
C47
CLEAR RED

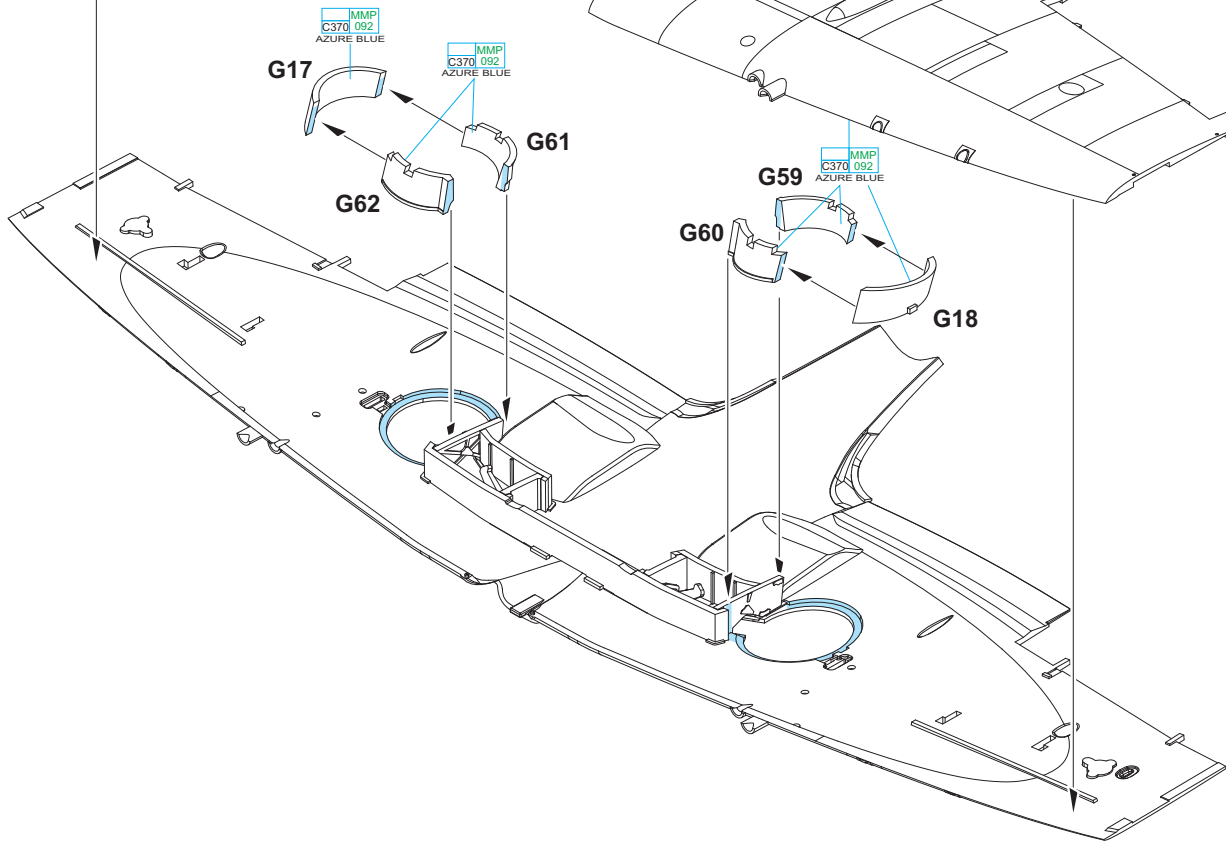
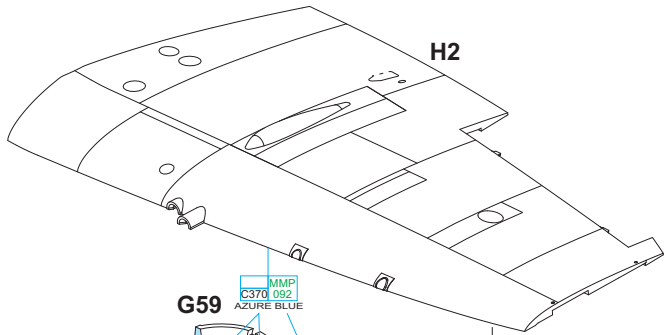
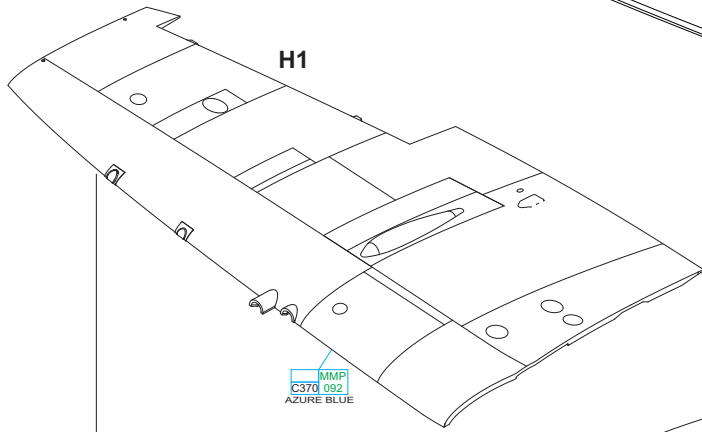
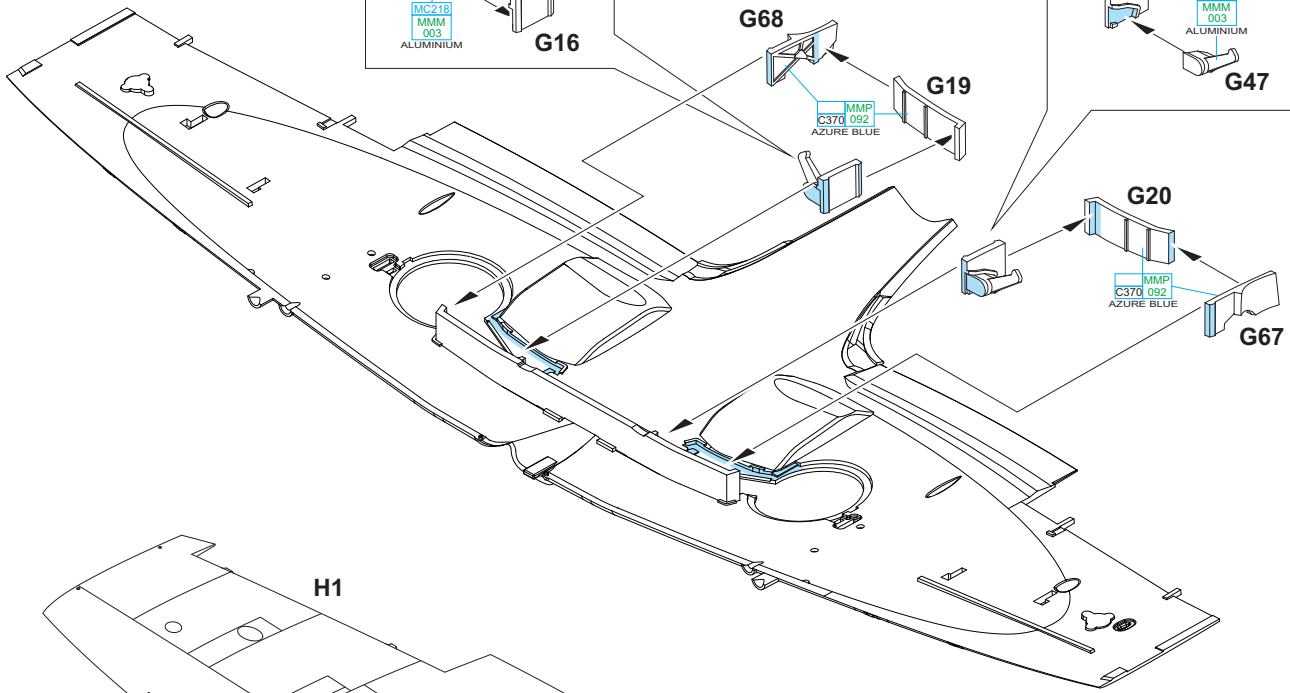
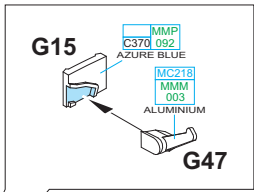
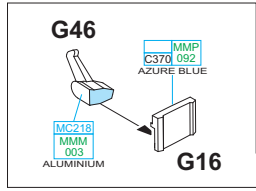

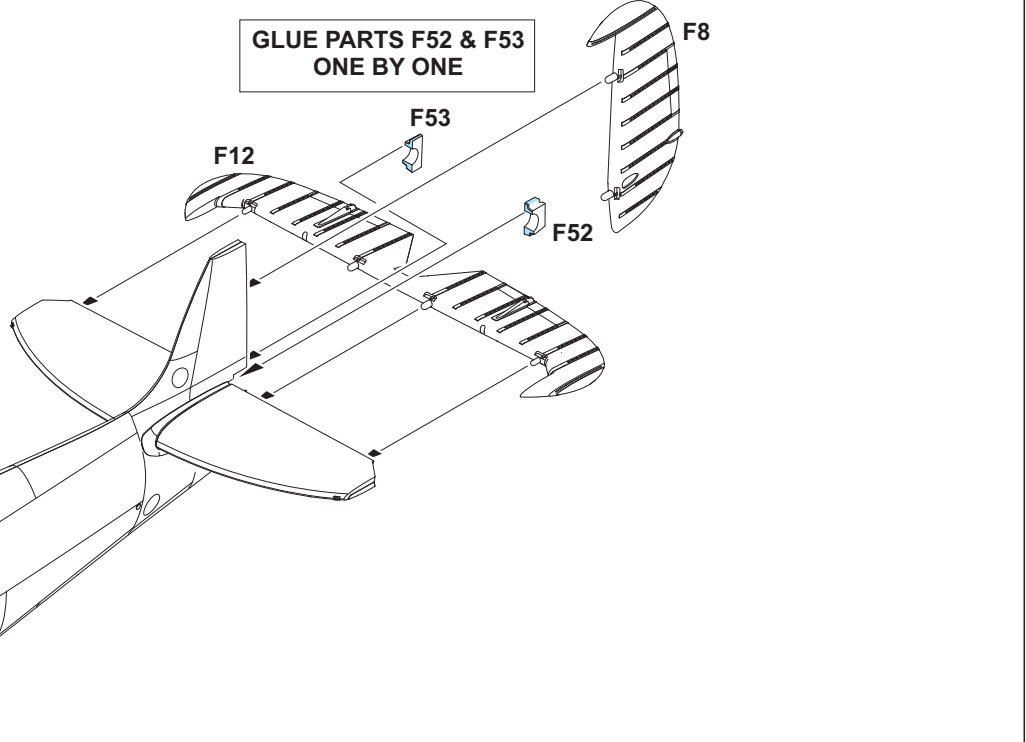
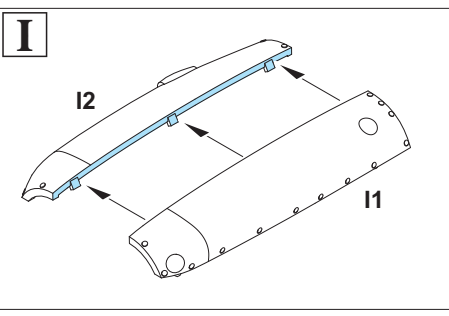
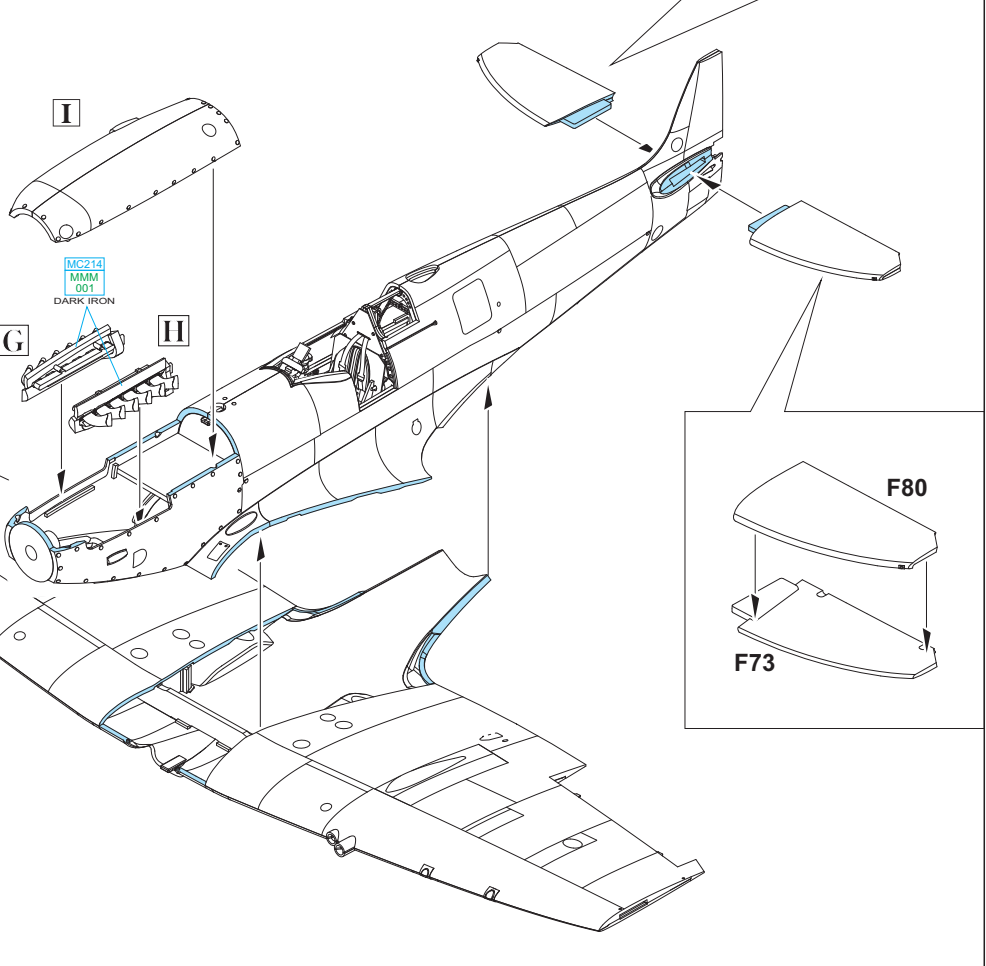
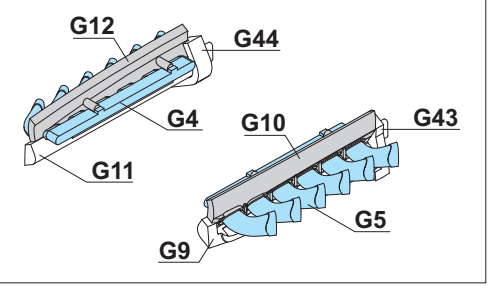
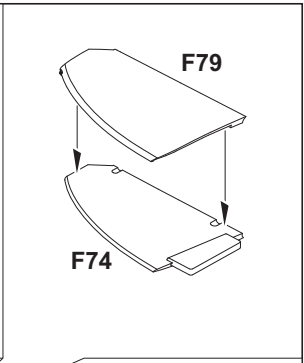
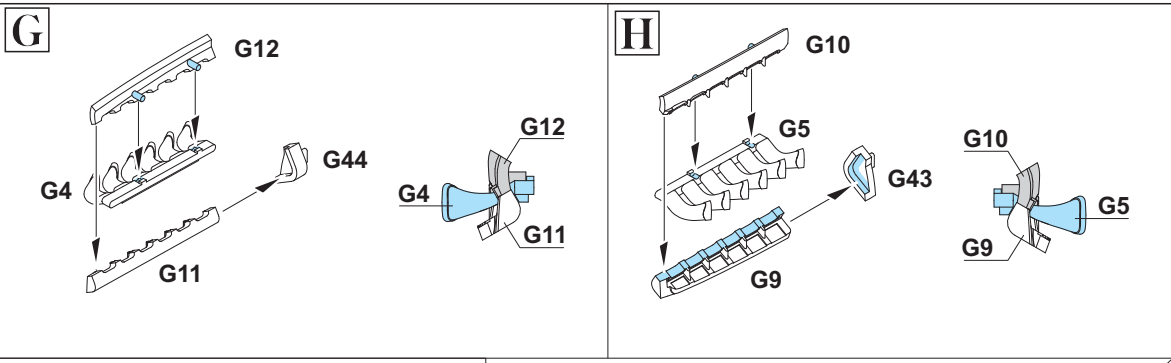

I8
H94
C138
CLEAR GREEN

I4

I16

J

I9

I10

H90
C47
CLEAR RED

I11

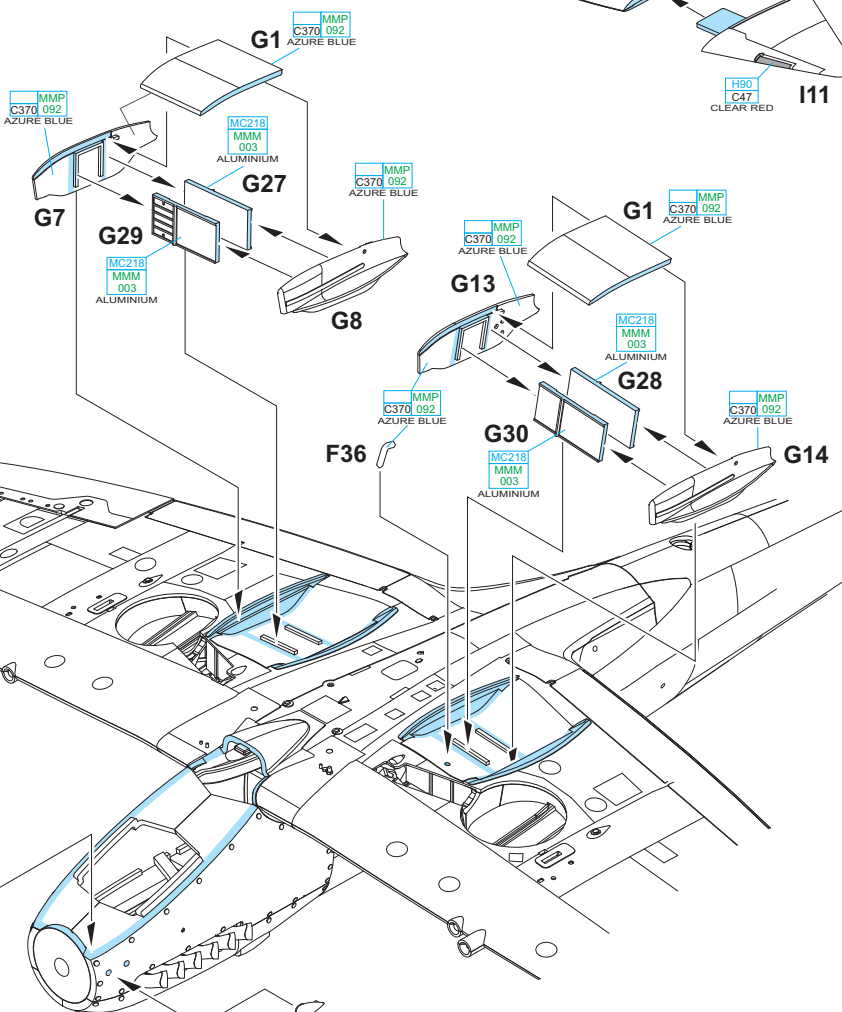

J

G48

MMP
C370 092
AZURE BLUE

G6

G6

MMP
C370 092
AZURE BLUE

G6

G6

G37 right ↔ **G39 left**

G37 ↔ **G39**

G38 right ↔ **G36 left**

G38 ↔ **G36**

MMP
C370 092
AZURE BLUE

MMP
C370 092
AZURE BLUE

?

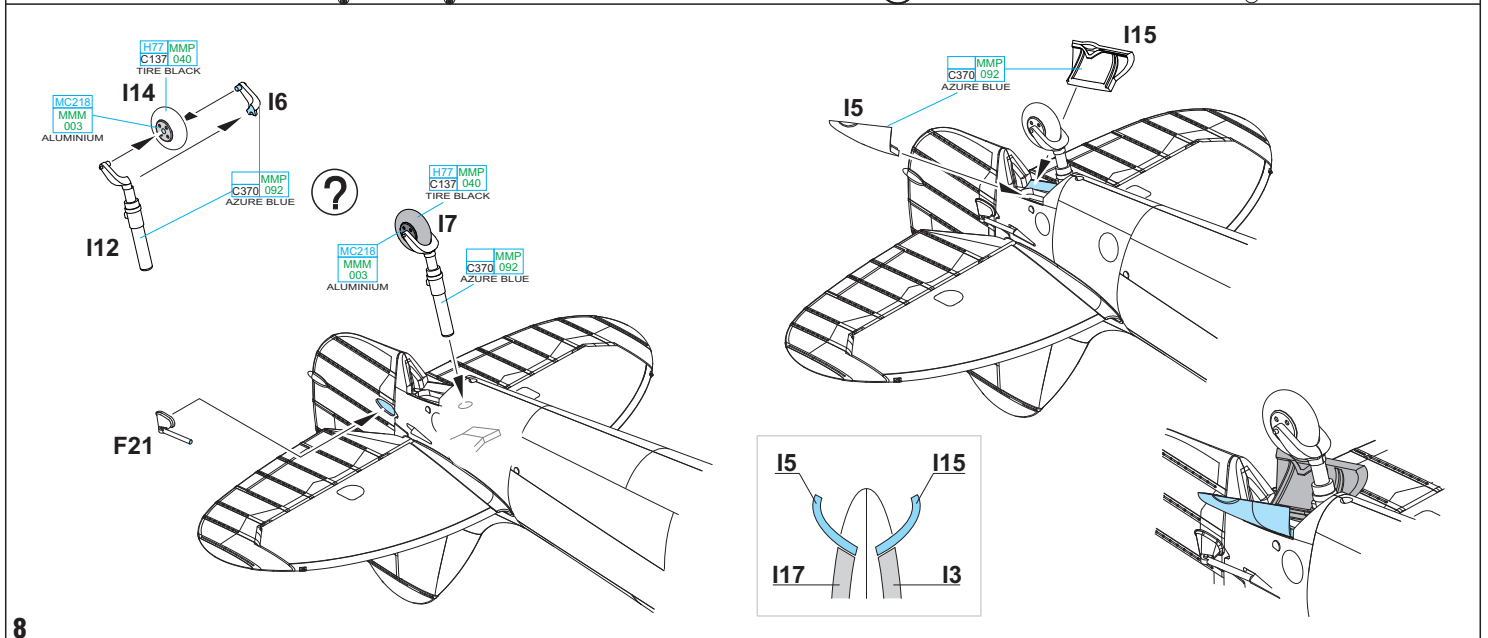
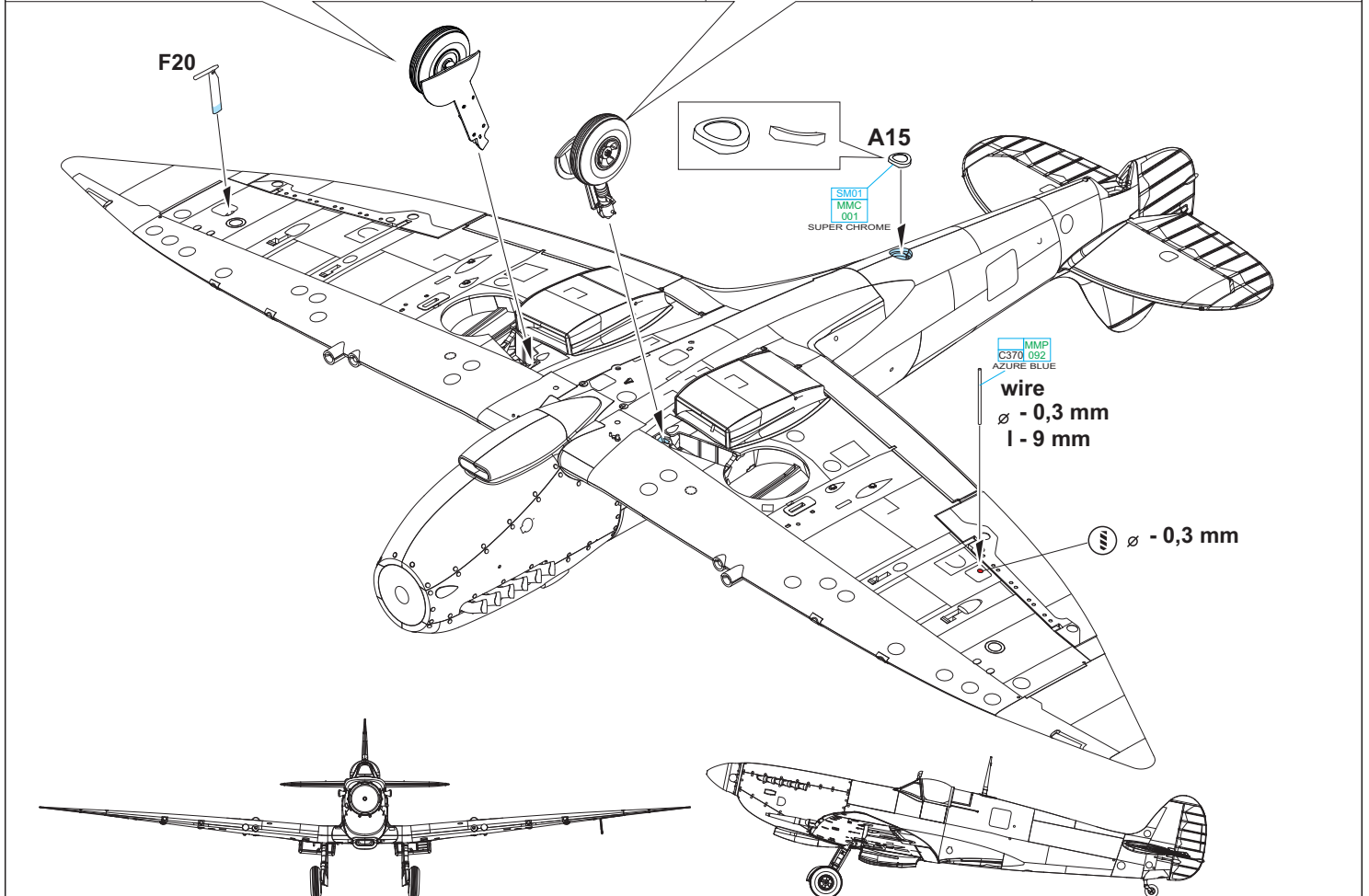
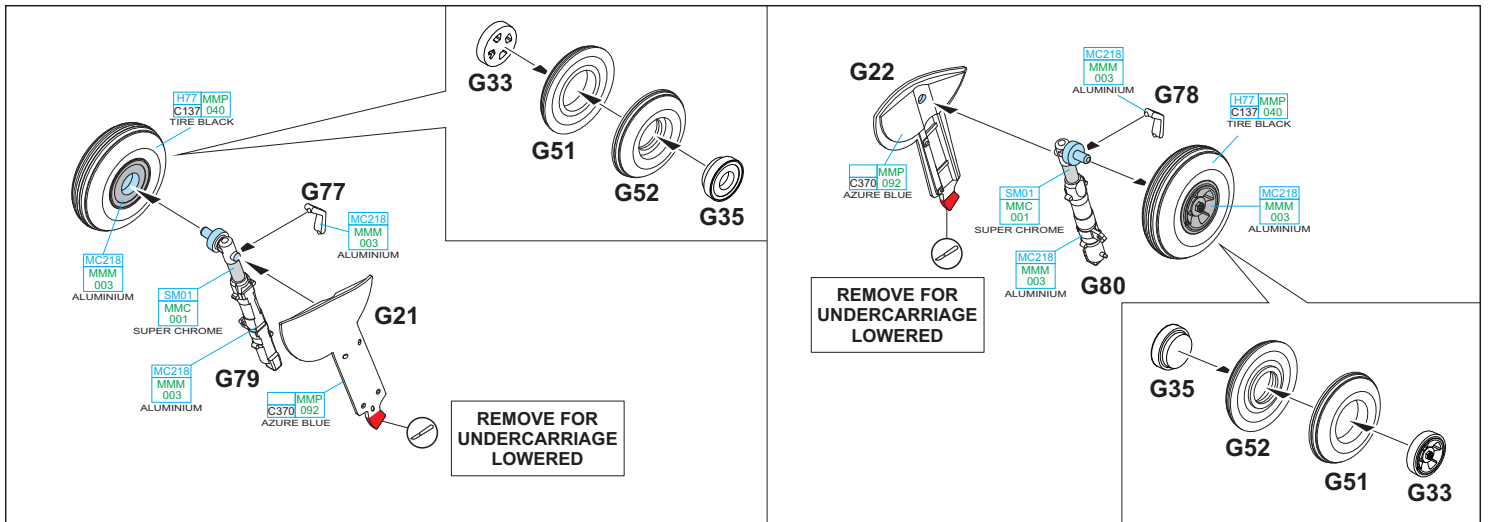

K

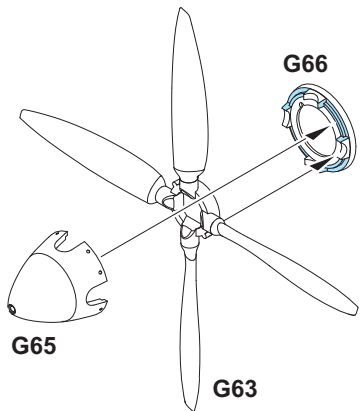

OPEN CANOPY

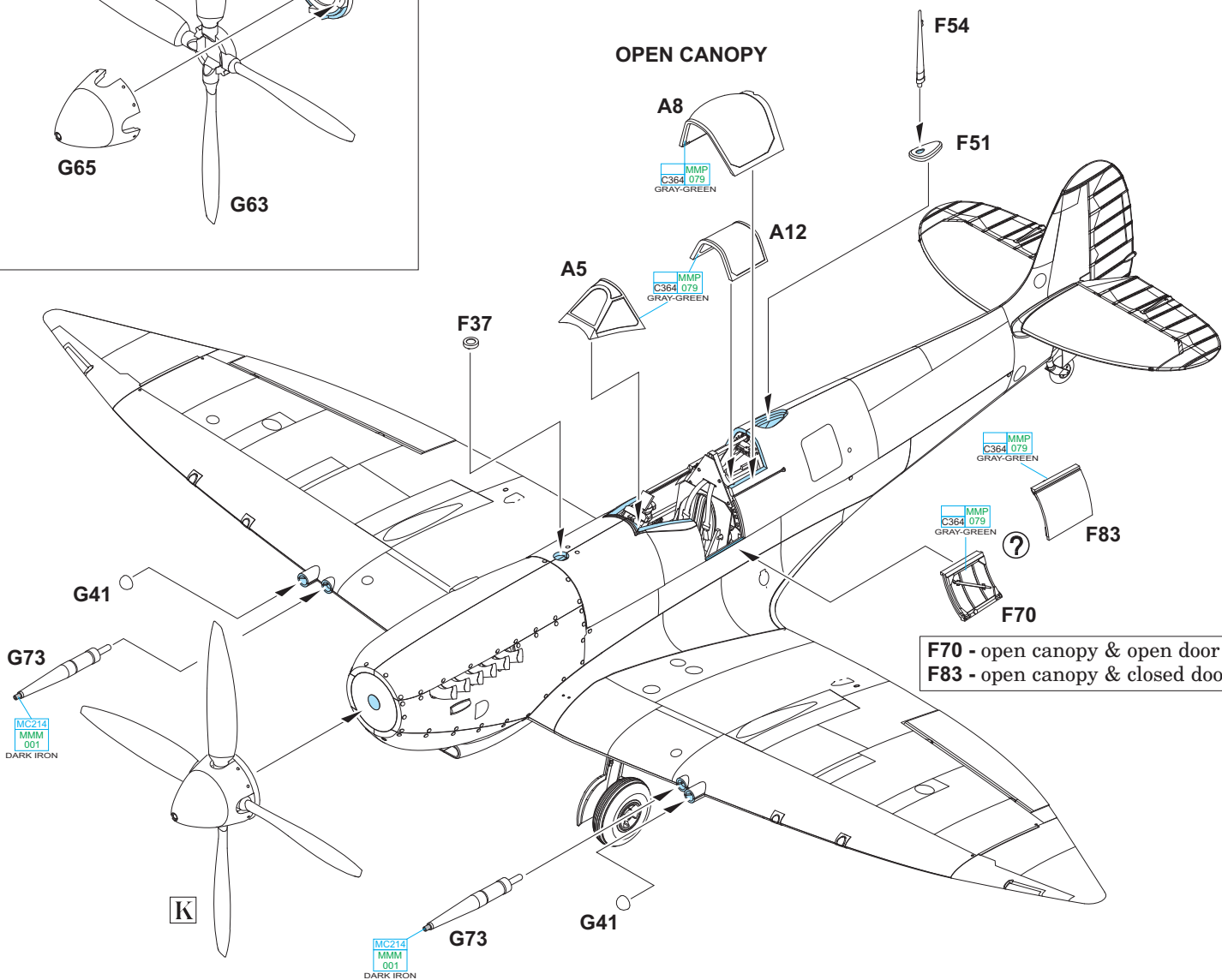

F70 - open canopy & open door
F83 - open canopy & closed door

?

CLOSED CANOPY

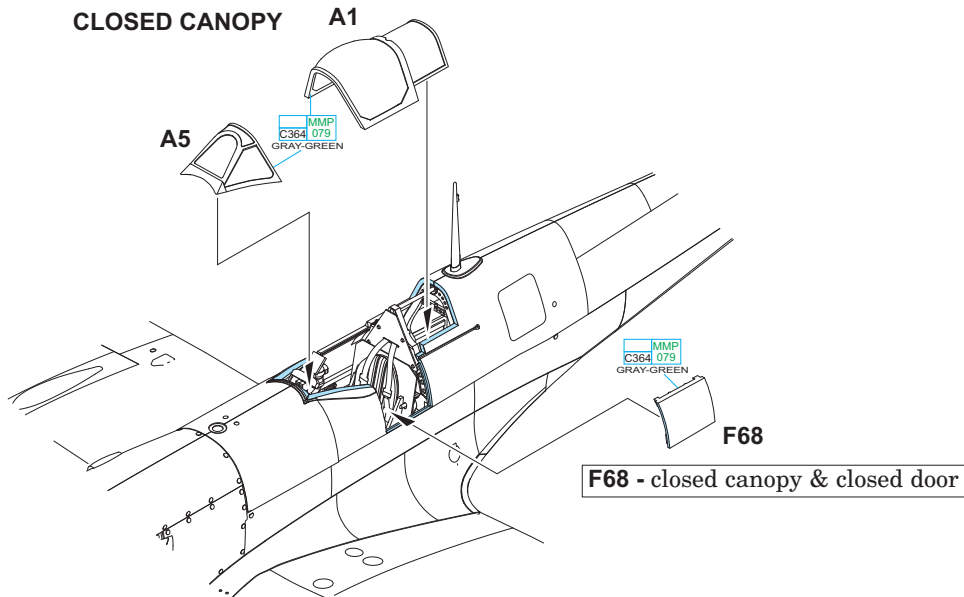

F68 - closed canopy & closed door

A JF587, flown by Lt. J.E. Gasson, No. 92 Squadron, Marcianise Airfield, Italy, early 1944

Originally No. 92 Fighter Squadron fighting in WWI was disbanded in August 1919. On October 10th, 1939 a squadron bearing the same number was established. It was first equipped with Bristol Blenheims. Right at the beginning of year 1940 it got Spitfires, which were fighting above Dunkerque and also fought in the Battle of Britain. In February 1942 the squadron was sent to Africa where it served against German and Italian armed forces. After the fights in Africa terminated, the squadron fought above Malta and Sicily, later the squadron served above Italy. The squadron was disbanded on December 30th, 1946 in Austrian Zeltweg. During WWII it reached the highest number of shot downs of the enemy aircraft among the RAF Wings, 317 victories over the enemy aircraft. No. 92 Squadron aircraft had a Desert camouflage scheme. This consisted of Dark Earth and Middle Stone colours on the top surfaces, the undersides were painted in Azure Blue colour. The colour of the letters of coding of the squadron could not be clearly determined, various sources state blue or red. Both sides of the fuselage bore Desert Air Force badge.

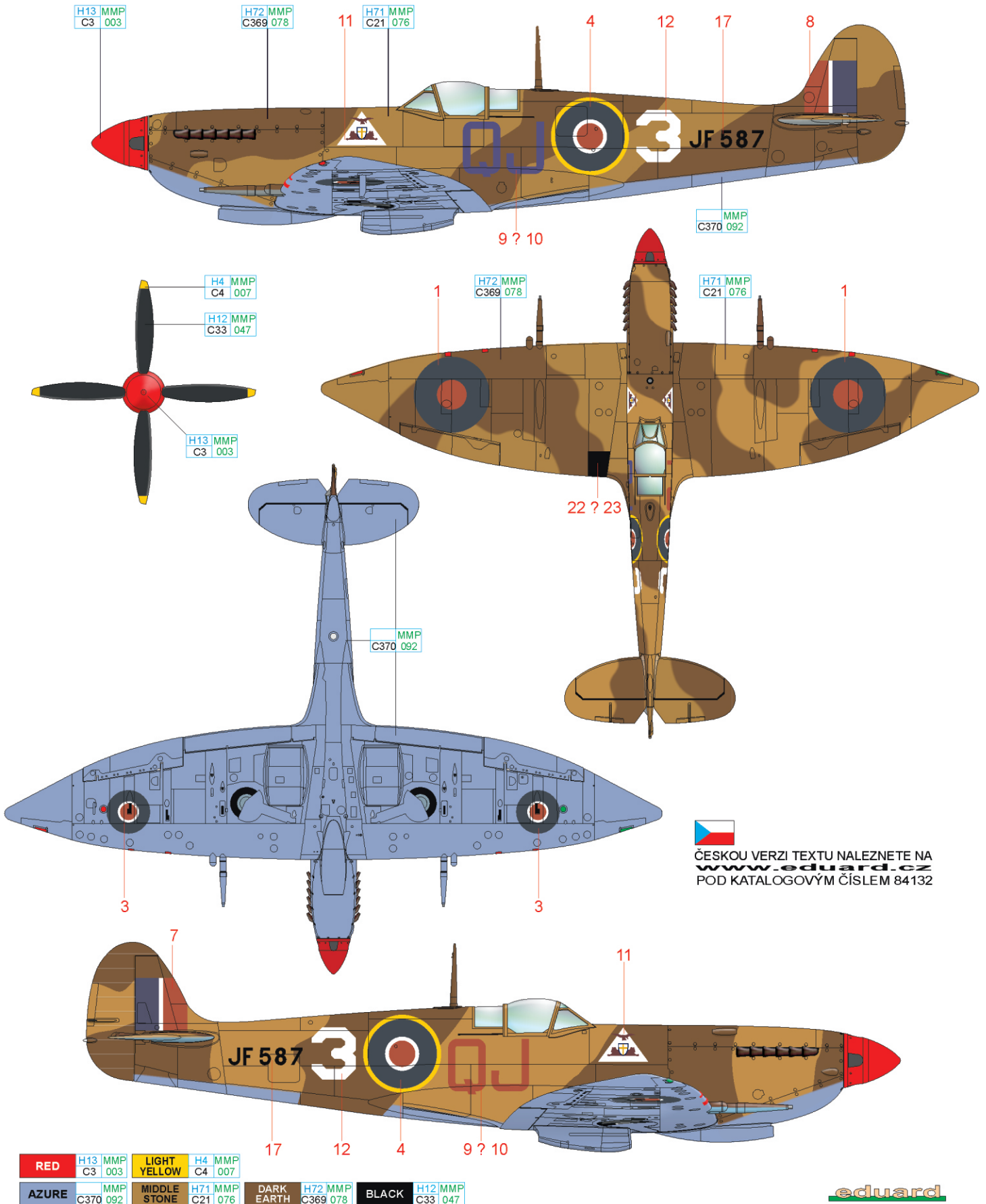

ČESKOU VERZI TEXTU NALEZNETE NA www.eduard.cz POD KATALOGOVÝM ČÍSLEM 84132

B JF364, No. 32 Squadron, Foggia, Italy, early 1944

The high altitude fighter camouflage scheme adorned this Spitfire as well. In accordance with regulations, red-blue cockades were painted on the fuselage and upper sides of the wings. No national insignia was applied on the bottom of the wings. A photo of this aircraft shows that the GZ code letters did not adhere to regulations on the right side of the fuselage.

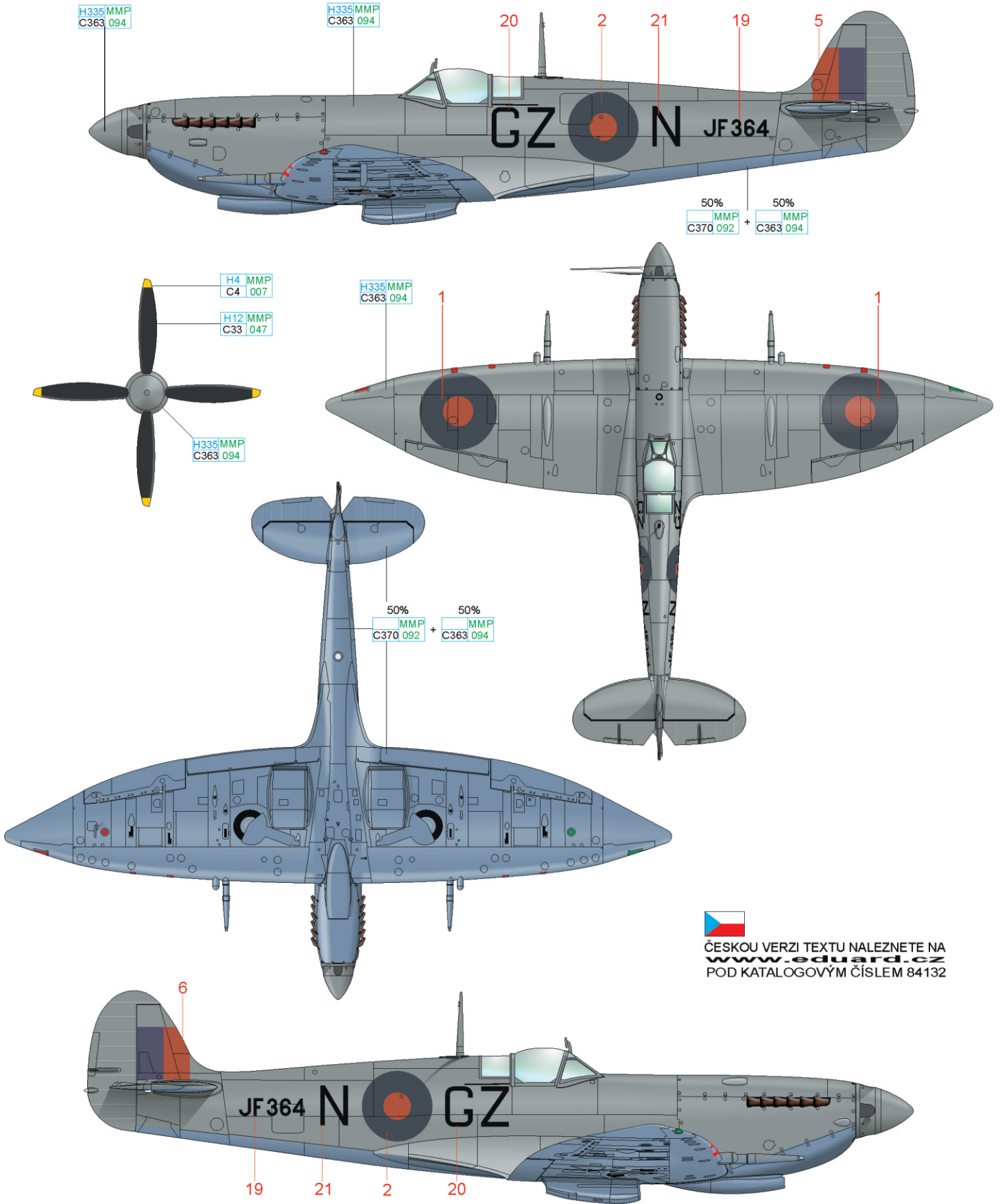

ČESKOU VERZI TEXTU NALEZNETE NA
www.eduard.cz
 POD KATALOGOVÝM ČÍSLEM 84132

LIGHT YELLOW	H4 MMP C4 007	BLACK	H12 MMP C33 047	MEDIUM SEA GRAY	H335 MMP C363 094	PRU BLUE	50% MMP C370 092	+	50% MMP C363 094
--------------	---------------	-------	-----------------	-----------------	-------------------	----------	------------------	---	------------------

Spitfire HF Mk.VIII

STENCILING POSITIONS

