



F-16D 52+ ADVANCED VIPER

The latest F-16 rolling off the Lockheed Martin's production line in Fort Worth is advanced Block 50/52. These series represent the largest configuration change in the F-16 history, offering additional fuel and payload capacity, new or improved avionics and sensors, color cockpit displays with enhanced pilot/vehicle interfaces. Nine countries have already ordered Advanced Block 50/52/60 F-16s, including the USA, Greece, Israel, UAE, Chile and Poland.

The Poland Peace Sky program began in April 2003 includes 36 F-16Cs and 12 F-16Ds, all powered by the Pratt & Whitney F100-PW-229 engine. Poland becomes the first former WarPac member to operate the F-16. Poland's F-16s are considered the most advanced in NATO. Features of the Block 52+ include an AN/APG-68(V) 9 radar fire control system (AIDEWS), JHMCS which can fire AIM-9X, AIM-120C, AGM-154 and various precision guide ammunitions. Coupling with the Sniper XR (AAQ-32) Extended Range pod, which is an advanced targeting pod designed with an infrared pointer, laser, day TV, forward looking infrared, laser spot tracker and advanced algorithms. The pod delivers superior tracking performance and reliability.

Block 52 F-16s are difficult to be distinguished from previous F-16s, as most changes are internal. However, the Advanced Block 52s are equipped with a dorsal avionics compartment that accommodates all of the systems, some special mission equipment and additional chaff/flare dispensers.

Block 52 F-16s have structural, plumbing, and wiring provisions for the Conformal Fuel Tank (CFT) for extended range and mission endurance. These external, pod-like fuel reservoirs are attached on the upper surface of the F-16's fuselage, with the tank's lower surface conforming to the aircraft shape. The arrangement allows the CFTs to be relatively light weight. With an empty weight of 900 pounds, tank set holds 450 gallons of additional JP-5/8 fuel.

The extra fuel increases range, loiter time, and combat persistence as well as reduces the demand for tanker support. Range increase is on the order of 20 to 40 percent. The tanks have negligible effect on the aircraft agility, at subsonic speed. When fitted with CFT the aircraft retains almost the full handling qualities, flight limits, and signature.

H1	1	White
H2	2	Black
H4	4	Yellow
H5	5	Blue
H8	8	Silver
H9	9	Gold
H52	12	Olive Drab

H18	28	Steel
H12	33	Flat Black
H90	47	Clear Red
H91	48	Clear Yellow
H50	50	Clear Blue
H76	61	Brunt Iron
H28	78	Metal Black

H305	305	Gray FS36118
H306	306	Gray FS36270
H307	307	Gray FS36320
H308	308	Gray FS36375

H1 GSI Creos Aqueous Hobby color

1 GSI Mr.Color

Glue is not included in this kit.

1/48 SCALE AIRCRAFT SERIES NO.10 - F -16DG/DJ

⚠ CAUTION

- *Read carefully and fully understand the instructions before commencing assembly.
- *Keep out of reach of children. Children must not be allowed to put any parts in their mouths, or pull plastic bag over their heads.
- *When using adhesives and paints, please make sure not to use them in closed room or near the fire.
- *When assembling this kit, tools including knives are used. Extra care should be taken to avoid injury.

WARNING: CONTAIN SMALL PARTS NOT FOR CHILDREN UNDER 14 YEARS OF AGE.

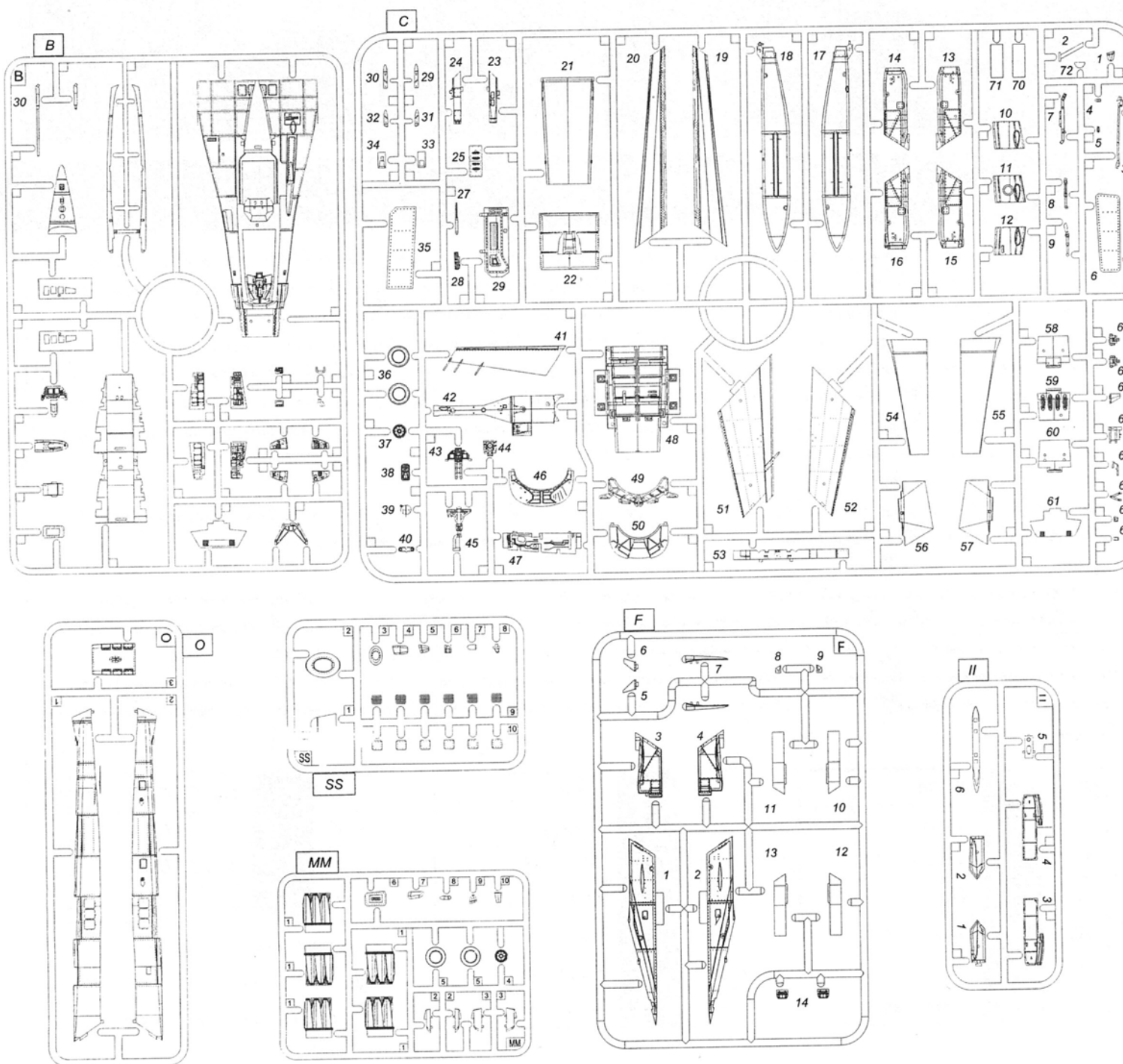

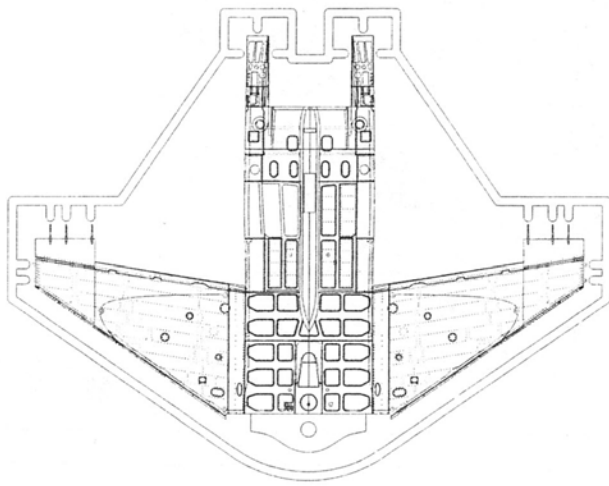
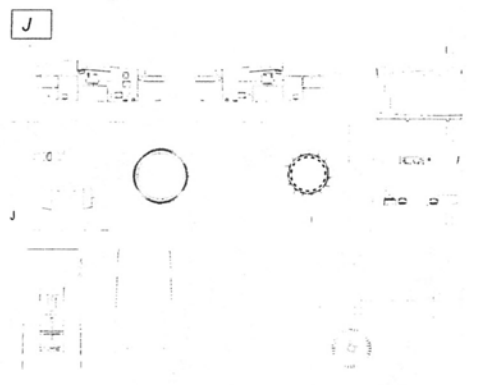
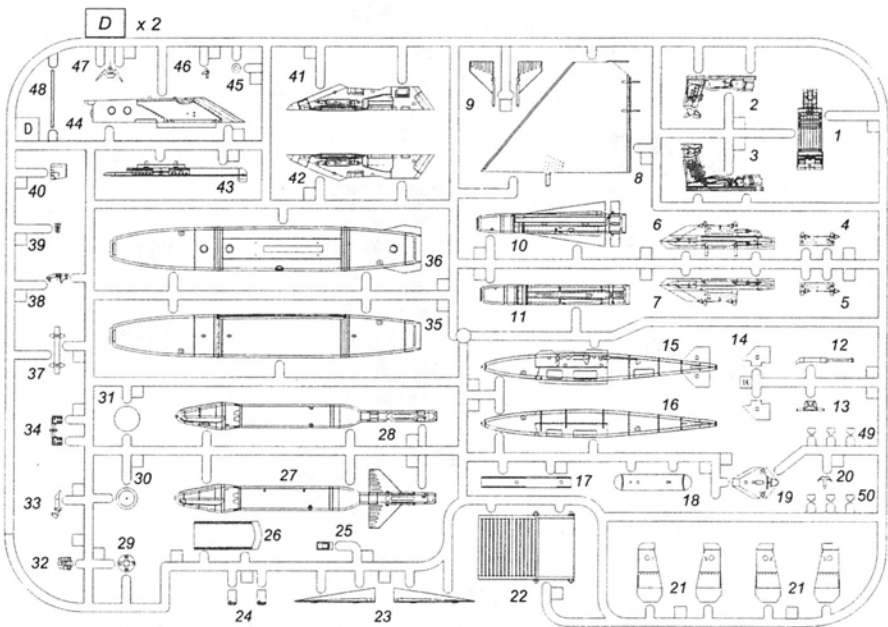

Upper fuselage

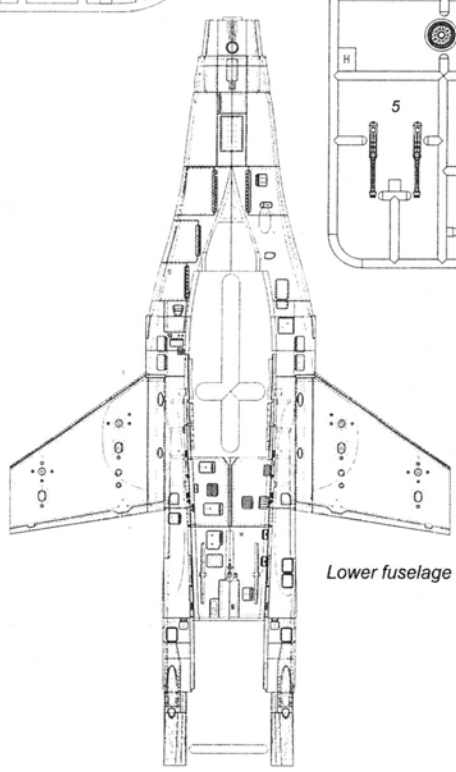

Lower fuselage

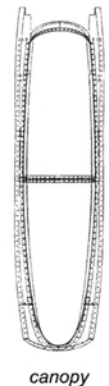
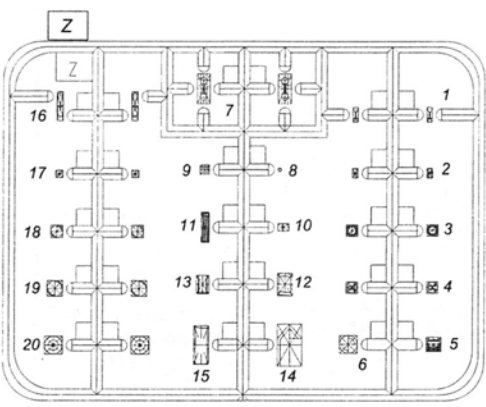
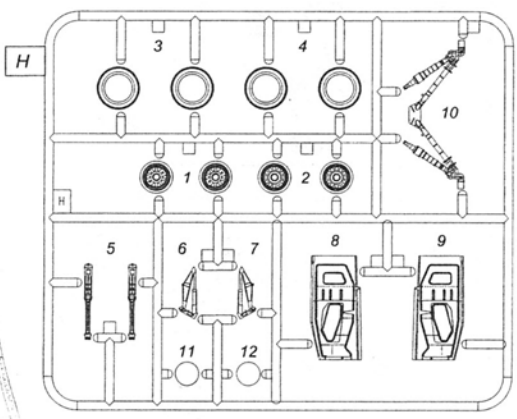

canopy



nose cone

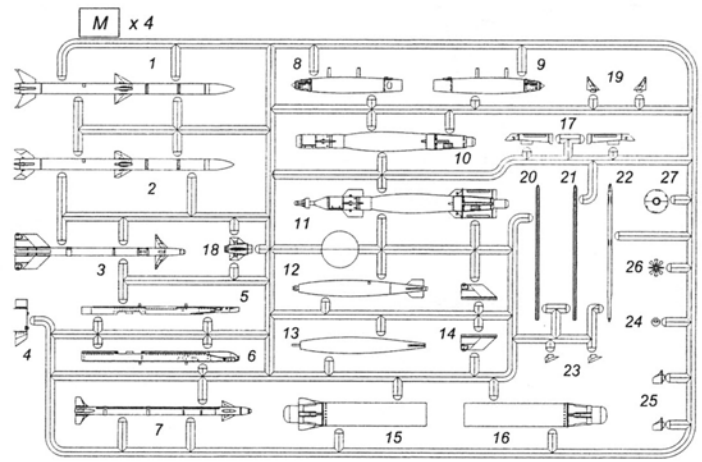

Some parts are not for use. For those parts not shown in the construction manual, please simply neglect them as they will not be used for building this model.

4

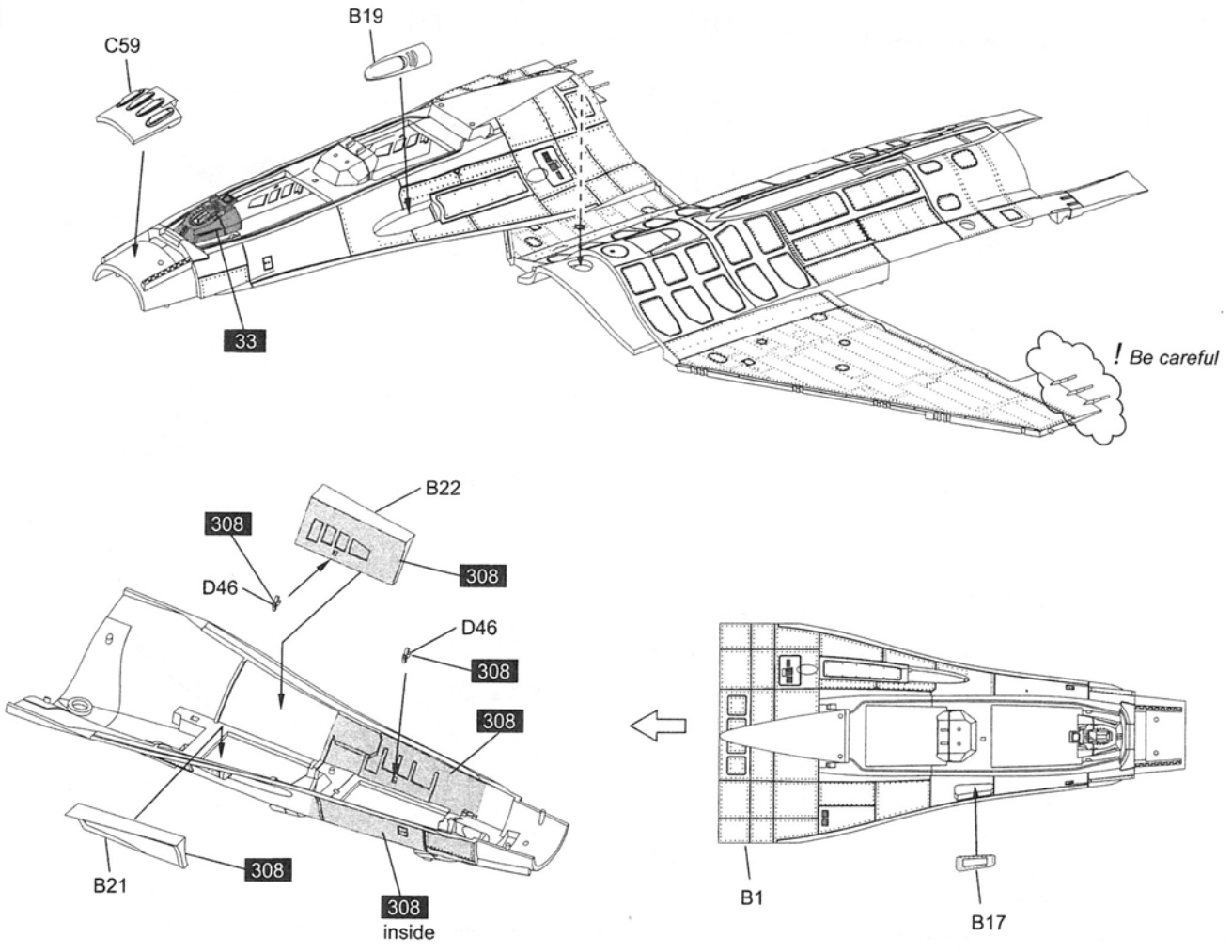

5

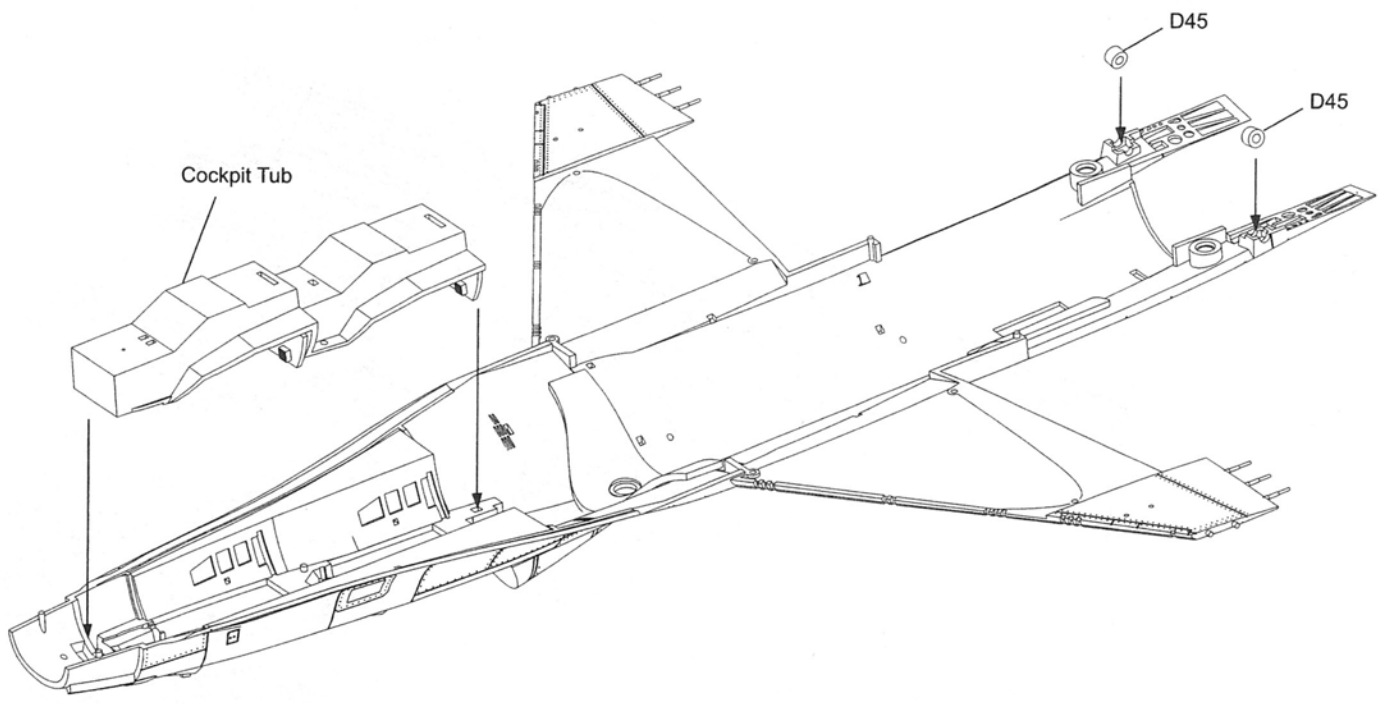

6

Cut along the lines for open air brake

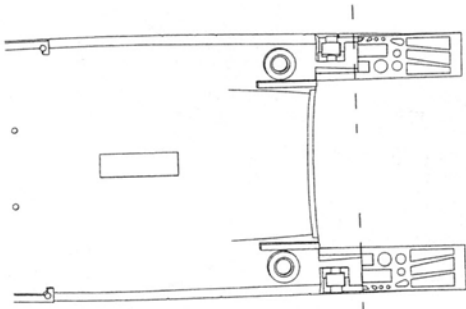

Upper Fuselage

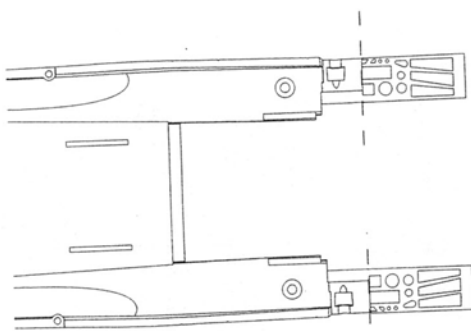

Lower Fuselage

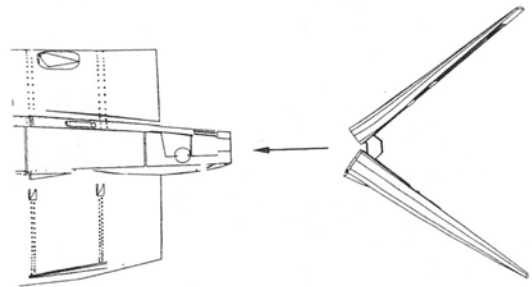
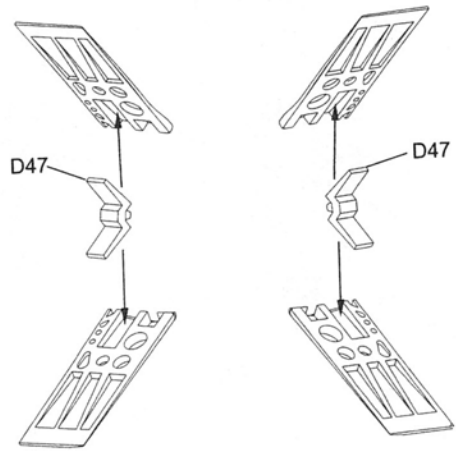

7

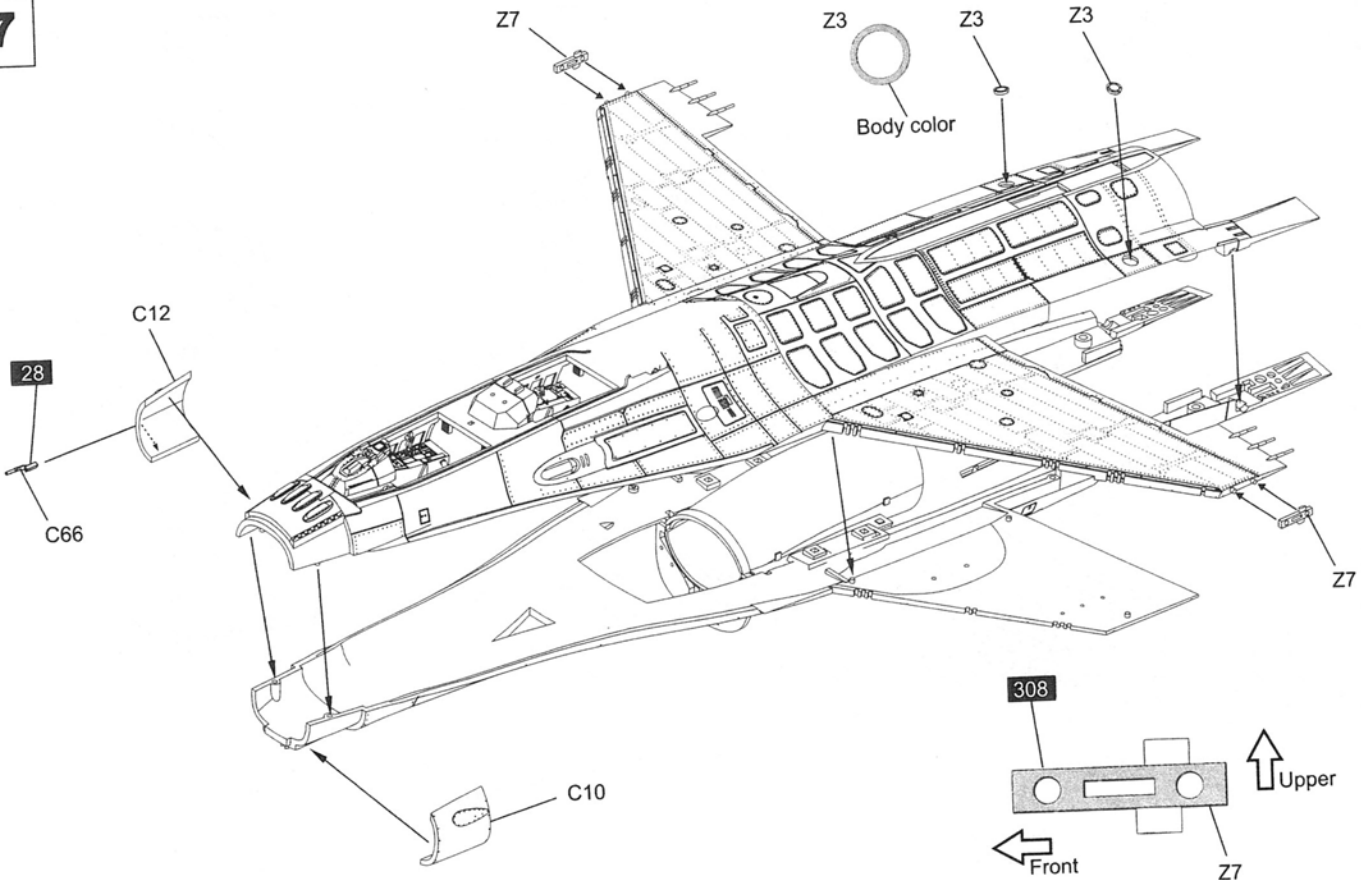

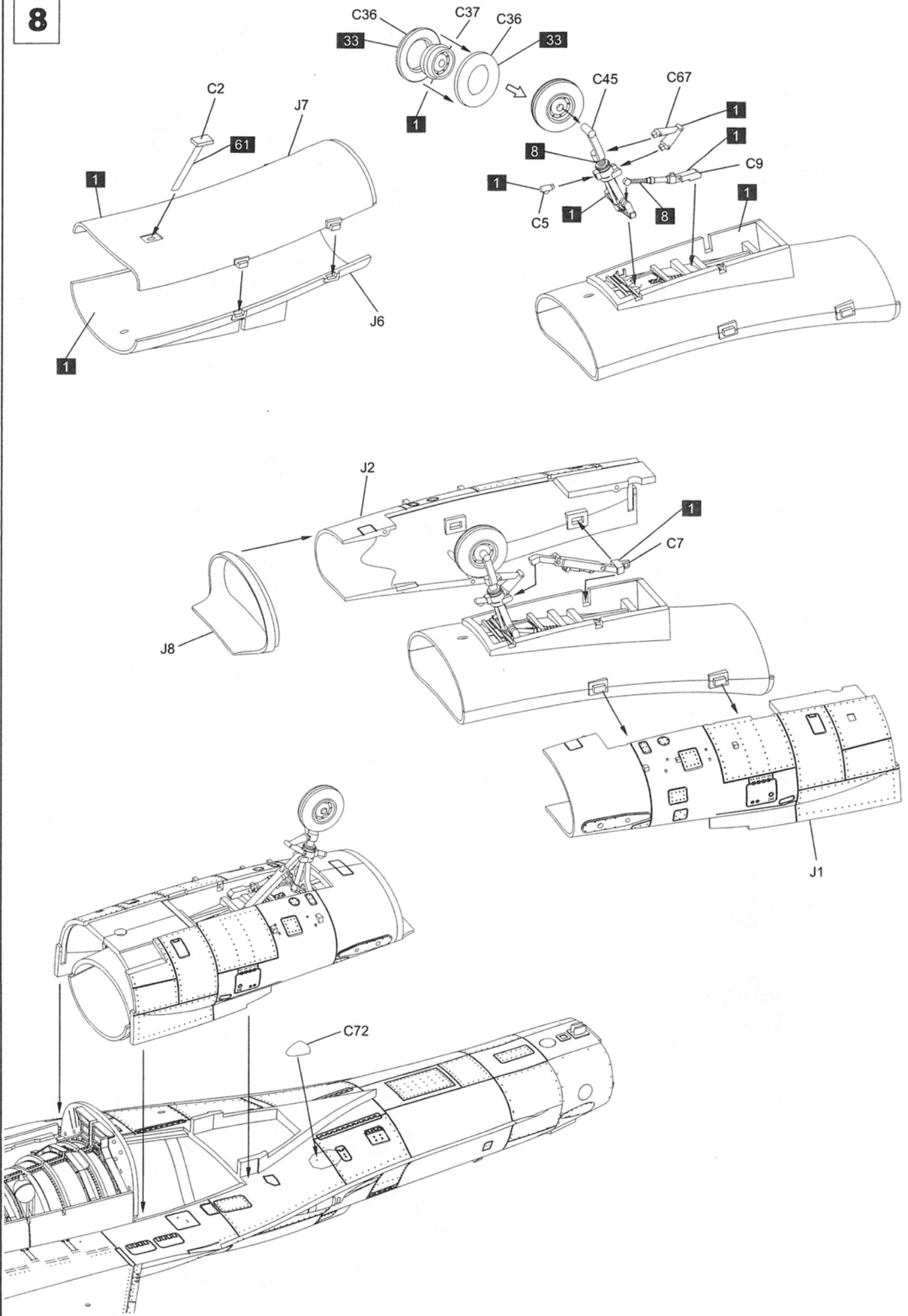

9

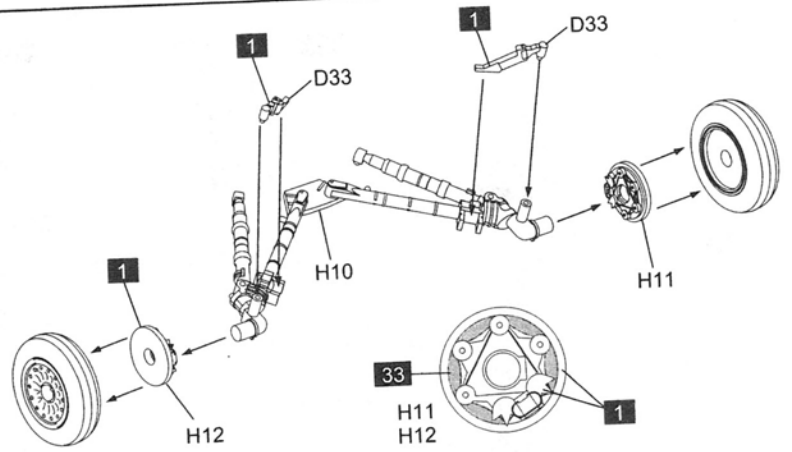
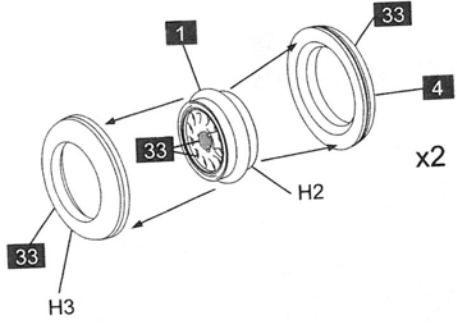

10

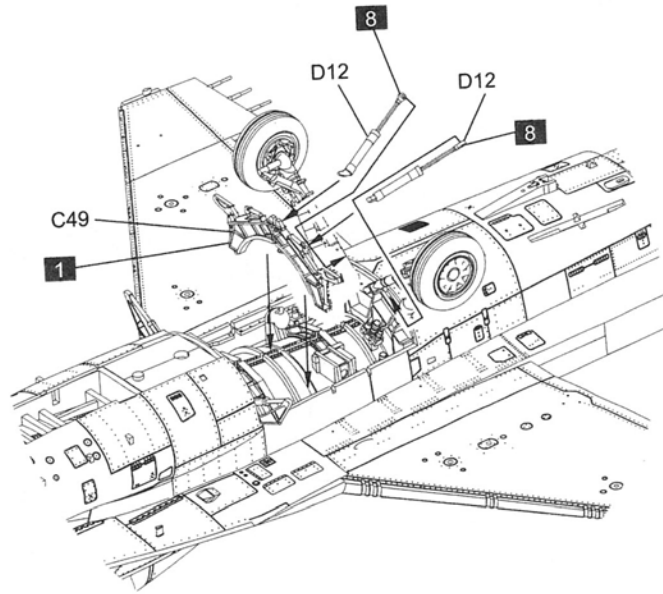
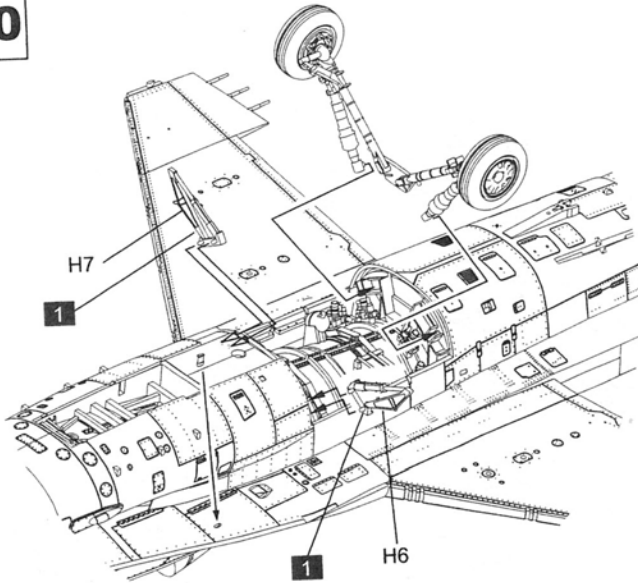

11

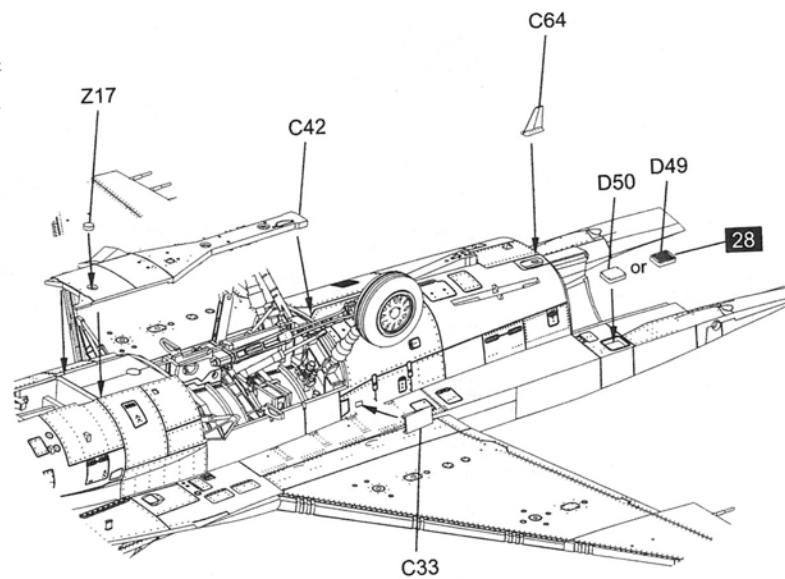
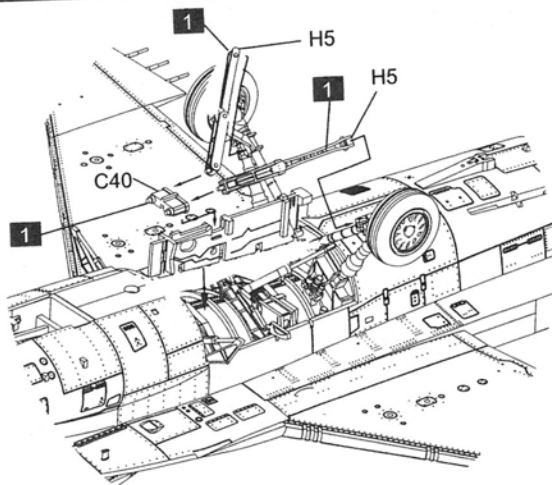

12

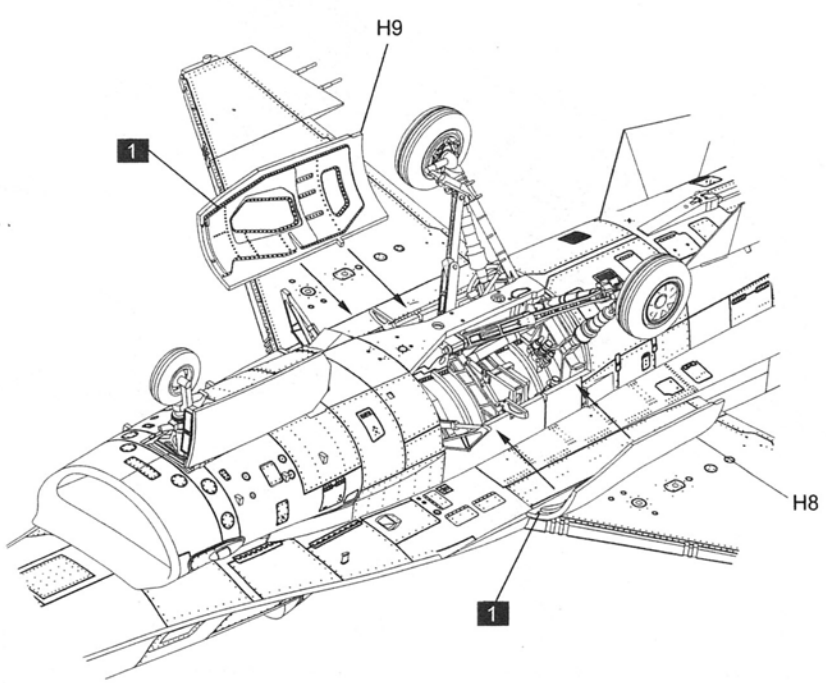
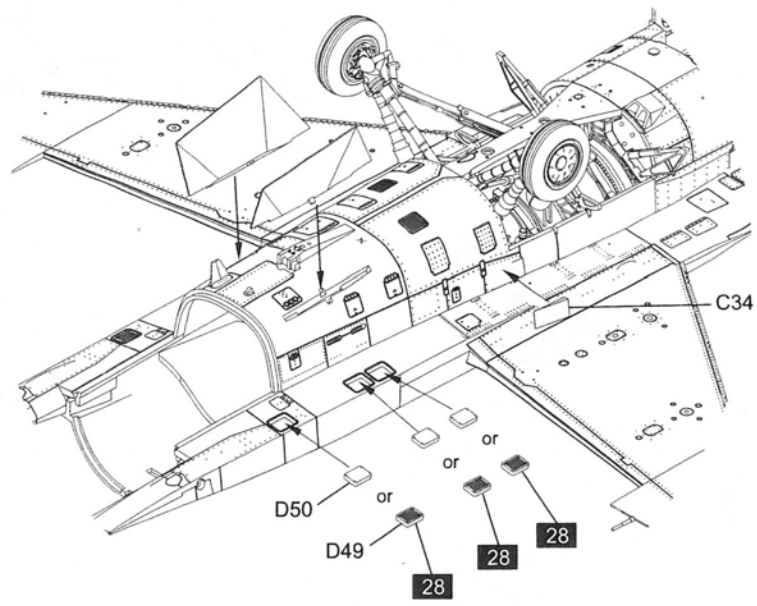
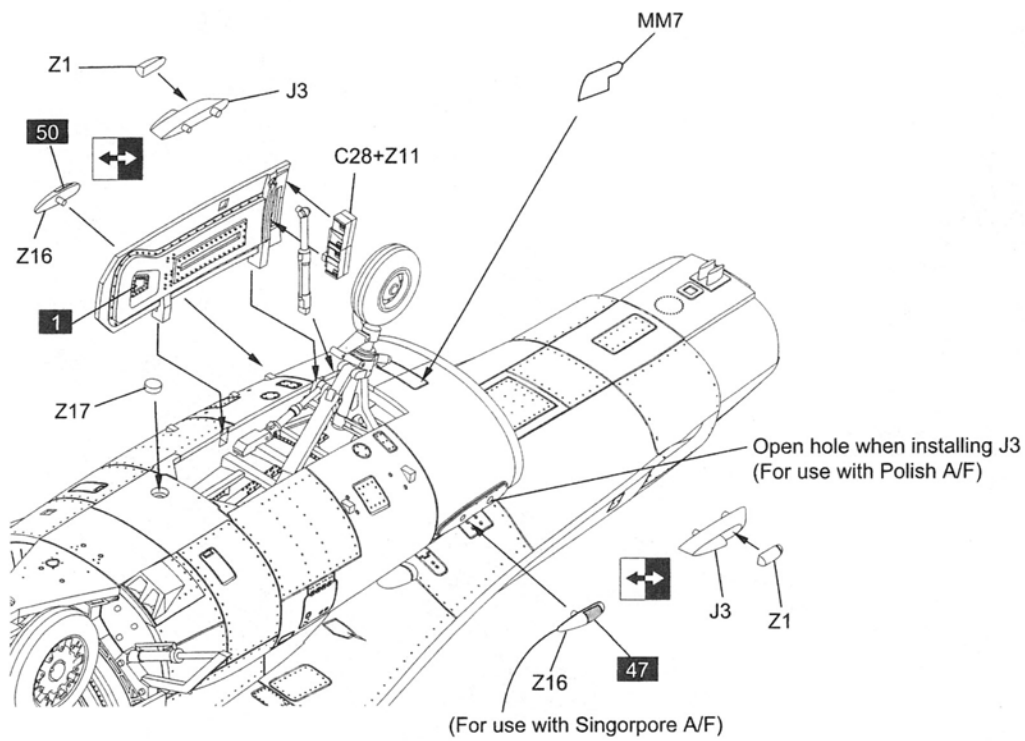

13

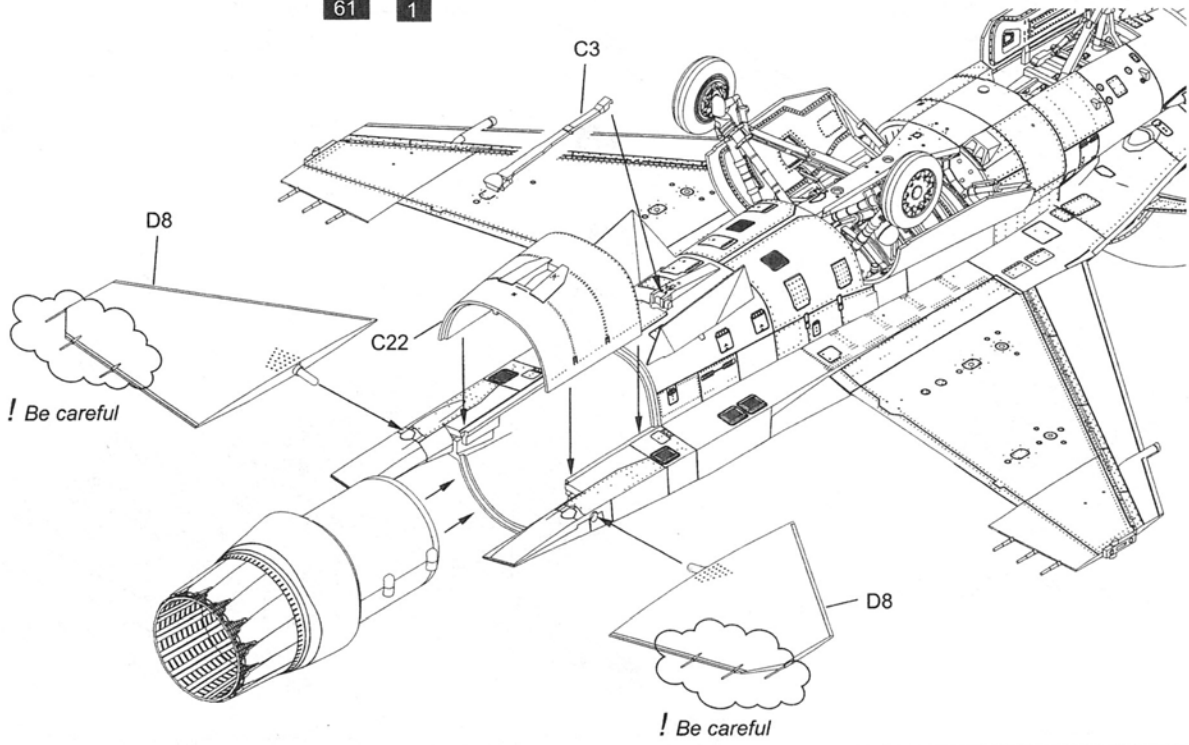
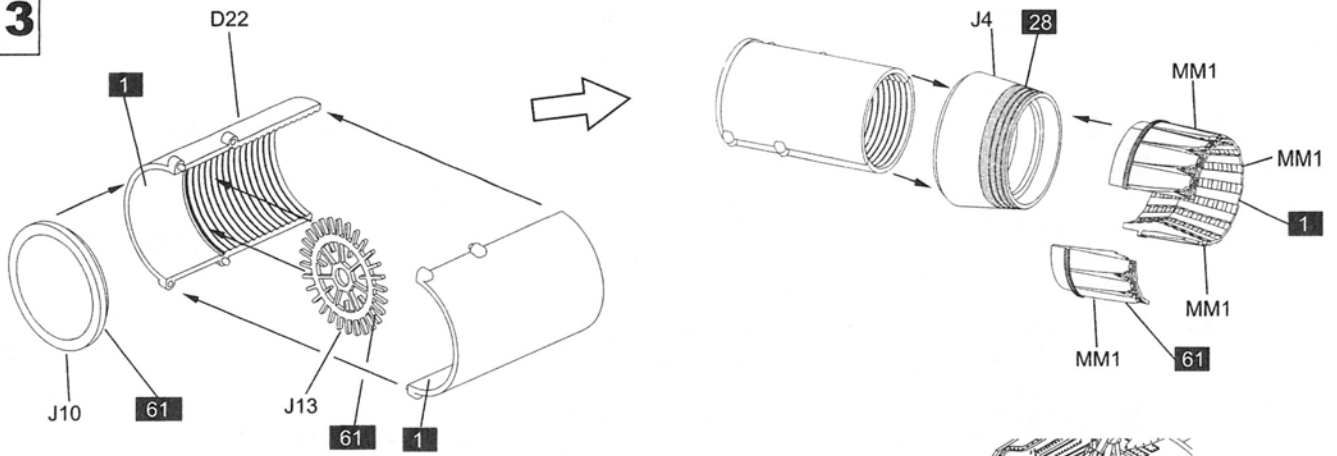

14

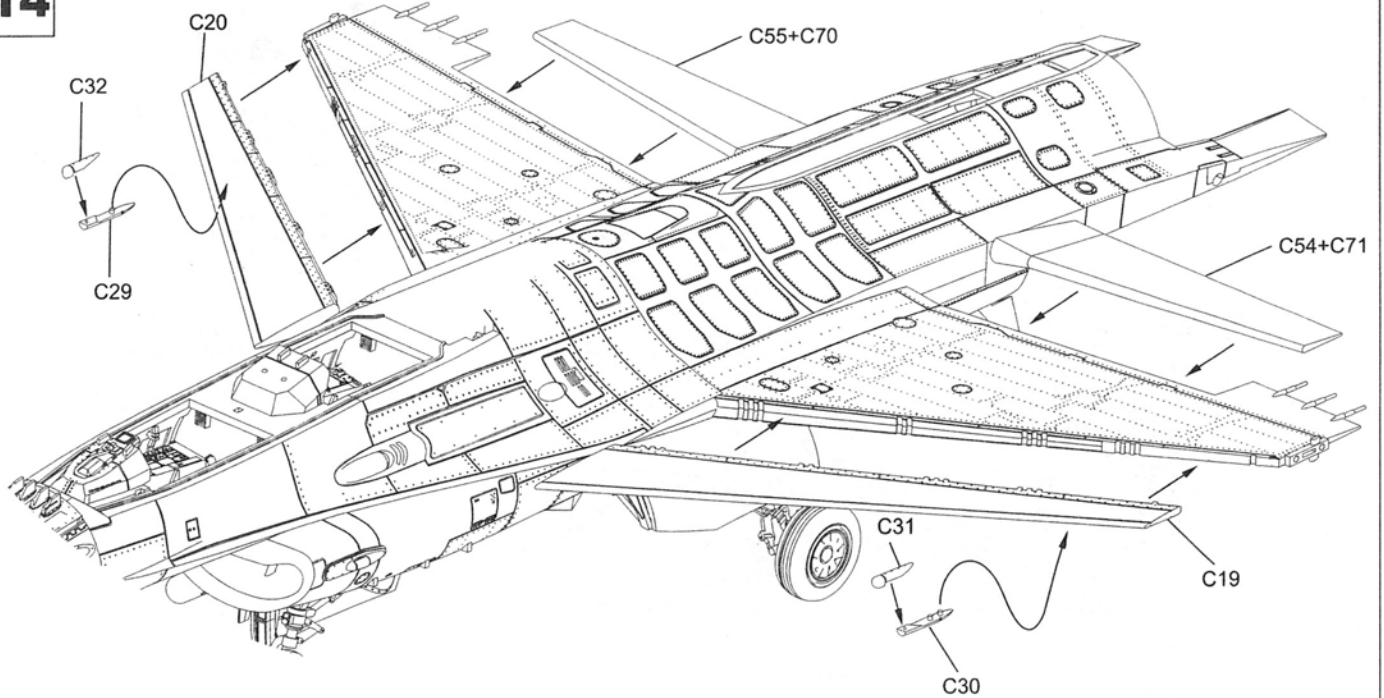

15

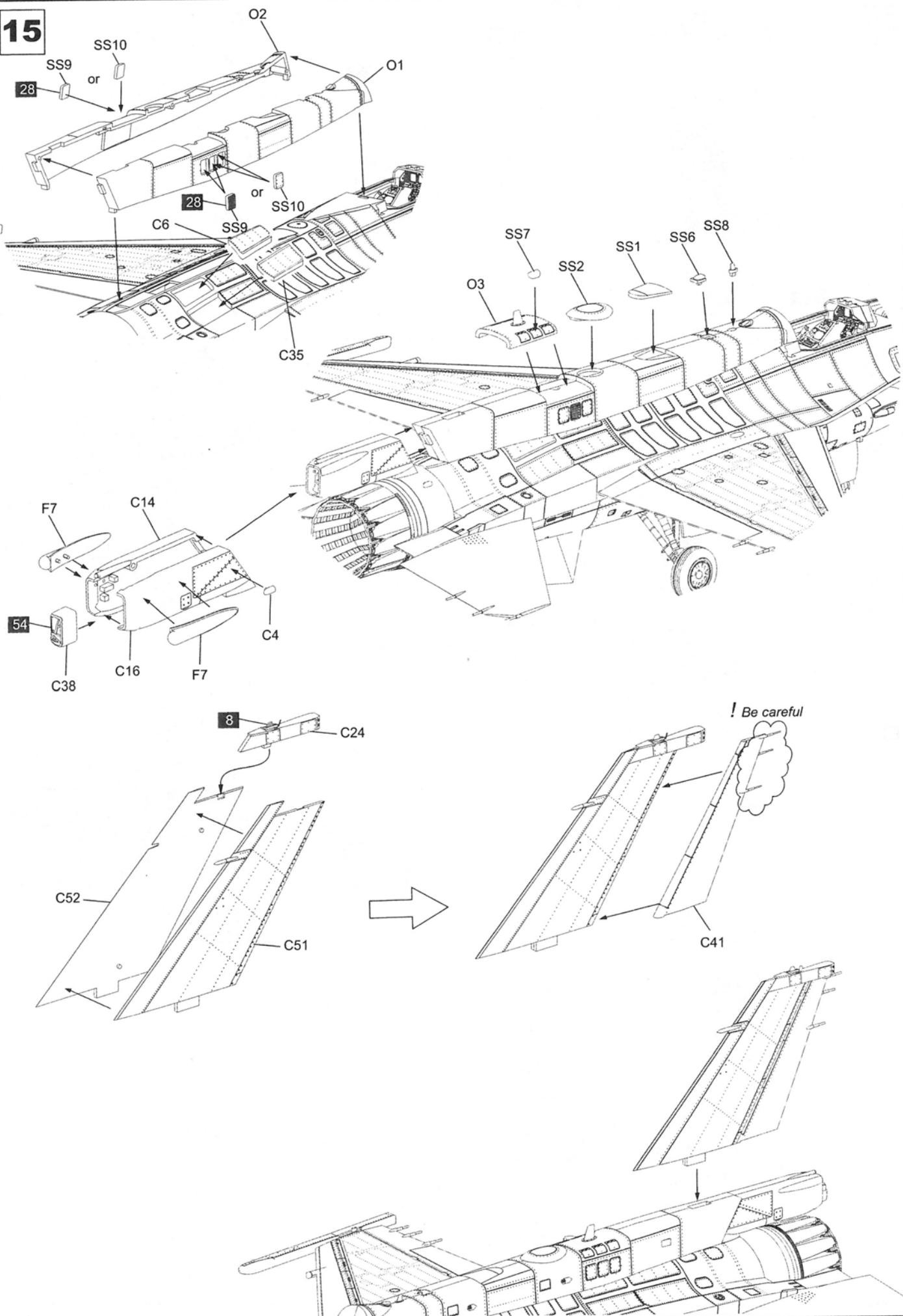

16

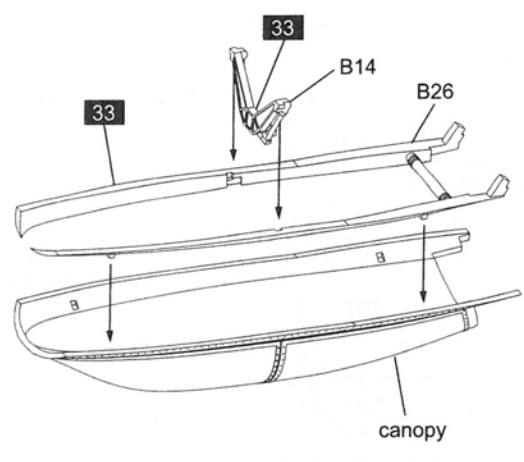
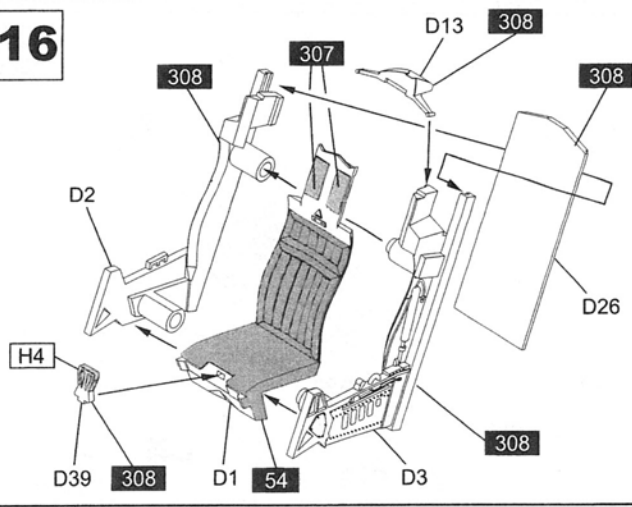

17

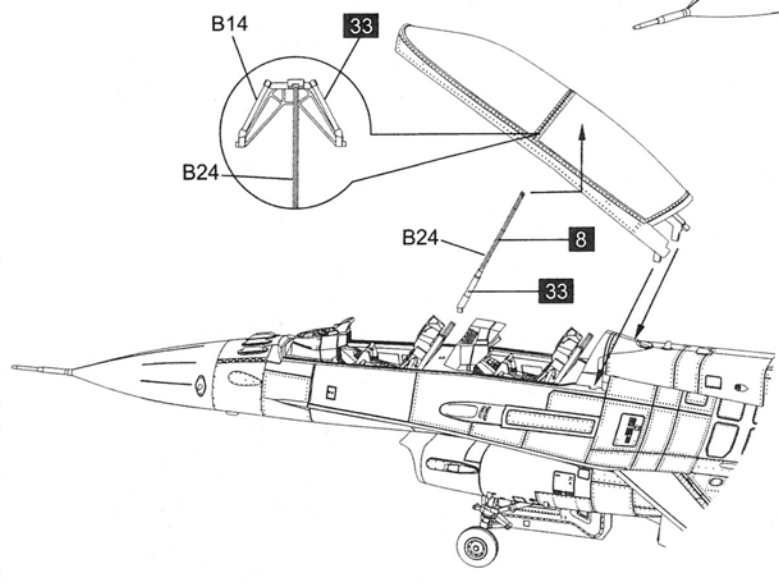
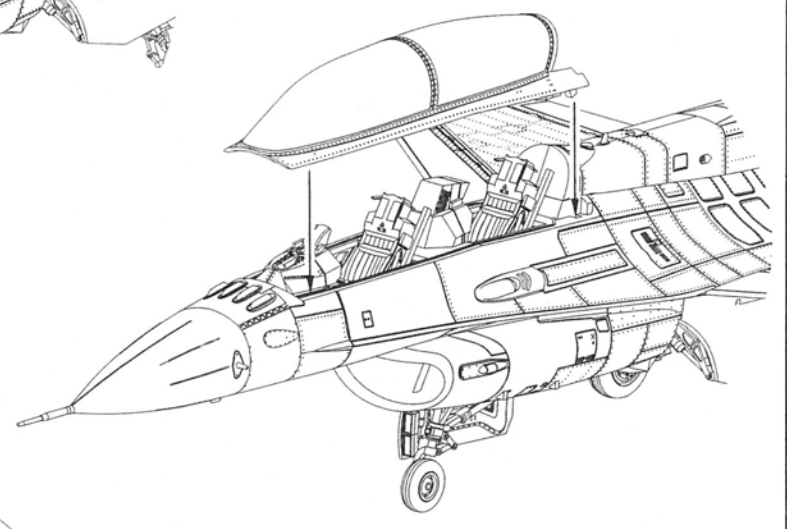
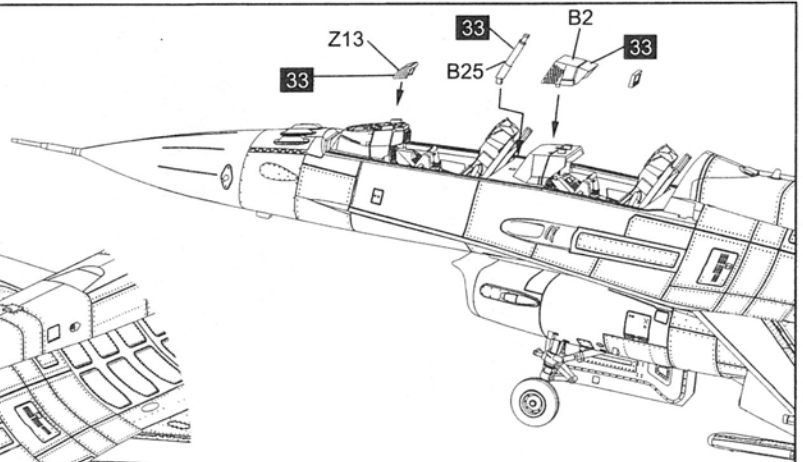
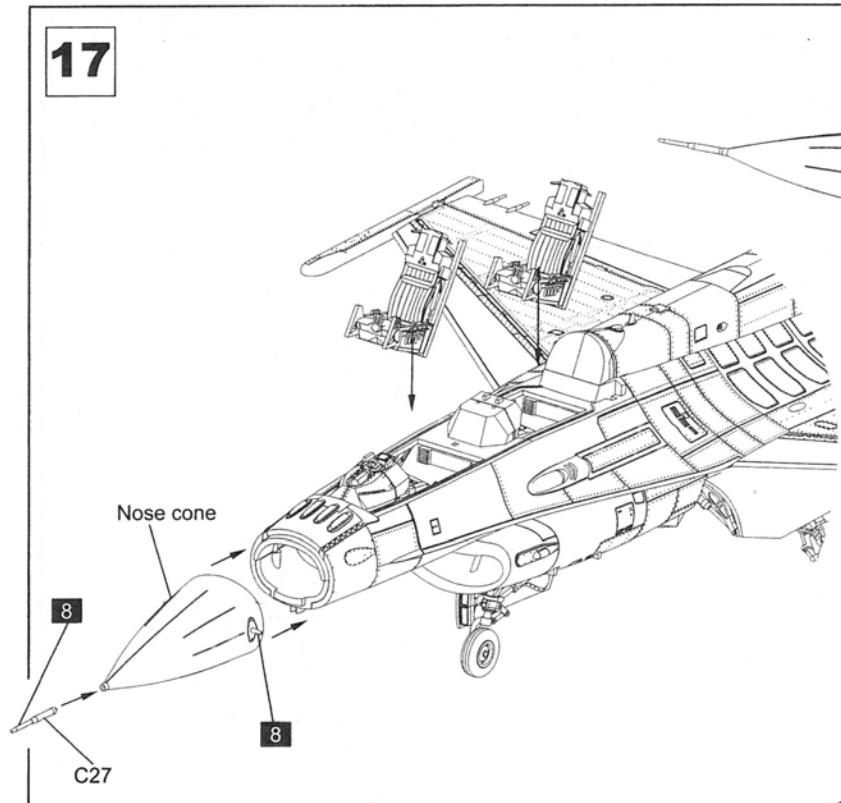

370 Gallon Wing Tank

300 Gallon Centerline Tank

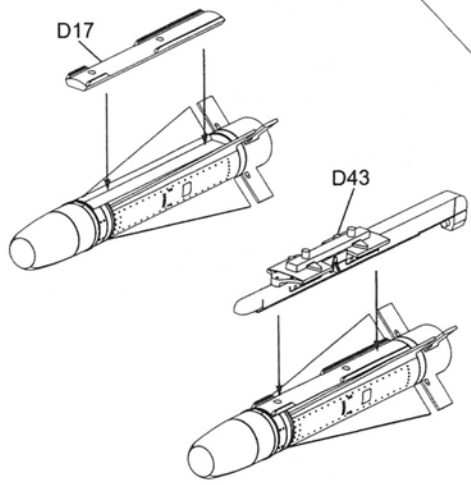
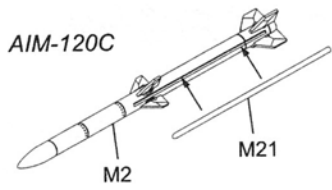
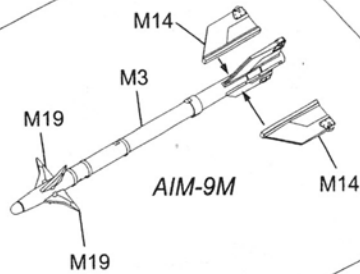
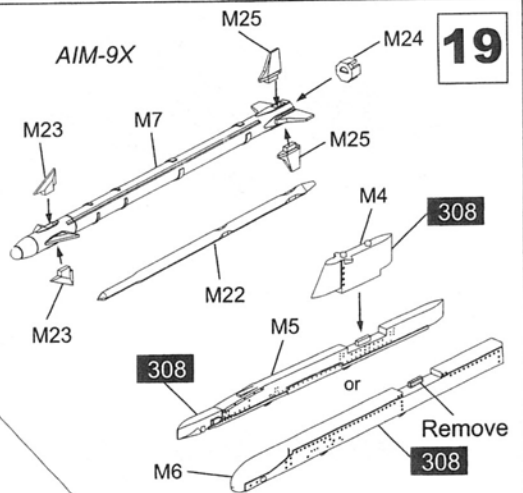
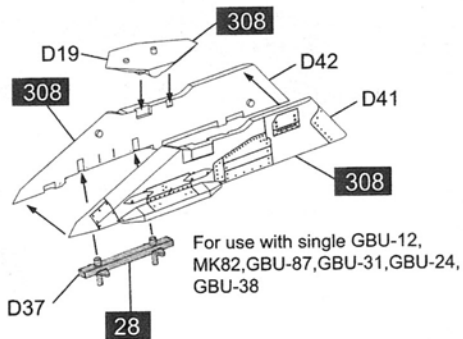
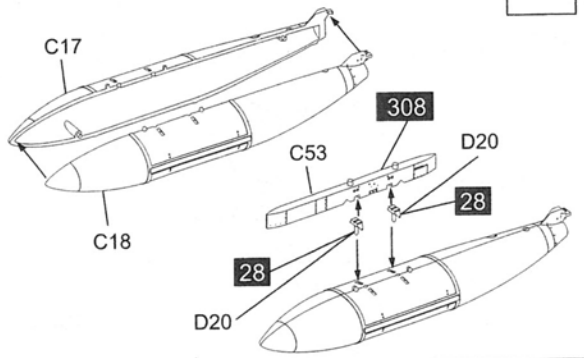
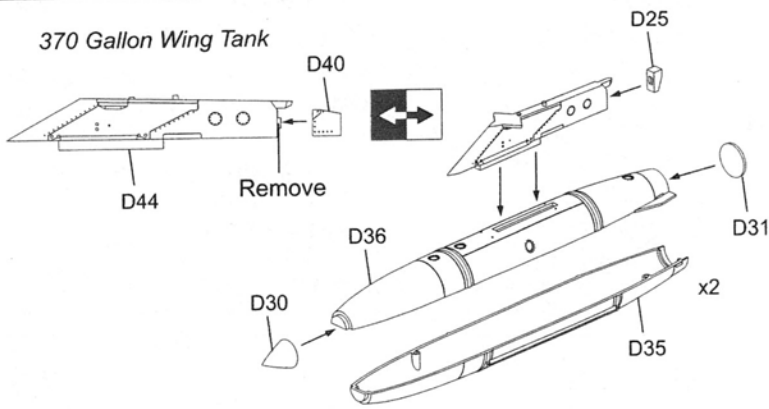

AGM-65

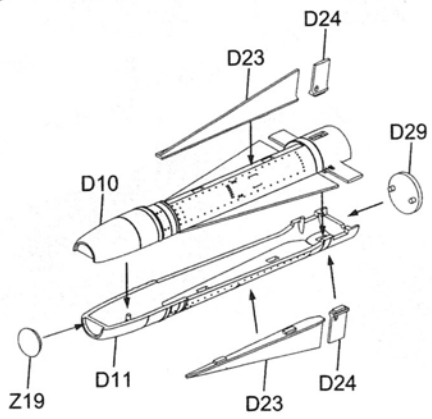

20

MK-82

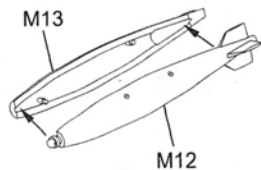

GBU-38

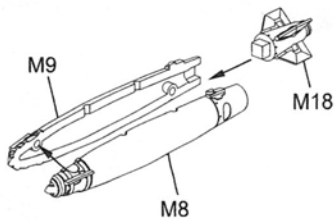

GBU-31

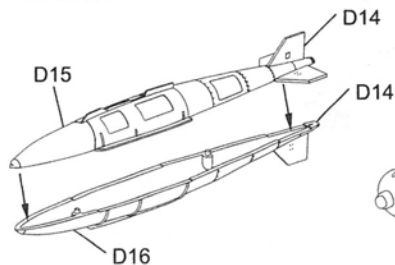

CBU-87

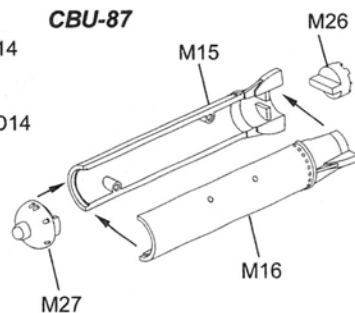

GBU-12

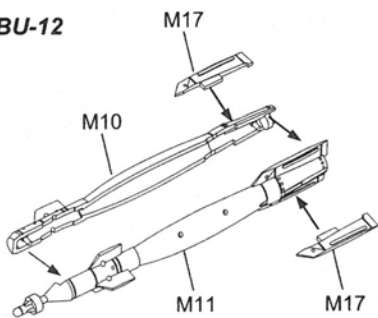

GBU-24

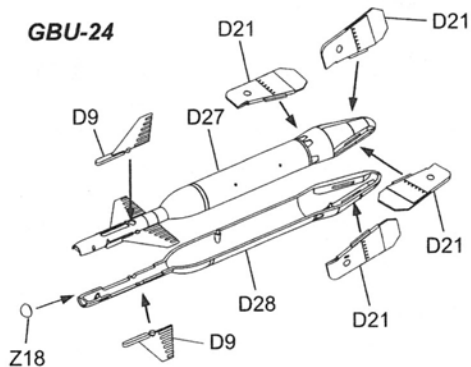

21

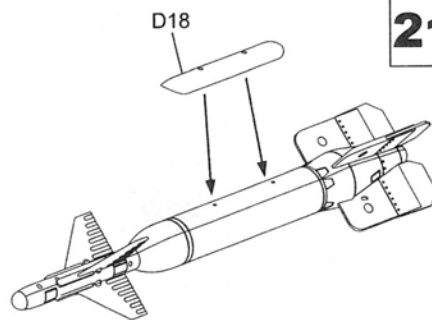

AN/AAQ-13

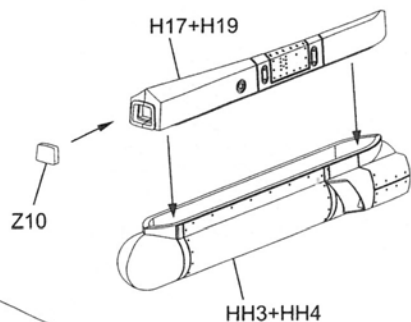

22

TER

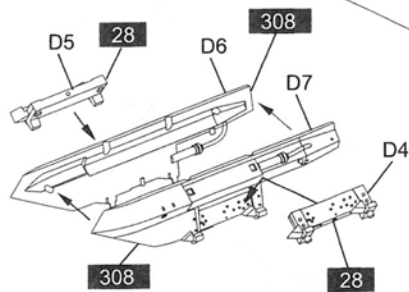

SNIPER XR

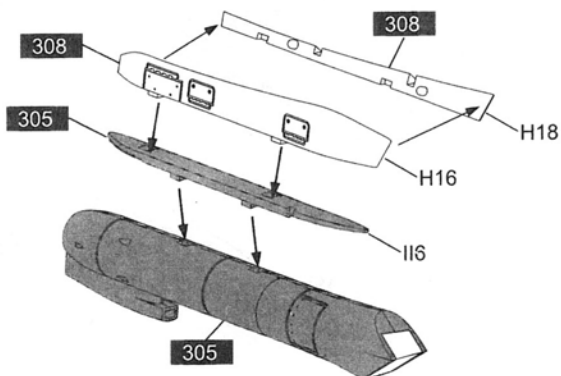
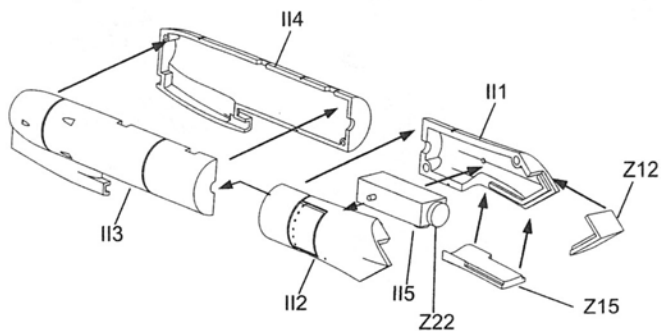

Painting & Decal Placement - External Stores (F-16 C/D)

Fuel Tank

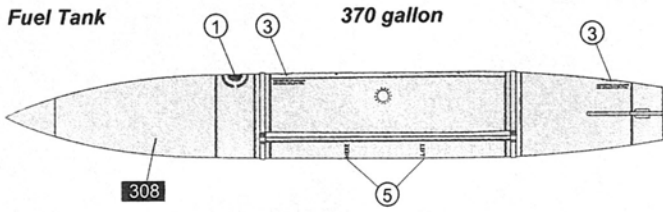

300 gallon

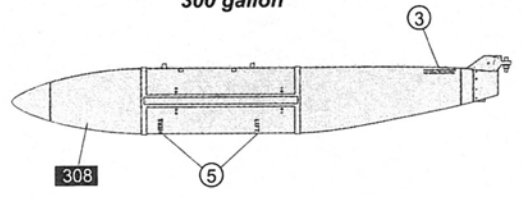

AIM-120C

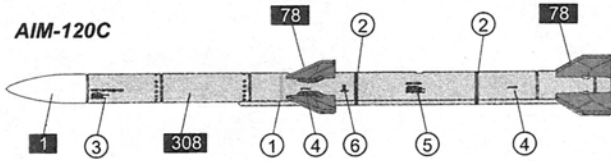

AIM-9M

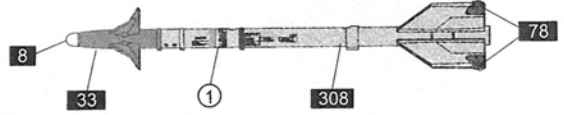

GBU-12

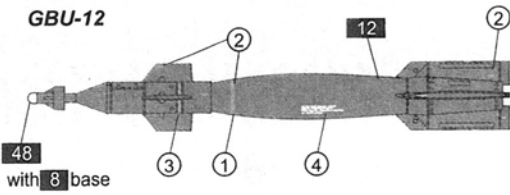

AIM-9X

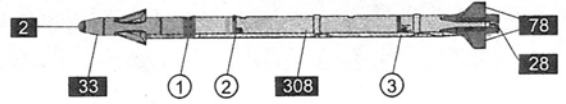

MK.82

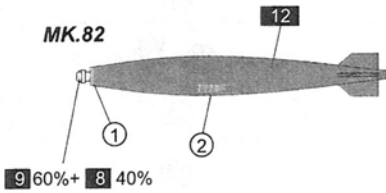

GBU-31

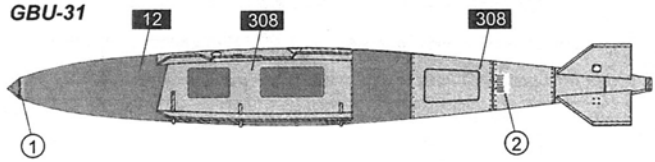

GBU-38

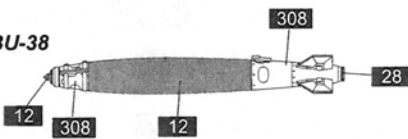

CBU-87

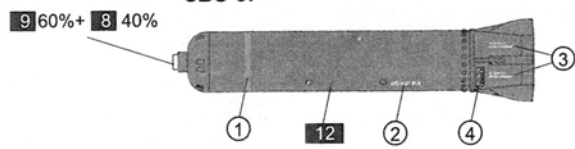

GBU-24

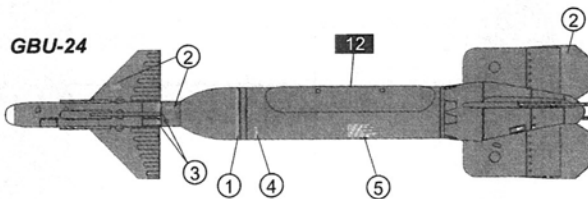

AGM-65

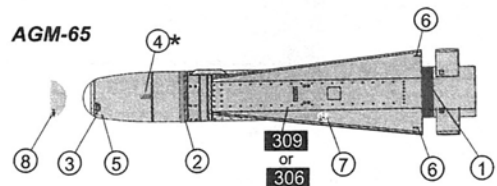

EXTERNAL STORES

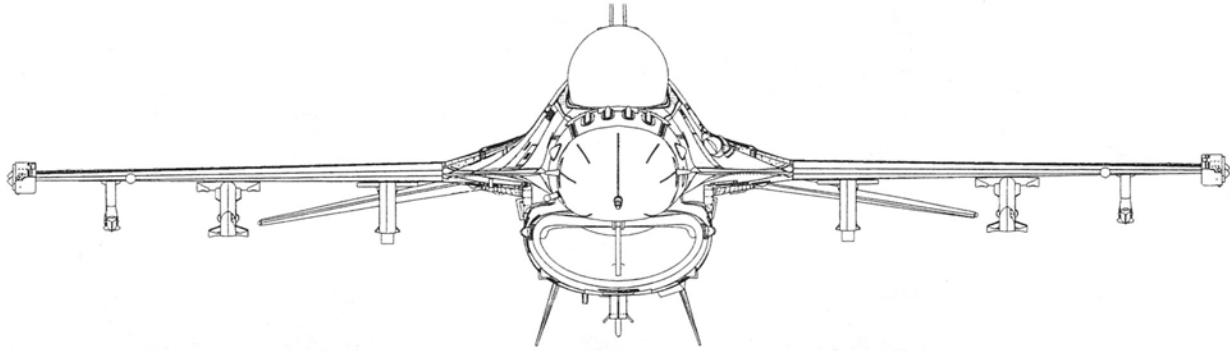

Station No. Weapons	9	8	7	6	5R	5	5L	4	3	2	1
LAU-114 (W/AIM-9M only)	●	●								●	●
LAU-129	●	●								●	●
AIM-9M	●	●								●	●
AIM-9X (W/LAU-129 only)	●	●								●	●
AIM-120C (W/LAU-129 only)	●	●	●						●	●	●
MK.82			●						●		
MK.82 (W/TER)			● ●						● ●		
GBU-12			●						●		
GBU-12 (W/TER)			● ●						● ●		
GBU-31			●						●		
GBU-87			●						●		
GBU-87 (W/TER)			● ●						● ●		
GBU-38			●						●		
GBU-38 (W/TER)			● ●						● ●		
GBU-24			●						●		
AGM-65			●						●		
370gal. Fuel tank				●				●			
300gal. Fuel tank						●					
SNIPER XR					●						

1/48 SCALE AIRCRAFT SERIES NO.09 F-16D BARAK

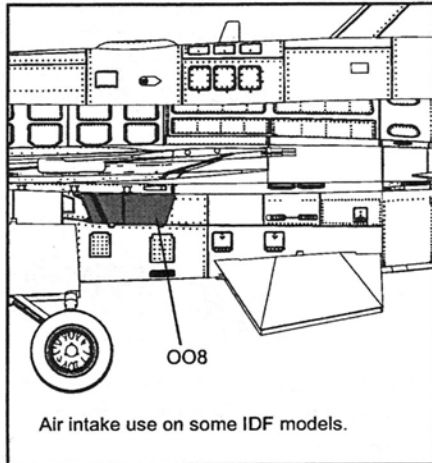
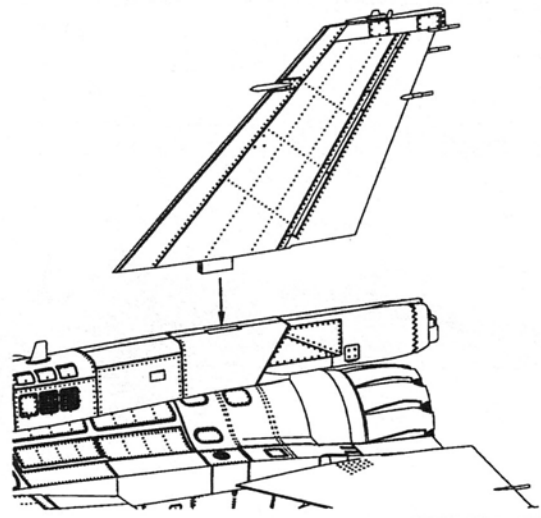
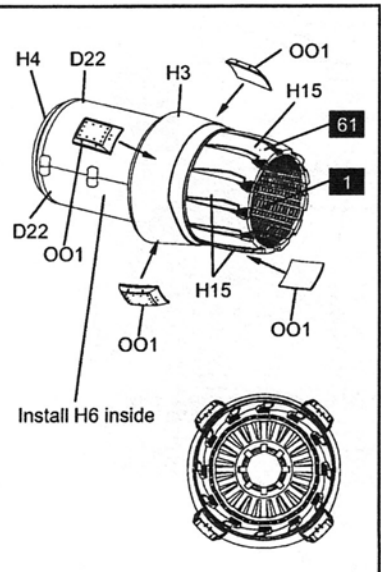
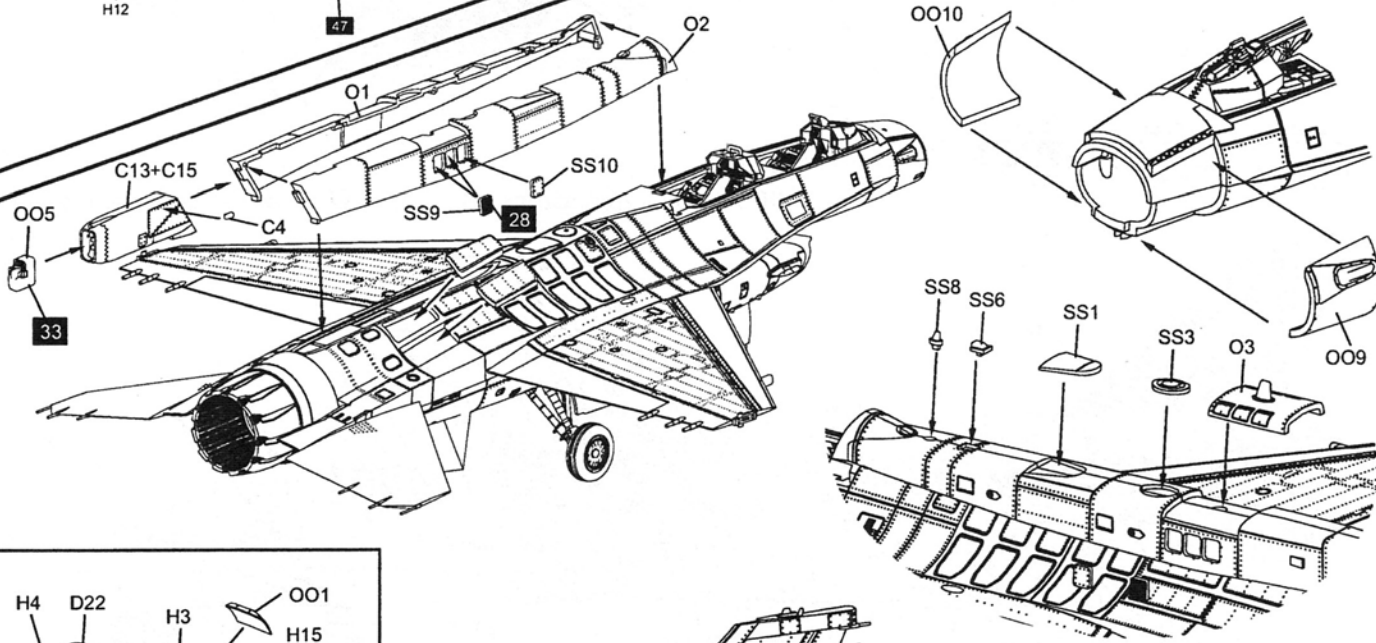
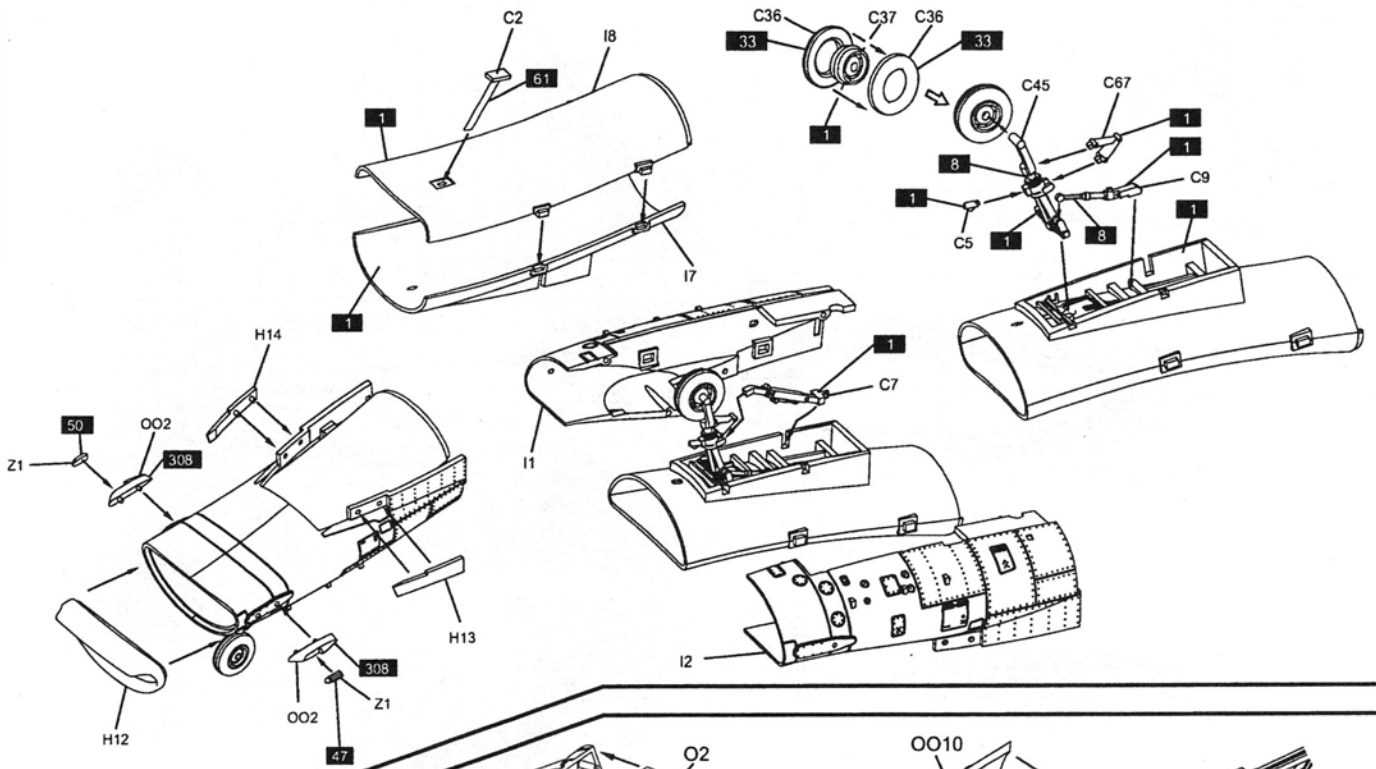

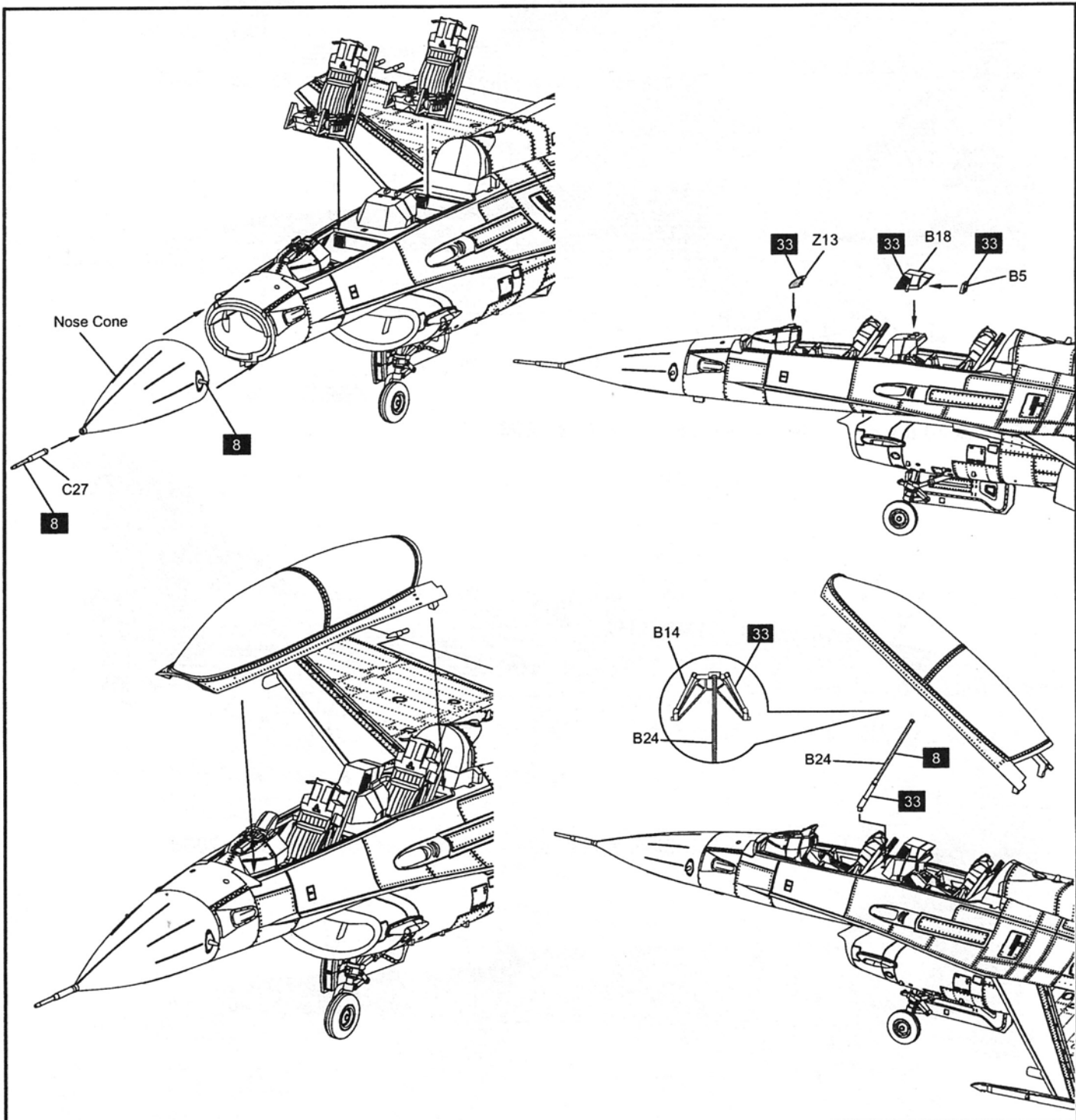
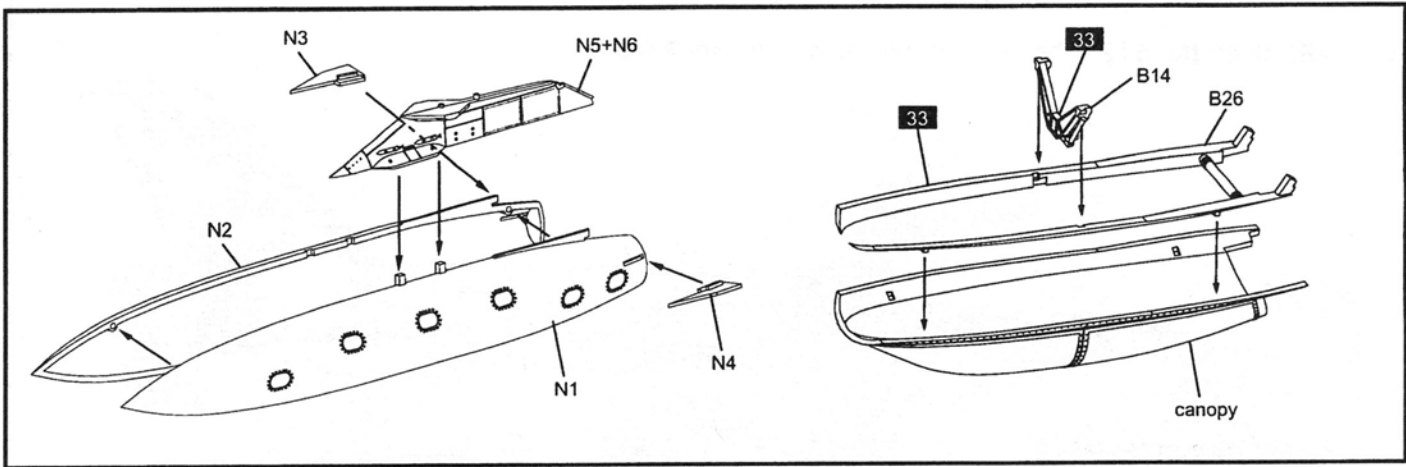

F-16D Block 40 No. 612 - The "Valley" squadron, February 2006

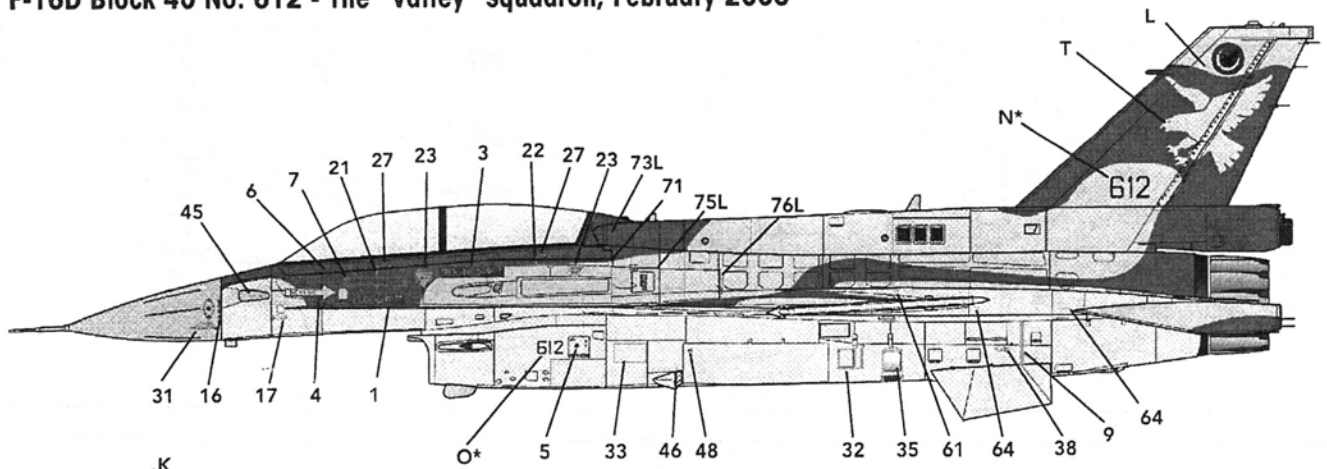

F-16D Block 40 No. 637 - The "Valley" squadron, February 2006

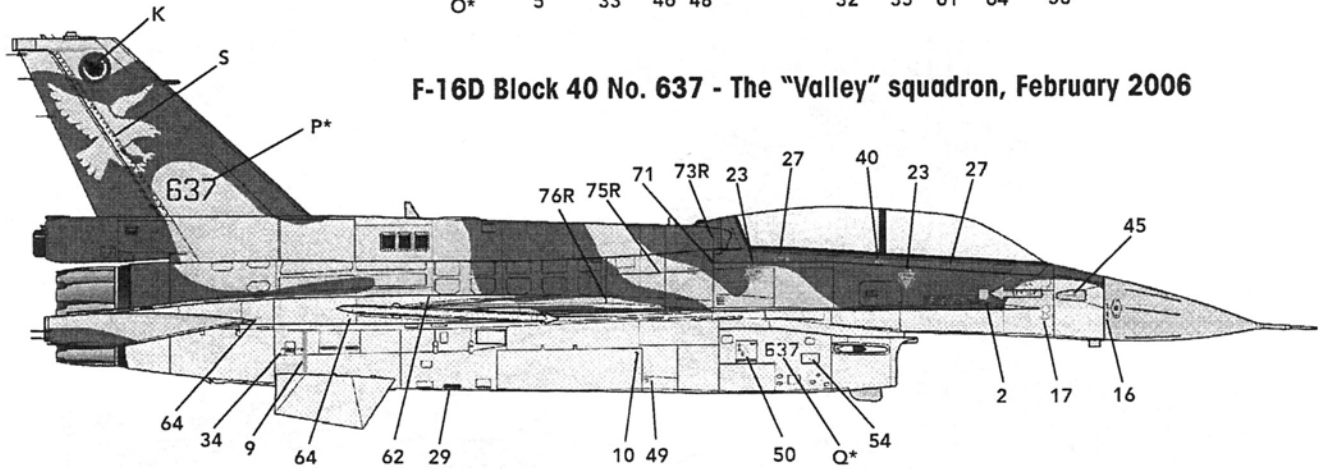

F-16D Block 40 No. 642 - The Scorpion squadron, June 2006

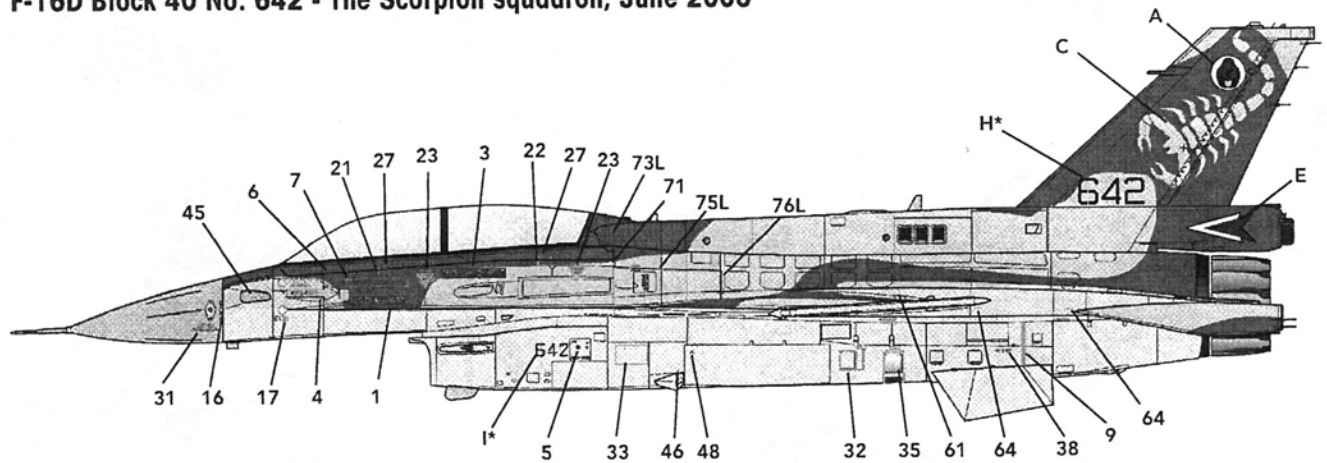

F-16D Block 40 No. 624 - The Scorpion squadron, June 2006

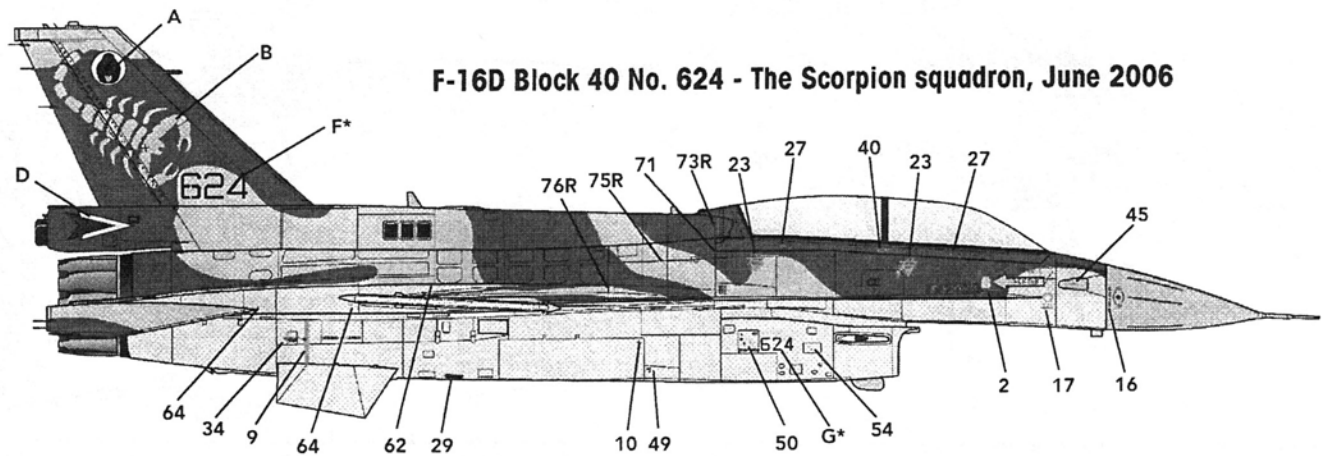

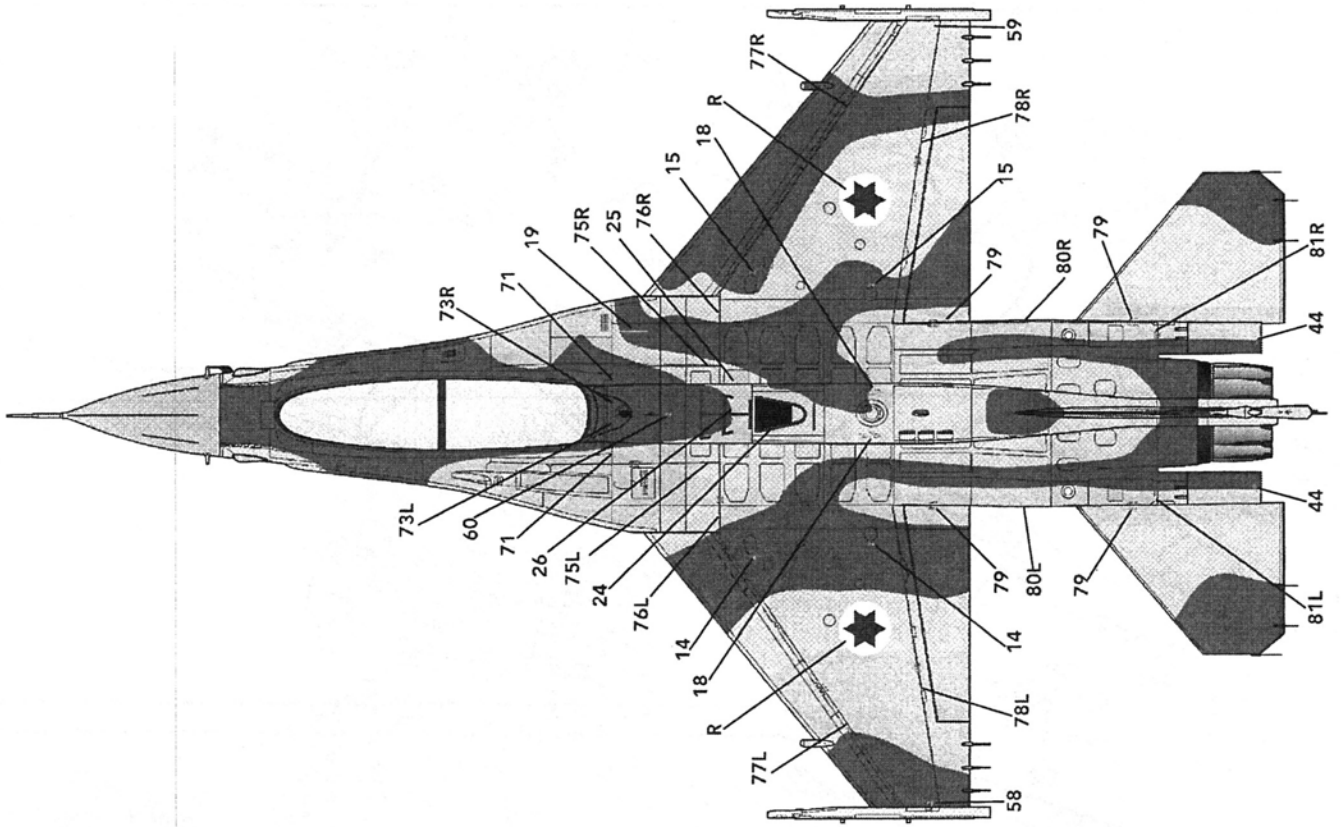

- Sand
 FS 33531
- Green
 FS 34424
- Brown
 FS 30219
- Grey
 FS 36375

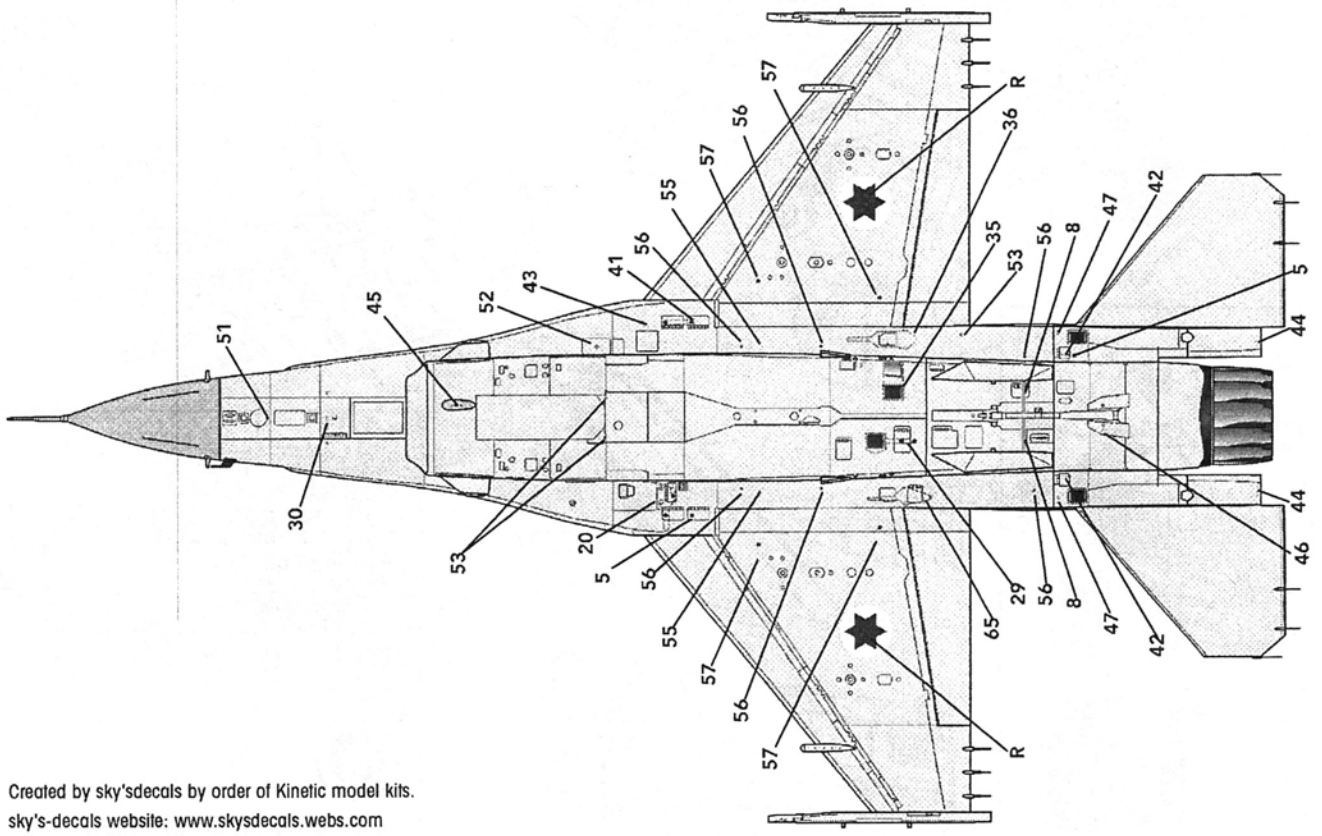

Created by sky'sdecals by order of Kinetic model kits.
 sky's-decals website: www.skysdecals.webs.com
 Decals design by: Netanel Deri