

LOCKHEED P-2H(P2V-7) NEPTUNE

1/72 Scale Series

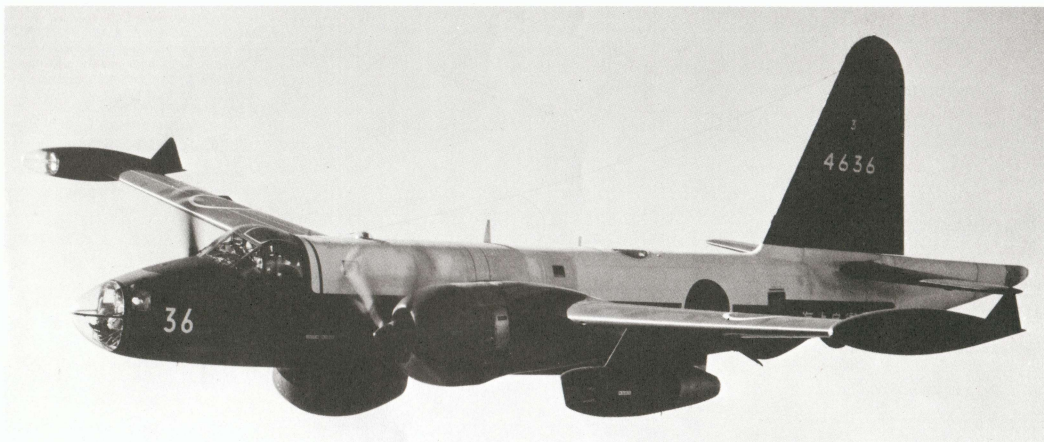

<P-2 J>

History

The original model of this anti-submarine patrol plane for a long range was first designed in 1944, with its successful maiden flight on May 17, 1945. Until now it has been the front line patrol plane, and through the numerous and major improvements it was very active in many countries.

The P-2H (P2V-7) was the last model, appearing in 1954. In 1946, the original XP2V-1 patrol plane set a world record on long distance rectilinear flight and was considered as one of the masterpieces of that time. Because of the advancement on the submarines and anti-submarine warfare, this plane was mainly used for submarine patrol. The long magnetic detector (MAD) is extended to the back of the fuselage, mammoth radar dome below the fuselage, ECM, wing tip with 70 thousand candle power searchlight, sonar buoy, the bomb bay loaded with torpedo, bombs, rockets for submarine attack. This plane is able to patrol for many hours, from 12 to 18 hours, without refueling. The 20% wing thickness manifests satisfactory aerodynamical efficiency, and by the device on the horizontal stabilizer, the half of which is movable, it maintains proper maneuverability during the speed and gravity change of a wide range.

After the Model 5, two J34 jet engines (fuel identical to the main engine) were installed, to improve the take-off and landing performance



<P-2 J>

enlarged and the engine replaced with the turbo-prop. The 4 blades propeller was changed to 3 blades one, and the auxiliary engine was changed to the domestic J3-8. In the landing gear the single wheel was changed to dual wheels (smaller size). The shape of the vertical tail and the space area on the rudder became larger. The radar dome became very compact.

However, rather than the outer appearance the more important point was the change on the anti-submarine armaments, the P-2J was equipped with the modern ones. The engine output became smaller than the P2V, but with its remodeling the entire weight became 4.5 tons lighter and performance increased considerably. Until the next jet anti-submarine plane PX-L is completed, this P2V-7 will still be the major force for the Japanese Maritime Self Defence Force.

Data

Engine: Right R-3350-32WA, 3,750Hp x 2 + Westinghouse J34WE, 1,542kg. x 2 / Overall Width: 30.89m / Overall Length: 27.94m / Overall Height: 8.94m / Wing Area: 92.9m² / Dead Weight: 30,618kg. / Rate of Climb from Sea Level: 770m/min. Maximum Speed: Mach 0.47 / Service Ceiling: 7,620m / Cruising Range: 7,400km / Armament: Torpedo x 4, or 150kg. Bomb x 16, 127mm Rocket x 8

Turbo-Prop Engine

10% of the effective power remains in the injected gas and by the remaining 90% the propeller is powered, which is the principle of the gas turbine engine. The 10% of the effective power, in the injected gas, is utilized in the form of driving force. This engine satisfactory for take-off, because of its great driving force at low speed, but because of the propeller drive it can not deliver the maximum flight speed. Recently this engine has made inroad upon the engine for light planes, because of its low price and economy that solves one of the various problems.



<P-2 J>

ance and to elevate the speed during the fight action and furthermore to increase its stability. Because of its special type of duty, the demand for greater cruising range and all weather performance, these equipments and crew facilities were well established. But on the other hand the high altitude performance was not up to expectation. This plane was the main force for the Japanese Maritime Self Defence Force for anti-submarine patrol. With the P2V-7 as the nuclear, it was remodeled to equip with the latest anti-submarine armaments. The remodeled plane became the domestic made Kawasaki P-2J. It is 1.3m longer than the P2V-7, the interior space

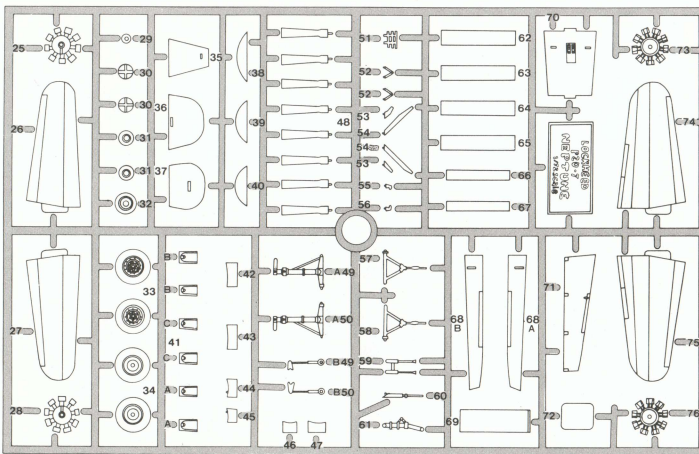
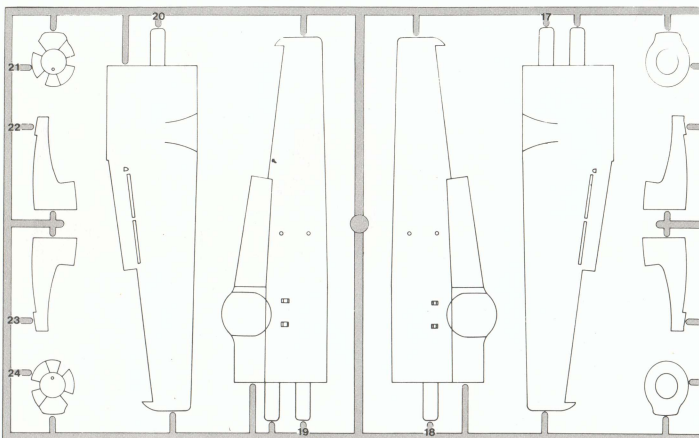
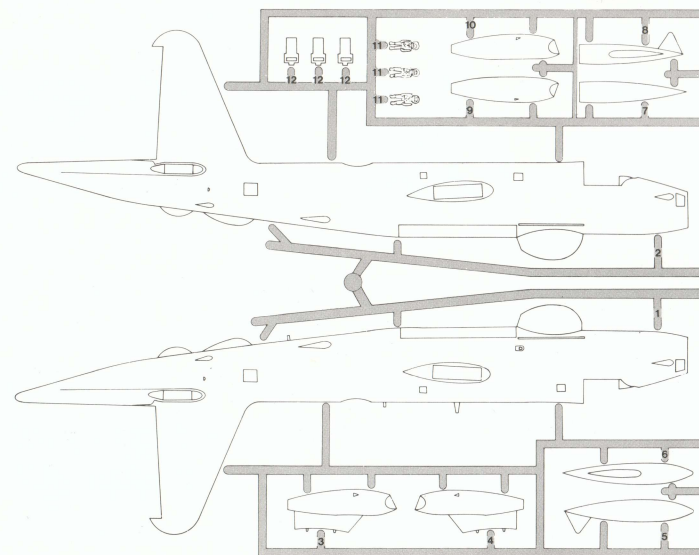

Parts

1. Fuselage (left)
2. Fuselage (right)
3. Jet Engine (left) (outer side)
4. Jet Engine (right) (outer side)
5. Wing Tip Auxiliary Fuel Tank (left)
6. Wing Tip Auxiliary Fuel Tank (right)
7. Searchlight (right)
8. Searchlight (left)
9. Jet Engine (left) (inner side)
10. Jet Engine (right) (inner side)
11. Pilot
12. Seat
13. Cowling
14. Engine Nacelle (right)
15. Engine Nacelle (left)
16. Cowling
17. Main Wing Top (left)
18. Main Wing Bottom (left)
19. Main Wing Bottom (right)
20. Main Wing Top (right)
21. Engine Bracket
22. Engine Nacelle (right)
23. Engine Nacelle (left)
24. Engine Bracket
25. Engine (back)
26. Horizontal Tail Wing Bottom (left)
27. Horizontal Tail Wing Bottom (right)
28. Engine (back)
29. Searchlight Reflector
30. Spinner (back)
31. Spinner (front)
32. Nose Wheel
33. Landing Wheel (outer side)
34. Landing Wheel (inner side)
35. Nose Floor
36. Bulkhead (back)
37. Bulkhead (front)
38. Instrument Panel
39. Main Wing Top Parts
40. Main Wing Top Parts
41. Exhaust Pipe (A) (B) (C)
42. Cowling Flap (C)
43. Cowling Flap (C)
44. Cowling Flap (A)
45. Cowling Flap (B)
46. Cowling Flap (B)
47. Cowling Flap (A)
48. Propeller
49. Landing Gear Parts (A) (B)
50. Landing Gear Parts (A) (B)
51. Nose Parts
52. Oleo
53. Antenna (B) (left, right)
54. Antenna (A) (left, right)
55. Pitot Tube (left)
56. Pitot Tube (right)
57. Landing Gear Parts (A) (left)
58. Landing Gear Parts (A) (right)
59. Automatic Cannon
60. Nose Wheel Strut
61. Nose Wheel Chassis
62. Landing Gear Hatch Door (right, inner side)
63. Landing Gear Hatch Door (right, outer side)
64. Landing Gear Hatch Door (left, outer side)
65. Landing Gear Hatch Door (left, inner side)
66. Nose Wheel Hatch Door (left)
67. Nose Wheel Hatch Door (right)
68. Aileron (A) (left), (B) (right)
69. Front Wheel Case
70. Cockpit Floor
71. Rudder
72. Cannon Mount
73. Engine (front)
74. Horizontal Tail Wing Top (left)
75. Horizontal Tail Wing Top (right)
76. Engine (front)
77. Canopy (B) (left)
78. Canopy (C) (left)
79. Canopy (C) (right)
80. Canopy (D) (right) (left)
81. Canopy (B) (right)
82. Canopy (E)
83. Cockpit Canopy (right)
84. Observation Window
85. Searchlight Front Parts
86. Nose Canopy
87. Automatic Cannon Cover
88. Canopy (A) (right)
89. Canopy (A) (left)
90. Cockpit Canopy (left)

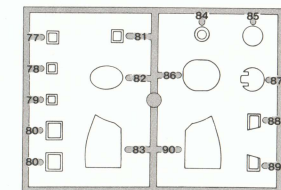

1 Cockpit Assembly

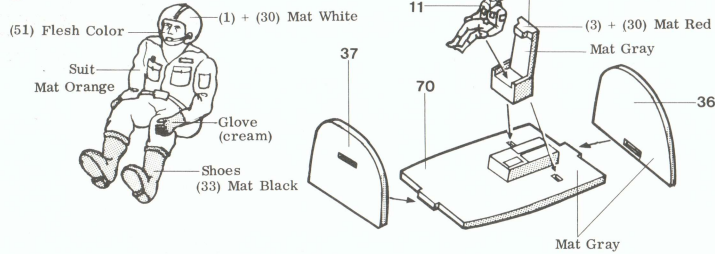

2 Fuselage Assembly

For U.S. Navy Model, fit on the automatic cannon 72, 59 and 87.

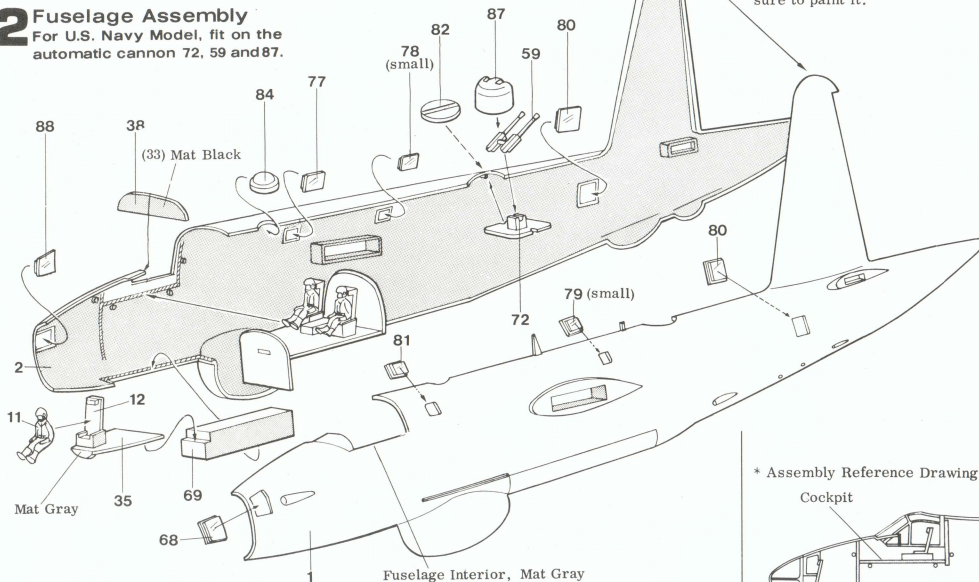

Place a weight, about 30 grams, in front of the fuselage.

3 Engine Assembly

Make 2 sets.

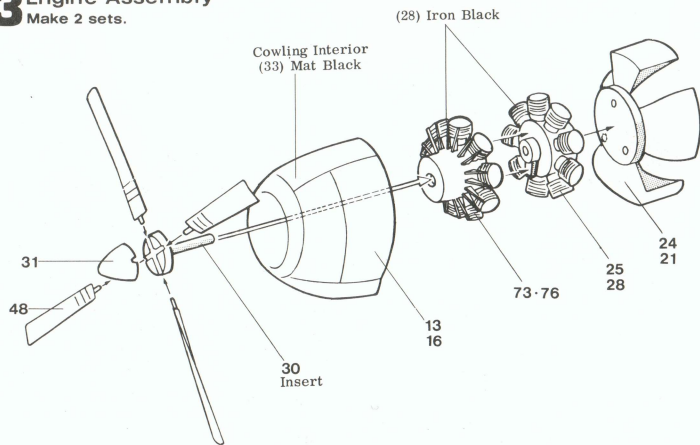

Read This before Assembling

* Carefully read the instructions before assembling your model and follow them.

* Carefully cut off the parts from the stem with a knife or a clipper.

• After removing the parts from the bag, cut it in pieces and throw it away ... to prevent the infant from covering its head.

• Precautions in Handling the Adhesive
1. Keep it away from infants, and do not use it other than for cementing.
2. Keep away from fire.
3. Do not deliberately inhale it.

Model Color

The model colors are from (1) - (60). After the model is completed, be sure to paint it.

* Assembly Reference Drawing

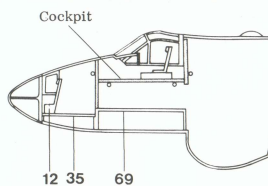

* Reference Drawing on Painting the Propeller

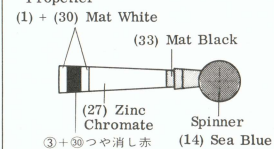

4 Main Wing, Tail Wing Assembly

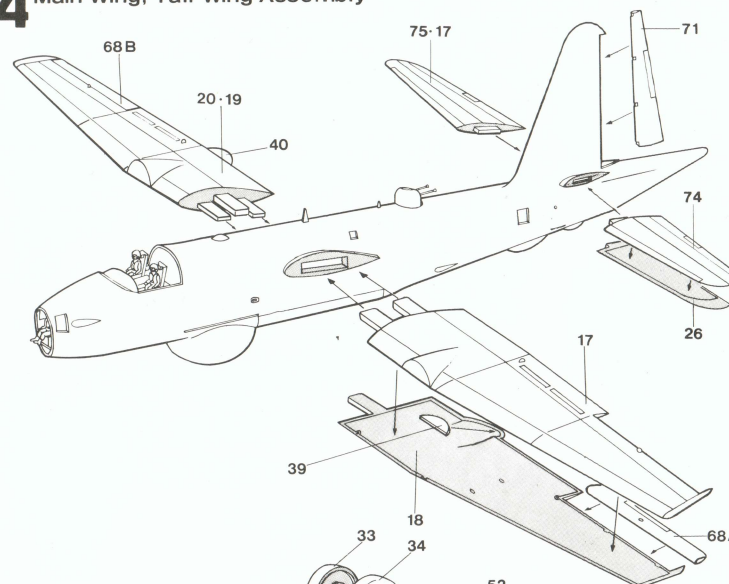

5 Main Landing Gear Assembly (left side)

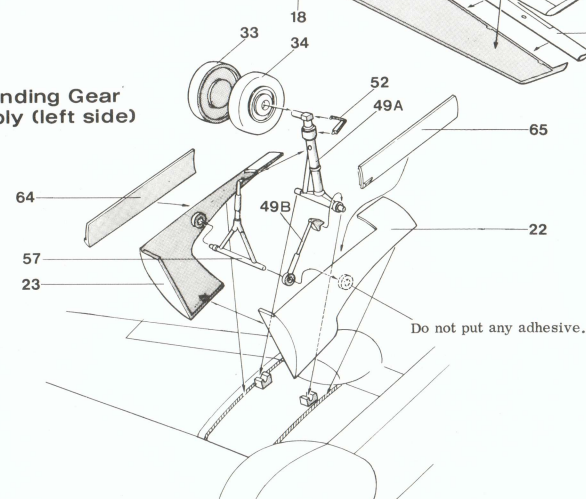

6 Main Landing Gear Assembly (right side)

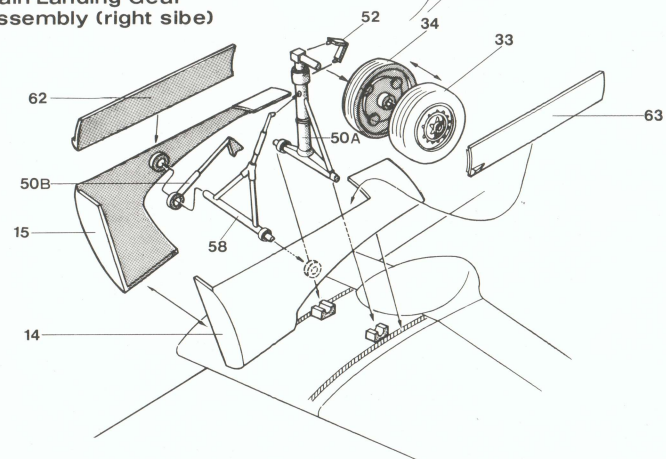

Actual Plane P-2V

Drawing-5

Insert 57 to retainer part on 22, 23 (do not cement), and then cement 22, 23. Cement 49 to the main wing bottom and at the same time cement the assembled engine nacelle 22, 23 to the main wing bottom.

Painting Reference

Tire (33) Mat Black
Wheel (8) Silver
Landing Gear, Torque Link (8) Silver
Landing Gear Cover, Interior (1) + (30) Mat White

Drawing-6

Insert 58 to retainer on 14, 15 (do not cement), and then cement 14, 15. Cement 50 to the main wing bottom and at the same time cement the assembled engine nacelle 14, 15 to the main wing bottom.

Reference Picture of Propeller



7 Nose Wheel Assembly

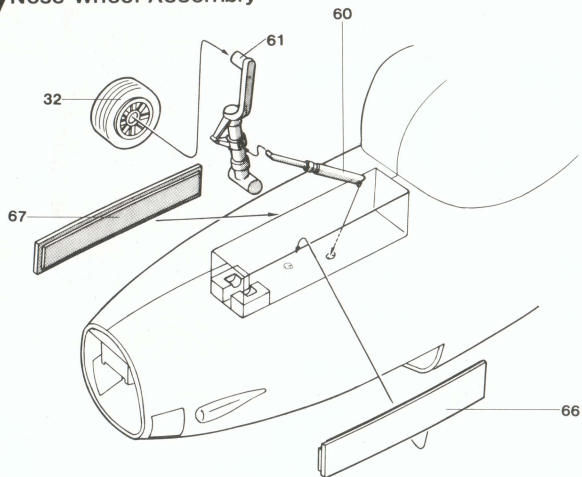

* Reference on Painting
 Tire (33) Mat Black
 Landing Gear (8) Silver

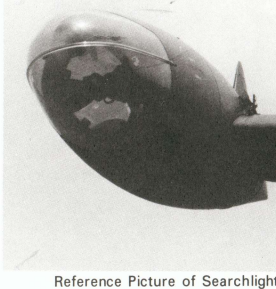

8 Exhaust Pipe, Cowling Flap Assembly (right side, the same)

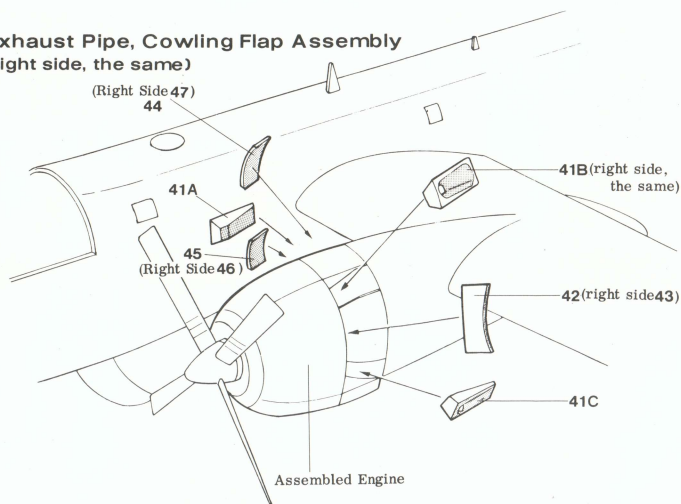

* Reference Drawing on Exhaust Pipe Fitting

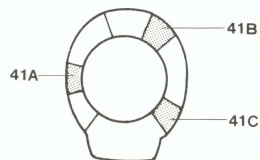

* Reference Drawing on Cowling Flap Fitting

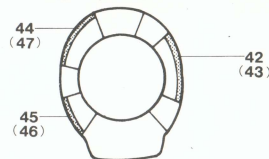

Reference Picture

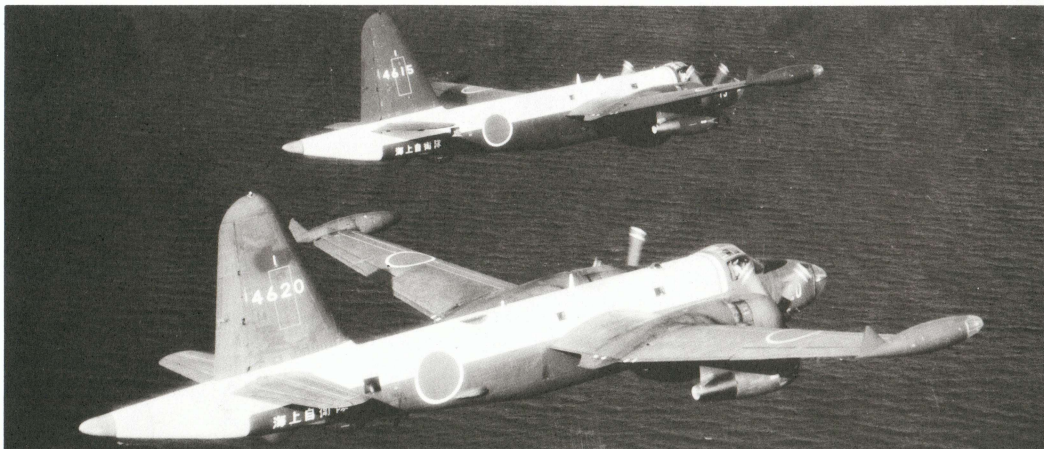

9 Engine, Auxiliary Fuel Tank Assembly

Assemble 2 sets.

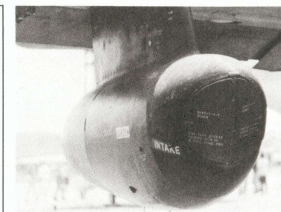
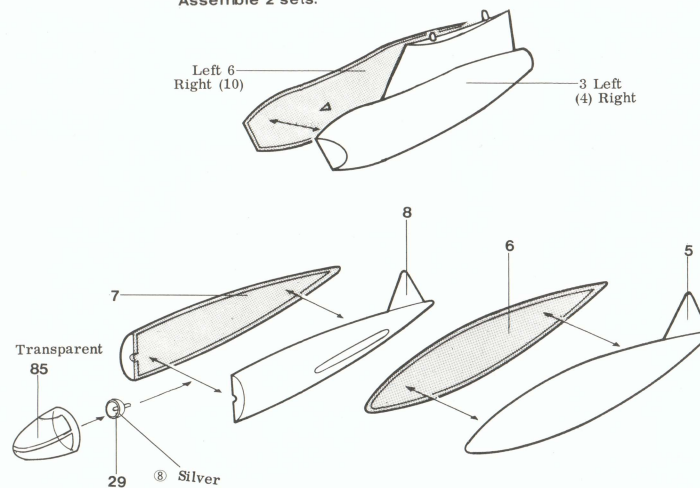

Engine (P-2J) Reference Picture



Radar Dome (P-2J) Reference Picture

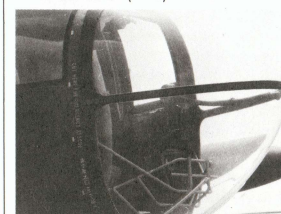

Nose (P-2J) Reference Picture

10 Parts Fitting

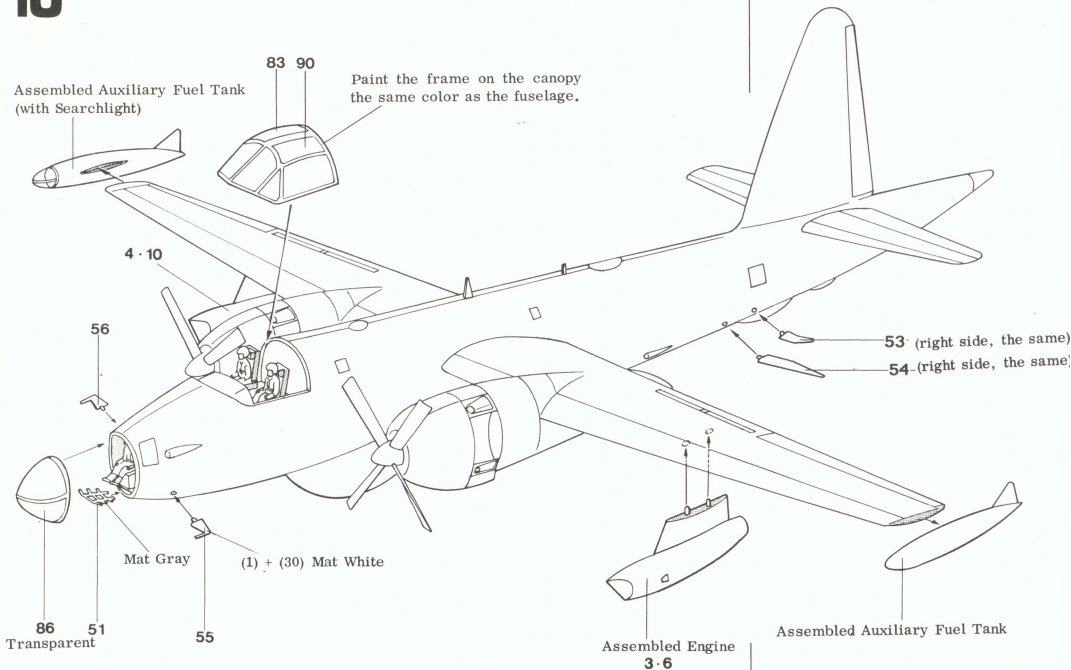

Marking & Color Painting Guide

Applying Decals

1. Wipe and clean the area, where the decal is to be positioned, from dust or oiliness with a wet rag.
2. Cut out the decal and remove the film covering.
3. Place in lukewarm water, transfer the decal when the paper becomes flat.
4. Slide off the decal from the paper and position it at the proper place.
5. Press the transferred decal with a soft cloth, to adhere to the model and to remove the excess moisture.
6. Do not touch the decal until it is well dried.

Model Color

The number for the model colors is from (1) - (60). After the kit is assembled, paint the necessary colors.

Main Colors to be used

- (14) Sea Blue (Navy Blue) Entire Fuselage
- (1) White Mat white for fuselage top, interior of landing gear cover.
- (33) Mat Black Tire, Engine
- (30) Flat Base Adaptive for mat color, use for mat finish on original color.
- (8) Silver Landing Gear, Wheel, etc.

Other Colors for Accentuation

- (3) Red Mat finish for headrest, propeller, etc.
- (27) Zinc Chromate Propeller
- (28) Iron Black Engine, Automatic Cannon, etc.
- (51) Flesh Color Pilot

To paint a wide area, use a flat brush; for pilots and other small parts use a thin brush. After the painting, be sure to wash the paint brush in paint thinner.

U.S. Navy 1st Patrol Squadron

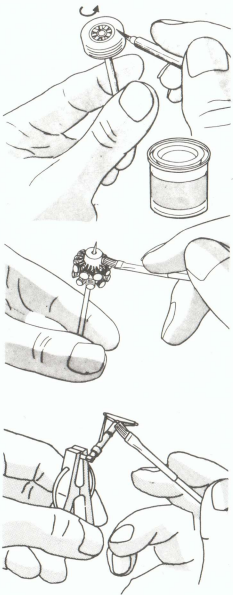
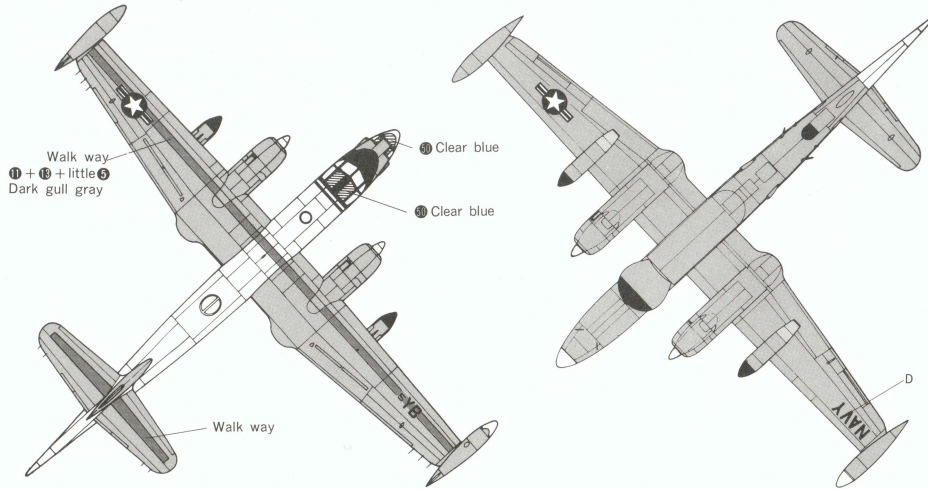
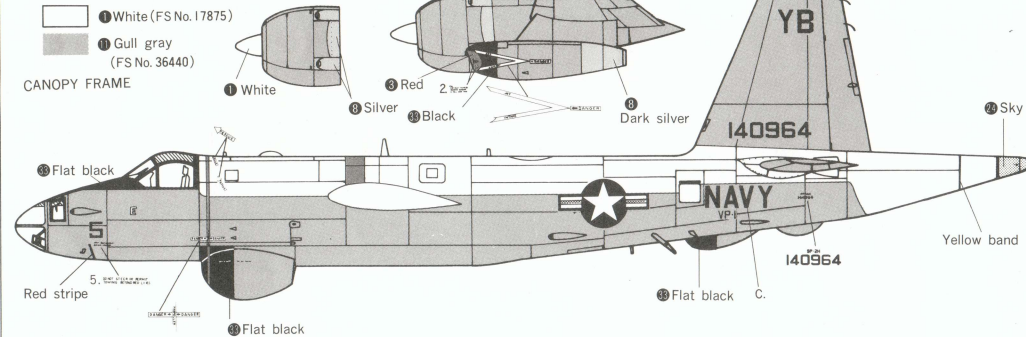

Wheel Painting

After the left and right wheel are cemented, and the burrs and rough adhesive are corrected, paint it. Insert a toothpick into the shaft hole, rotate it and paint. Stick the toothpick into a lump of putty for drying.

Engine Painting

Since it is difficult to paint the engine correctly while it is still on the stem, remove it from the stem and insert a toothpick and paint. Paint it completely with black; then slightly splash a silver tint.

Landing Gear Chassis Painting

On small parts without a hole, grip the piece with a clip or a laundry clip and paint. Paint the parts lightly and go over it about 2 times.

JMSDF 4th Wing 3rd Squadron

