

1:35 Scale

Item No.:83805

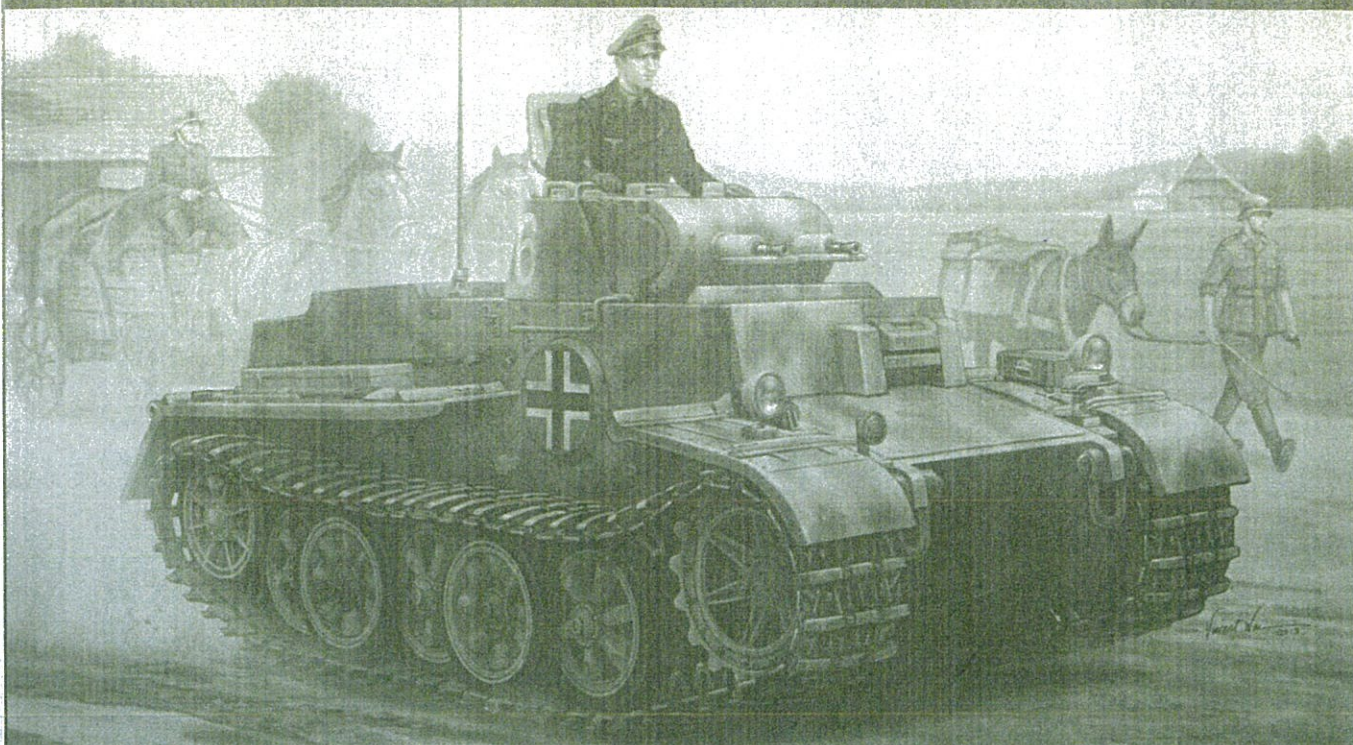

German Pzkwf. I Ausf. F (VK18.01)-Late

ドイツ I 号戦車 F 型 (VK18.01) 後期型

德国VK18.01轻型坦克后期型

PLEASE READ BEFORE OPERATION!

- * Tools recommended as below: (Not included)
Adhesives; Paints; Side Cutters; Sharp Edged Pliers; Modeling Knife; Modeling File; Nippers; Drill; Scissors; Sand Paper; Soft Cloth; Cyanoacrylate Glue.
- * Make sure to read this instruction listed below before assembling.
- * The kit contains the small parts, they can be dangerous if swallowed by mistake, so keep them away from reach of children.
- * Cut the all parts off carefully and remove the waste parts into the garbage can.
- * More caution and care should be needed for cutting and handling the photo etched parts.
- * Make attention that some parts should be attached the decal when assembled.
- * During assembling, please tear up and throw away the plastic bags, or may cause the dangerous if wearing over head by children's mistake.
- * When using the adhesives and paints, please do not use them in the closed room or near the fire, also must be very careful to protect your eyes, face and clothes.
- * Adult supervised when assembled by children under 14 years old.

装配前请仔细阅读:

- * 推荐使用的模型工具(请自备):
专用模型胶水, 专用模型油漆, 水口剪刀, 长咀钳, 刀片, 锉刀, 镊子钳, 钻, 剪刀, 软布, 砂纸, 瞬间快干胶等。
- * 用水口剪刀或刀片小心切下所有塑胶零件和蚀刻片零件, 不要遗失小零件。
- * 切取蚀刻片时应特别注意防止利边划伤手指。
- * 用模型锉刀小心锉平所有零件表面的注射浇口。
- * 用适量的强力快干胶水粘合蚀刻片零件和金属轴, 切忌过量, 否则可能导致可动零件被粘住。
- * 注意某些零件表面需在装配时同步贴上水贴纸。
- * 制作时应远离幼儿并将包装袋及时收妥, 谨防小孩玩耍而引起意外。



cyanoacrylate glue
强力胶



weight
配重



make hole
钻孔



cut / remove
切除



option
选择



no cement
不涂胶水



decal
贴纸



bend
弯曲



repair
填补

The method to apply the decals

1. Cut off the decal from the decal paper and put it into the warm water 40°C for 10 seconds.
2. Take the decal from the water and put it on a piece of clean cloth.
3. Remove the decal slowly from the paper to the targeted location by a wet finger.
4. Use a piece of dry and soft cloth to press it gently on the decal until it getting dry and no bubble existing.

水贴纸的使用方法:

- 一. 把相关的印花从水贴纸上剪下, 放入40°C左右的温水中浸10秒。
- 二. 然后将印花放在干净的布上。
- 三. 拿上印花纸板, 手指蘸水将印花移到适当的位置。
- 四. 用软干布轻压印花直至水干, 气泡消失。

部品图 Parts

AX2

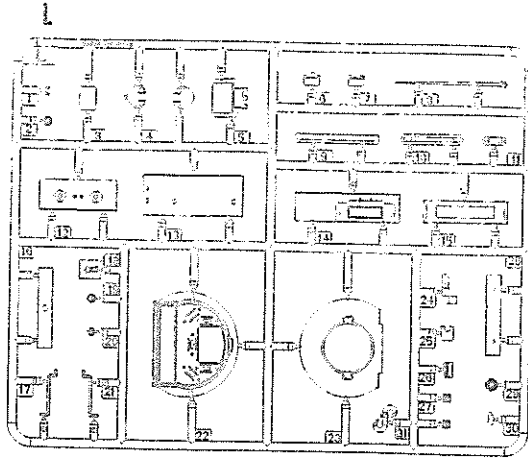
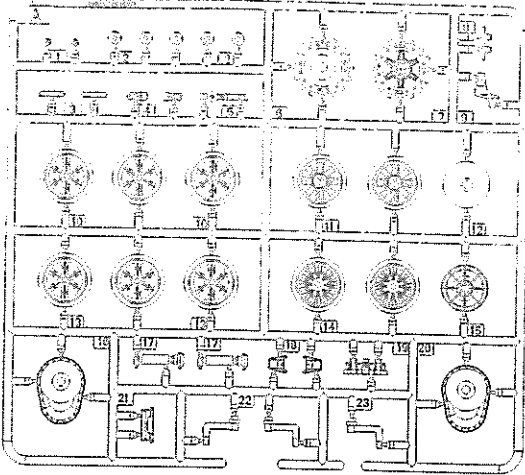

M

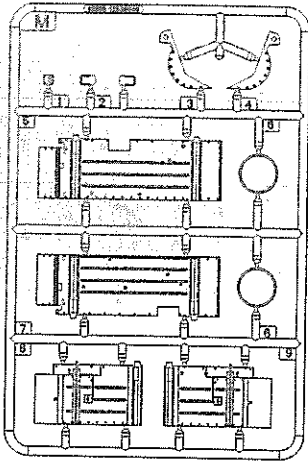

RX2

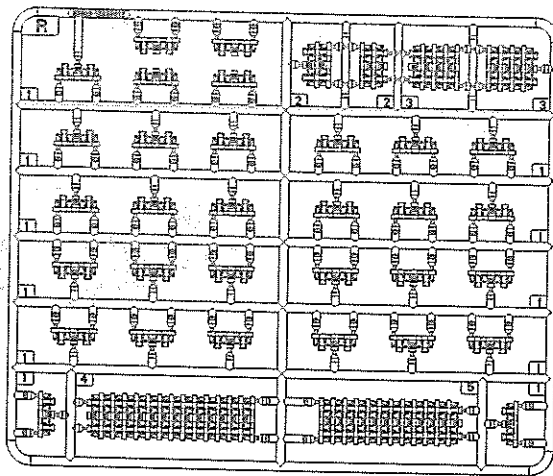

F

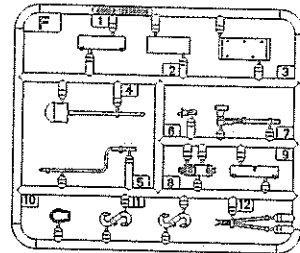

G

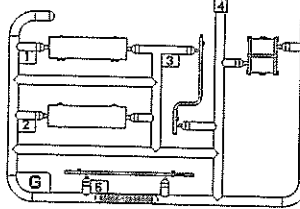

Kx2

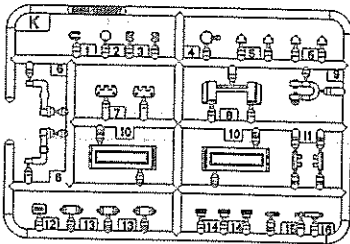

车底
Lower hull

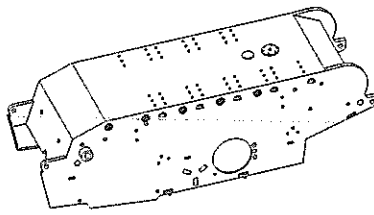

H

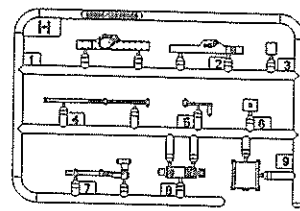

水贴
Decal

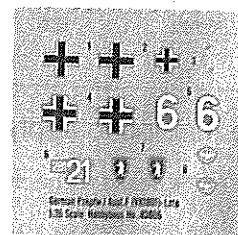

车面
Upper hull

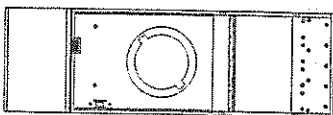

蚀刻片
PE

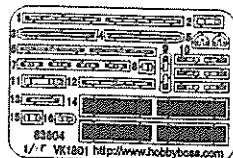

透明片
Transparent part

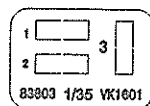

1
STEP

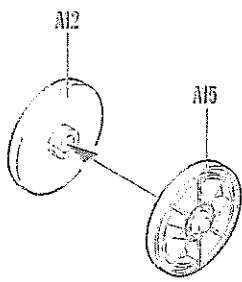

<<A>> 制作2组
Make two

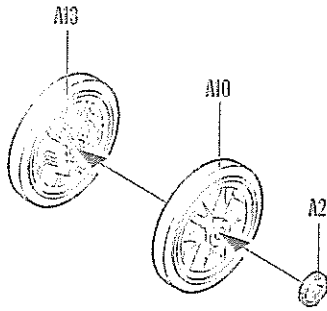

<> 制作6组
Make six

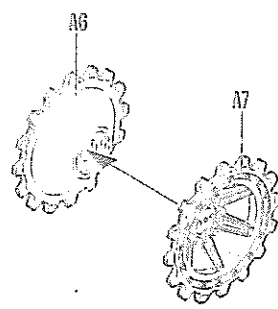

<<C>> 制作2组
Make two

2
STEP

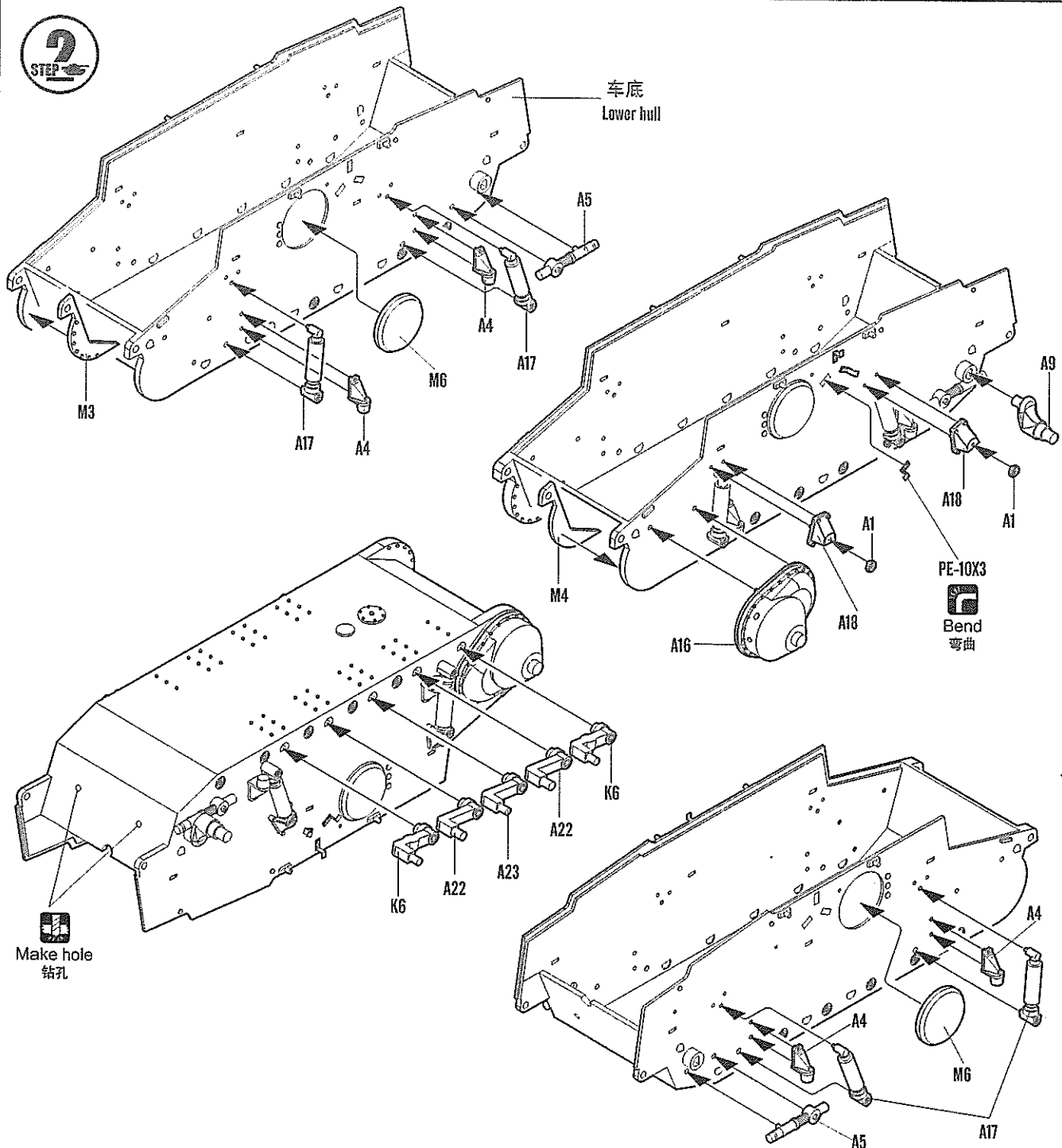

3
STEP

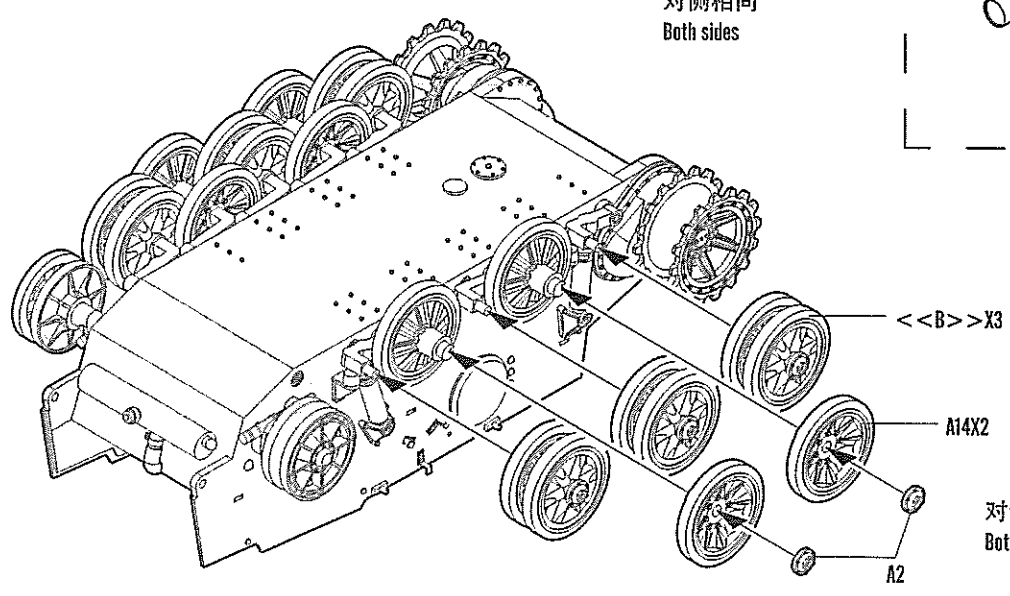
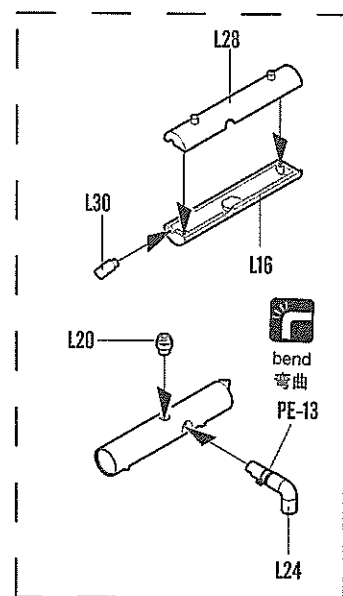
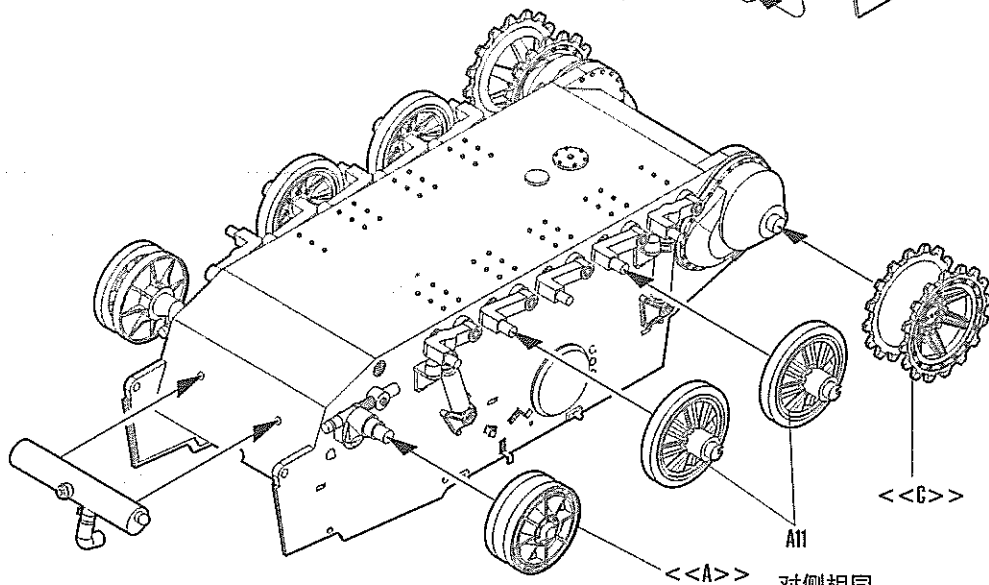
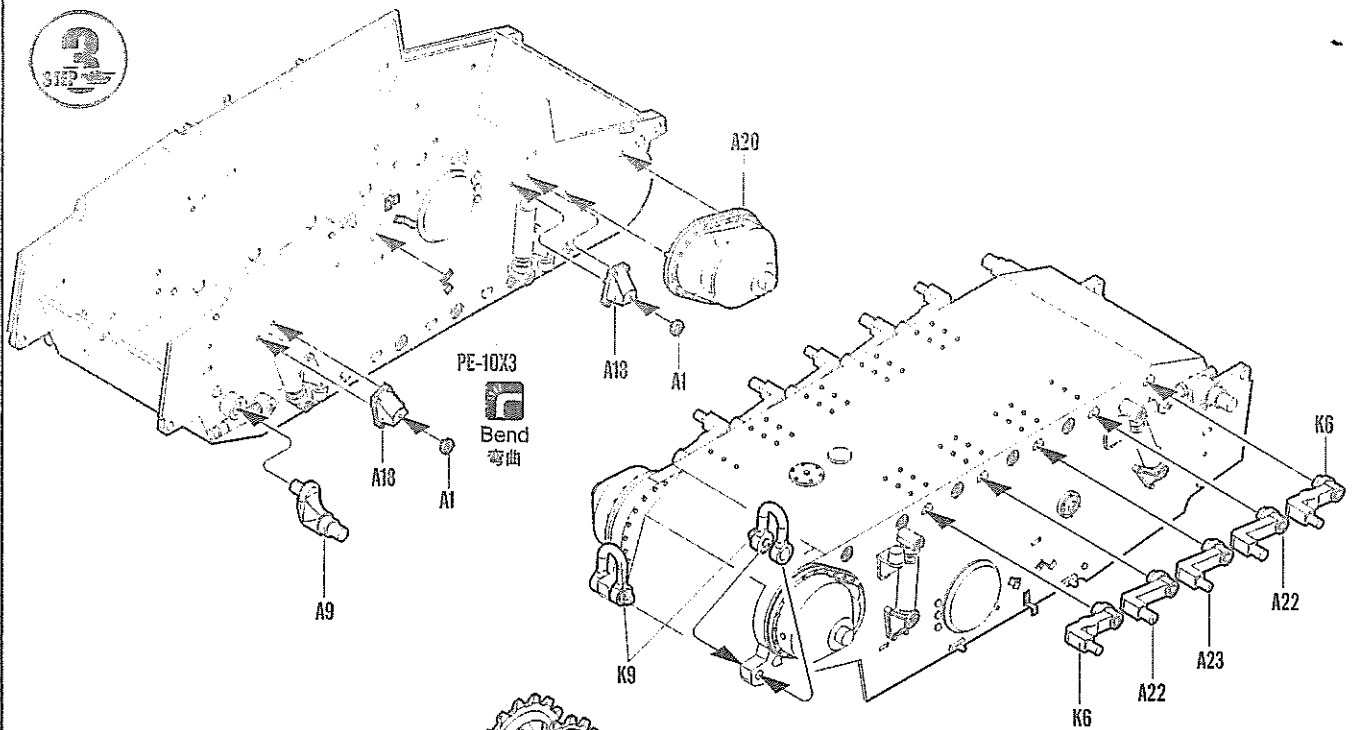

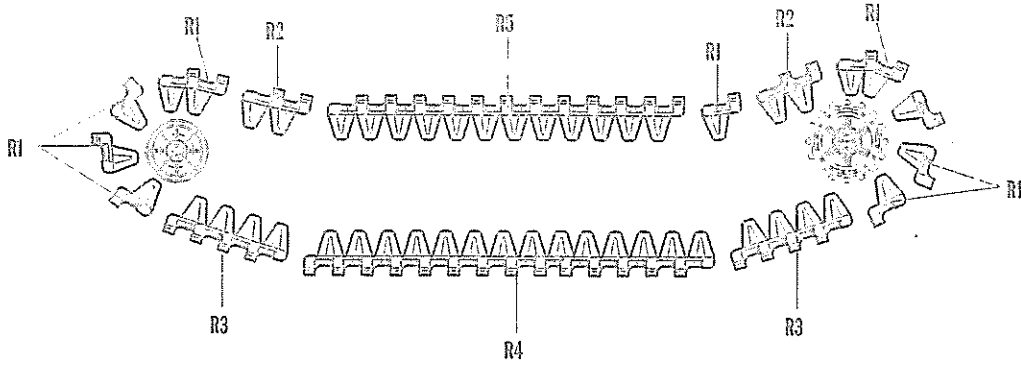

RFX29

制作2组
Make two

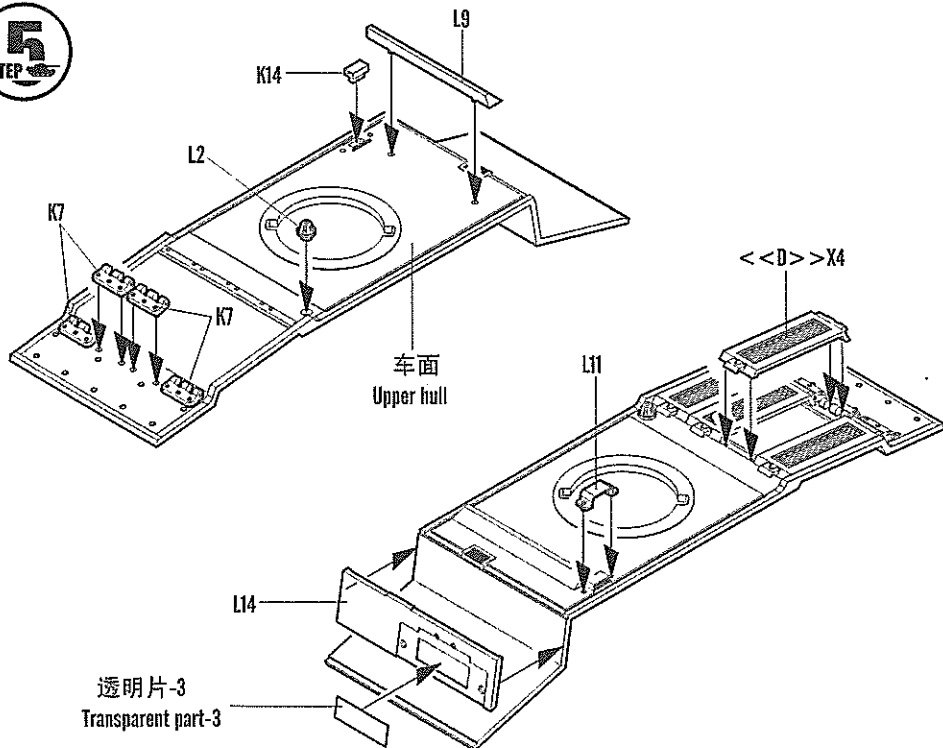
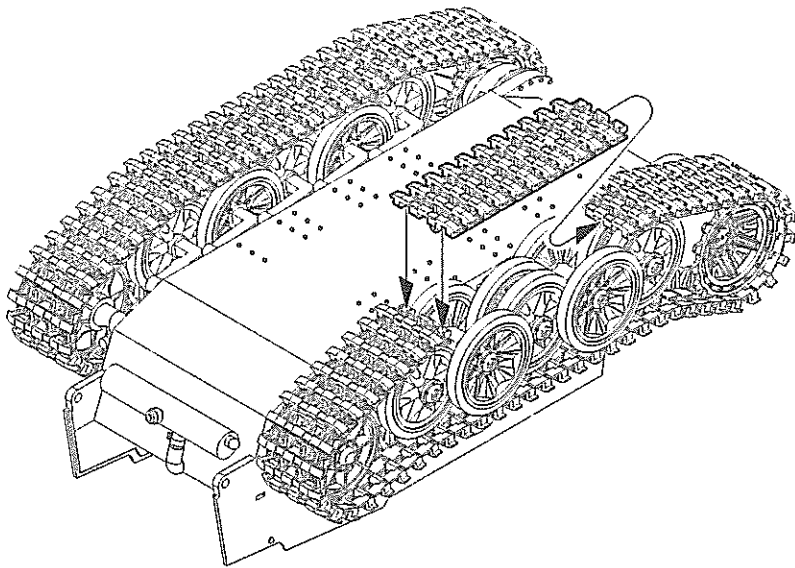

<<D>> 制作4组
Make four

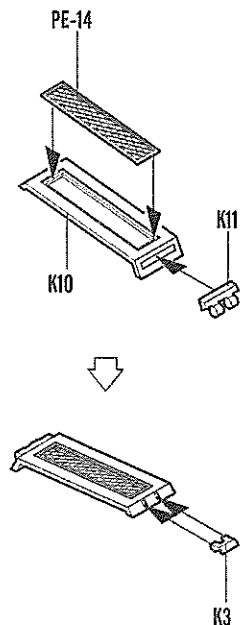

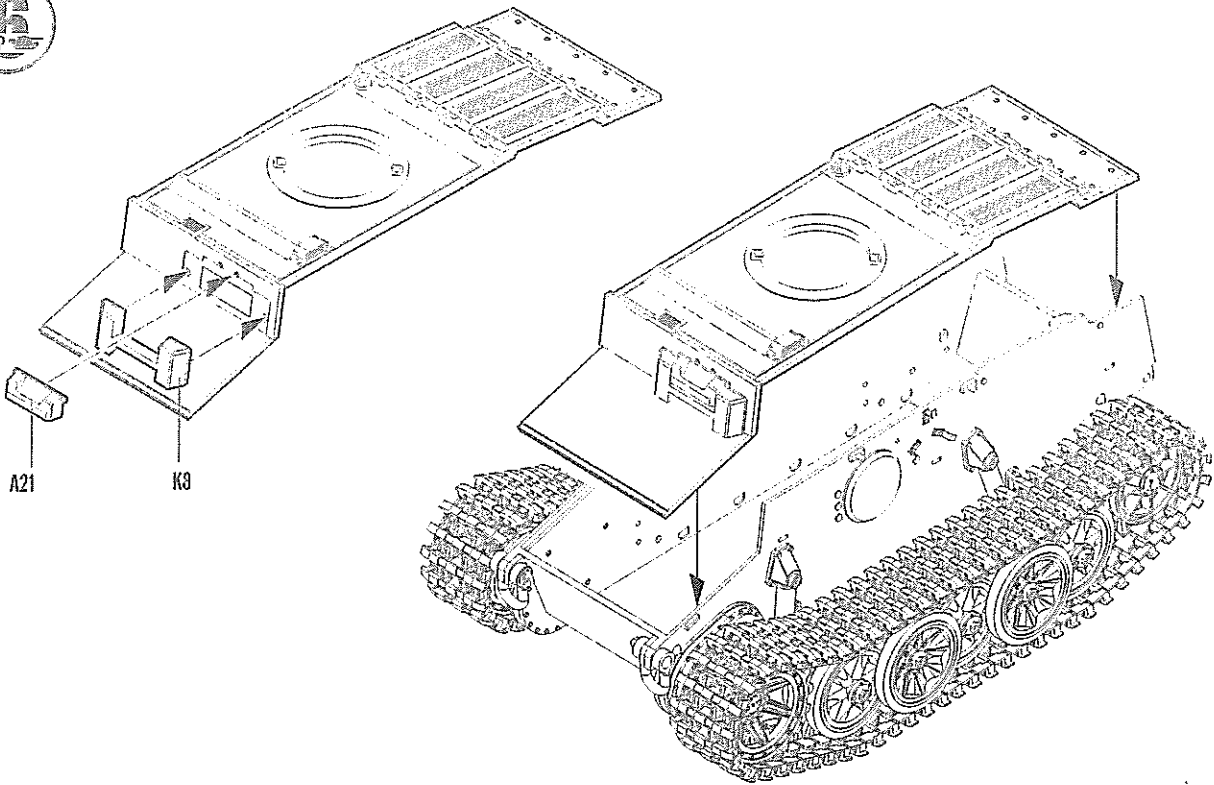

<<E>>

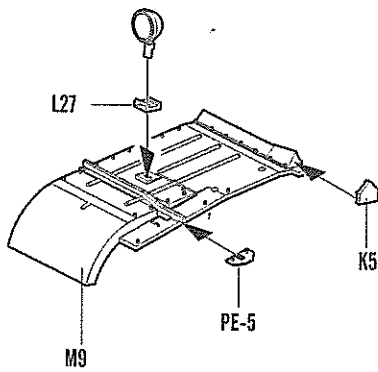

Bend
弯曲

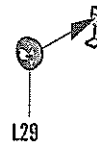
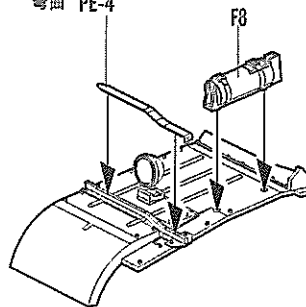

Bend
弯曲

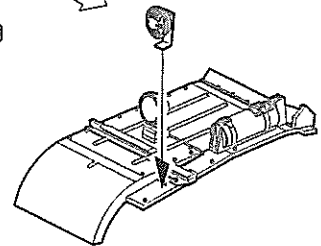

<<F>>

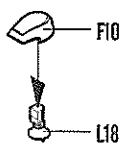
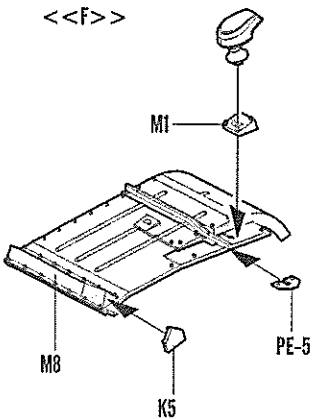

Bend
弯曲

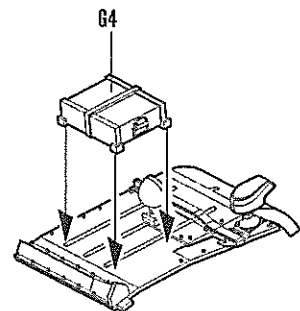
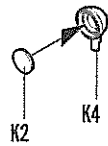
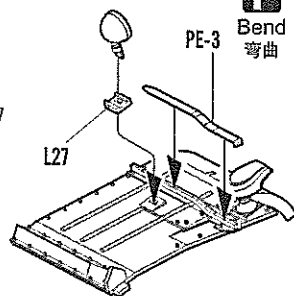

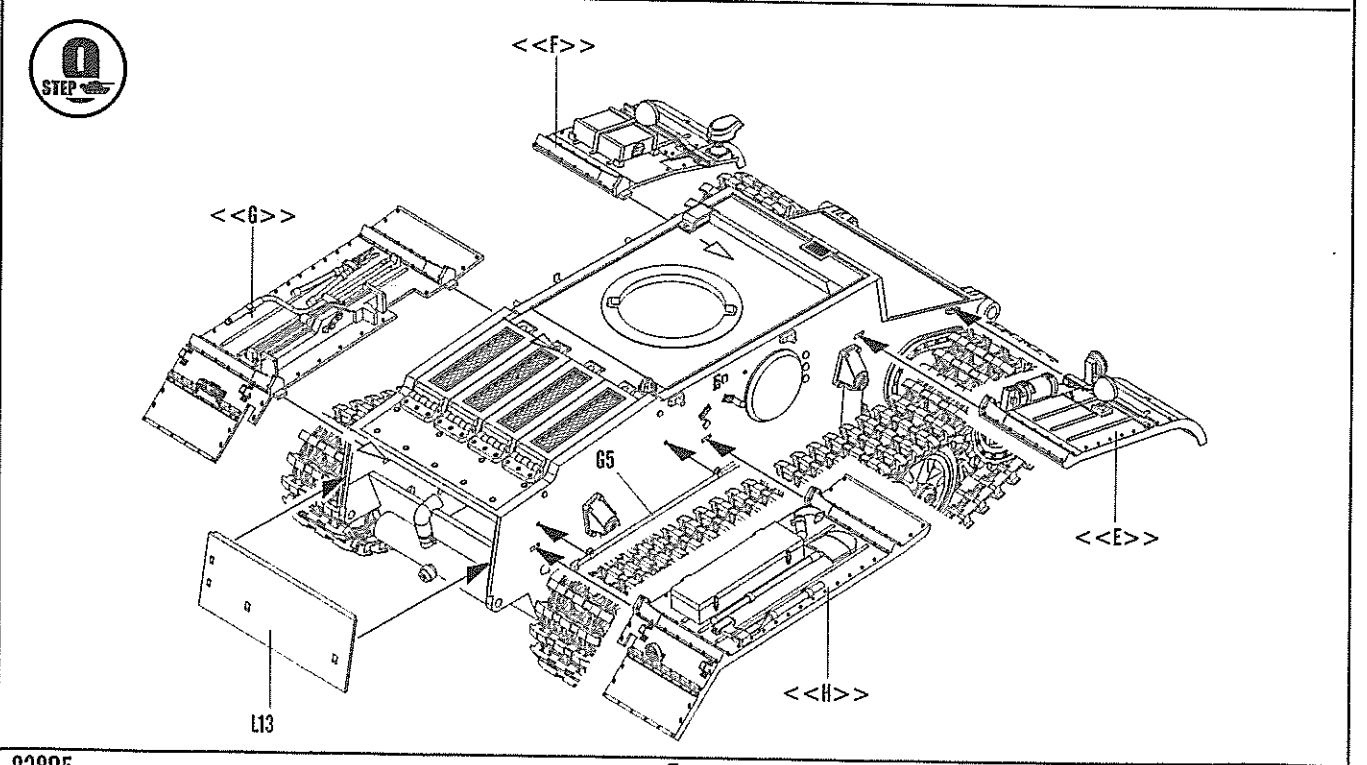
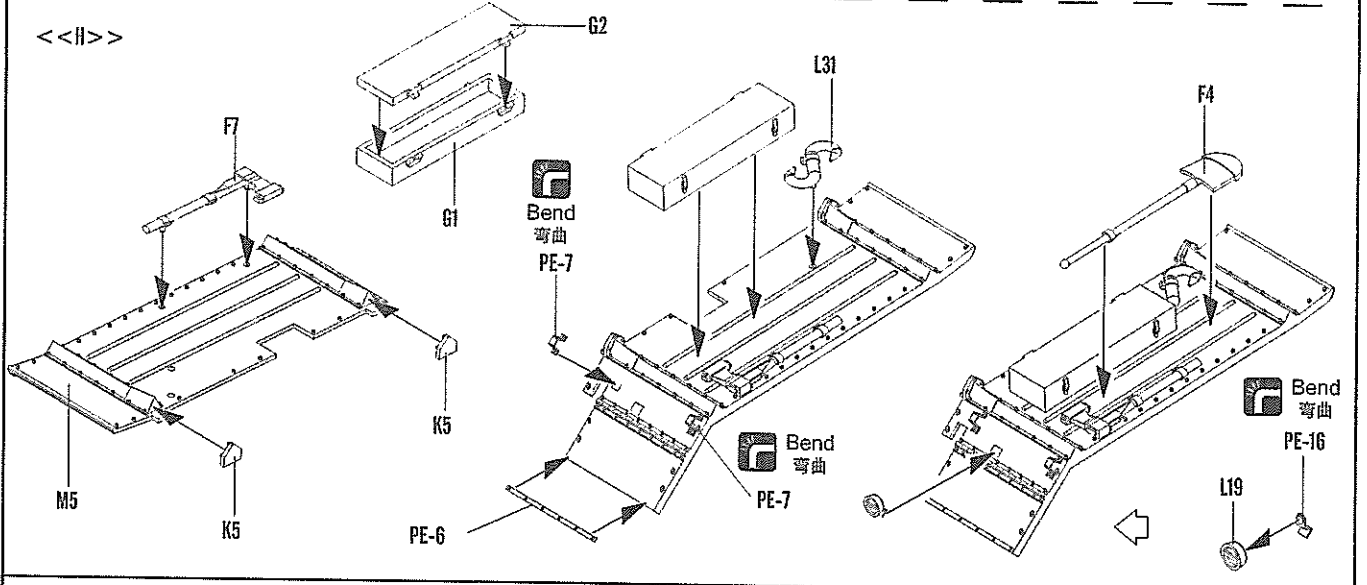
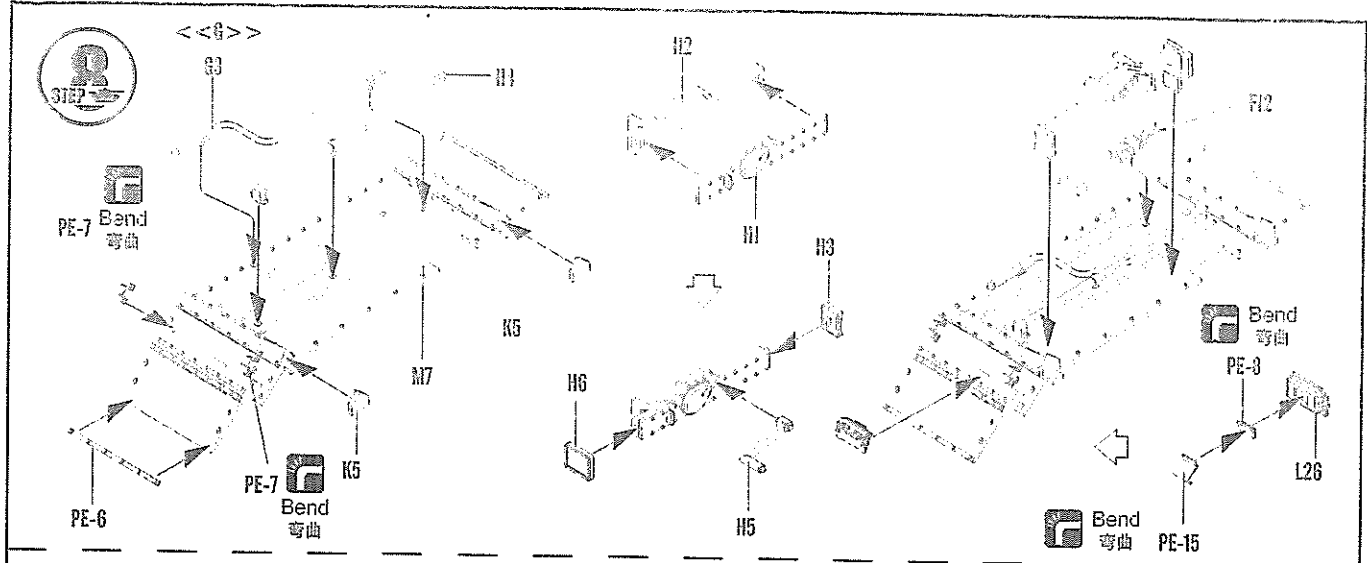

10
STEP

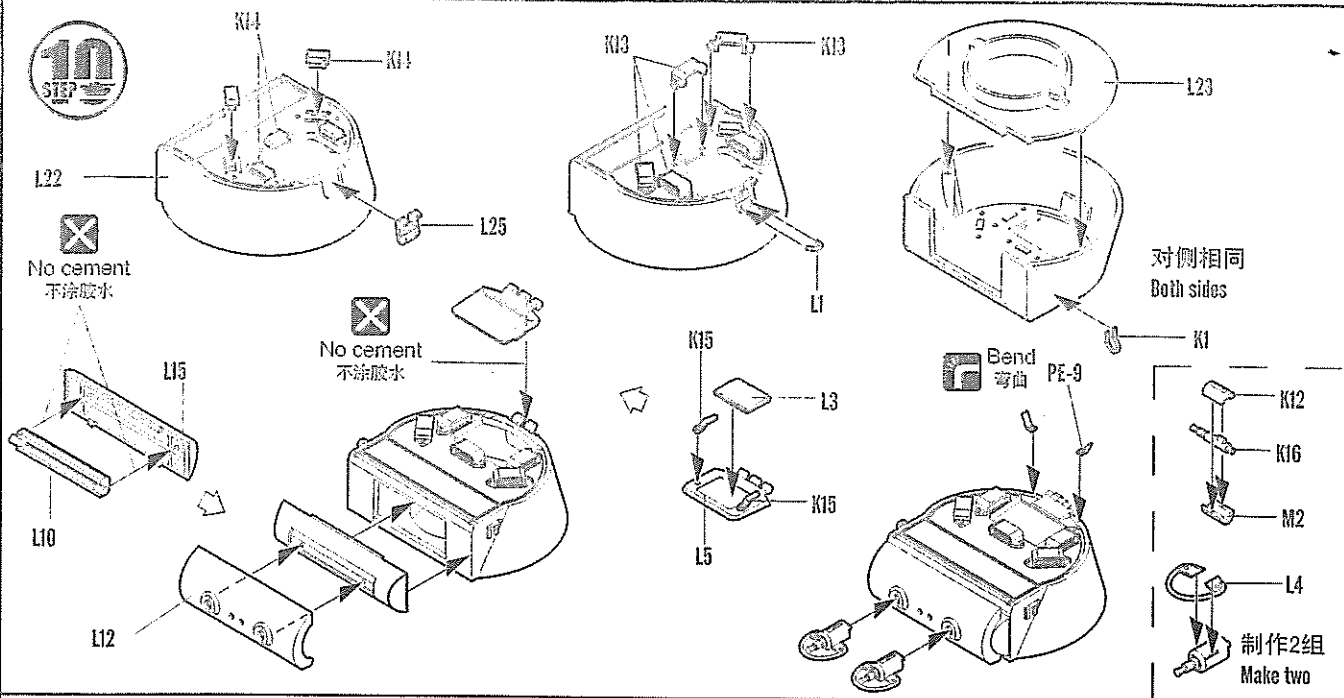

11
STEP

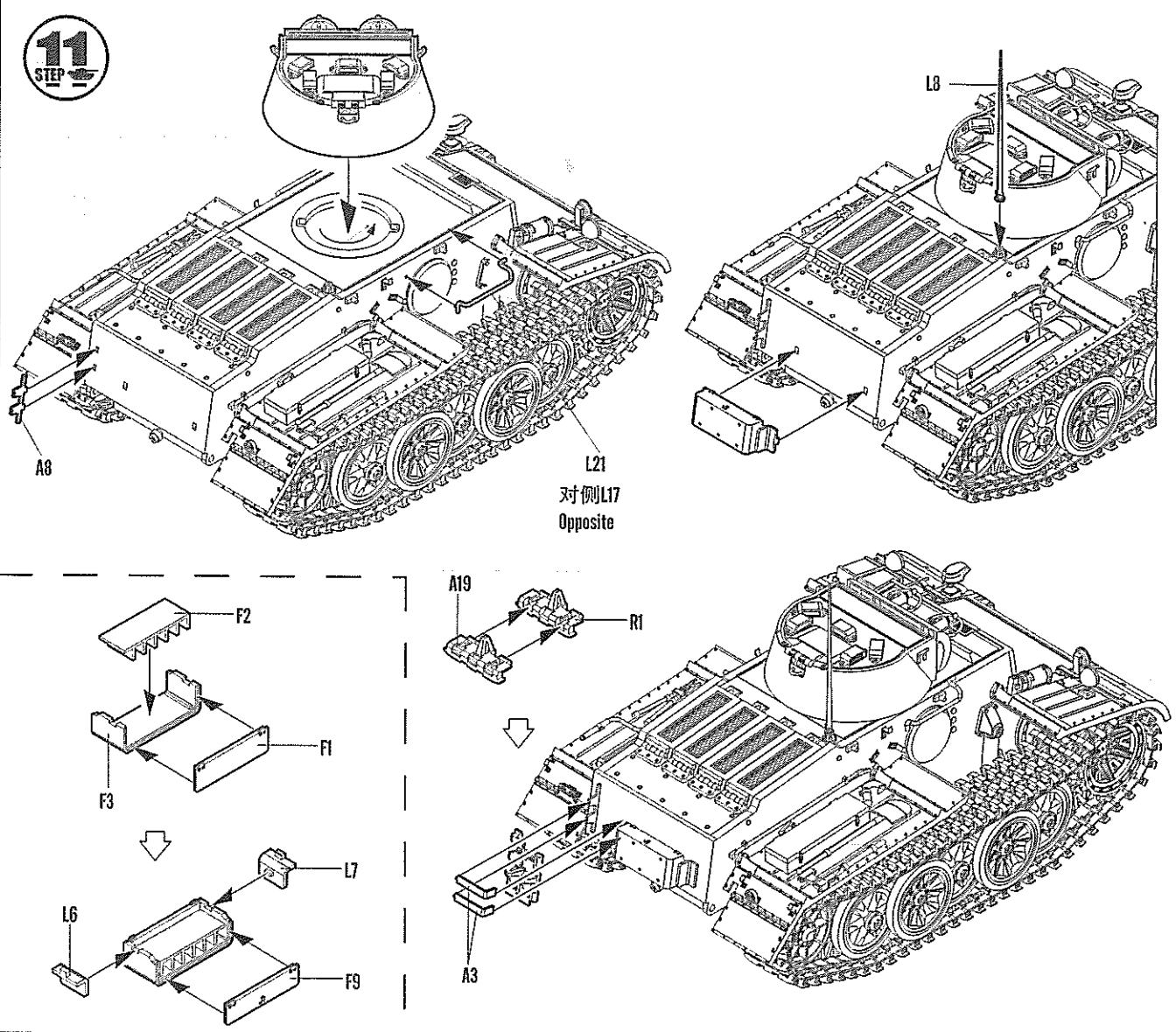

1:35
Scale 83805

German Pzkwf.w.I Ausf.F (VK18.01) -Late

HOBBY BOSS

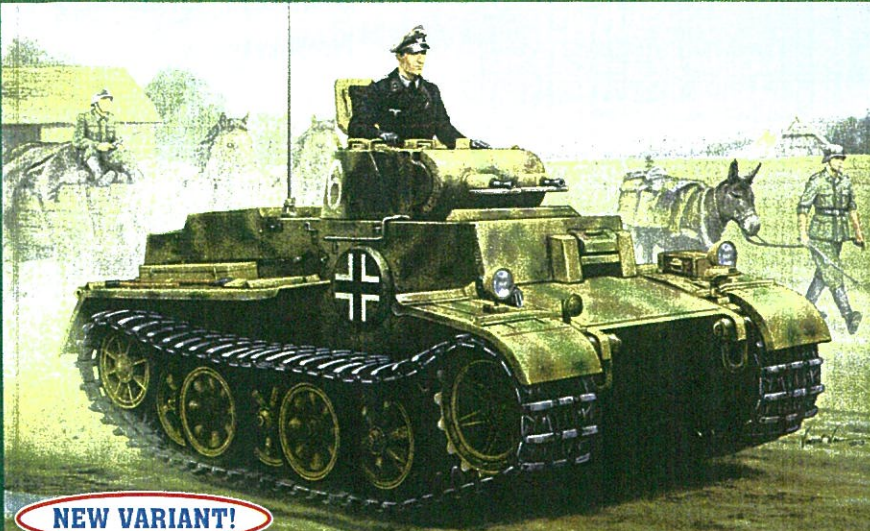

The second vehicle, the Ausf F, was as different from the Ausf C as it was from the Ausf A and B. Intended as an infantry support tank, the Panzer I Ausf F had a maximum armour thickness of 80 millimeters (3.15 in) and weighed between 18 and 21 tonnes. The Ausf F was armed with two 7.92-millimeter MG-34s. Thirty were produced in 1940, and a second order of 100 was later canceled. In order to compensate for the increased weight, a new 150 horsepower (110 kW) Maybach HL45 Otto engine was used, allowing a maximum road speed of 25 kilometers per hour (15.5 mph). Eight of the thirty tanks produced were sent to the 1 Panzer Division in 1943 and saw combat at the Battle of Kursk. The rest were given to several army schools for training and evaluation purposes.

Kit consists of over 270 parts on 12 sprues including hull and 29 parts photo-etched upgrade parts.

Dimension of completed model: Length:125mm Width:75.6 mm



PE parts are included in the kit.

NEW VARIANT!

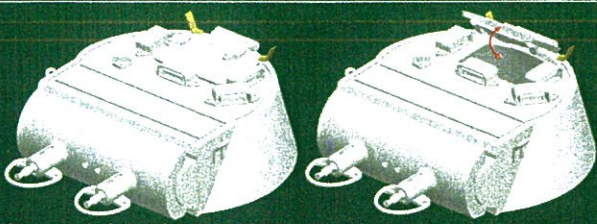

Commander's hatch can be open or closed.

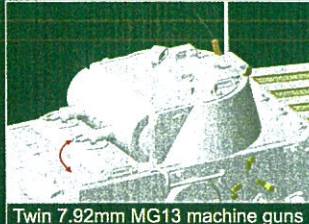

Twin 7.92mm MG13 machine guns elevate.

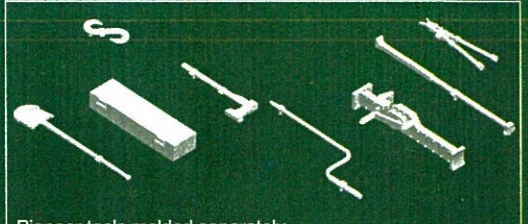

Pioneer tools molded separately.

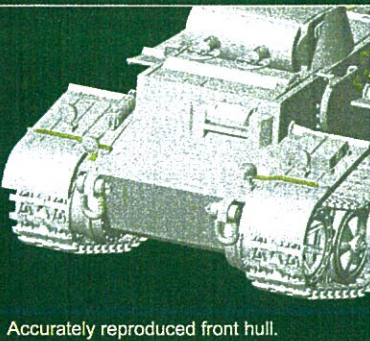

Accurately reproduced front hull.

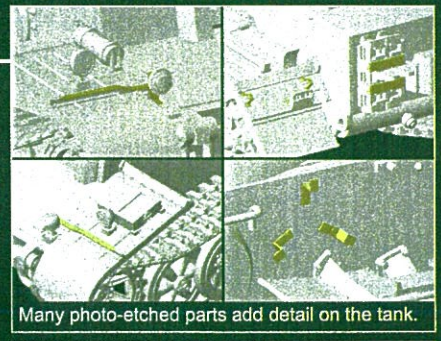
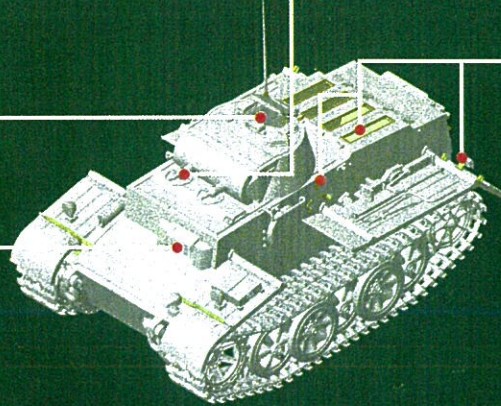

Many photo-etched parts add detail on the tank.

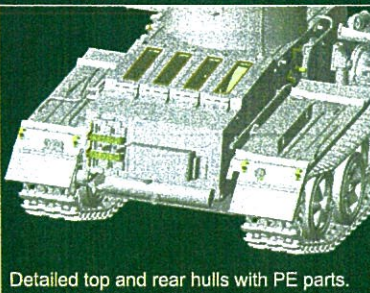

Detailed top and rear hulls with PE parts.

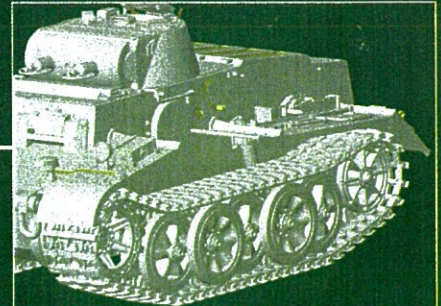
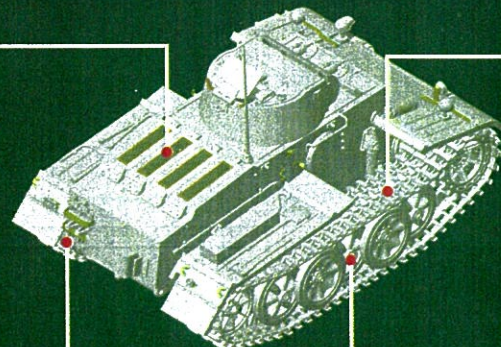

The intricate running gear is perfectly reproduced.

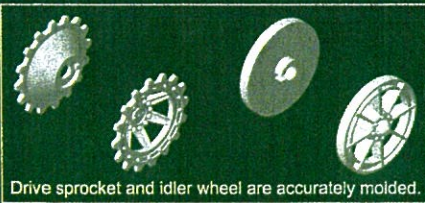

Drive sprocket and idler wheel are accurately molded.

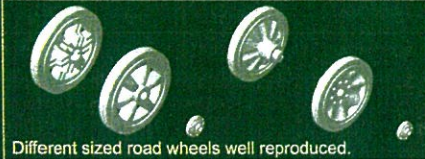

Different sized road wheels well reproduced.

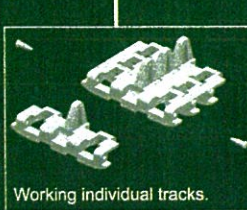

Working individual tracks.

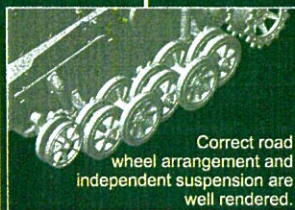

Correct road wheel arrangement and independent suspension are well rendered.

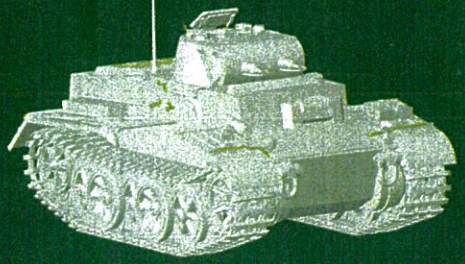

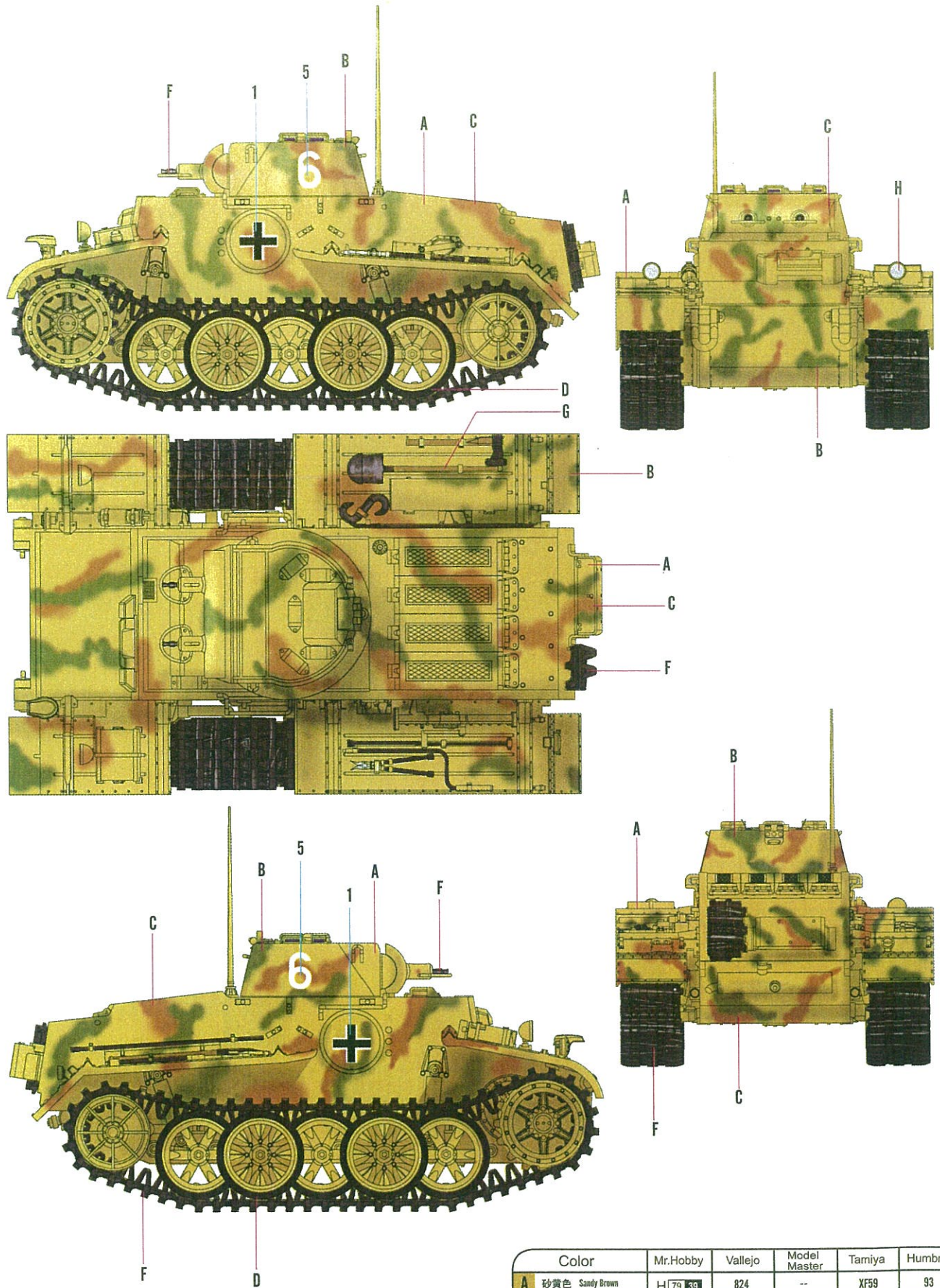

Color	Mr.Hobby	Vallejo	Model Master	Tamiya	Humbrol
A 砂黄色 Sandy Brown	H 79 39	824	--	XF59	93
B 暗绿色 Dark Green	H 70	--	--	--	--
C 红棕色 Red Brown	H 47 41	984	--	XF64	160
D 胎黑色 Tyre Black	H 77 137	--	--	--	--

NO..83805

*Some paints may not be available in your country. Please check your local hobby shop for substitute

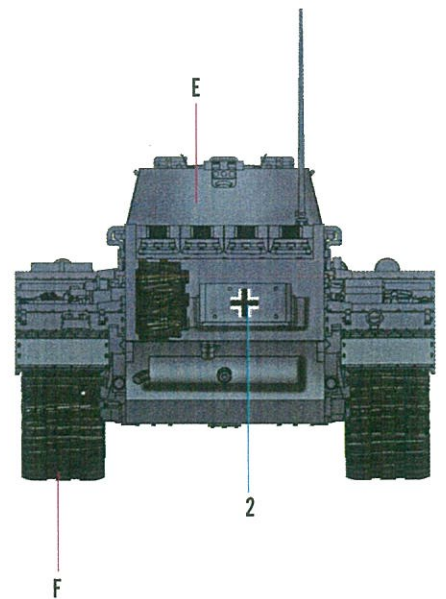
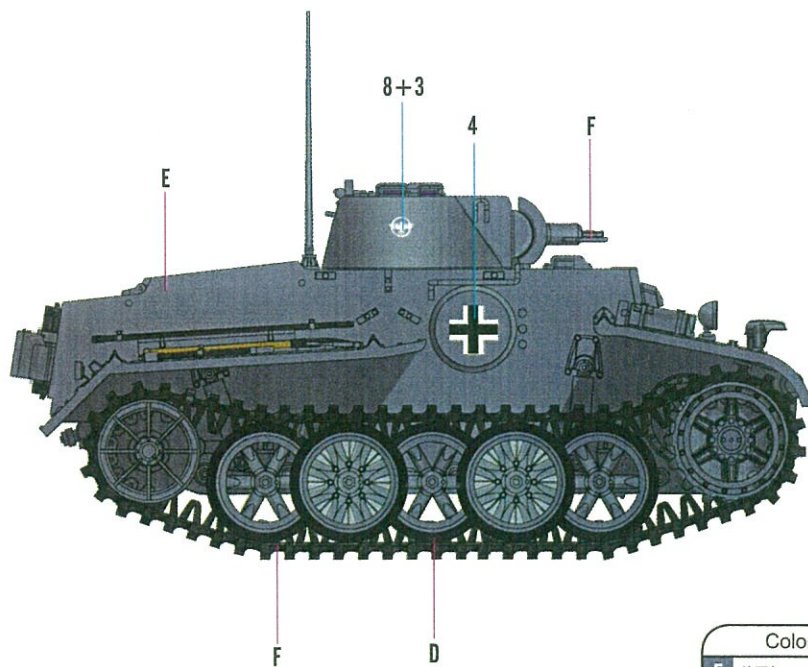
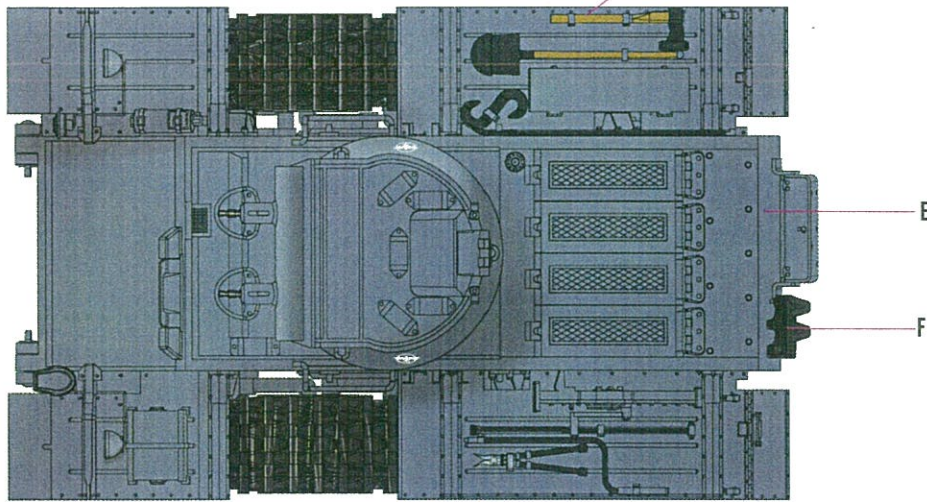
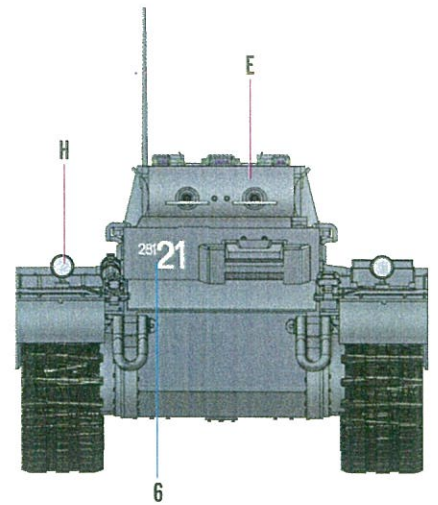
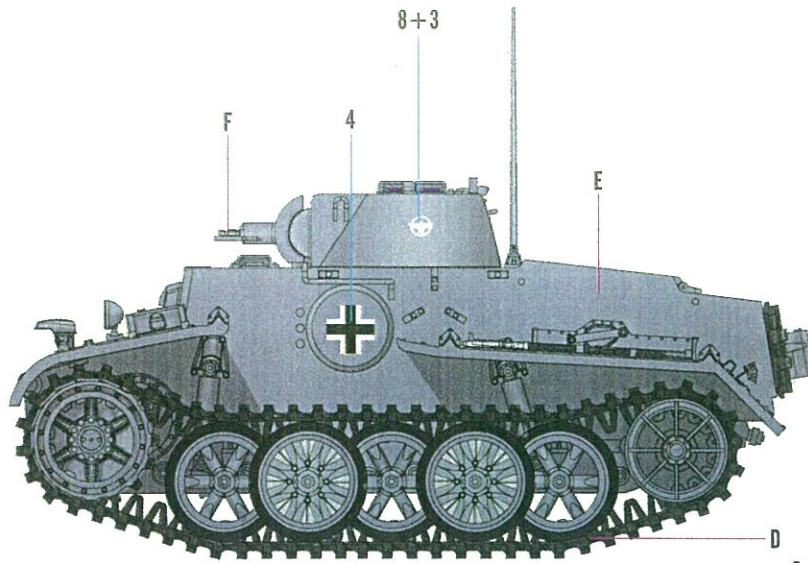

	Color	Mr.Hobby	Vallejo	Model Master	Tamiya	Humbrol
E	德国灰 German Gray	H 32 40	830	--	XF22	111
F	黑铁色 Steel	H 18 28	864	1402	--	--
G	木棕色 Wood Brown	H 37 43	983	1701	--	186
H	银色 Silver	H 8 8	997	1546	XF11	11

NO..83805

*Some paints may not be available in your country. Please check your local hobby shop for substitute