

M3A1

1:35 '39-'45 SERIES

Half-Track

3 in 1

Smart Kit

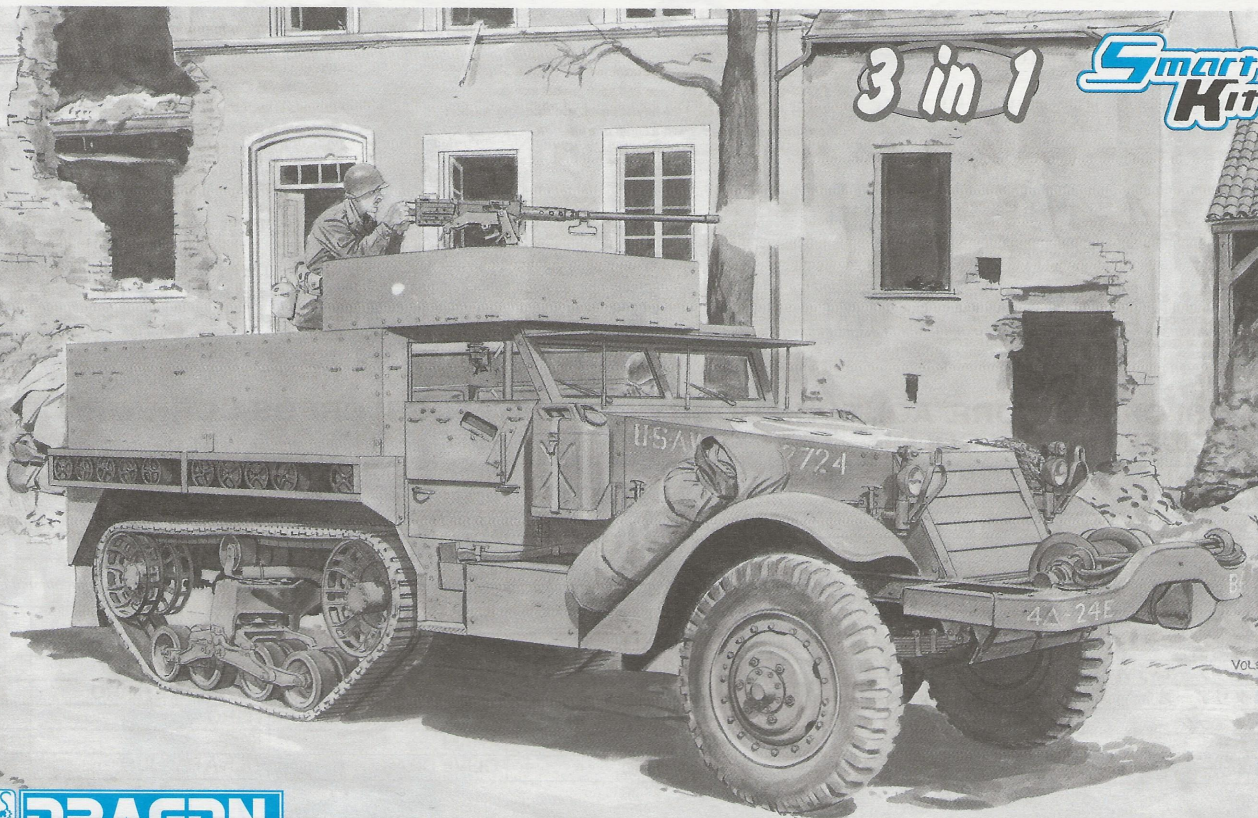

Project supervised by HIROHISA TAKADA. Technical drawings provided by H3 DESIGN OFFICE.

KIT NO.6332

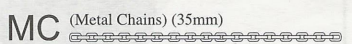
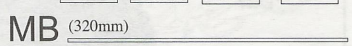
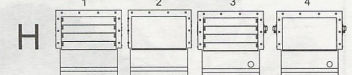
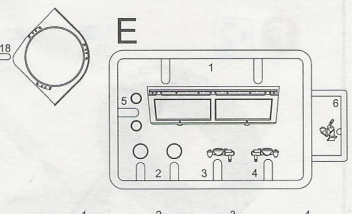
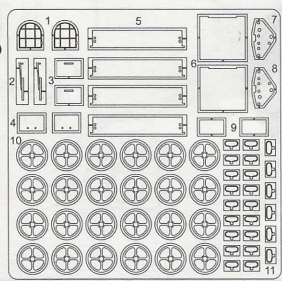
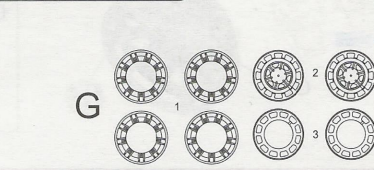
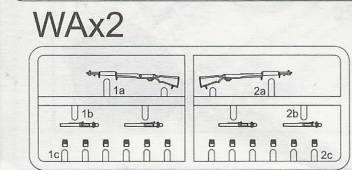
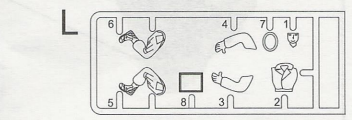
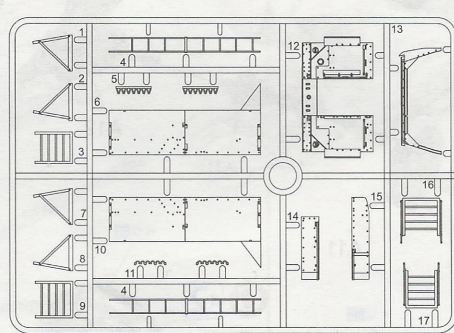
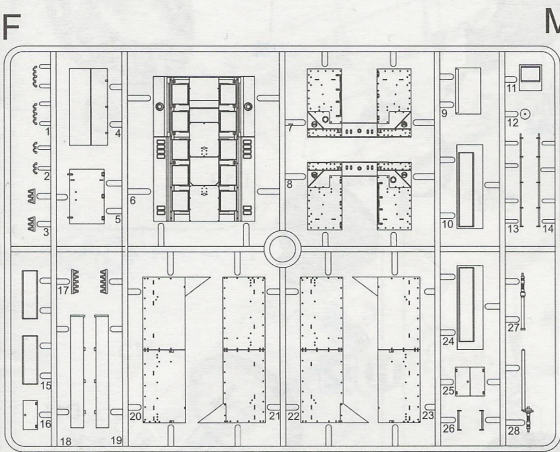
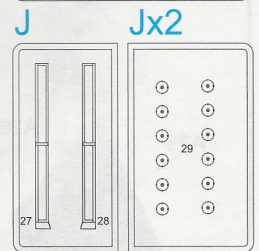
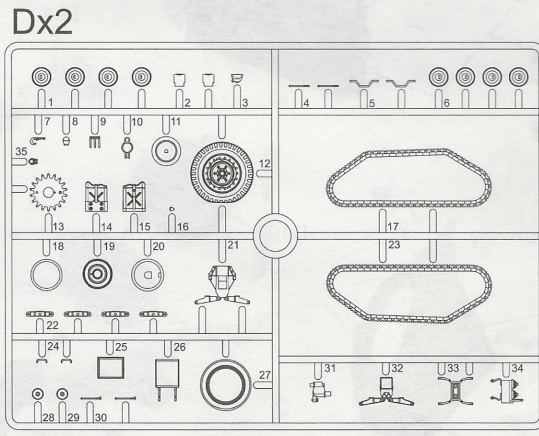
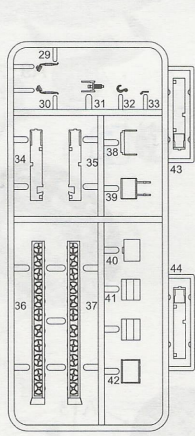
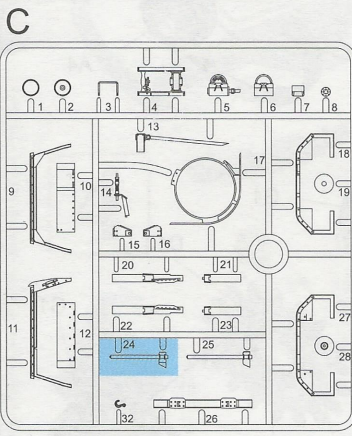
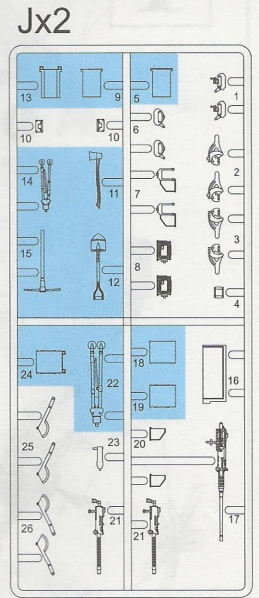
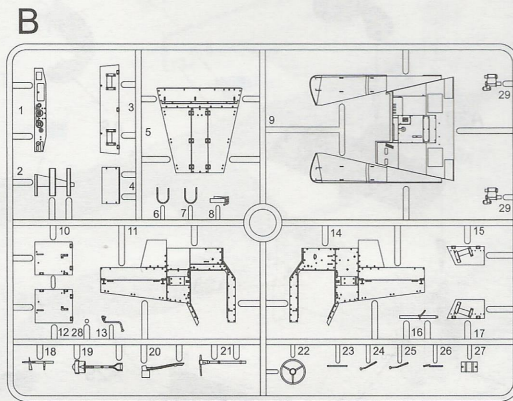
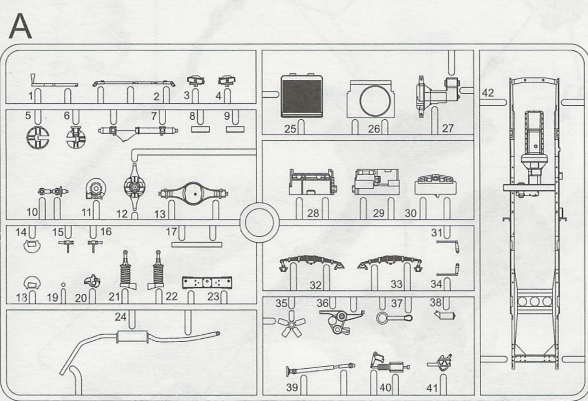

この部品は使用しません
Parts not for use.
Telle werden nicht verwendet.
Pieces a ne pas utiliser.
Parti nin utilizzati.
不需要使用的部件

組立ての注意

- ・接着剤や塗料は火の近くで使用しないでください。使用する際は窓を開けて換気をお願いします。
- ・塗料指定の1は GSI CREOS CORP. MR カラーの番号です。接着剤や塗料は含まれておりませんので、別にお買い求めください。
- ・部品をランナーから切り離す時は模型用ハサミ等を使用し、余分な部分はカッターやヤスリ等で仕上げてください。
- ・組立図のサインマークは下記をご覧ください。

《注意》

- ・勿ち近火處使用膠水或油漆，並打開窗戶保持空氣流通。
- ・1 代表 GSI CREOS CORP. 出品 MR.COLOR 的顏色編號。不包括膠水及油漆。
- ・自膠架中取出部件時，應用模型專用剪，並用界刀或小鉗除去多餘的膠料。
- ・各圖型的含意可參考本欄以下的說明。

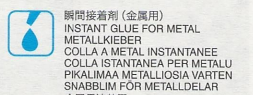
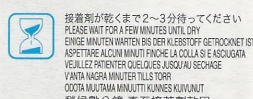
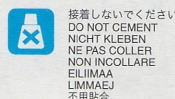
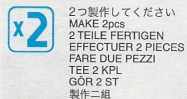

ZUR BEACHTUNG

- ・Kleber und Farbe nicht in der Nähe einer offenen Feuer verwenden und das Fenster von Zeit zu Zeit zur Belüftung öffnen.
- ・Symbole wie 1 beziehen sich auf die Farbnummern GSI CREOS CORP. MR. COLOR. Kleber und Farbe sind nicht enthalten.
- ・Zum Abschneiden der Teile vom Verbundstück eine Modellierschere verwenden und die überstehenden Plastikteile mit einem Messer oder eine Feile beseitigen.
- ・Die Bedeutung der Symbole finden Sie unten in dieser Spalte.

CAUTION

- ・When you use glue or paint, do not use near a naked flame, and use in a well-ventilated room.
- ・Symbols such as 1 refer to the color number of GSI CREOS CORPS. MR. COLOR. Glue and paint are not included.
- ・When you take parts off the runner frame, use modeling scissors and trim excess plastic with a cutter or a file.
- ・See below for the meaning of symbols.

ATTENTION

- ・Ne pas utiliser de colle ou de peinture a proximite d'une flamme nue, et aérer la pièce de temps en temps.
- ・Le numéro 1 pour l'indication de couleurs correspond au numéro de GSI CREOS CORP. MR. COLOR. La colle et la peinture ne sont pas comprises.
- ・Pour retirer les pièces hors du cadre, utiliser des ciseaux spéciaux pour maquette le plastique en excès avec un cutter ou une lime.
- ・Voir la fin de cette colonne pour la signification des symboles

ATTENZIONE

- ・Non usare colla e vernice vicino a fiamme esposte. e aprire le finestre di tanto in tanto per cambiare l'aria.
- ・1 delle indicazioni di colore si riferisce al numero di colore di GSI CREOS CORP. MR. COLOR. Colla e vernice non sono incluse.
- ・Quando si staccano parti del carrello, usare forbici da modellismo e eliminare la plastica in eccesso con un coltello o una lima.
- ・Vedere in fondo a questa colonna per il significato dei simboli.

H1 GSI CREOS CORP. AQUEOUS HOBBY COLOR 1 GSI CREOS CORP. MR. COLOUR MODEL MASTER COLOR

H1 2	ブラック	1747	BLACK	SCHWARZ	NOIR	NERO	黑色
H1 3	レッド	1503	RED	ROT	ROUGH	ROSSO	紅色
H1 8	シルバー	1546	SILVER	SILBER	ARGENT	ARGENTO	銀色
H1 12	つや消しブラック	1749	FLAT BLACK	MATTSCHWARZ	NOIR MAT	NERO OPACO	啞黑色
H1 16	黒鐵色	1415	STEEL	STAHL	ACIER	ACCIAIO	黒鐵色
H1 37	ウッドブラウン	1735	WOOD BROWN	HOLZBARAUN	BRUN BOIS	MARRONE LEGNO	木棕色
H1 44	はだ色	1516	FLESH	FLEISCHFARBE	CHAIR	COLOR CARNE	肌肉色
H1 76	焼鐵色	1406	BURNT IRON	GEBR, EISEN	FER BRULE	FERRO BRUCIATO	燒鐵色
H1 90	クリアーレッド	1503	CLEAR RED	ROT, REIN	ROUGE CLAIR	ROSSO CHIARO	透明紅
H1 92	クリアーオレンジ	1527	CLEAR ORANGE	ORANGE, REIN	ORANGE CLAIR	ARANCIO CHIARO	透明橙
H1 99	ブラック	1747	BLACK	SCHWARZ	NOIR	NERO	黑色
H1 60	カーキ	1782	KHAKI	KHAKI	KHAKI	KAKI	柿褐色
H1 90	オリブトラブ FS 34087	1711	OLIVE DRAB	OLIVE DRAB	OLIVE DRAB	OLIVA PALLIDO	橄欖綠色

1

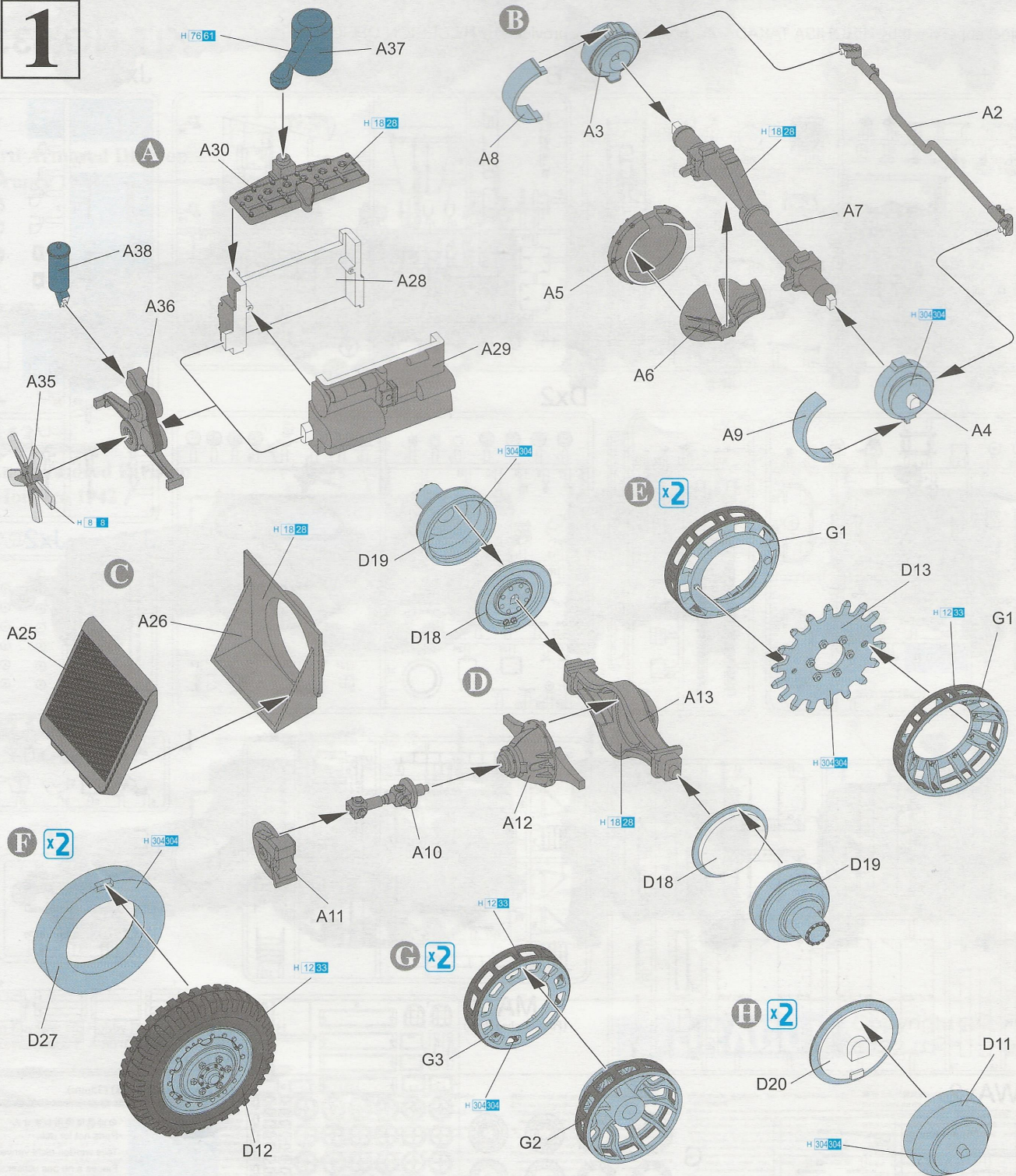

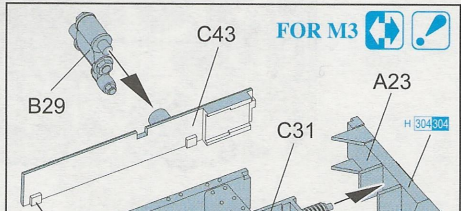
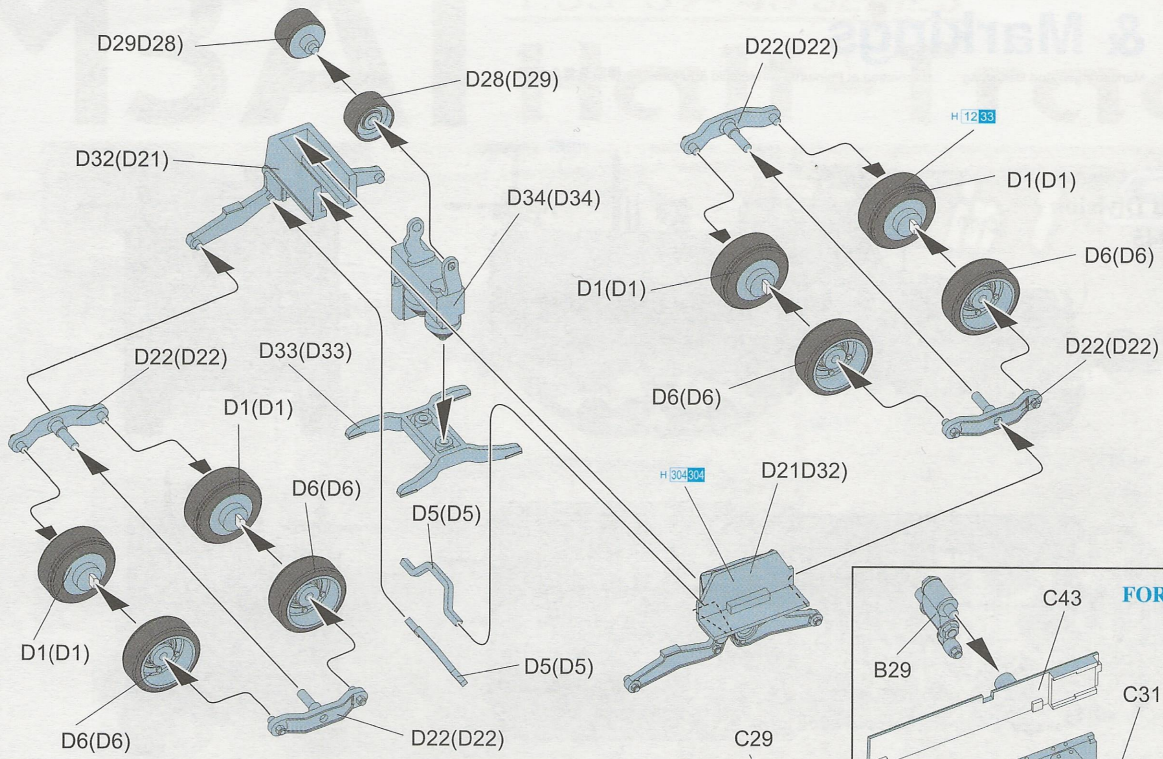

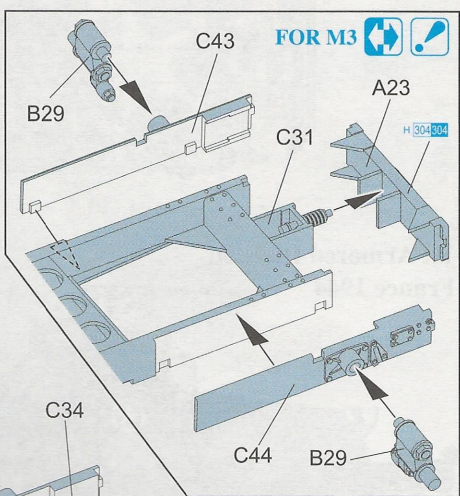
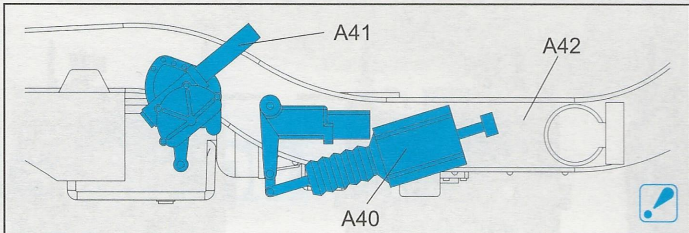
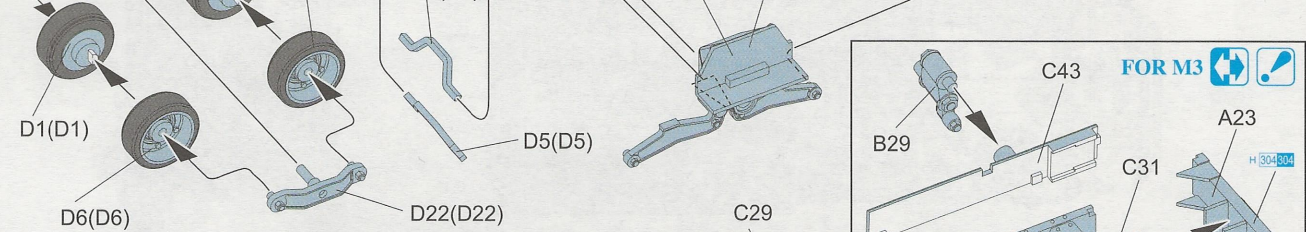

3

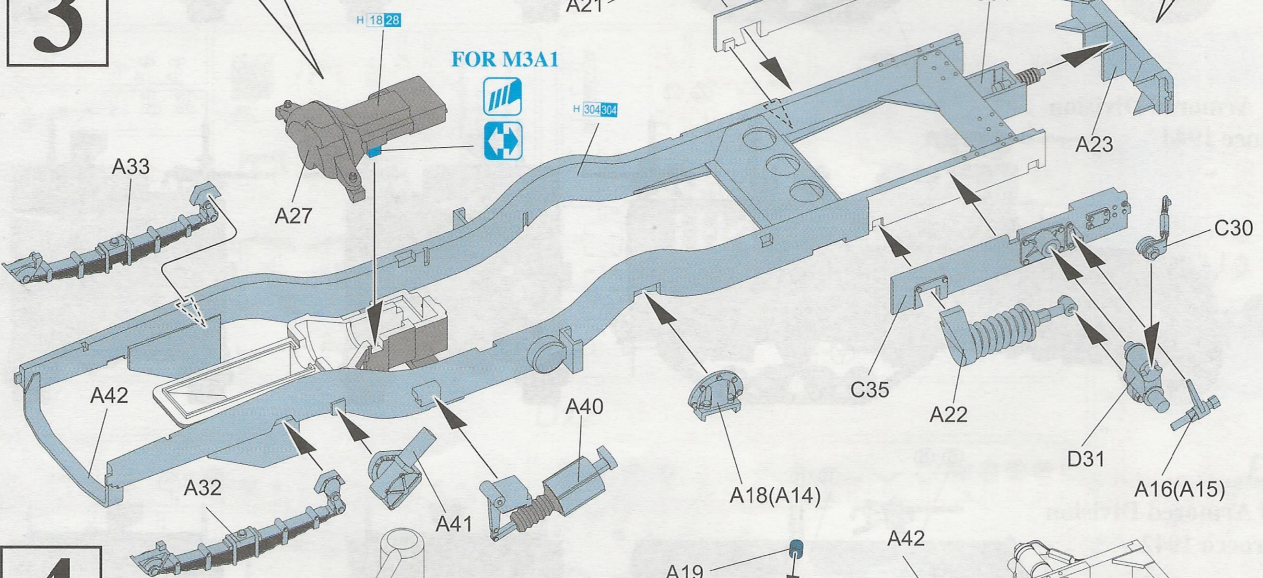

4

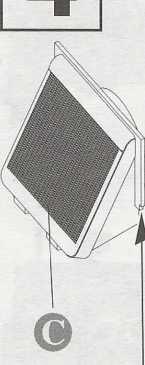
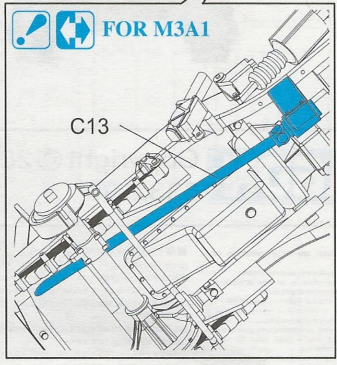
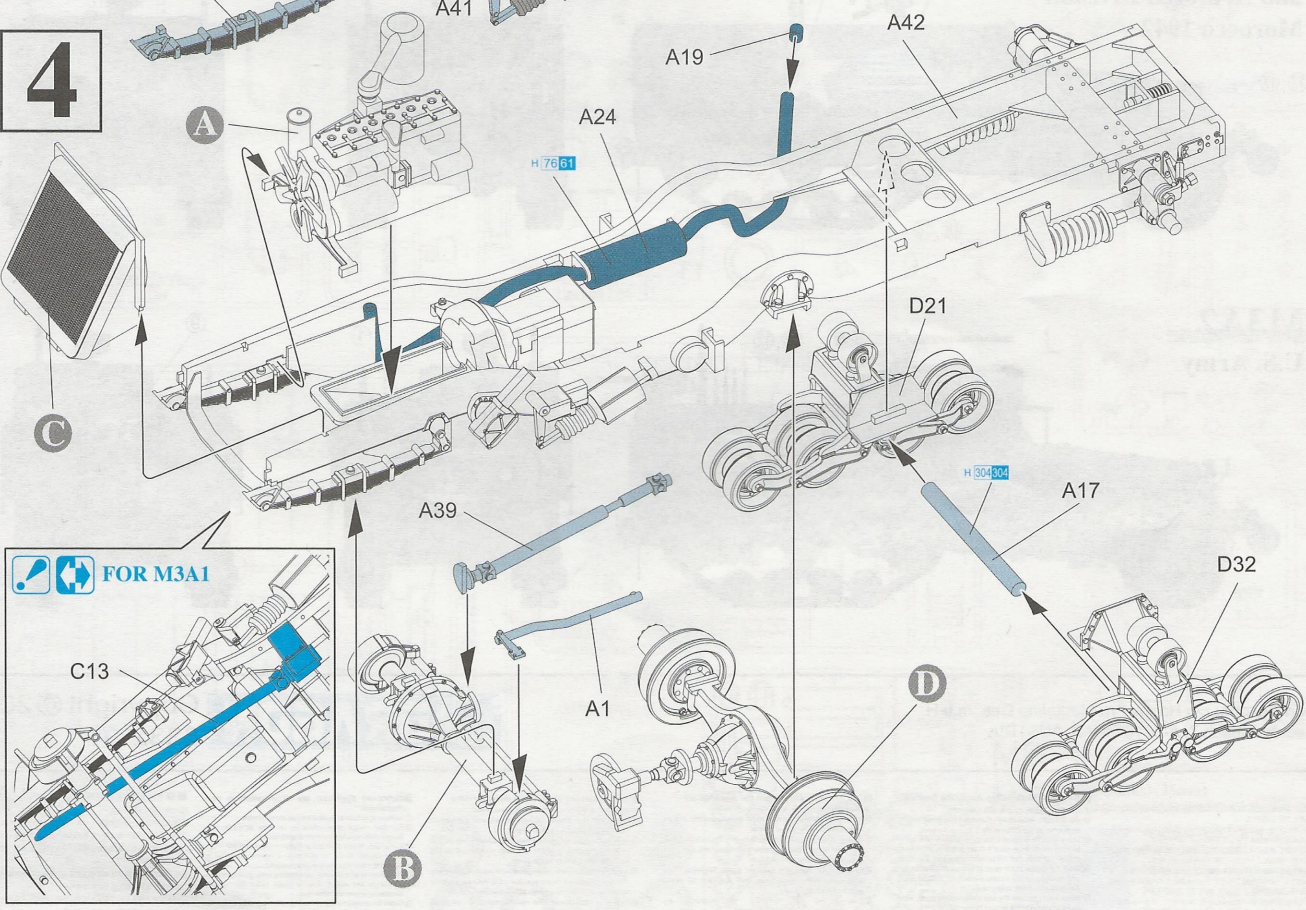

A

B

D

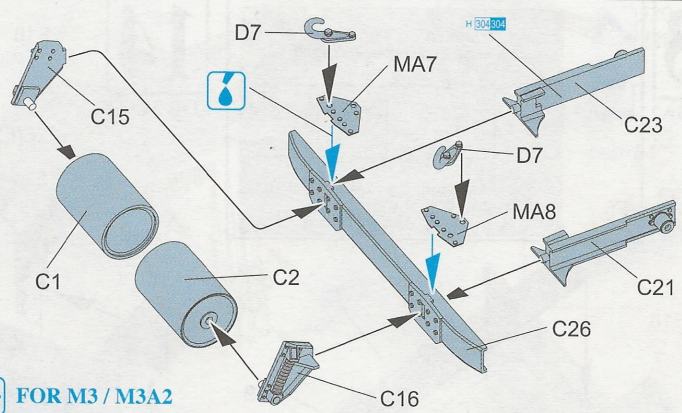
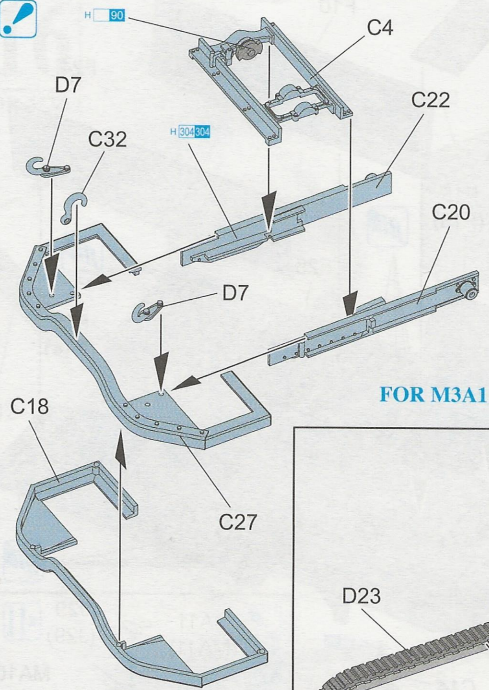

FOR M3A1  FOR M3 / M3A2

A31

5

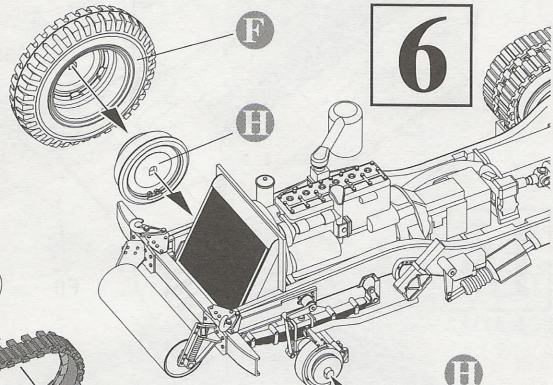
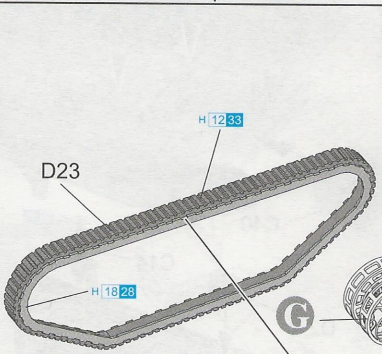

6

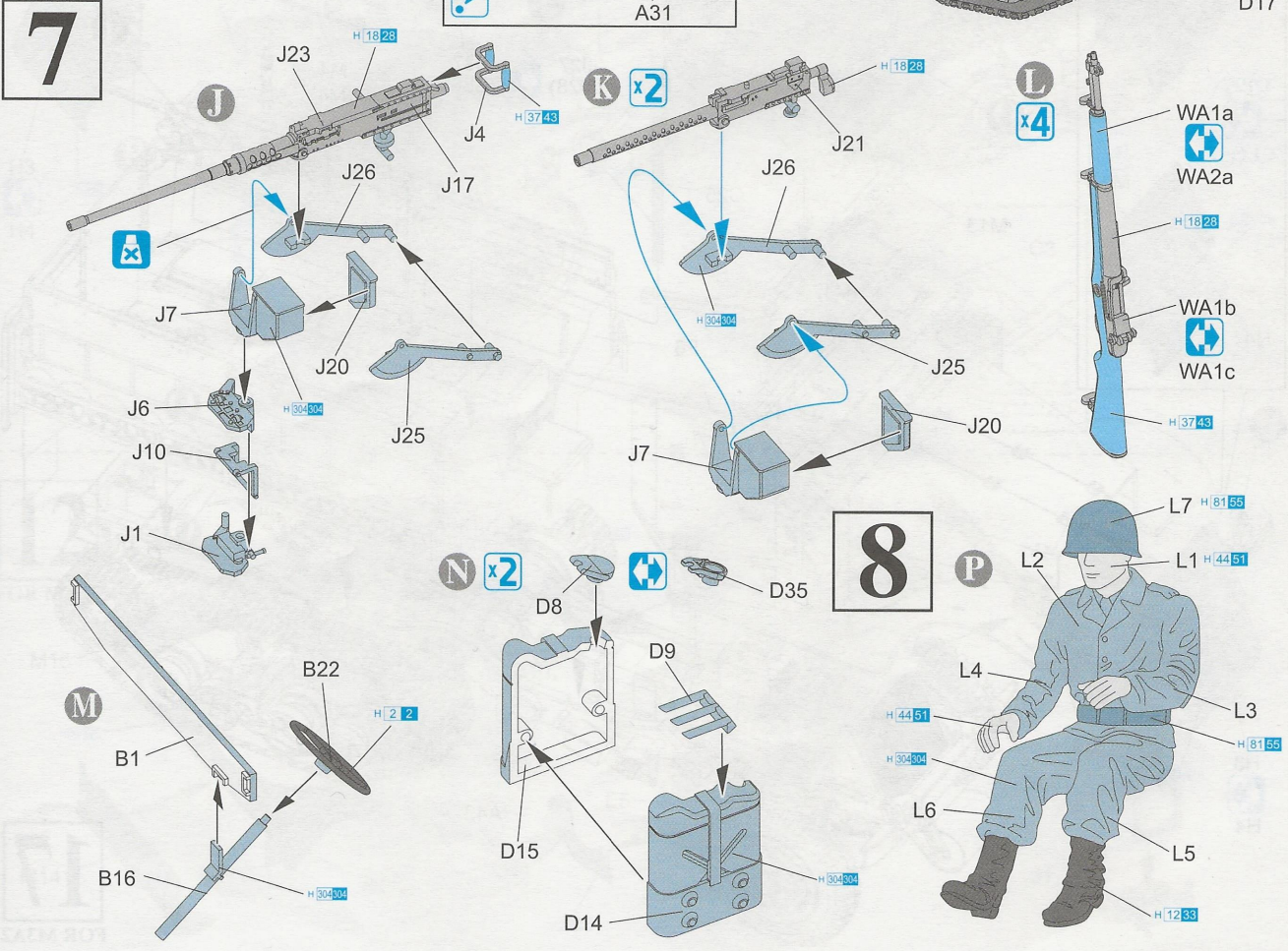
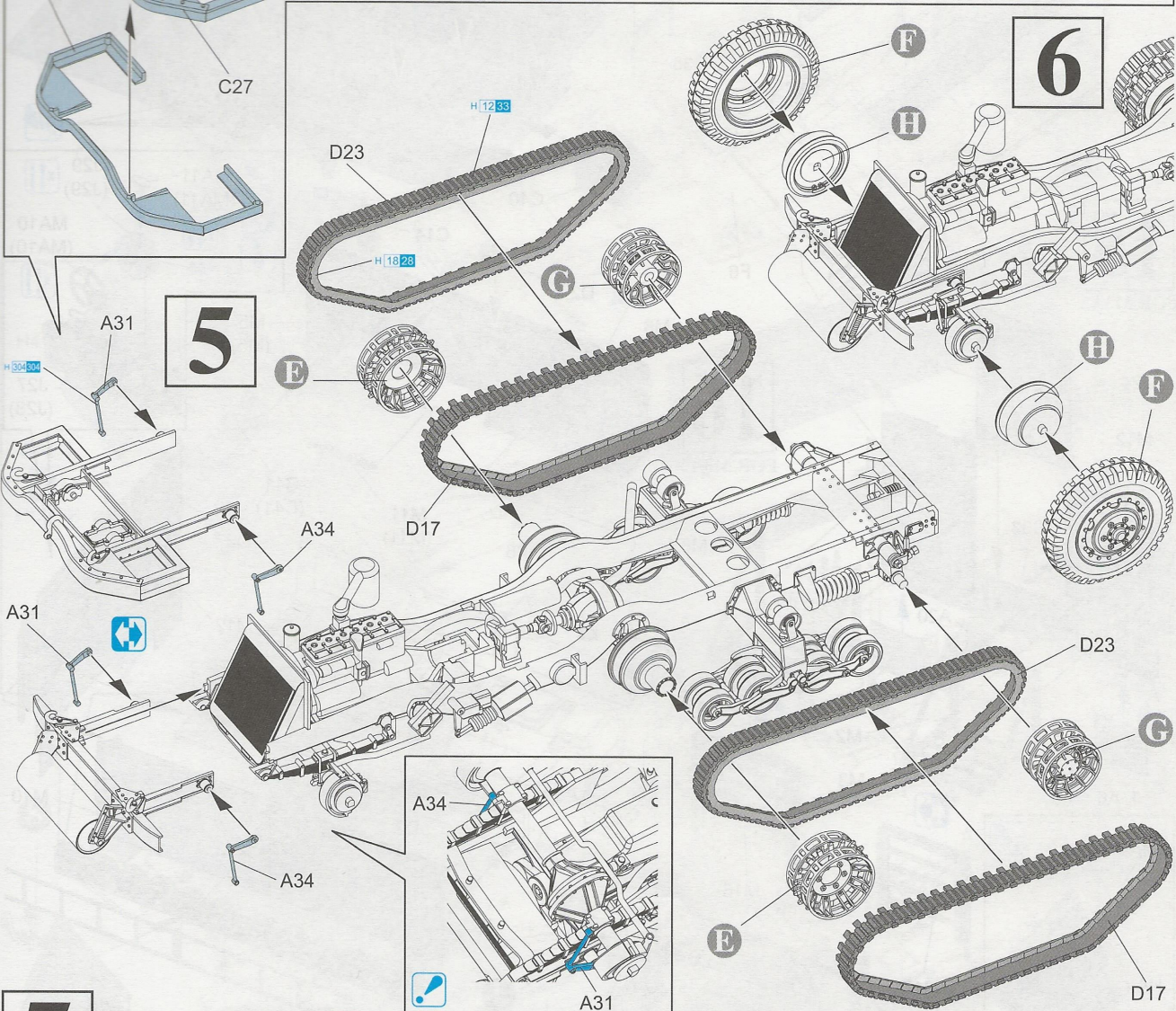

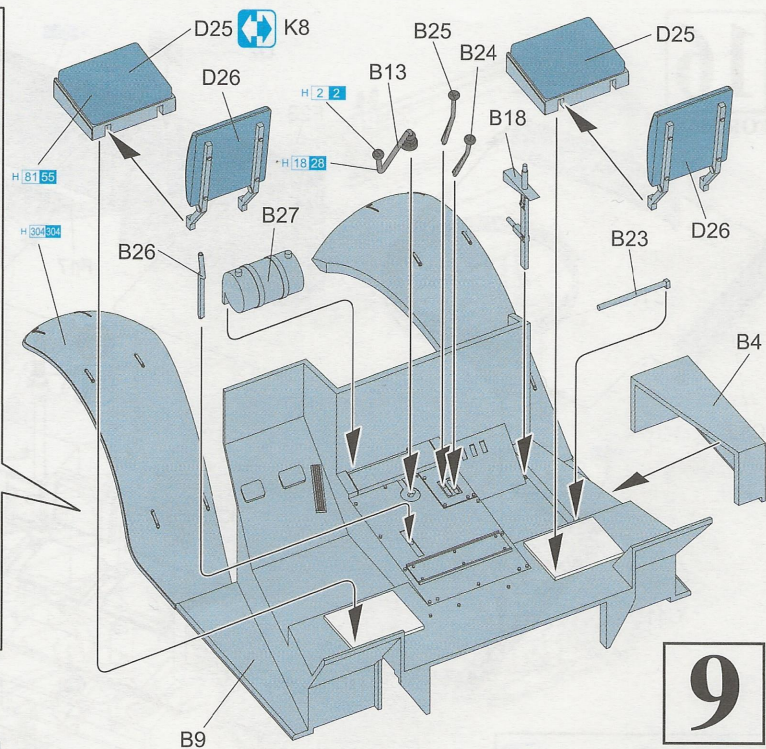
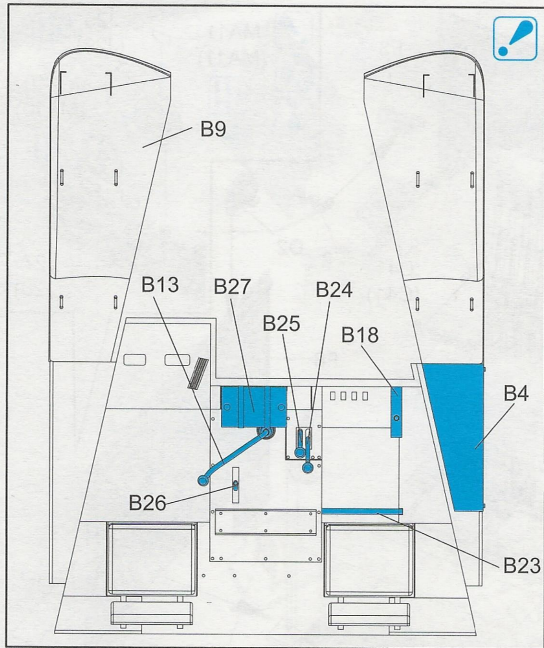

OPEN/
CLOSE



B15

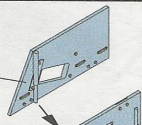

9

OPEN/CLOSE



B15

B9

10

B12

B20

B11



H 304 304

H 2 2

H 3 3

B8

11

E1

B9

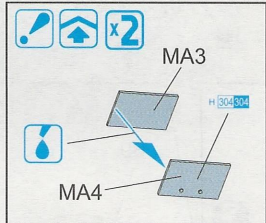

OPEN/CLOSE



B17

MA4 (MA4)



B3

D30

D30

B5

B14

OPEN



OPEN



MA2



MA9

MA9

D4

D4

D4

E1

H 304 304

B3

B5



B19

H 12 33

H 37 43

B21

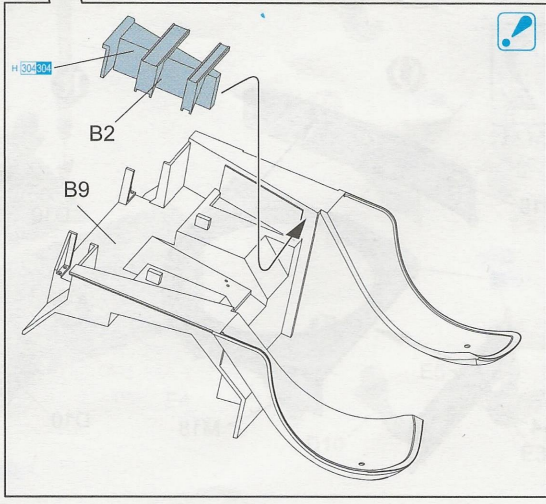

H 304 304

B2

B9

12

FOR M3

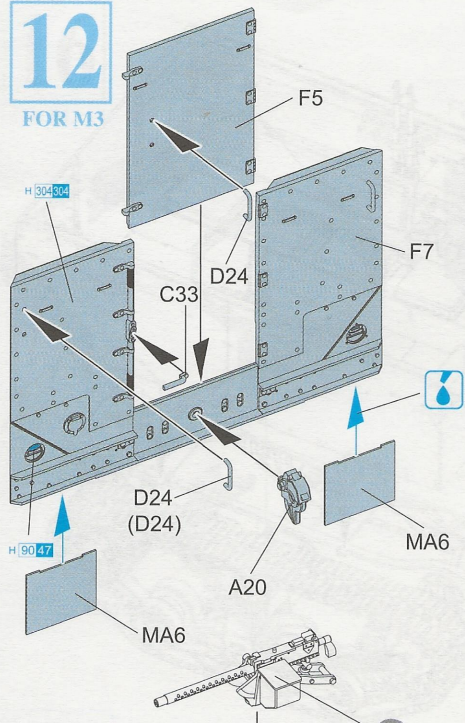

13

FOR M3

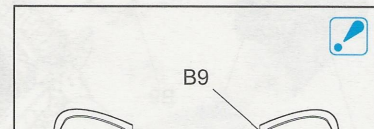
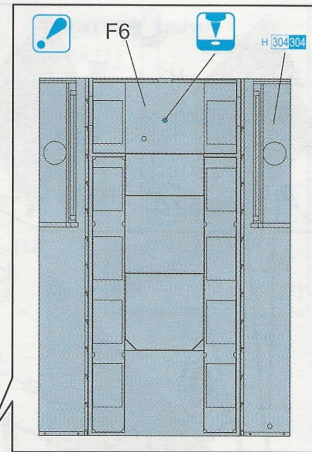
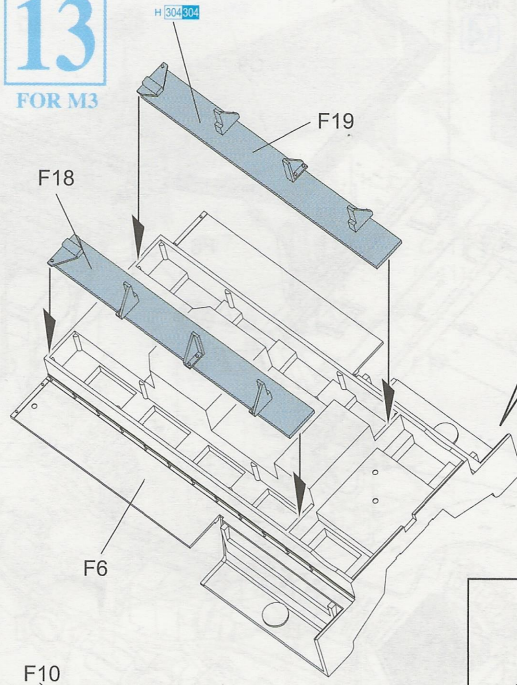

14

FOR M3
OR M3A1

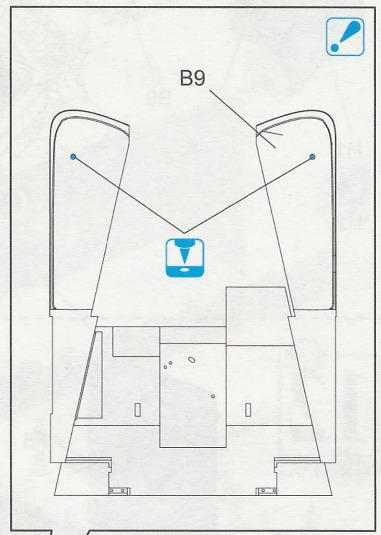
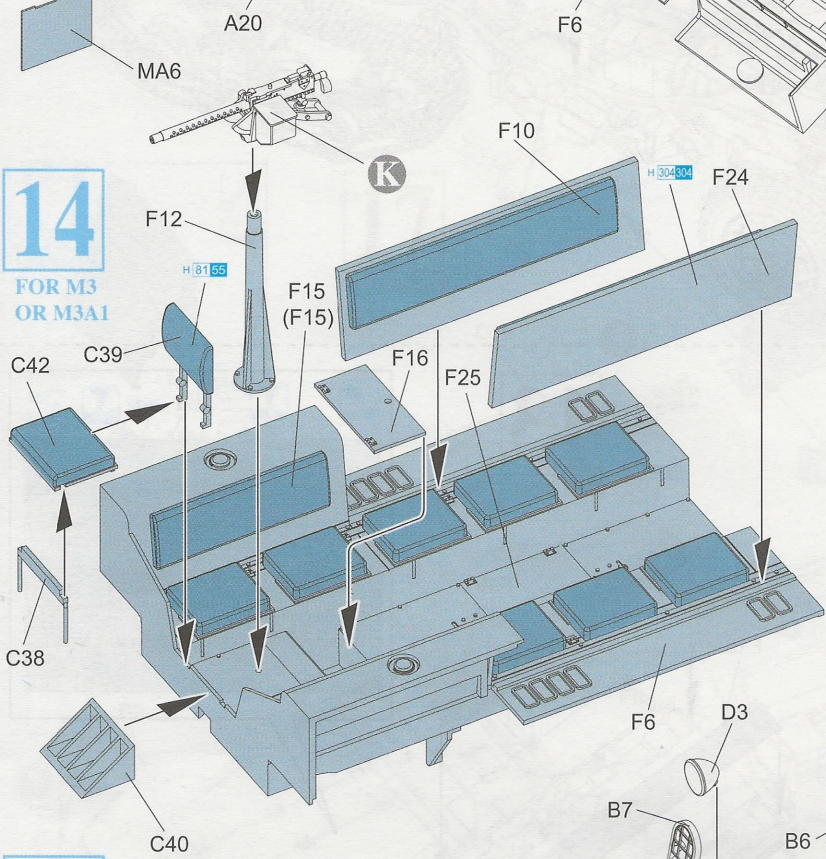

15

FOR M3
OR M3A1

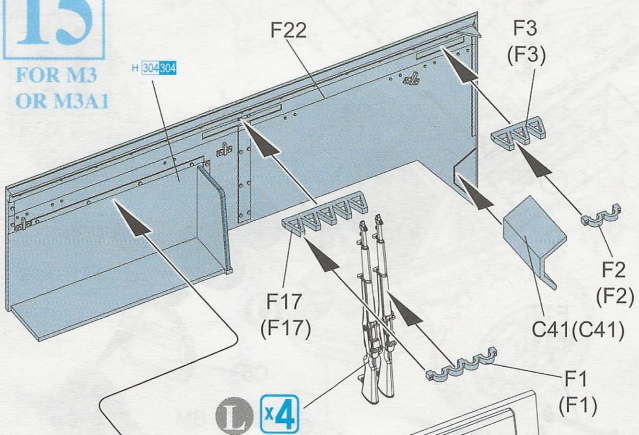

16

FOR M3

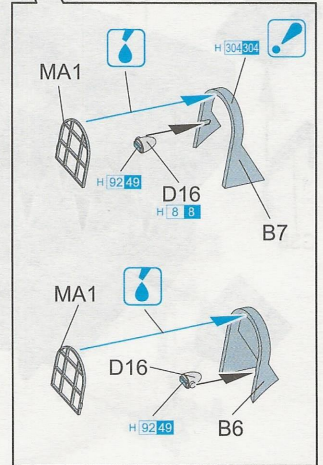
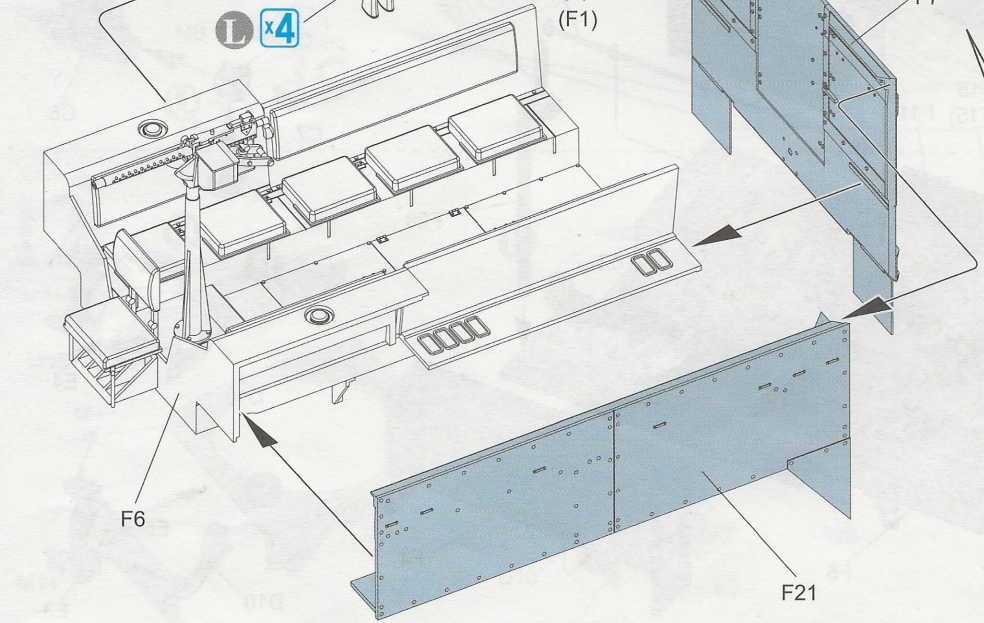
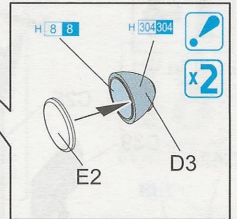
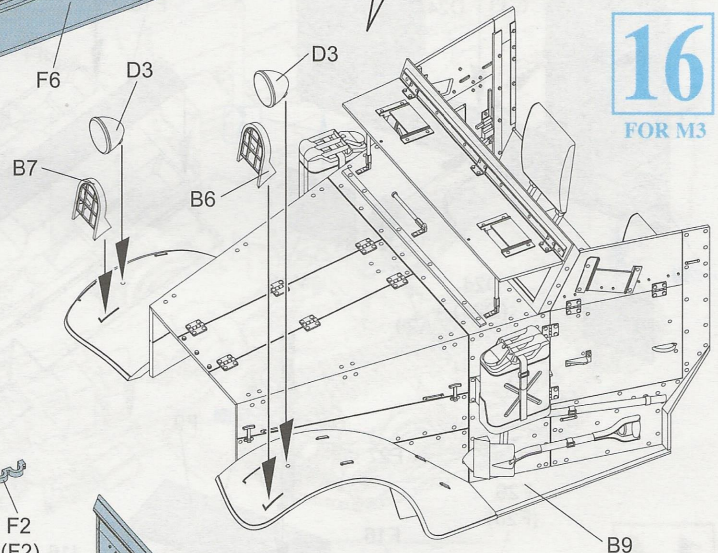

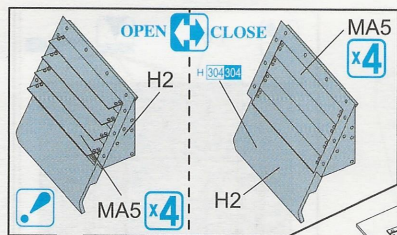

H1

H2

H 304 304

B9

C9

F6

A42

17
FOR M3

12

FOR M3A1

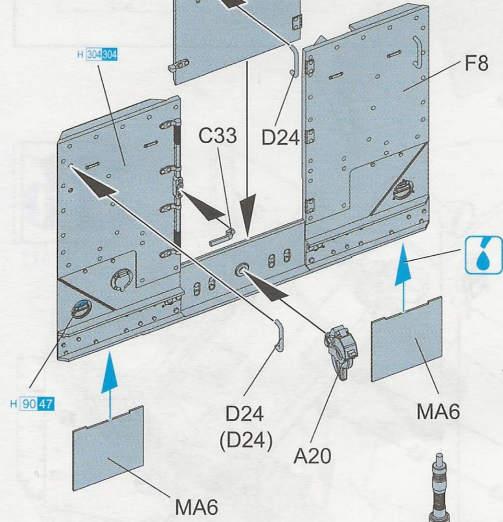

13

FOR M3A1

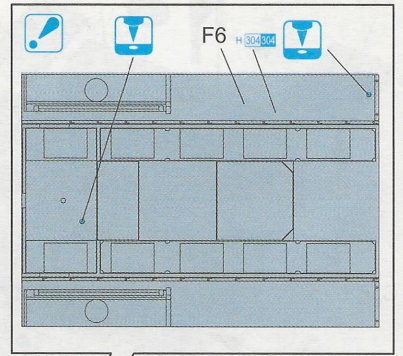
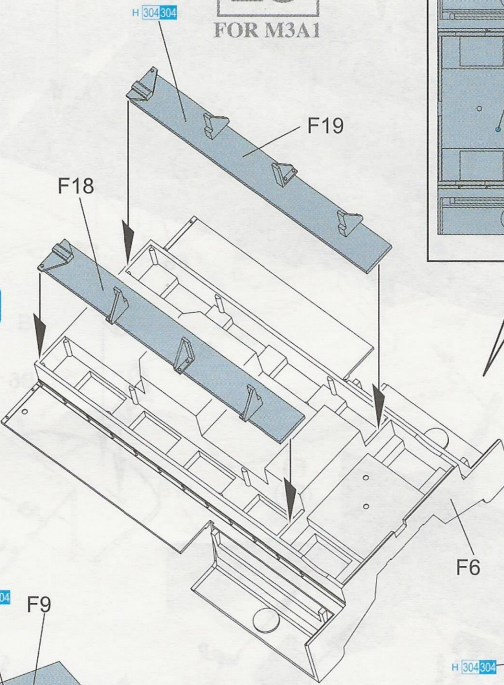

14

FOR M3A1

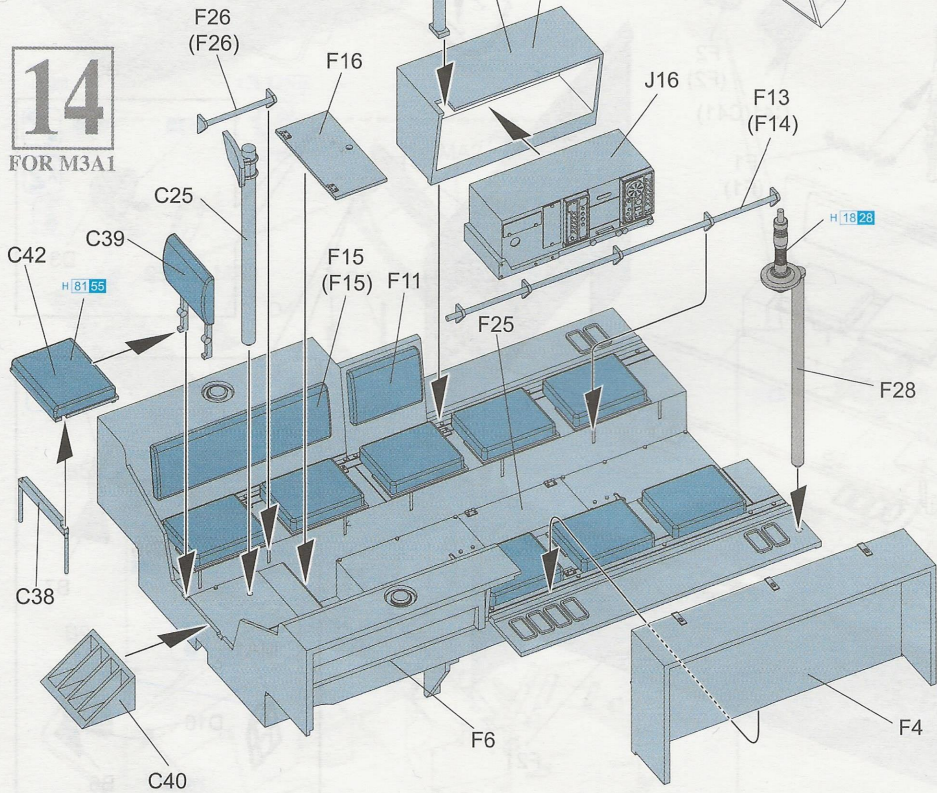

15

FOR M3A1

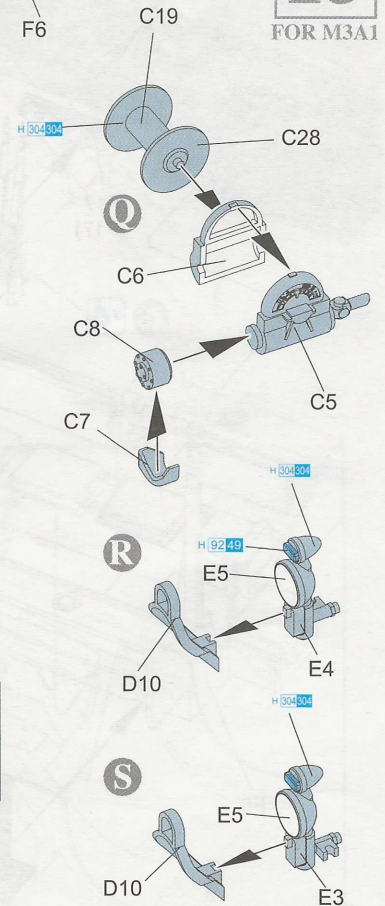

16

FOR M3A1

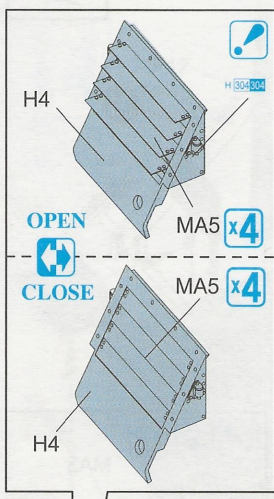
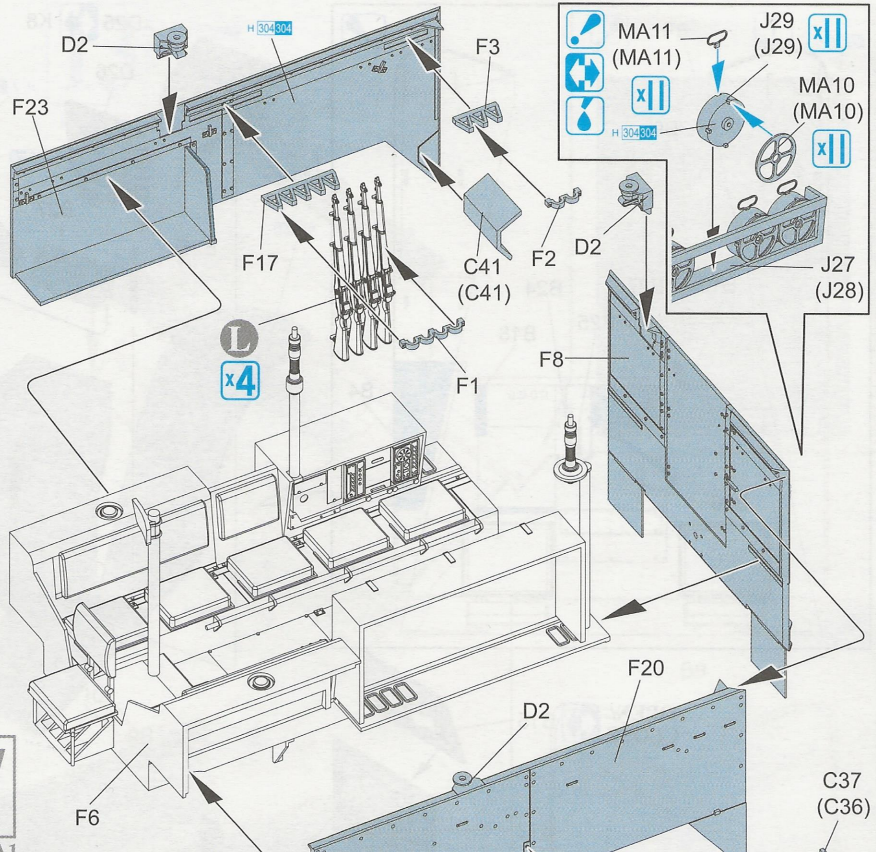
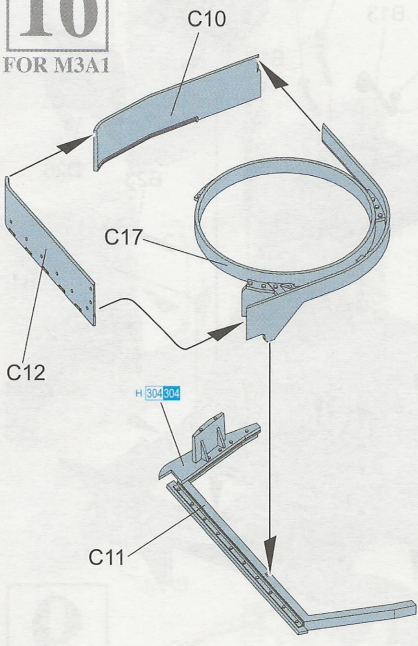

17

FOR M3A1

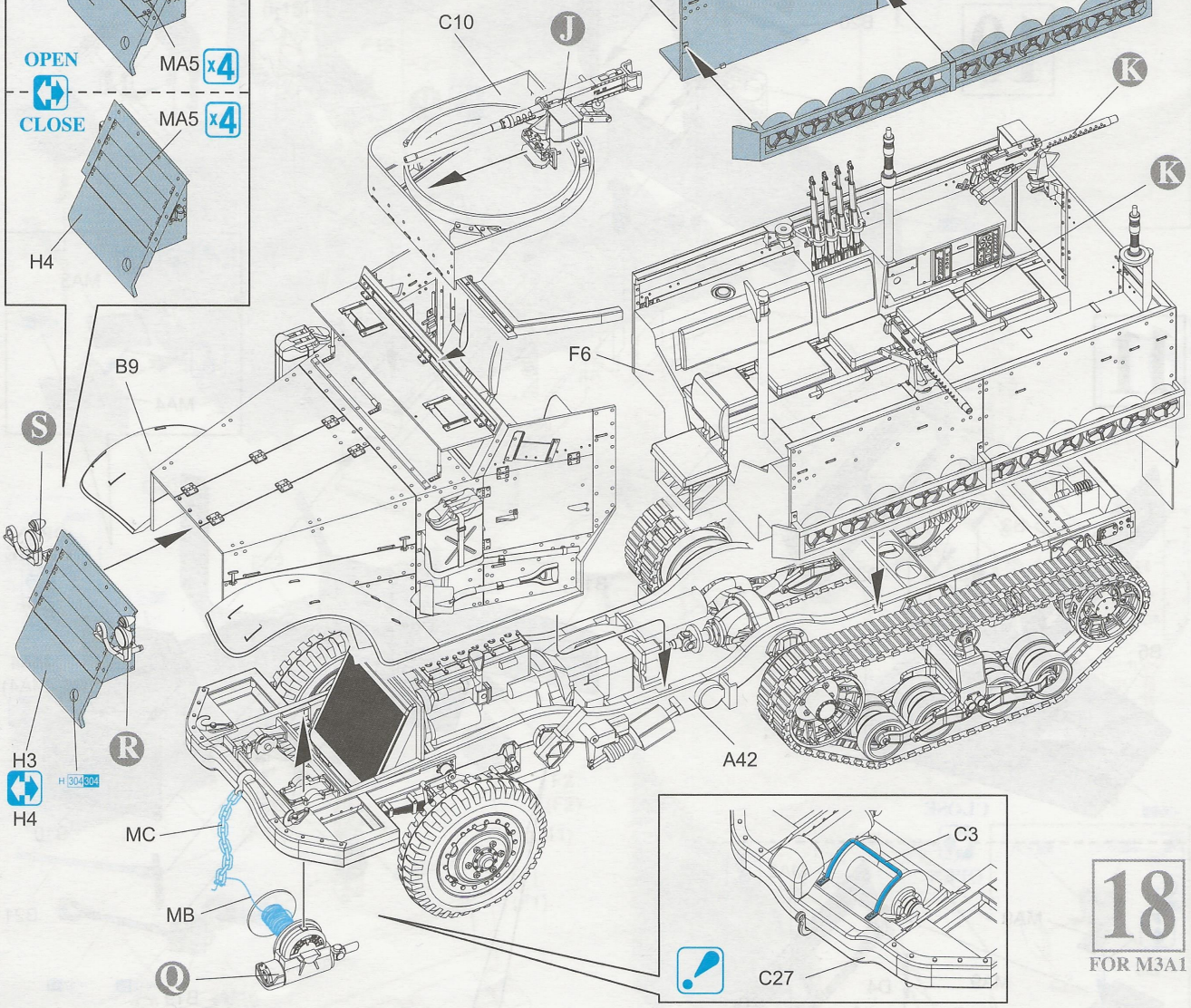

18

FOR M3A1

12

FOR M3A2

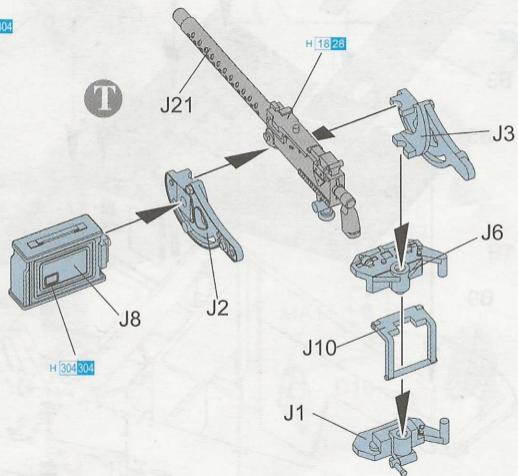
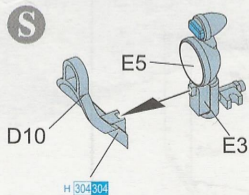
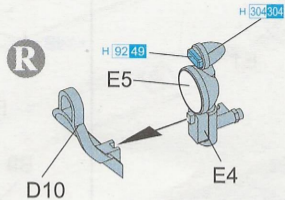
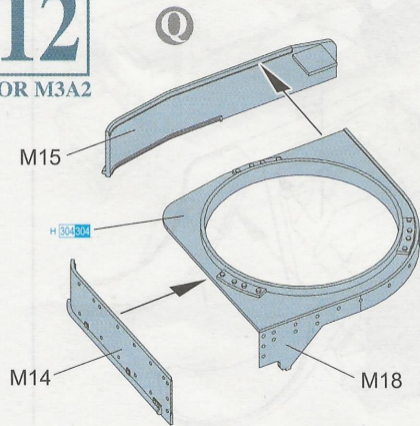

13

FOR M3A2

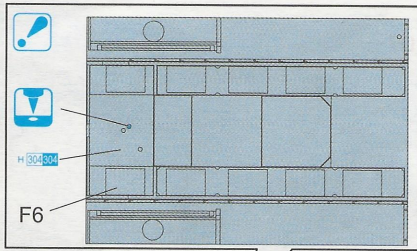

14

FOR M3A2

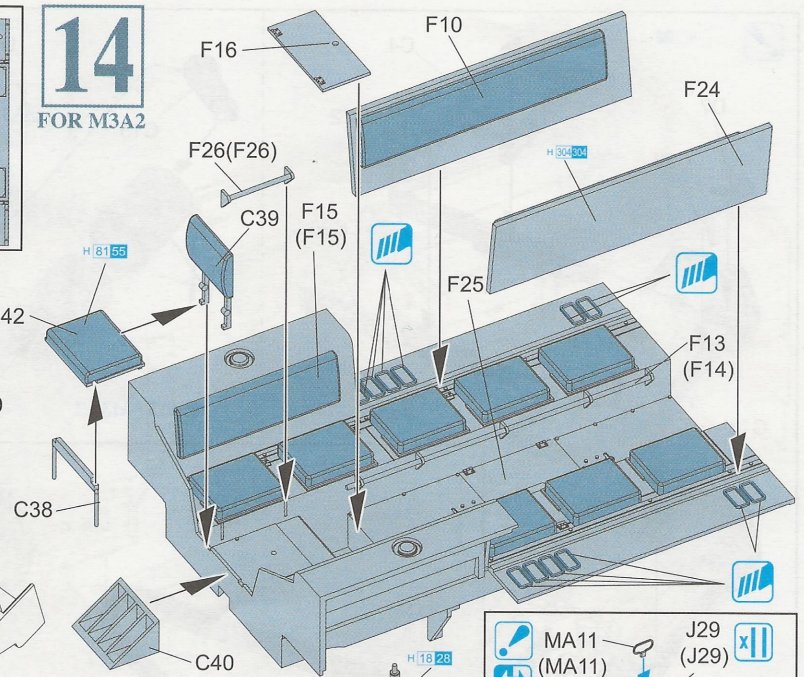

15

FOR M3A2

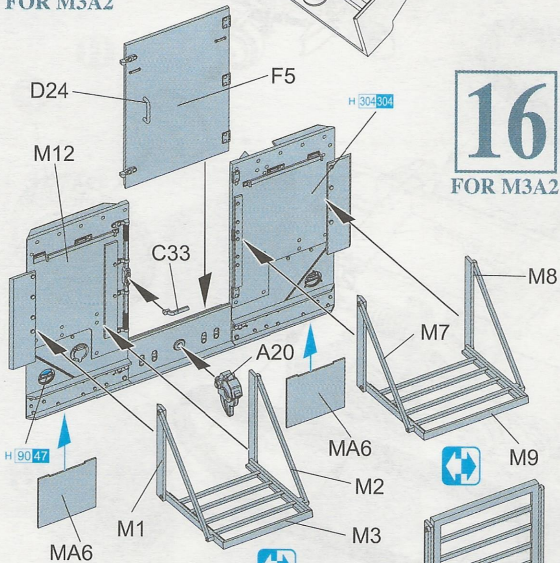

16

FOR M3A2

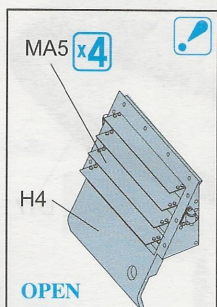
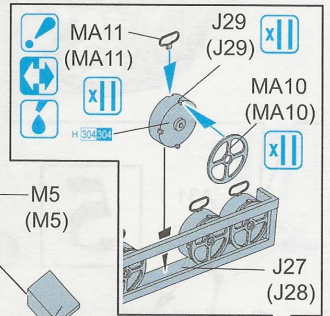
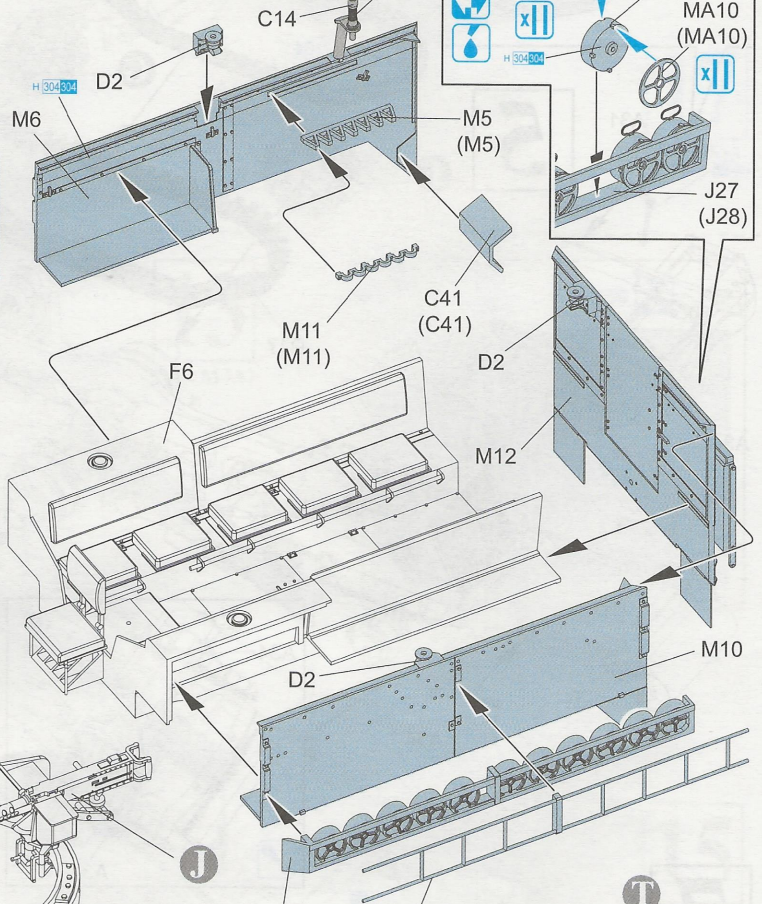

OPEN

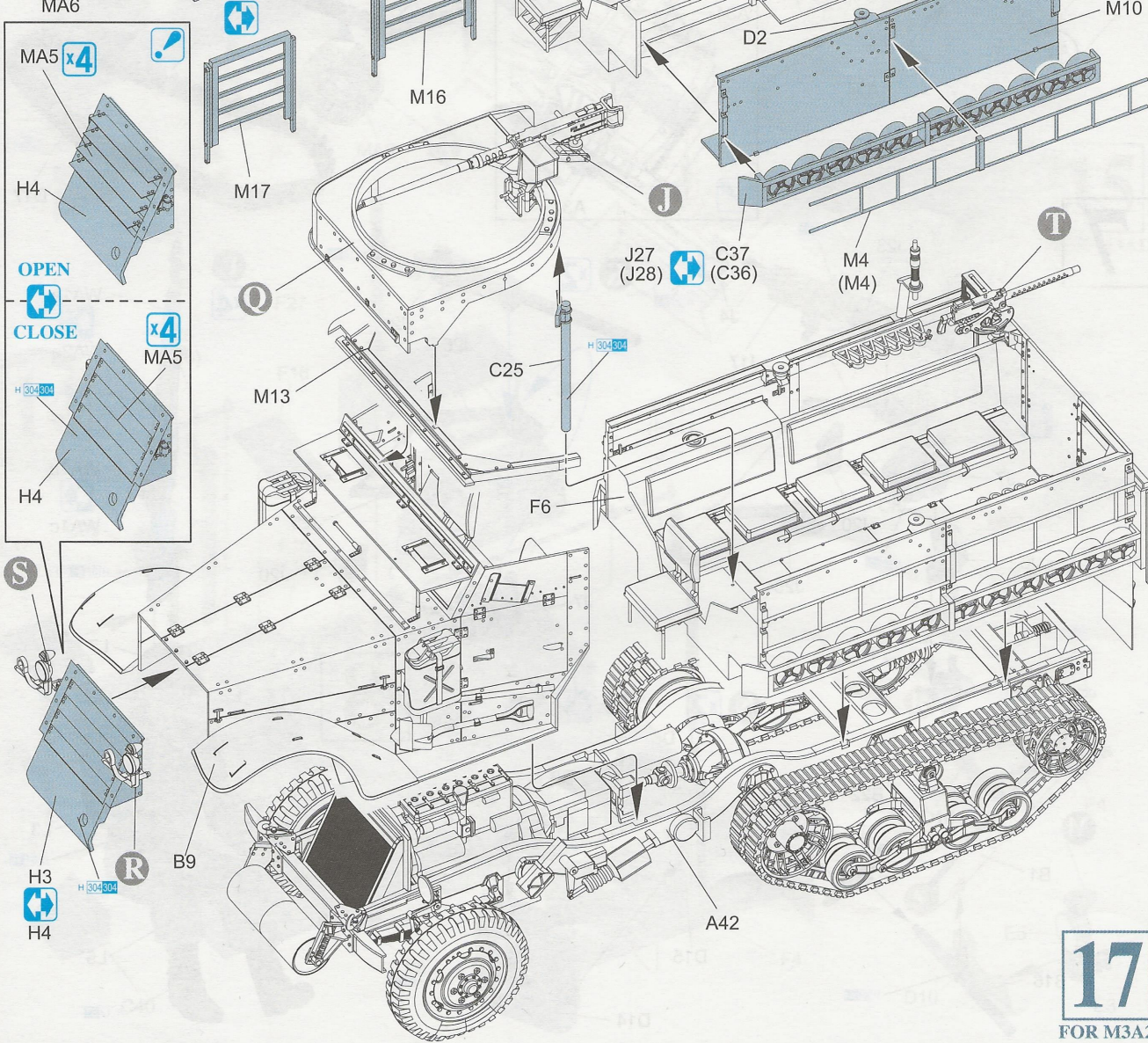

Paint & Markings

マーキング及び塗装図

Markierungen und Bemalung

Decoration et Peinture

Marchio & Pittura

標貼及着色指示

M3A1

4th Armored Division
Germany 1945

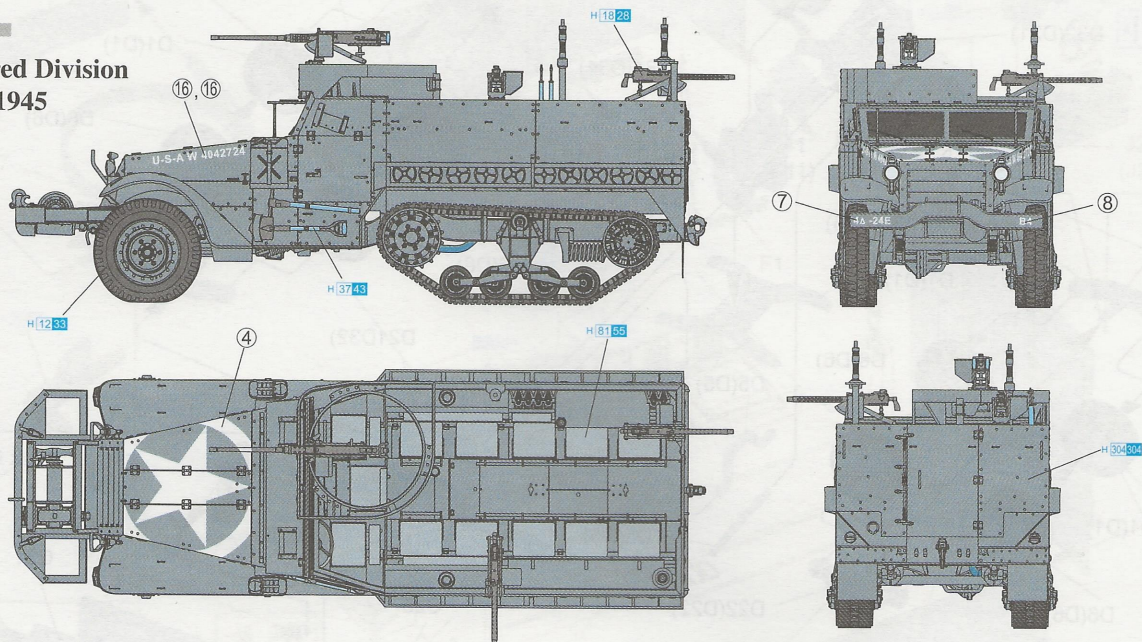

1st Armored Division
France 1944

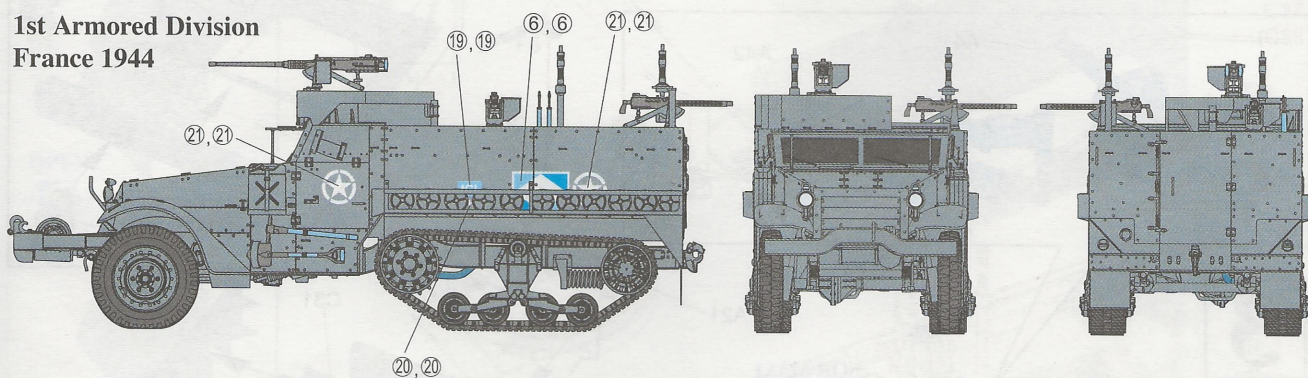

3rd Armored Division
France 1944

