



KIT 5613

85561300200

PBY-5A CATALINA

In World War II, long before there were satellites or other high-tech surveillance equipment, the U.S. Navy relied on long-range flying boats and amphibians to patrol the vast expanses of ocean and search for the enemy. The most numerous of these was the Consolidated Aircraft's PBY Catalina. Perhaps best known for the search patrols that located the Japanese invasion and carrier forces heading for Midway Island in 1942, Catalinas served throughout the war as the Navy's eyes in the sky.

But the versatile use of the Catalina went far beyond that of a patrol craft. Most important to downed airmen was the search and rescue role. Crews of aircraft that had been shot down, as well as sailors from ships that had been sunk, scanned the skies for the approach of a Catalina that would return them to safety. Affectionately called "dumbos" the Catalinas could land in water, pick up the survivors, and take off again in a matter of minutes. Scores of airmen and sailors were rescued from death or capture by Catalinas and returned to duty or taken to medical treatment. Other Catalinas served as VIP transports for high-ranking officers.

This kit includes accurate silk screen decals for two different Catalinas. One from the squadron known as the "SNAFU SNATCHERS" circa 1944 Pacific Theatre. The other based from Hamilton AFB, California circa 1950.



* REPEAT SEVERAL TIMES
* A REPETER PLUSIEURS FOIS



* OPTIONAL PARTS
* PIECES EN OPTION



* DECAL
* DECAL COMANIE



* ALTERNATIVE ASSEMBLY
* ENSEMBLAGE ALTERNATIVE



* CEMENT TOGETHER
* A COLLER



* REMOVE AND THROW AWAY
* A RETIRER ET JETER



* DO NOT CEMENT
* NE PAS COLLER

READ THIS BEFORE YOU BEGIN

- * Study the assembly drawings.
- * Each plastic part is identified by a number.
- * In the assembly drawings, some parts will be marked by a star (★) to indicate chrome plated plastic.
- * For better paint and decal adhesion, wash the plastic parts in a mild detergent solution. Rinse and let air dry.
- * Check the fit of each piece before cementing in place.
- * Use only cement for polystyrene plastic.
- * Scrape plating and paint from areas to be cemented.
- * Allow paint to dry thoroughly before handling parts.
- * Any unused parts may be discarded.

DECAL APPLICATION INSTRUCTIONS

1. Cut desired decal from sheet.
2. Dip decal in water for a few seconds.
3. Place wet decal on paper towel.
4. Wait until decal is movable on paper backing.
5. Place decal in position on model, face up and slide backing away.
6. Press out air bubbles with a soft damp cloth.
7. Milkiness that may appear is for better decal adhesion and will dry clear. Wipe away any excess adhesive.
8. Do not touch decal until fully dry.
9. Allow the decals 48 hours to dry before applying clear coat.

NOTE: Decals are compatible with setting solutions or solvents.

LIRE CE QUI SUIT AVANT DE COMMENCER

- * Etudier les schémas de montage.
- * Chaque pièce en plastique est identifiée par un numéro.
- * Sur les schémas de montage, certaines pièces sont marquées d'une étoile (★) pour indiquer qu'elles sont en plastique chromé.
- * Pour une meilleure prise de la peinture et des autocollants, laver les pièces en plastique avec une solution détergente peu concentrée. Les rincer et les laisser sécher à l'air.
- * Vérifier que chaque pièce s'ajuste bien avant de la coller en place.
- * N'utiliser que de la colle pour polystyrène.
- * Gratter les parties à coller pour enlever le chrome et la peinture.
- * Laisser la peinture bien sécher avant de manipuler les pièces.
- * Toute pièce inutilisée peut être jetée.

DIRECTIVES D'APPLICATION DES AUTOCOLLANTS

1. Découper l'autocollant désiré de la feuille.
2. Tremper l'autocollant dans de l'eau pendant quelques secondes.
3. Placer l'autocollant mouillé sur une serviette en papier.
4. Attendez que l'autocollant puisse être déplacé sur son support en papier.
5. Mettre l'autocollant en position sur le modèle face sur le dessus et faire glisser le support pour l'enlever.
6. Appuyer avec un chiffon doux humide pour éliminer les bulles d'air.
7. La substance laiteuse qui peut apparaître est destinée à améliorer l'adhésion de l'autocollant et devient incolore au séchage. Essuyer pour enlever tout excédent d'adhésif.
8. Ne pas toucher l'autocollant tant qu'il n'est pas bien sec.
9. Laisser l'autocollant sécher pendant 48 heures avant d'appliquer une couche transparente.

REMARQUE: Les autocollants sont compatibles avec les solutions de fixation ou les solvants.

This paint guide is provided to complete this kit as shown on the box.

Ce guide de peinture est fourni pour reproduire le modèle réduit qui apparaît sur la boîte.

Blue Gray	FS 35189	Bleu gris
Chromate Green Primer		Vert chromate Apprêt
Dark Gray	FS 36118	Gris foncé
Flat Black		Noir mat
Flat Brown	FS 30266	Brun mat
Flat White		Blanc mat
Flesh		Chair
Insignia Red	FS 11136	Rouge emblème
Light Gray	FS 36440	Gris clair
Military Brown	FS 30118	Brun militaire
Olive Drab	FS 34088	Olivet
Rubber		Caoutchouc
Silver		Argent
Steel		Acier
Yellow		Jaune

If you have any questions or comments, call our hotline at: **(800) 833-3570**
or, please write to:

Revell-Monogram Consumer Service Department, 8601 Waukegan Road, Morton Grove, Illinois 60053

Be sure to include the plan number (85561300200), part number, description, your return address and phone number.

Visit our website: www.revell-monogram.com

1

FIGURES AND COCKPIT ASSEMBLY

NOTE: FLIGHT UNIFORMS - FLAT BROWN. SHOES AND GLOVES - MILITARY BROWN. LIFE VEST - YELLOW WITH FLAT WHITE STRAPS. SHOULDER HARNESES, LAP BELTS - FLAT WHITE WITH SILVER BUCKLES. SOFT HELMETS - MILITARY BROWN. GOGGLES - MILITARY BROWN OR GRAY. HEADPHONES - FLAT BLACK WITH BROWN STRAPS

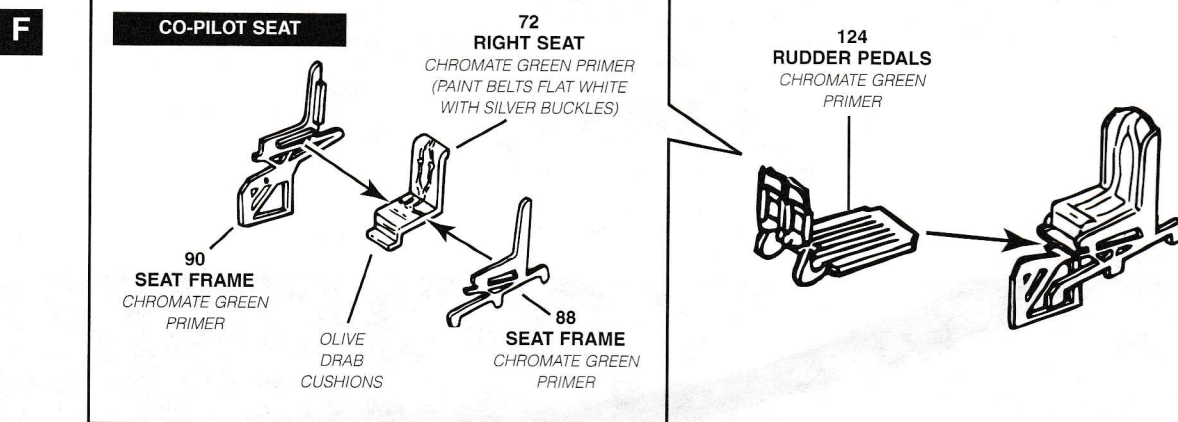
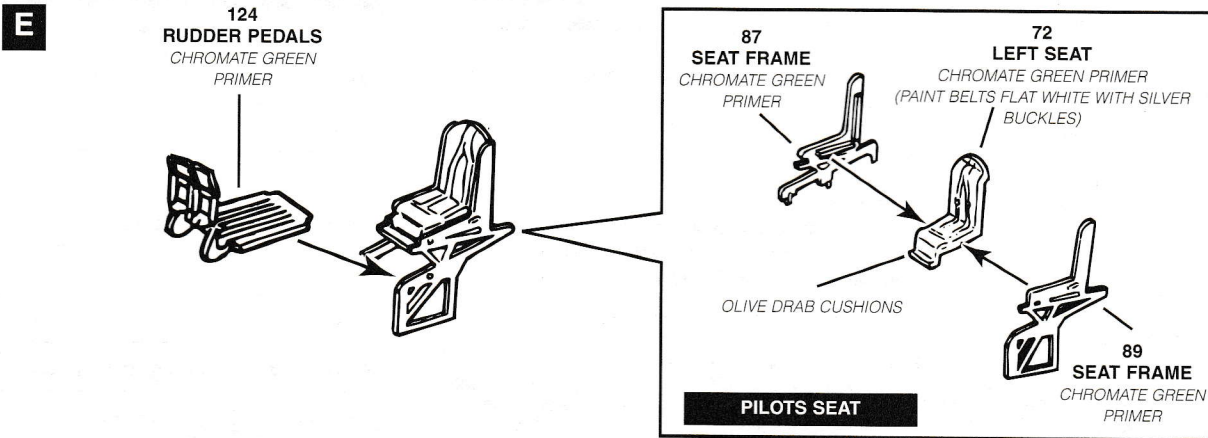
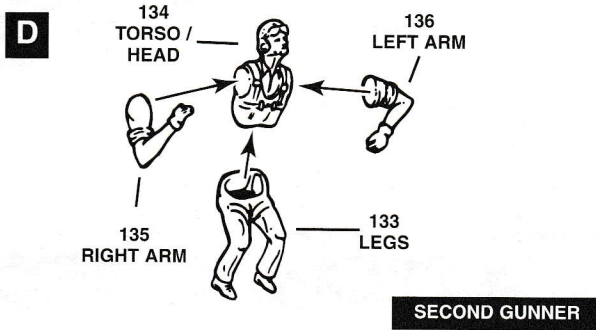
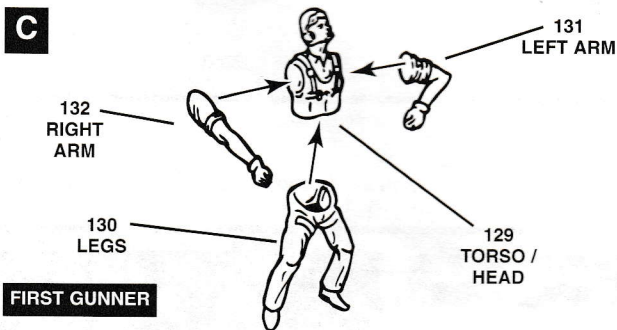
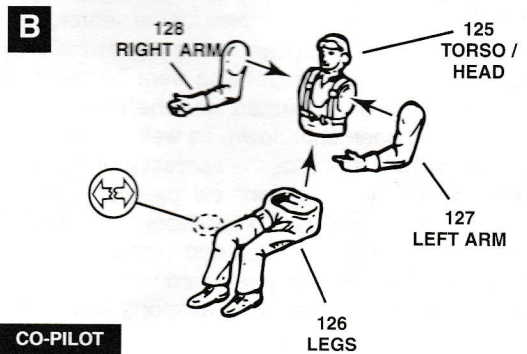
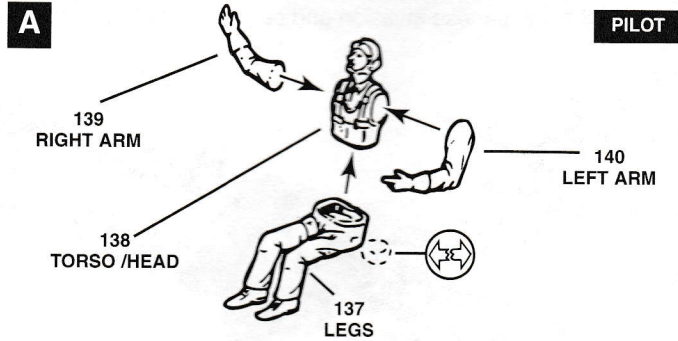

1

FIGURES AND COCKPIT ASSEMBLY CONTINUED

G

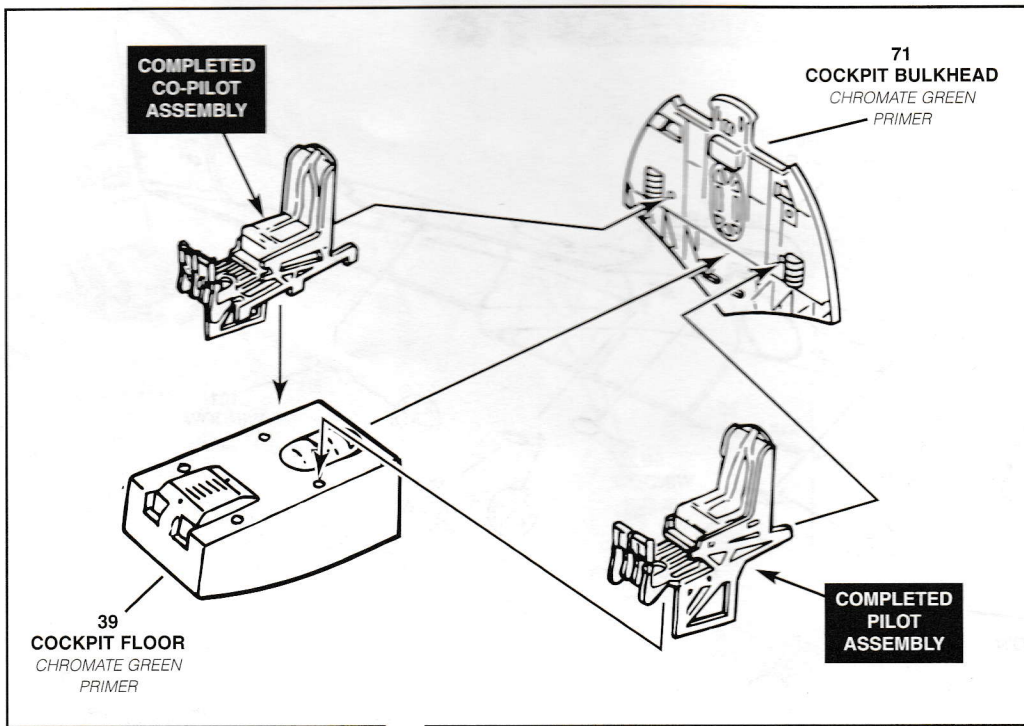

* ? NOTE: FIGURES ARE OPTIONAL

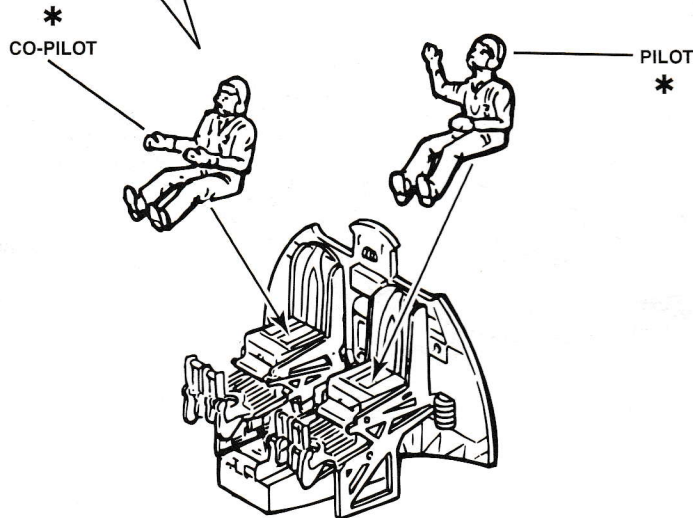

H

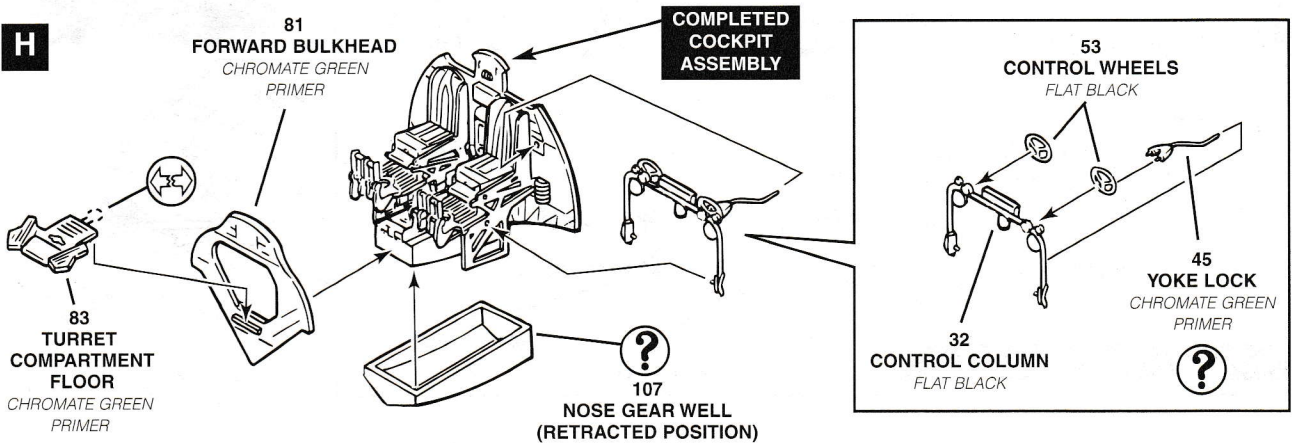

2

WINDOW AND LANDING GEAR ASSEMBLY

A

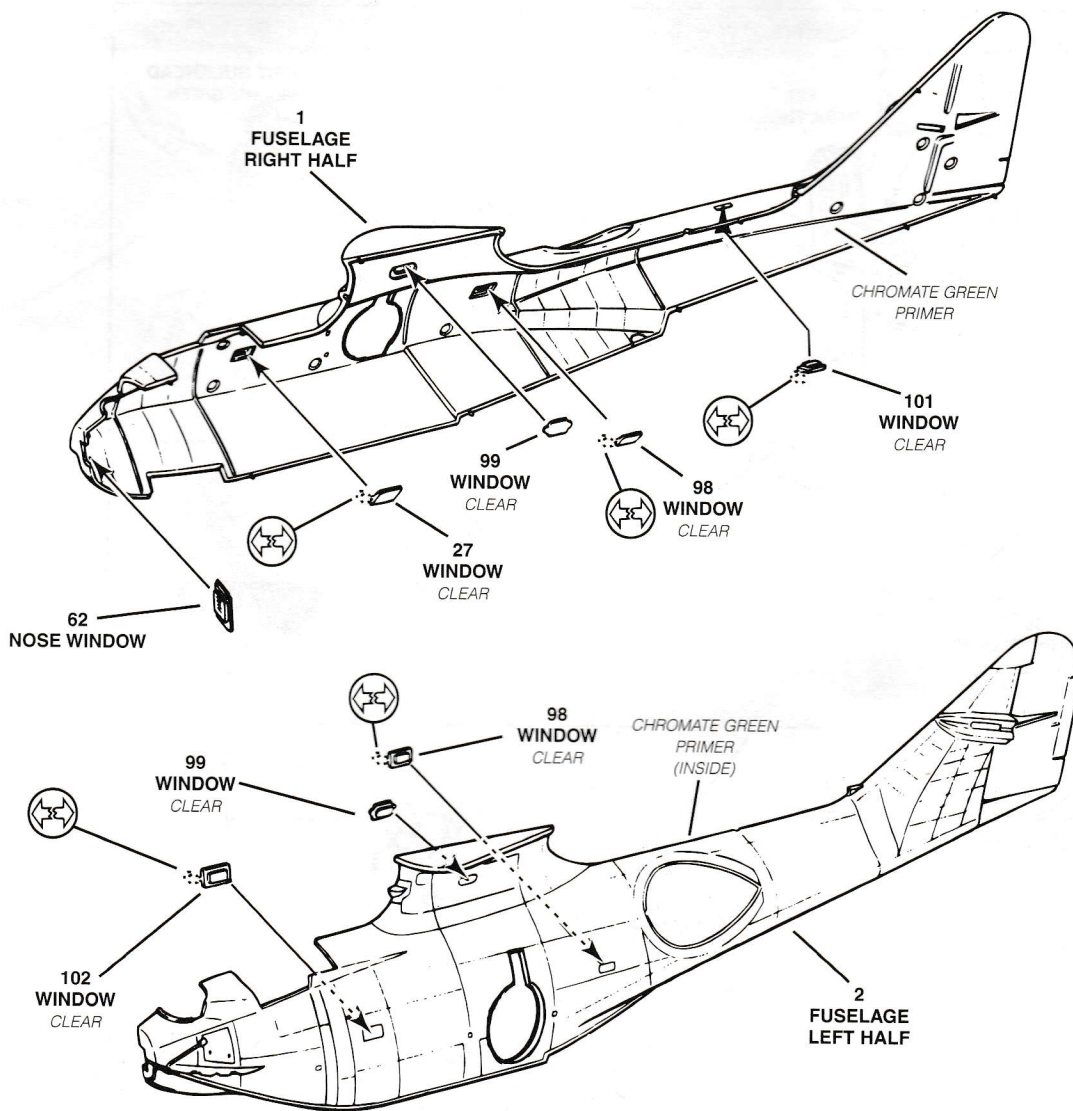

B

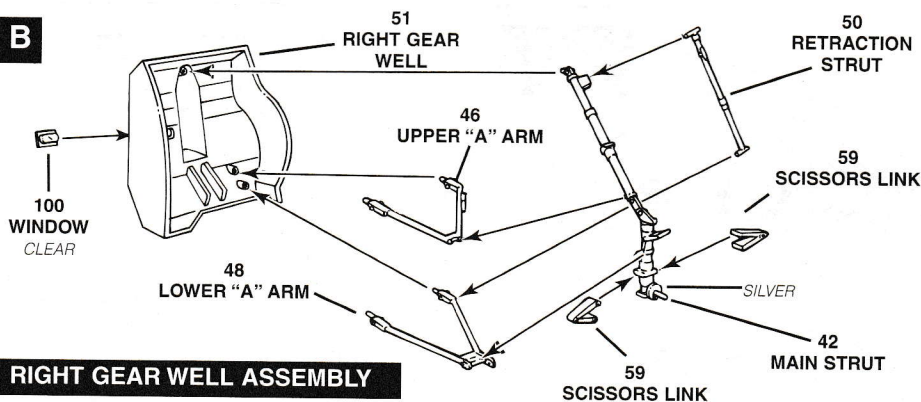

RIGHT GEAR WELL ASSEMBLY

COMPLETED RIGHT GEAR WELL

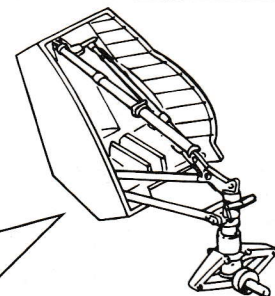

C

LEFT GEAR WELL ASSEMBLY

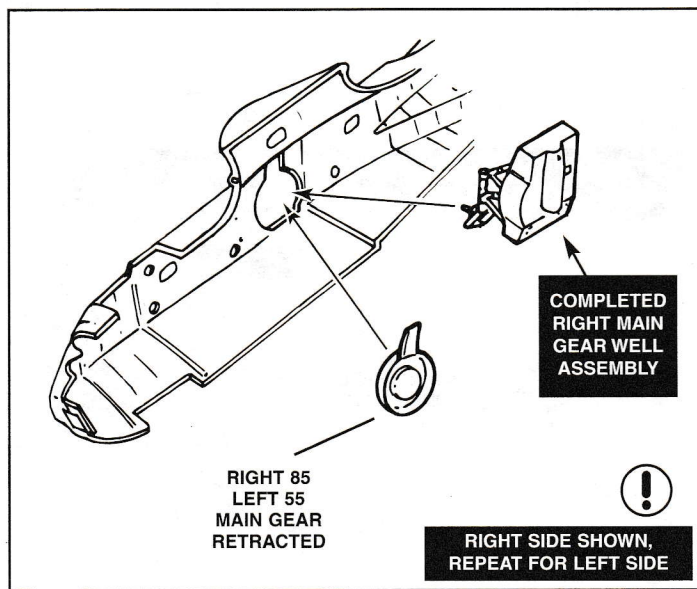
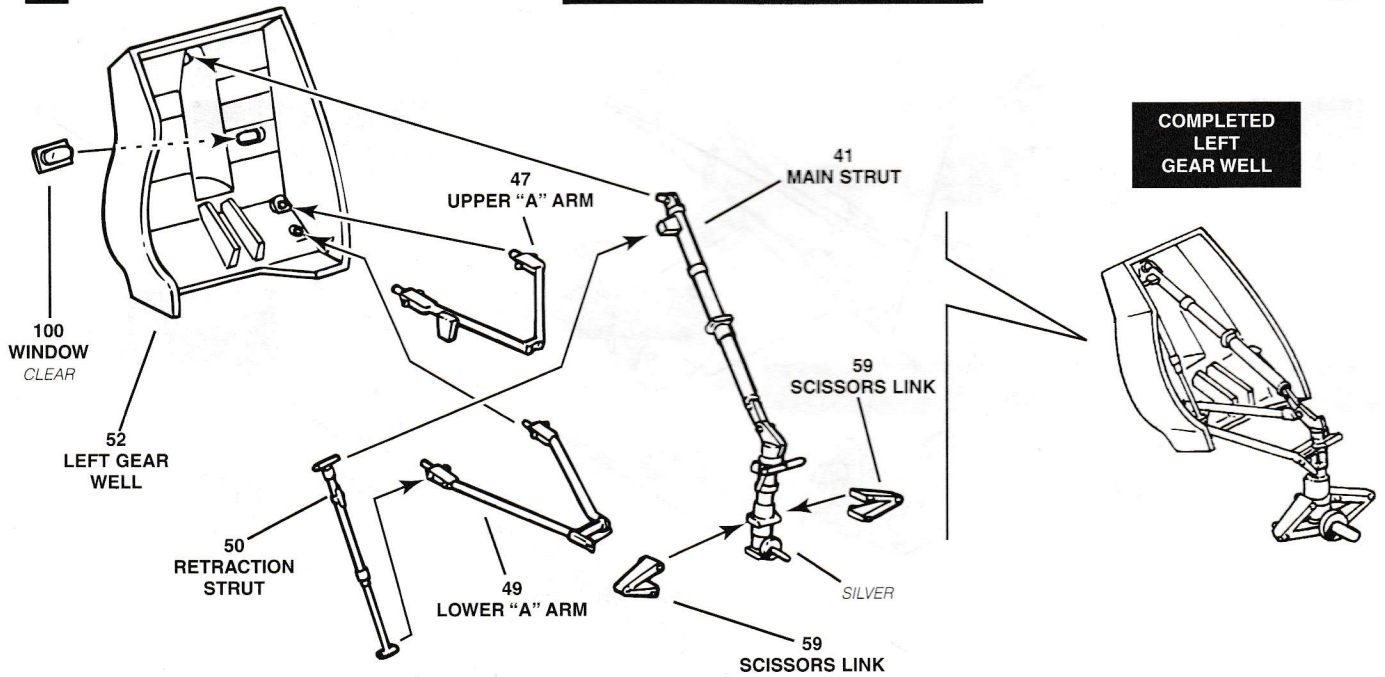

RETRACTED GEAR FROM THE OUTSIDE

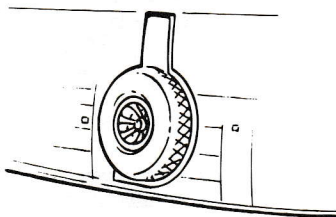

73 MAIN BULKHEAD
CHROMATE GREEN PRIMER

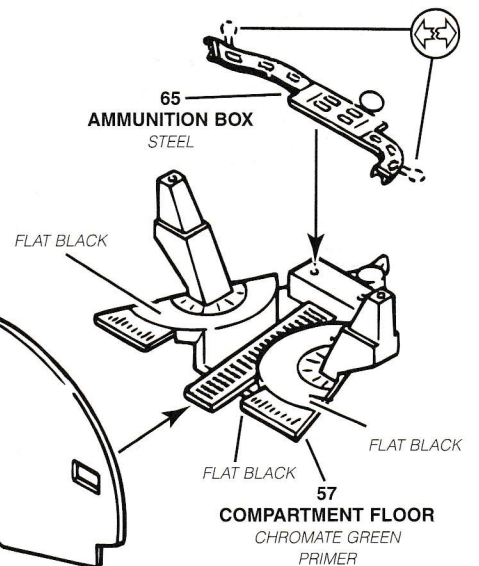

3

INTERIOR AND WHEEL ASSEMBLY

A

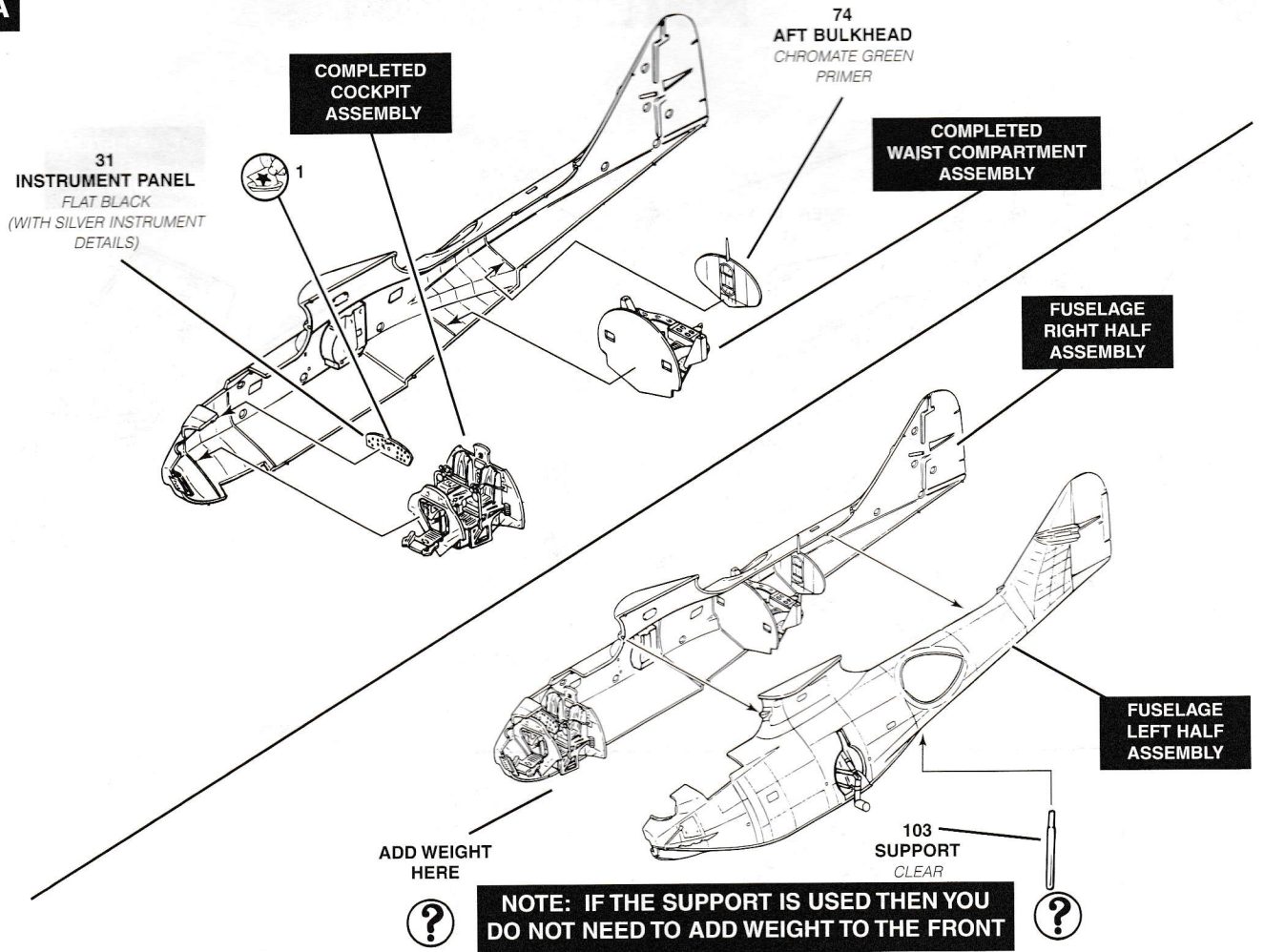

B

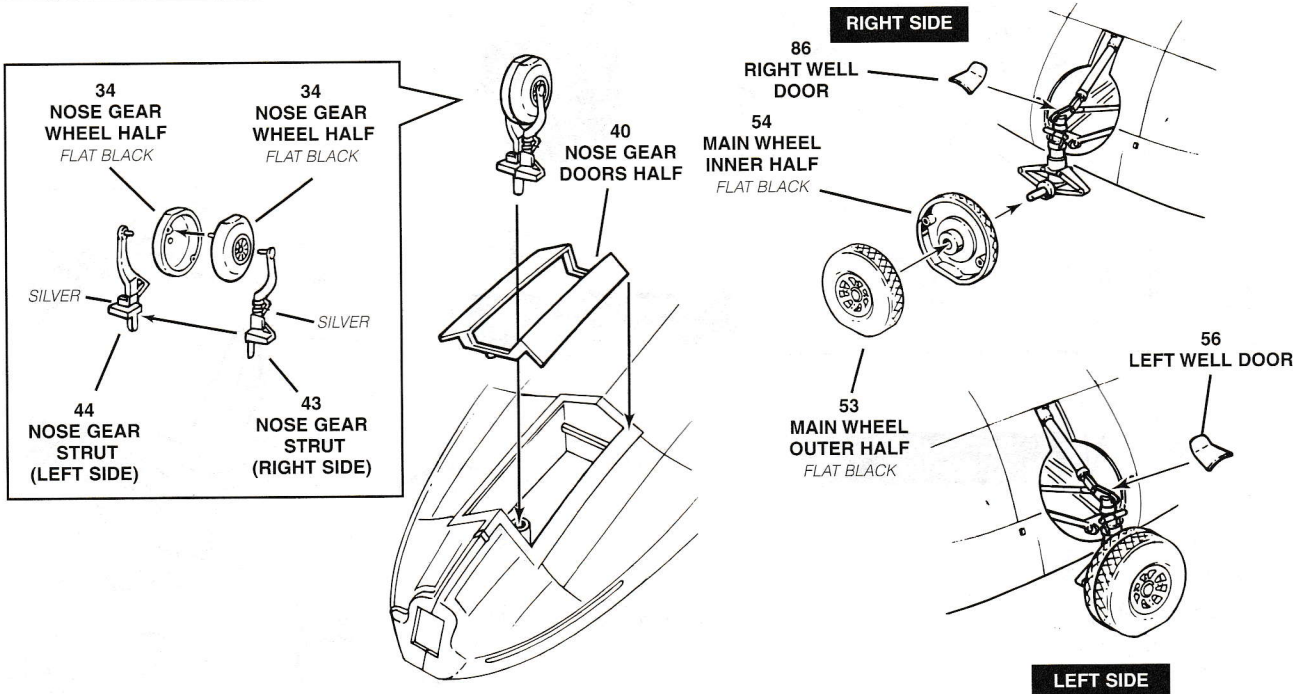

4

FUSELAGE DETAIL ASSEMBLY

A

LEFT SIDE

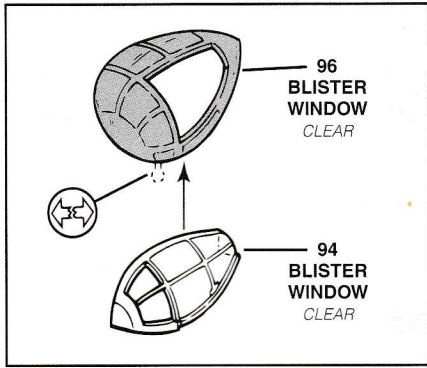

CLOSED BLISTER

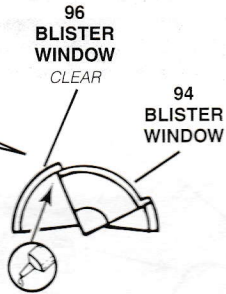

OPEN BLISTER

NOTE: DO NOT INCLUDE FIGURES WHEN ASSEMBLING THE CLOSED POSITION OF THE CANOPY



NOTE: REPEAT FOR RIGHT SIDE USING 95 AND 97

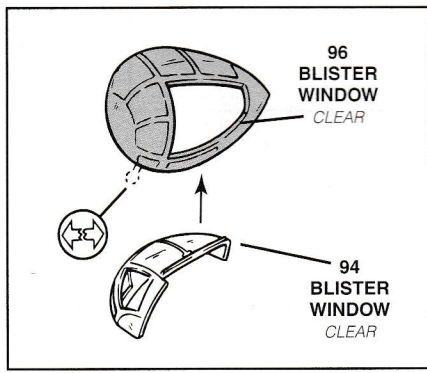

OPEN BLISTER

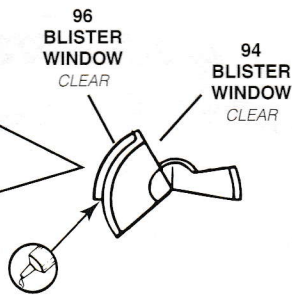

B



77 GUN SHIELD
FLAT BLACK

122 GUN SHIELD
FLAT BLACK

123 MACHINE GUN
GUNMETAL

63 MACHINE GUN
GUNMETAL

NOTE: DO NOT INCLUDE GUNNERS OR MACHINE GUNS FOR RESCUE VERSION

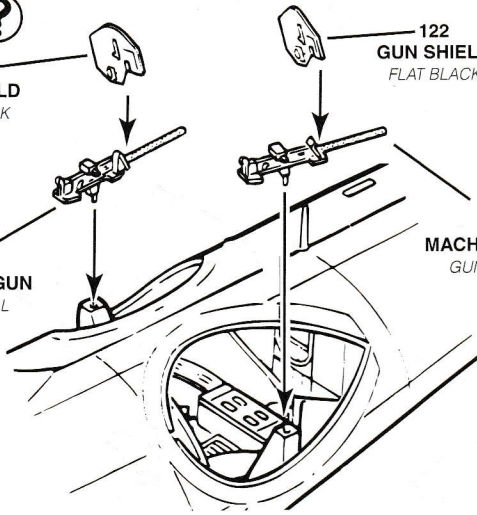

COMPLETED SECOND GUNNER ASSEMBLY

COMPLETED FIRST GUNNER ASSEMBLY

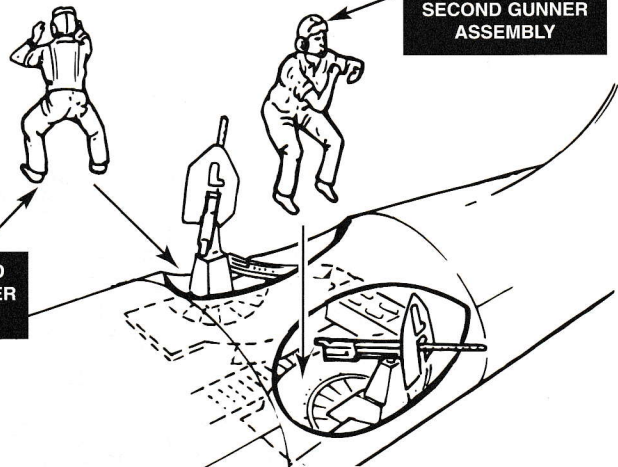

C



NOTE: THE BUG EYE TURRET IS NOT USED FOR THE RESCUE VERSION. IT IS OPTIONAL FOR THE WWII VERSION

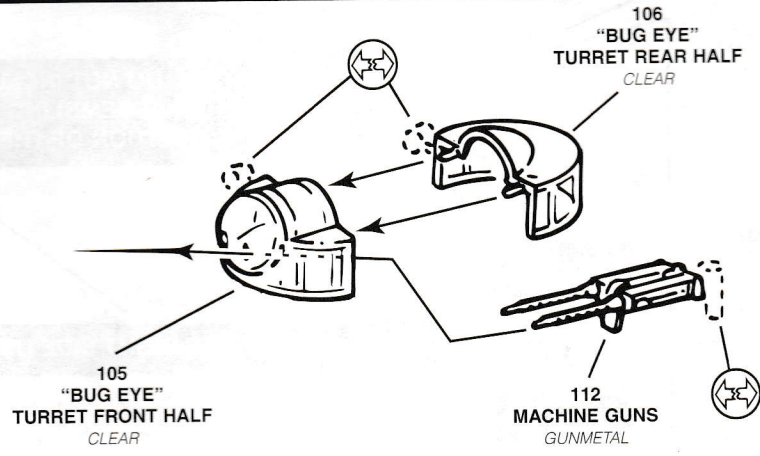

NOTE: EXTRA PARTS MAY BE DISCARDED

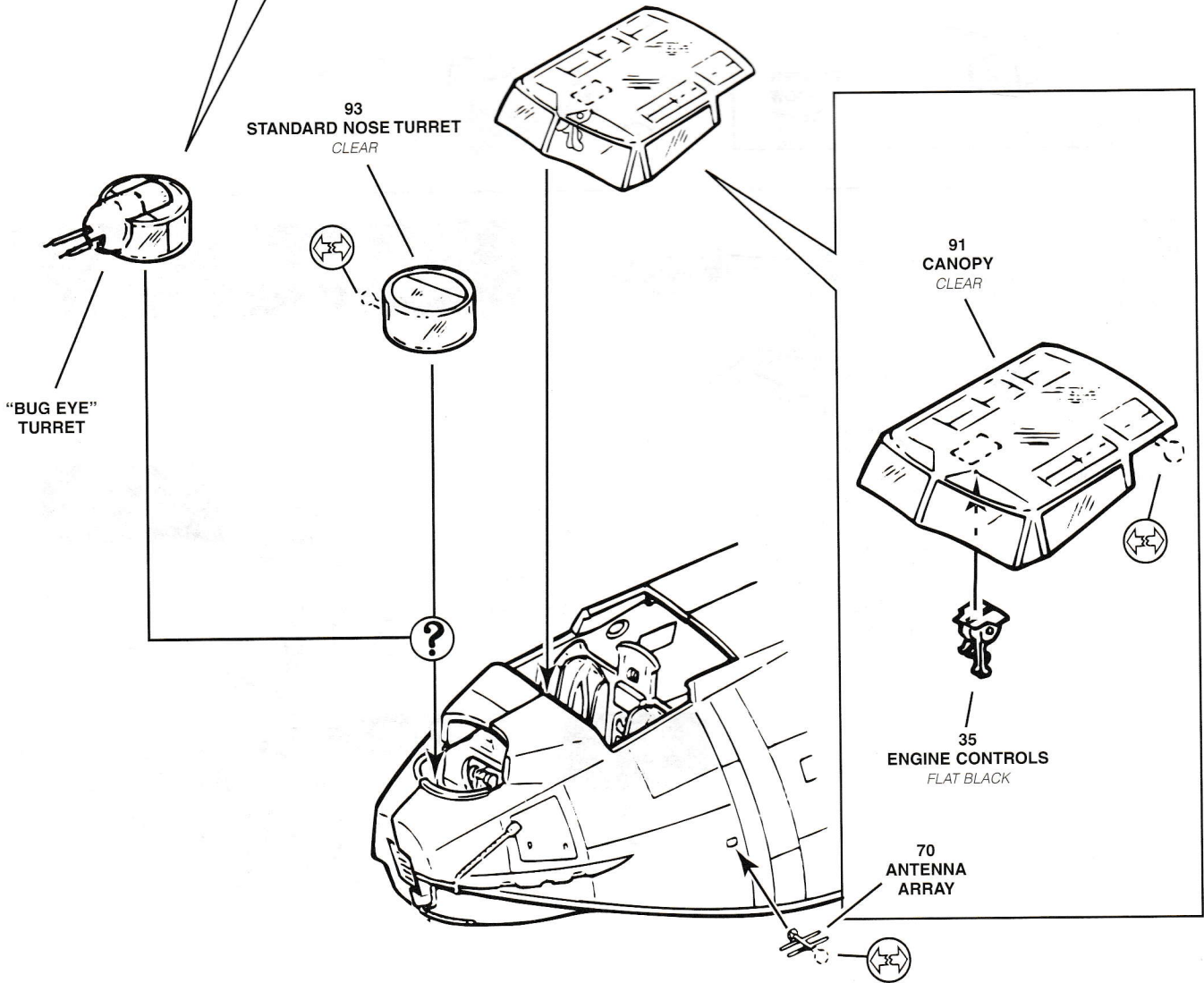

5

WING ASSEMBLY

A

NOTE: ASSEMBLY SEQUENCE

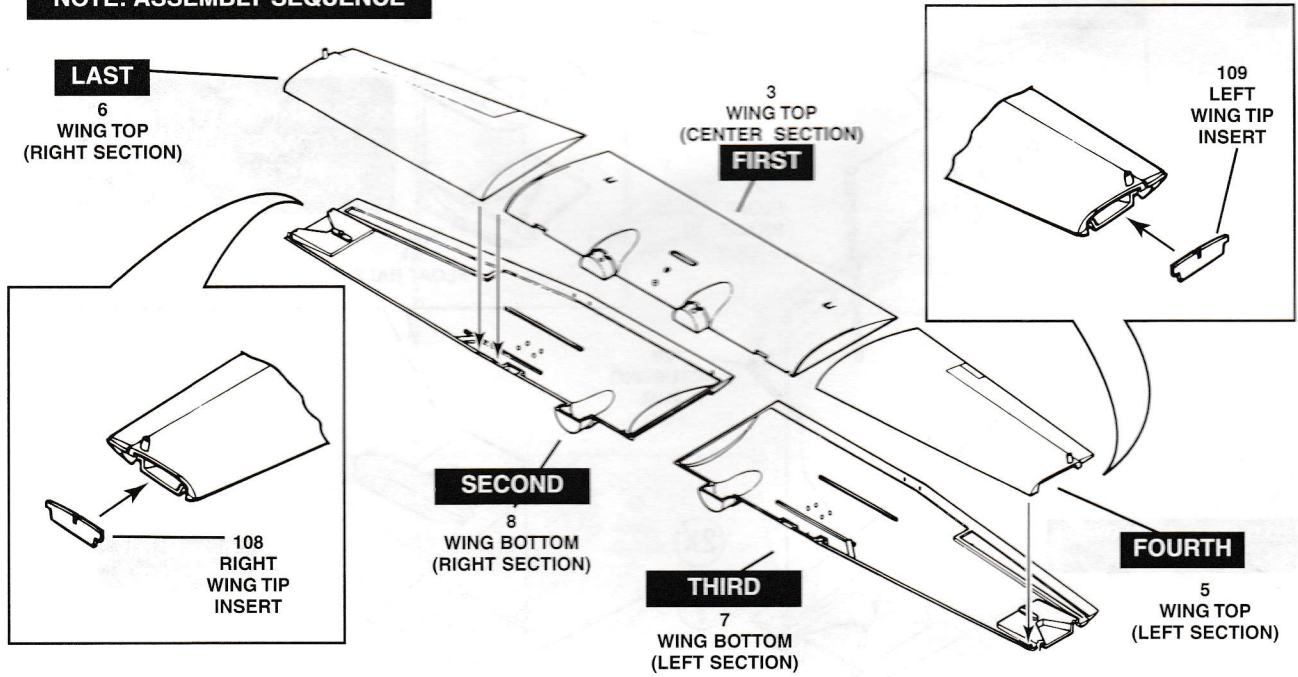

B

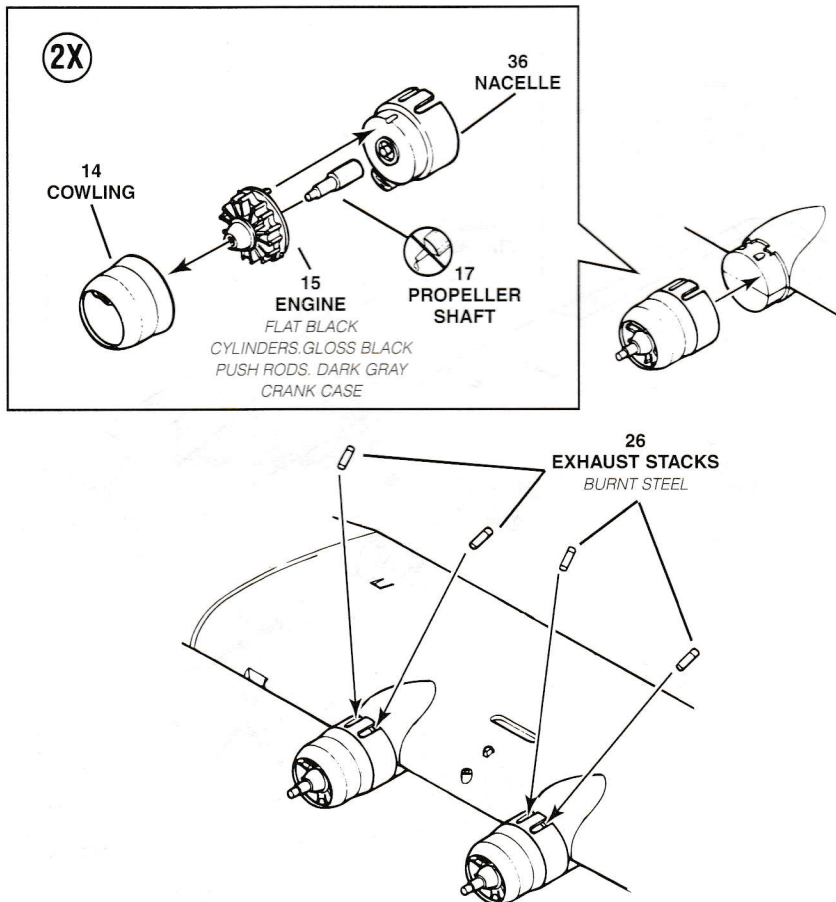

C

RIGHT WING ASSEMBLY

EXTENDED (DEPLOYED) POSITION

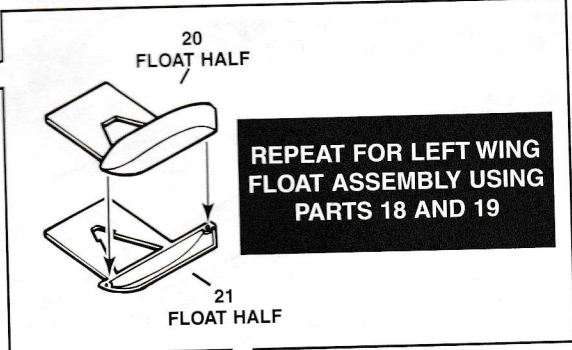
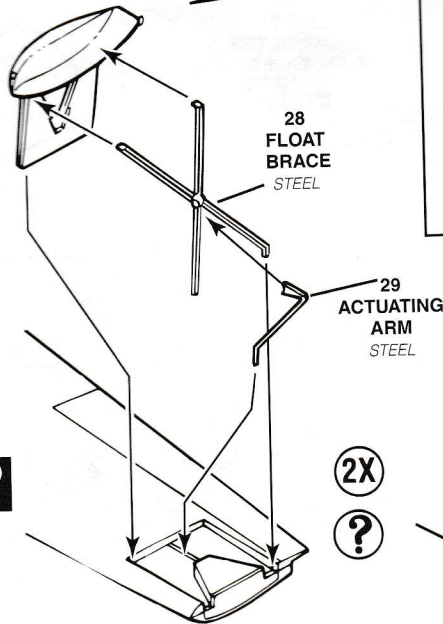

RETRACTED POSITION

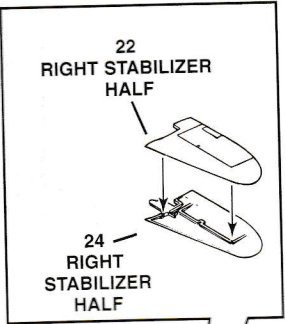
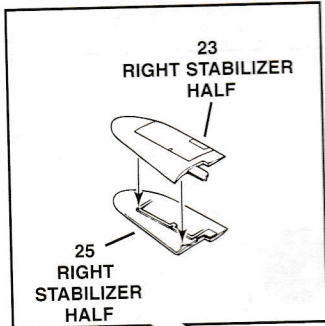
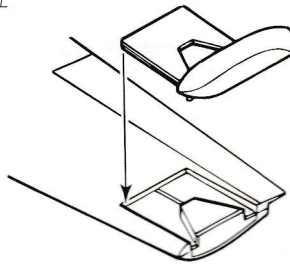

10 RIGHT REAR WING STRUT

12 RIGHT REAR WING STRUT

13 LEFT REAR WING STRUT

11 LEFT REAR WING STRUT

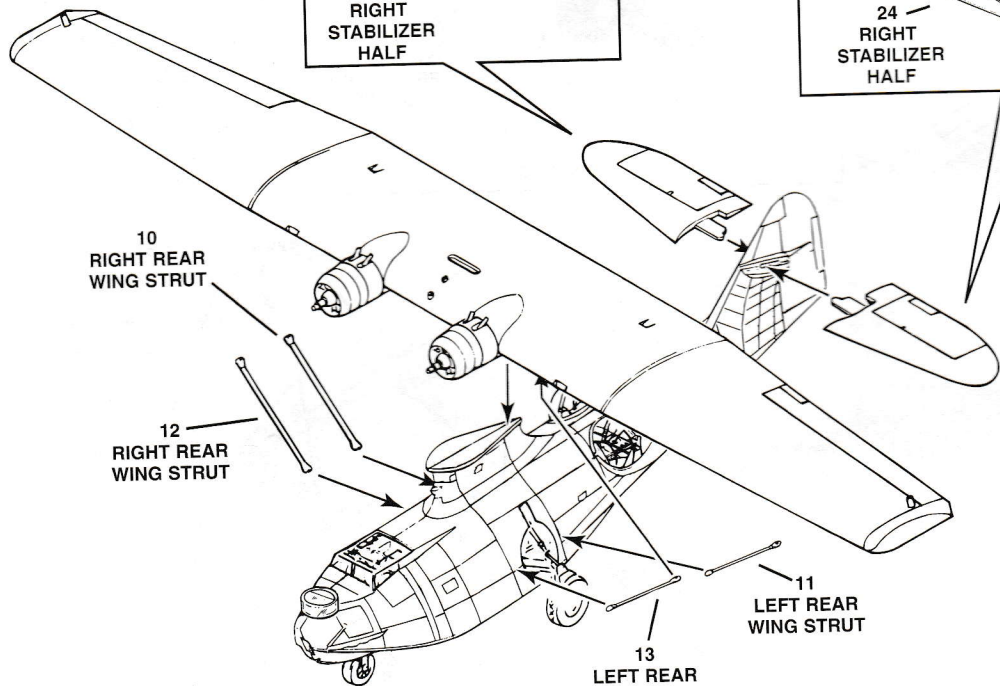

A

NOTE: DO NOT INCLUDE DEPTH BOMBS FOR RESCUE VERSION

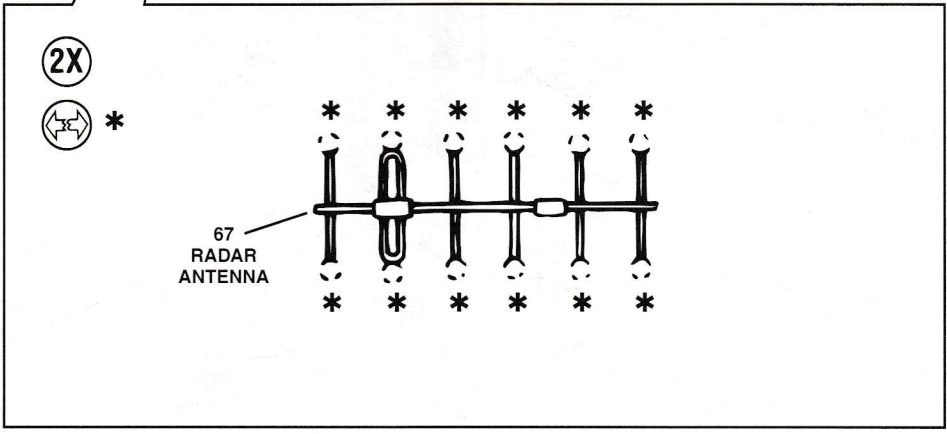
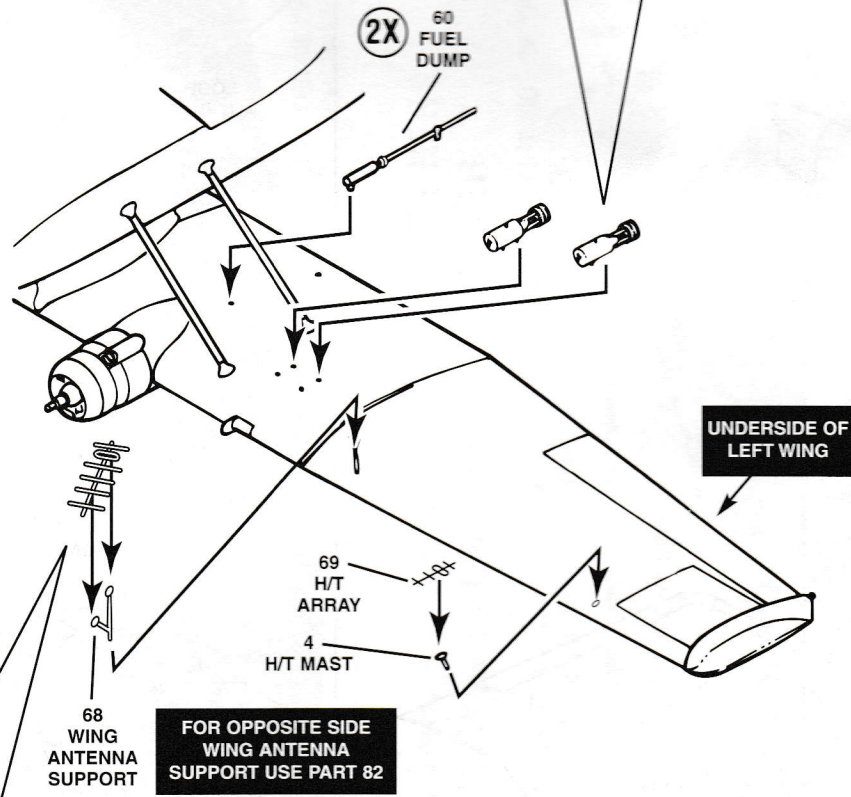
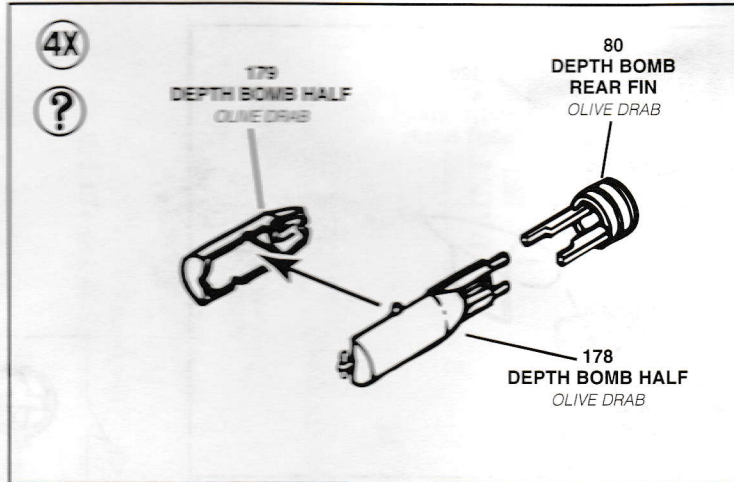

B

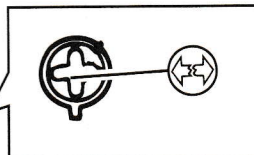
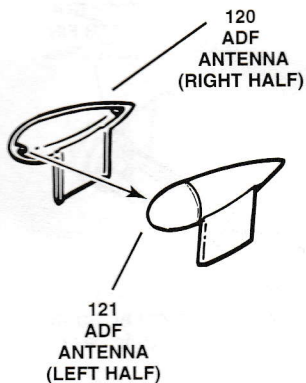

66
LOOP
ANTENNA

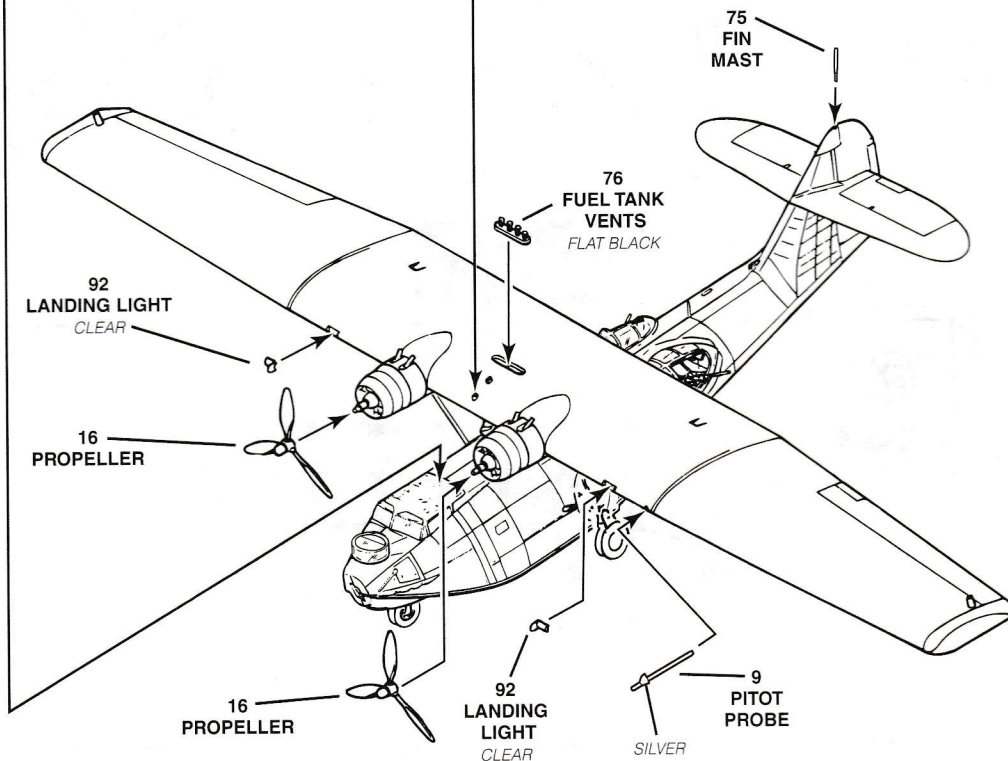

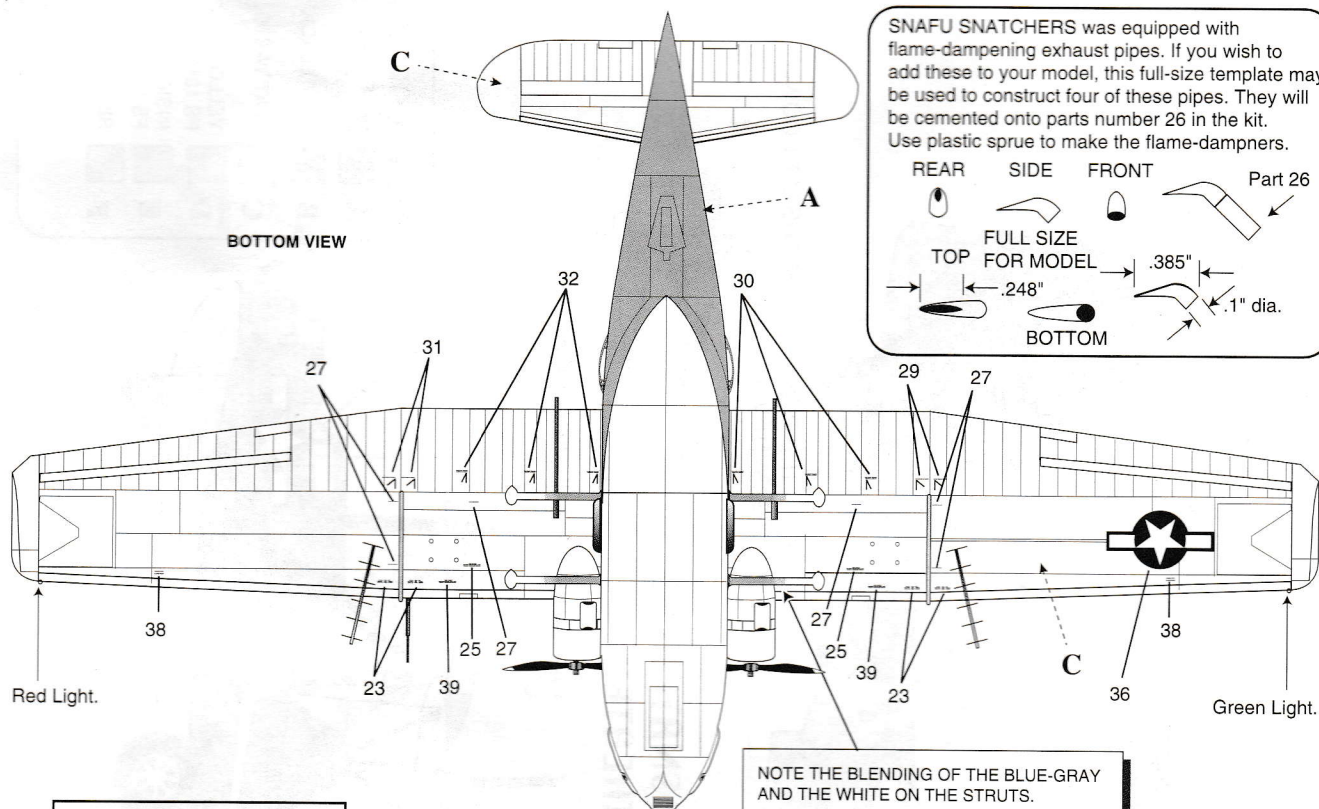

SNAFU SNATCHERS was equipped with flame-dampening exhaust pipes. If you wish to add these to your model, this full-size template may be used to construct four of these pipes. They will be cemented onto parts number 26 in the kit. Use plastic sprue to make the flame-dampners.

REAR SIDE FRONT Part 26

FULL SIZE TOP FOR MODEL

.248" .385" .1" dia.

BOTTOM

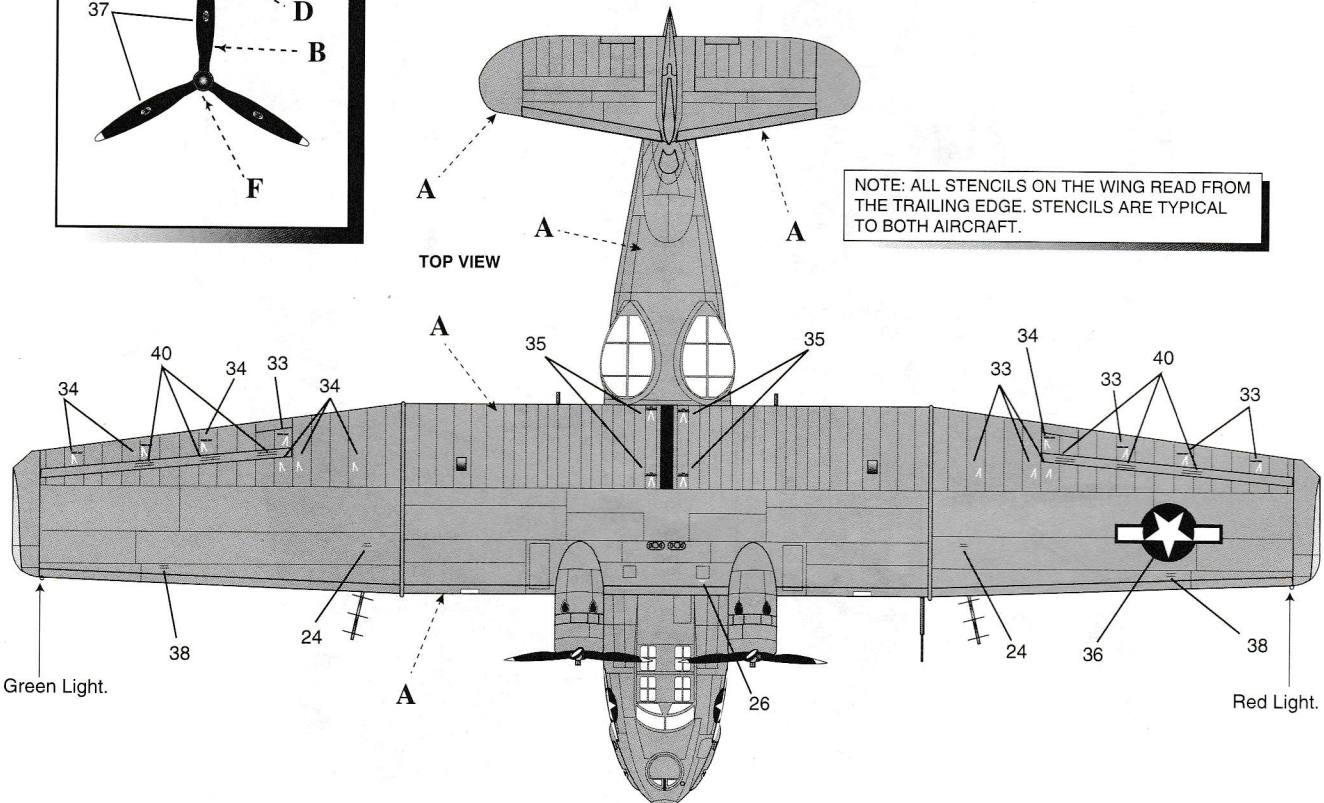
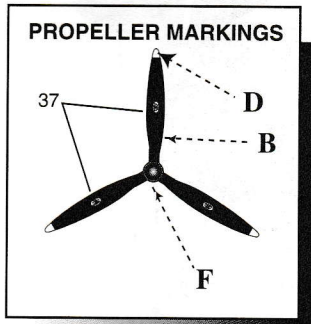

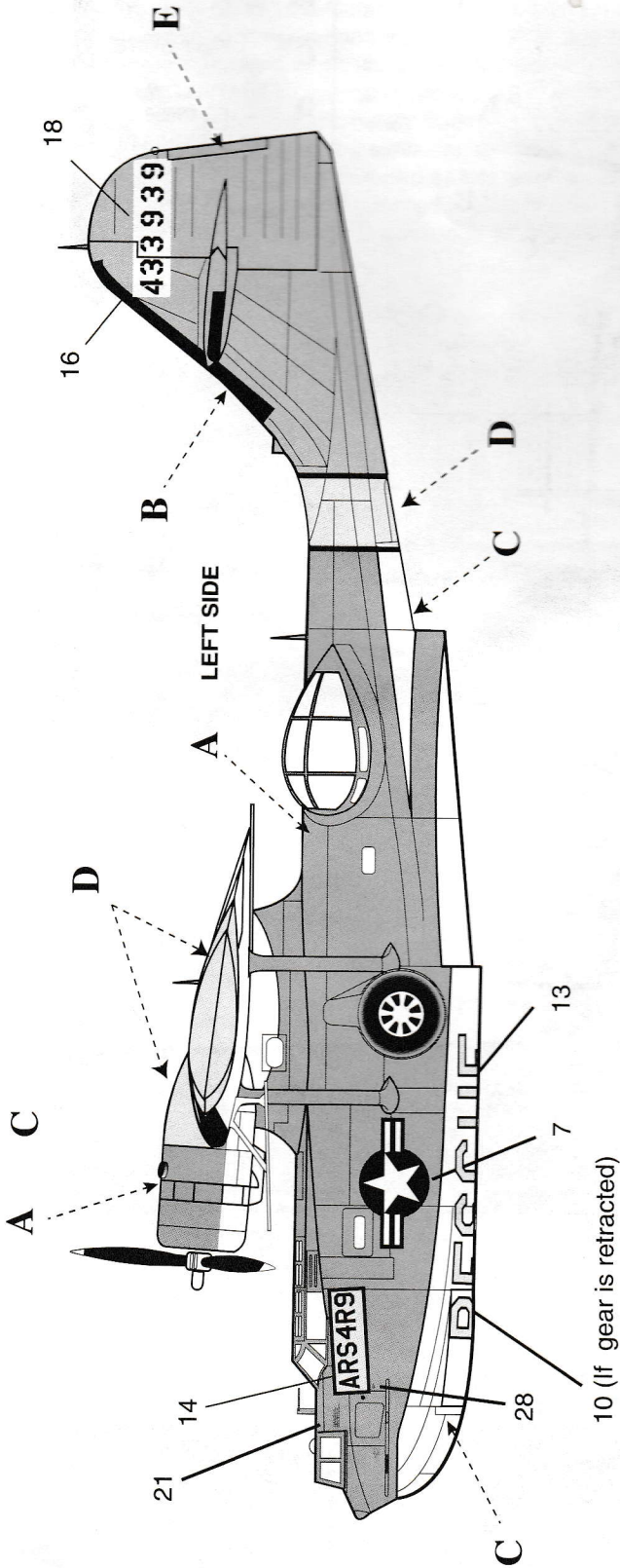



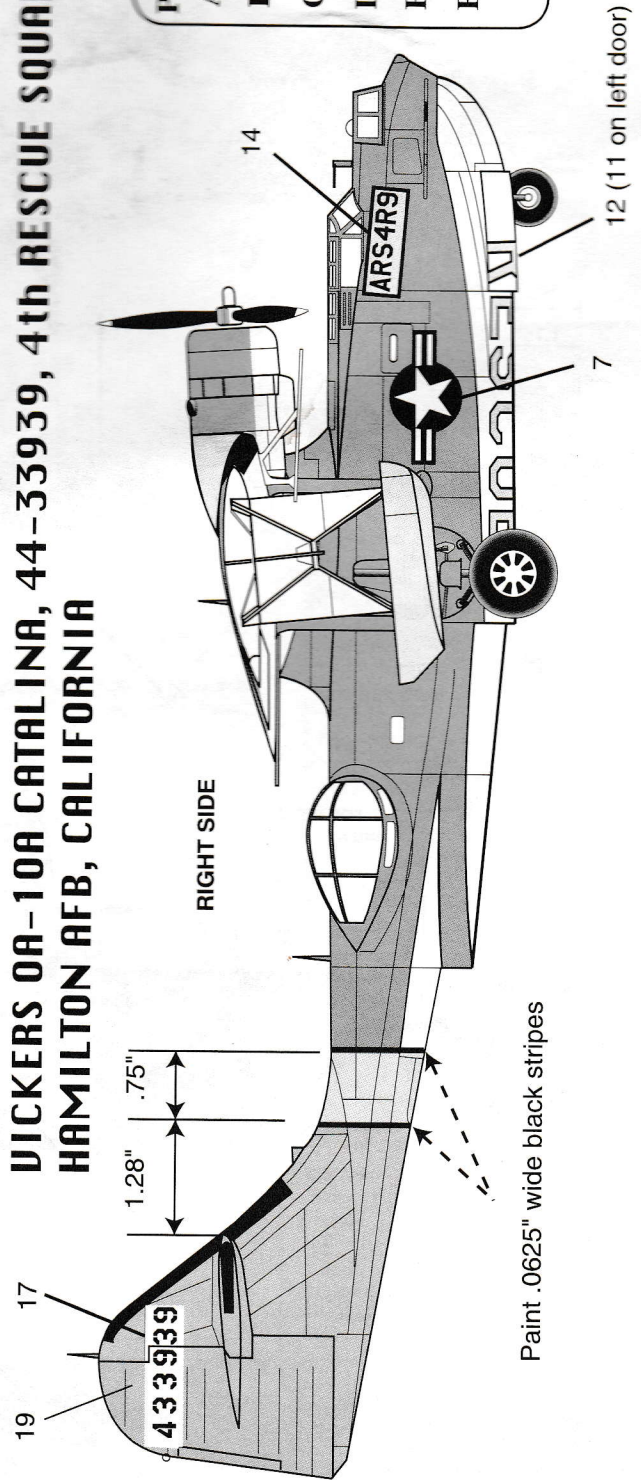



VICKERS OA-10A CATALINA, 44-33939, 4th RESCUE SQUADRON
HAMILTON AFB, CALIFORNIA



PAINT COLORS	
A	BLUE GRAY FS 36189
B	FLAT BLACK
C	FLAT WHITE
D	YELLOW FS 13538
E	INSIGNIA RED FS 11136
F	SILVER

PAINT COLORS

- A  BLUE GRAY
FS 35189
- B  FLAT BLACK
- C  FLAT WHITE
- D  YELLOW
FS 13538
- E  INSIGNIA RED
FS 11136
- F  SILVER

BOTTOM VIEW

NOTE: UPPER PAINT COLOR WRAPS AROUND EDGES OF FUSELAGE.

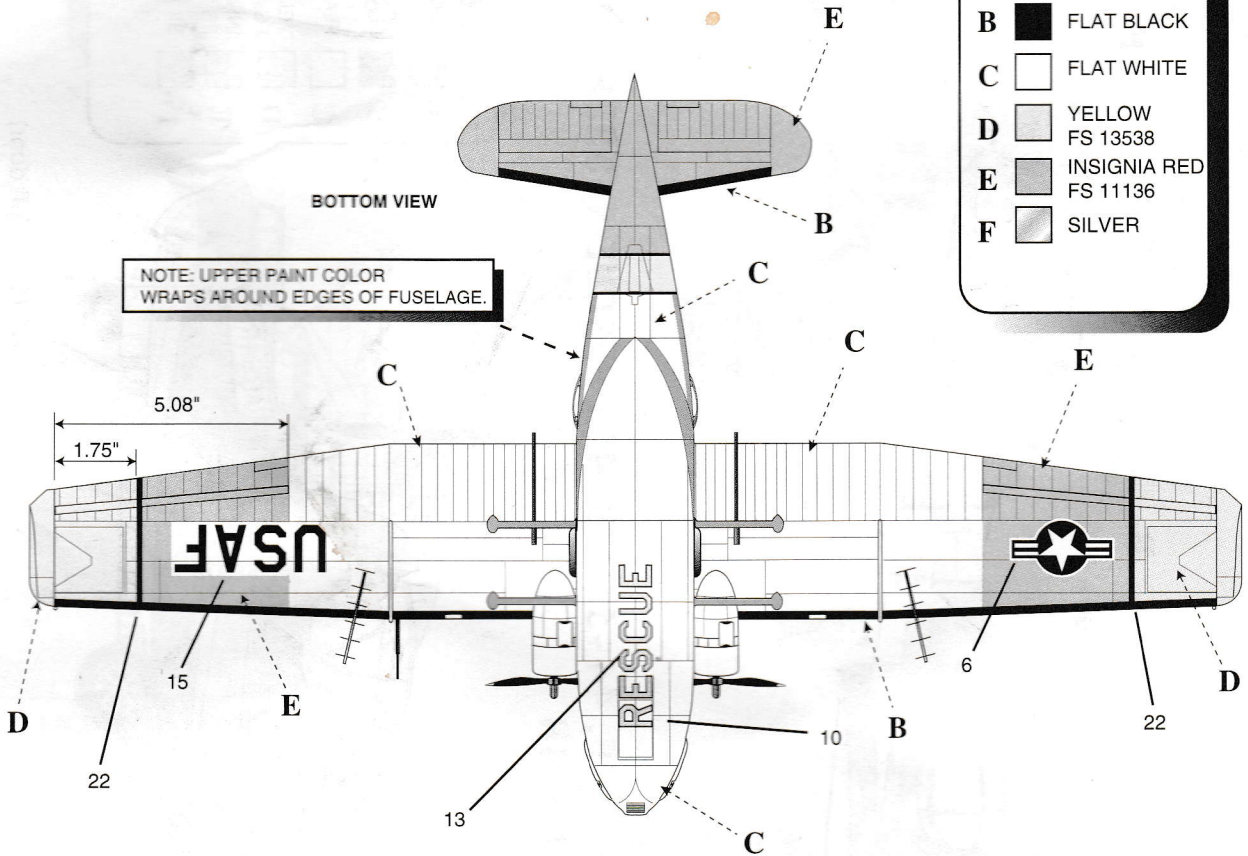

TOP VIEW

