



KIT 6865

8568500200

F9F-4/5 PANTHER

Grumman's F9F Panther has the distinction of being the first U. S. Navy jet fighter to see combat. Flying from aircraft carriers and land bases, Panthers were used in greater numbers and flew more missions than any other Navy fighter during the war in Korea. Armed with rockets, bombs, and four 20-mm cannons, they pounded communist positions over the entire Korean Peninsula. The U. S. Marine Corps also flew Panthers in Korea to attack enemy targets and to support United Nations forces on the ground. The versatile design of the Panther also permitted it to be used as a photographic reconnaissance aircraft as well. F9F-2P and F9F-5P versions had the gun armament in their noses replaced with vertical and oblique cameras. These aircraft took thousands of pictures of communist positions that were used for attack planning, and they also provided bomb damage assessment photographs to analyze the success of strikes by armed Panthers and other aircraft.

Your Revell-Monogram kit represents F9F-4/5 versions of the Panther, and markings are provided for two aircraft. One set of decals is for a F9F-5 Panther of the Golden Dragons of VF-192. This aircraft was used in the movie, "The Bridges of Toko-Ri" as the aircraft flown by William Holden's character, Commander Brubaker. The movie, which also starred Grace Kelly, Fredric March, and Mickey Rooney, was filmed aboard the USS ORISKANY, CV-34, which was named USS SAVO ISLAND for the movie. In an unusual event, the premier of the film took place on the aircraft carrier rather than in a theater. The second set of markings is provided for an F9F-4 Panther from Marine squadron VMF-334. The F9F-4 version of the Panther was externally identical to the F9F-5, but it was powered by an Allison J33-A-16 engine instead of the Pratt & Whitney J48-P-6 and J48-P-8 used in the F9F-5. Only 109 F9F-4s were produced, compared to 616 F9F-5s, and almost all were flown by Marine squadrons from land bases.

A special publication is also included with your kit. Entitled, "U. S. Navy Jet Fighters, Part 1, The Early Designs," it is the first of two such books that will cover U. S. Navy jet fighters and be released in Revell-Monogram scale model kits. This 48-page book provides a close-up look at the early jet fighters that operated from the U. S. Navy's aircraft carriers in the late 1940s and early 1950s. All of the designs that reached the flying stage are covered, and more extensive information is provided for those which entered operational service. A special section provides a detailed look at the F9F Panther, and it includes a look at the cockpit, power plant, armament, landing gear, and other features. Written by Bert Kinzey, well known for his Detail & Scale Series of publications, this book is sure to please all aviation enthusiasts and become a collector's item. Part 2, which will include the superersonic jet fighters which have served in the U. S. Navy, will be released in another Revell-Monogram kit in the near future.



* REPEAT SEVERAL TIMES
* A RÉPÉTER PLUSIEURS FOIS



* OPTIONAL PARTS
* PIÈCES EN OPTION



* DECAL
* DÉCAL COMAÑIE



* ALTERNATIVE ASSEMBLY
* ENSEMBLAGE ALTERNATIVE



* CEMENT TOGETHER
* A COLLER



* REMOVE AND THROW AWAY
* A RETIRER ET JETER



* DO NOT CEMENT
* NE PAS COLLER

READ THIS BEFORE YOU BEGIN

- Study the assembly drawings.
- Each plastic part is identified by a number.
- In the assembly drawings, some parts will be marked by a star (*) to indicate chrome plated plastic.
- For better paint and decal adhesion, wash the plastic parts in a mild detergent solution. Rinse and let air dry.
- Check the fit of each piece before cementing in place.
- Use only cement for polystyrene plastic.
- Scrape plating and paint from areas to be cemented.
- Allow paint to dry thoroughly before handling parts.
- Any unused parts may be discarded.

DECAL APPLICATION INSTRUCTIONS

1. Cut desired decal from sheet.
2. Dip decal in water for a few seconds.
3. Place wet decal on paper towel.
4. Wait until decal is movable on paper backing.
5. Place decal in position on model, face up and slide backing away.
6. Press out air bubbles with a soft damp cloth.
7. Minkiness that may appear is for better decal adhesion and will dry clear. Wipe away any excess adhesive.
8. Do not touch decal until fully dry.
9. Allow the decals 48 hours to dry before applying clear coat.

NOTE: Decals are compatible with setting solutions or solvents.

LIRE CE QUI SUIT AVANT DE COMMENCER

- Etudier les schémas de montage.
- Chaque pièce en plastique est identifiée par un numéro.
- Sur les schémas de montage, certaines pièces sont marquées d'une étoile (*) pour indiquer qu'elles sont en plastique chromé.
- Pour une meilleure prise de la peinture et des autocollants, laver les pièces en plastique avec une solution détergente peu concentrée. Les rincer et les laisser sécher à l'air.
- Vérifier que chaque pièce s'ajuste bien avant de la coller en place.
- N'utiliser que de la colle pour polystyrène.
- Gratifier les parties à coller pour enlever le chrome et la peinture.
- Laisser la peinture bien sécher avant de manipuler les pièces.
- Toute pièce inutilisée peut être jetée.

DIRECTIVES D'APPLICATION DES AUTOCOLLANTS

1. Découper l'autocollant désiré de la feuille.
2. Tremper l'autocollant dans de l'eau pendant quelques secondes.
3. Placer l'autocollant mouillé sur une serviette en papier.
4. Attendez que l'autocollant puisse être déplacé sur son support en papier.
5. Mettre l'autocollant en position sur le modèle face sur le dessus et faire glisser le support pour l'enlever.
6. Appuyer avec un chiffon doux humide pour éliminer les bulles d'air.
7. La substance laiteuse qui peut apparaître est destinée à améliorer l'adhésion de l'autocollant et devient incolore au séchage. Essuyer pour enlever tout excédent d'adhésif.
8. Ne pas toucher l'autocollant tant qu'il n'est pas bien sec.
9. Laisser l'autocollant sécher pendant 48 heures avant d'appliquer une couche transparente.

REMARQUE: Les autocollants sont compatibles avec les solutions de fixation ou les solvants.

This optional paint guide is provided if you choose to detail paint your model.

Ce guide de peinture vous sera fourni si vous choisissez de peindre votre modèle en détail.

Aluminum	Aluminum
Bright Silver	Argent clair
Chromate Green	Vert chromate
Dark Tan	Havane foncé
Flat Black	Noir mar
Flesh	Chair
Gloss Sea Blue FS 15042	Bleu de mer
Insignia Red FS 11336	Bleu emblème
Khaki	Brun clair
Olive Drab	Olivet
Red	Rouge
Rubber	Caoutchouc
Satin Black	Noir satiné
Satin White	Blanc satiné
Silver	Argent
Steel	Acier
Transparent Green	Vert transparent

If you have any questions or comments, call our hotline at: **(800) 833-3570**
or, please write to:

Revell-Monogram Consumer Service Department, 8601 Waukegan Road, Morton Grove, Illinois 60053
Be sure to include the plan number (85686500200), part number, description, your return address and phone number.

Visit our website: www.revell-monogram.com

MAIN AIRFRAME ASSEMBLY

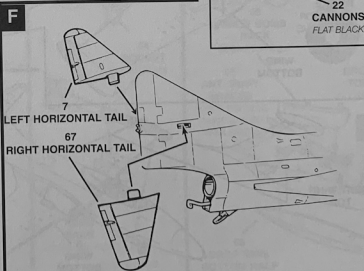
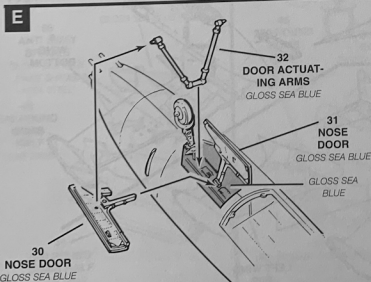
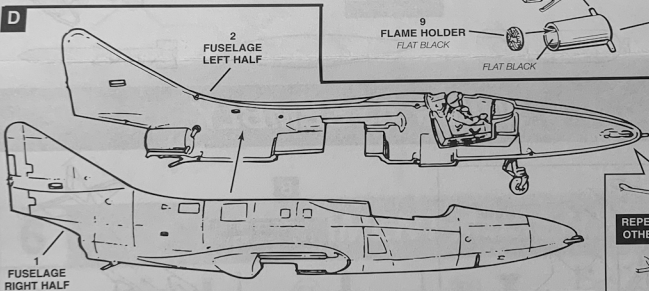
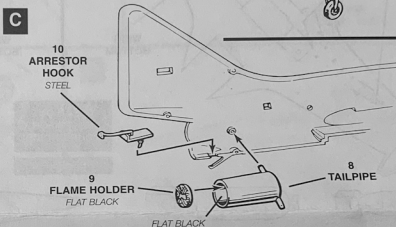
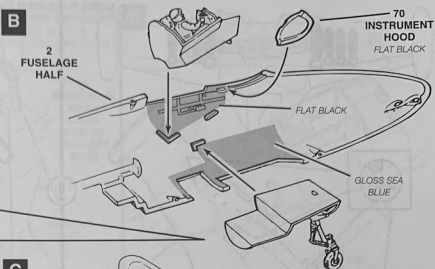
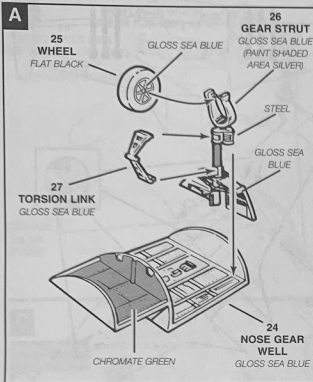

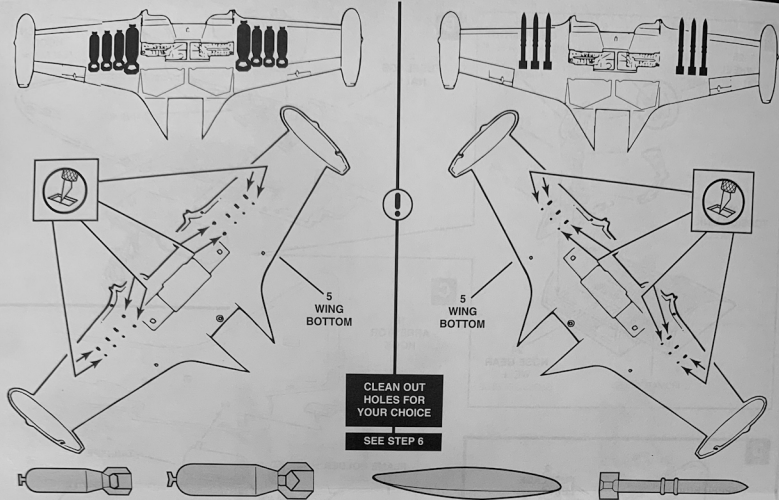
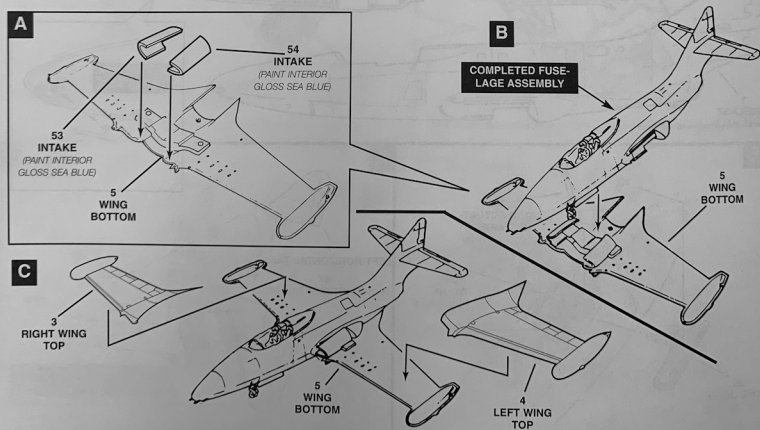
3**ARMAMENT OPTIONS ASSEMBLY****4****WING ASSEMBLY**

5

MAIN LANDING GEAR ASSEMBLY

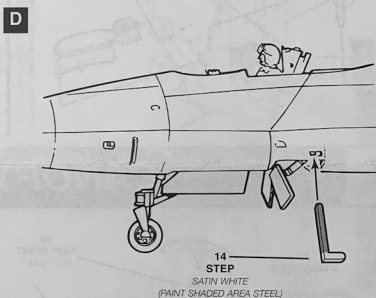
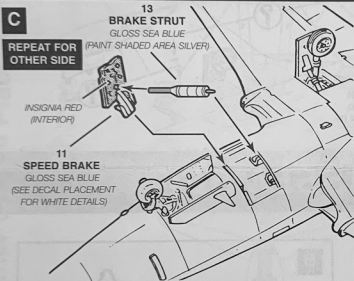
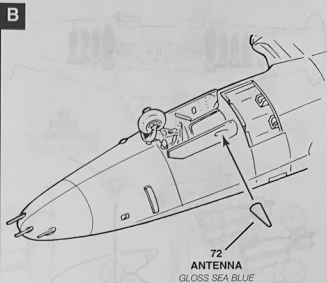
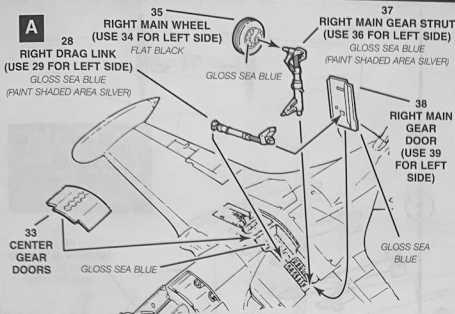

6

ARMAMENT ASSEMBLY

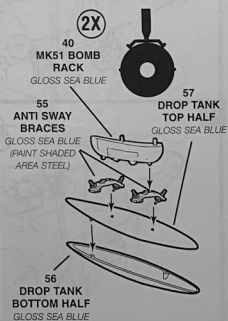
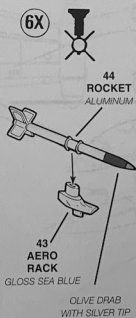
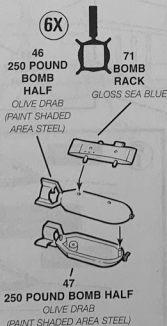
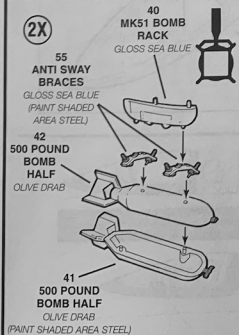

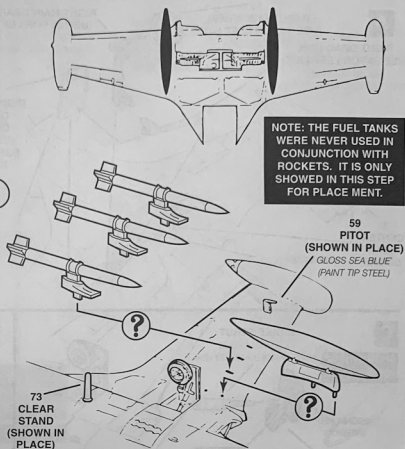
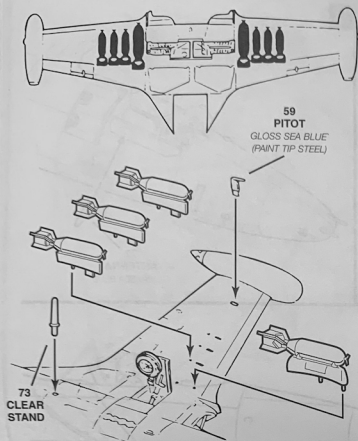
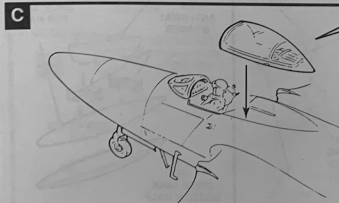
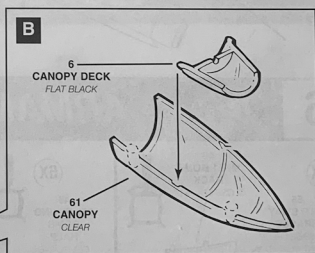
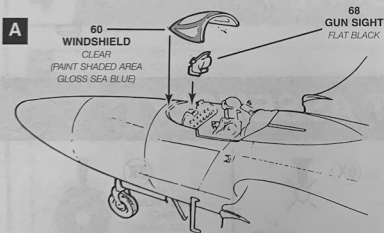
6**ARMAMENT ASSEMBLY** CONTINUED**7****CANOPY ASSEMBLY****OPEN**

**NOTE: PAINT DARK SHADED AREAS GLOSS SEA BLUE,
PAINT LIGHT SHADED AREA SATIN WHITE**

CLOSED

F9F-5 Panther Stencil Placement

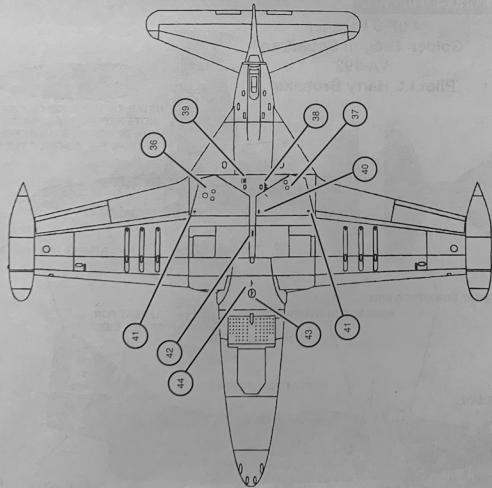

❓ If you are building the VA-192 version, use decal 23 instead of using decal 36.

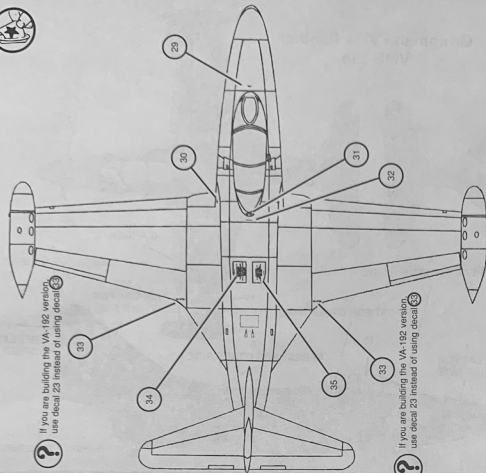

❓ If you are building the VA-192 version, use decal 23 instead of using decal 33.

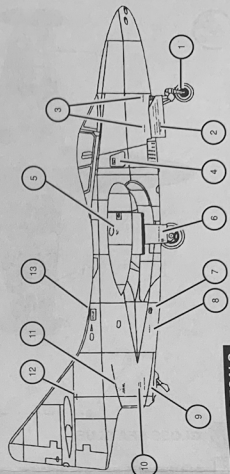
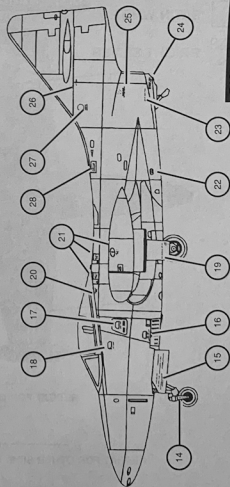

DISREGARD ANY UNUSED DECALS

