

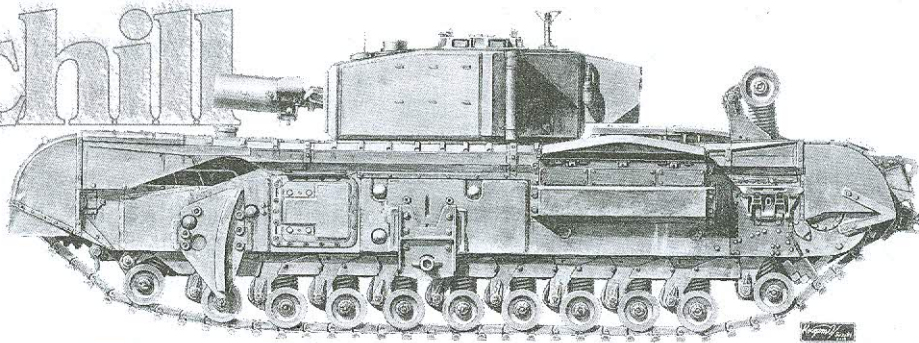

Churchill

Mk III



Armoured Vehicle Royal Engineers

**SPECIAL THANKS: Ossie Orsourn

The raid on Dieppe, known as Operation Jubilee, was taken place in August 1942. The aims were to seize and hold a major port for a short period and examine the German reaction. Strategically, this raid was also to mitigate the pressure suffered by the Soviet Army in the Eastern Front.

A force of over 6000 infantrymen, predominantly Canadian, with supports from large British naval and Allied air force contingents, participated in this raid. Among them the Canadian Calgary Regiment left UK with some 29 Churchill tanks, 27 made it ashore. Yet, without appropriate supports from engineer vehicles, those tanks were quickly straggled by obstacles on the beach, rendering insufficient fire support to the infantry troops. No major objectives of the raid were accomplished, Operation Jubilee ended up as a catastrophe.

The experience at Dieppe, however, did influence Allied preparations for the Second front: Operation Overload. To avoid troops and vehicles being trapped on the shore by enemy fire and fortified obstacles, Chief of the Imperial General Staff, Field Marshal Sir Alan Brooke, approved development on a variety of supportive engineer vehicles proposed by Major General Percy Hobart in March 1943. Those engineer vehicles aimed to clear minefield on the first wave, and provide suppressing fire while leading the troop through obstacles.

The Churchill tank was chosen as the platform due to its thick armour. 6-pounder guns replaced 290 mm mortars which became the concrete bunker buster. Such platform is known as Churchill AVRE.

Up to Operation Overload, there were some 180 AVREs converted from Churchill IIIs and IVs. All those AVREs were under command of Major General Hobart's specialised 79th Armoured Division. They were used in Normandy invasion, saw service in Gold, Juno and Sword Beaches.

1942年8月、ジュビリー作戦として知られるディエップ上陸作戦が実施された。その目的は、短期間に主要な港を制圧することとドイツ軍の反撃力を試すことにあったが、戦略的には、第二戦線を形成することによって、東部戦線で激しい戦闘を行っているソ連軍を援護するというねらいがあった。イギリス海軍と連合軍航空機の援護を受けた、カナダ軍兵士を主力とする6000名以上の歩兵が作戦に参加した。カナダ・カルガリー連隊は29輛のチャーチル戦車とともにイギリスを出兵し、27輛が海岸に上陸した。しかし、これらのチャーチル戦車は、工兵車輛による効果的な支援が受けられなかったために、たちまち海岸の障害物に阻まれ、歩兵を満足に援護することもできなかった。目標であった要地の制圧も成し得ず、ジュビリー作戦は惨憺たる結果に終わったのである。

しかしながらディエップでの苦い教訓は、次のオーバーロード作戦の準備に多大な影響を及ぼすこととなった。上陸した海岸で、敵の砲火や堅固な障害物によって兵士や車輛が身動き出来なくなるような事態を防ぐため、英陸軍参謀総長アラン・ブルック元帥は、1943年3月、パーシー・ホバート少将より提案された、各種支援用工兵戦闘車輛の開発計画を承認した。これらの工兵戦闘車輛は、地雷除去や部隊の障害物突破の際の先導・火力支援等が任務であった。

チャーチル戦車は強固な装甲によりベース車輛として、うってつけであった。コンクリート障害物破壊のために、6ポンド砲にかわって、290mm臼砲が搭載された。これらの車輛は、チャーチルAVRE（工兵戦闘車）車輛は、チャーチルAVRE（工兵戦闘車）と呼ばれている。

オーバーロード作戦までに、チャーチルMk. III、MK. IVから180輛がAVREに改造された。これらすべてのAVREは、ホバート少将指揮下の第79装甲師団に配備され、ノルマンディ上陸作戦時の、ゴールド、ジュノー、上陸作戦時の、ゴールド、ジュノー、ソードといった海岸でドイツ軍の防御線突破に活躍したのである。

1942年8月,為了緩解德蘇戰線上蘇聯所面臨的嚴峻壓力,以加拿大陸軍為主的地面部隊,配合著皇家海空軍,在法國臨近英吉利海峽的海港第厄普(Dieppe)進行了一次試探性的登陸,由於行動的作為在一開始就是被設定是"局部"的,因此參與的登陸部隊規模尚不及萬人,其中包括了一支由29輛邱吉爾步兵戰車所組成的卡爾加里戰車團(The Calgary Regiment),在沒有工兵車輛的支援下,這二十幾輛戰車在登陸後很快的便受困於海岸上各種障礙物間,使得進入第厄普市鎮的步兵部隊無法獲得足夠的地面火力支援,在作戰目標無法達成的情況下,這次作戰行動一如預料的以失敗告終。

這次失敗的登陸行動為爾後的開闢第二戰場的行動取得了許多寶貴的經驗,為避免登陸部隊一上岸便被障礙物及火網困在灘頭之上,1943年3月英國參謀總長批准了陸軍少將霍伯特(Percy Hobart)的建議,計畫研製各式特種工兵支援車輛,以俾使在登陸之時能率先清除雷區,帶領部隊通過障礙物並適時壓制德軍火力,邱吉爾步兵戰車由於其厚重的裝甲,被挑選為這些特種車輛共通的載台;原本搭載的六磅砲被改為290mm口徑的迫擊砲,使之成為攻擊德軍混凝土掩體的利器,這樣的車輛被稱為:邱吉爾皇家工程戰鬥車輛(Churchill AVRE)。

至諾曼地登陸登陸之前,共有180輛邱吉爾Mk III與Mk IV型被改裝為AVRE,全部被配屬在由霍伯特擔任師長的英國第79裝甲師之中,在黃金海灘、朱諾海灘與寶劍海灘中都可以看見AVRE活躍的身影。

Illustration:圖示說明



Method For Applying Decals:

1. Clean Model Surface With Wet Cloth.
2. Cut Out Of Decal Sheet And Dip Them In Water For 15 Seconds.
3. Place it on proper position on model.
4. Slide off base paper leaving decals On Model With Wet Finger Tip.
5. Move Decals To Exact Position, Push Out Excess Water Under Decal With Soft Cotton Cloth.
6. When Decals Get Dry Then Complete.

水貼紙使用說明:

1. 將模型表面擦乾淨
2. 將貼紙剪下泡入清水中約15秒
3. 將泡濕之貼紙取出置於欲貼處旁
4. 用指尖輕推貼紙表面使其滑出底紙
5. 將貼紙調整至適當位置並輕擦拭水份
6. 待其自然乾燥後即完成

Color list: 塗料表

Color	Brand	Gunze Sangyo			Humbrol	Revell	Life Color
		Hobby Color	Mr. Color	Mr. Color Spray			
Khaki green	卡其綠	H-80	C-54				
Sandy Yellow	沙黃	H-66	C-119		168	UA020	
Steel	黑鐵	H-18	C-28	J-28	53	91	LC76
Tire black	輪胎黑	H-77	C-33+C-62		85	302	LC02
Red	紅	H-3	C-3	J-3	19	31	LC56
Flat white	消光白	H-11	C-62	J-62	34	05	LC01
Red brown	紅褐	H-47	C-41	J-44	160	383	UA085
Brass	黃銅	H-9	C-9	J-9	54	92	LC75
Wood brown	木棕	H-37	C-43	J-43	10	81	UA085/ UA125
Olive drab(2)	橄欖綠	H-78	C-38	J-38	66	46	UA106

1

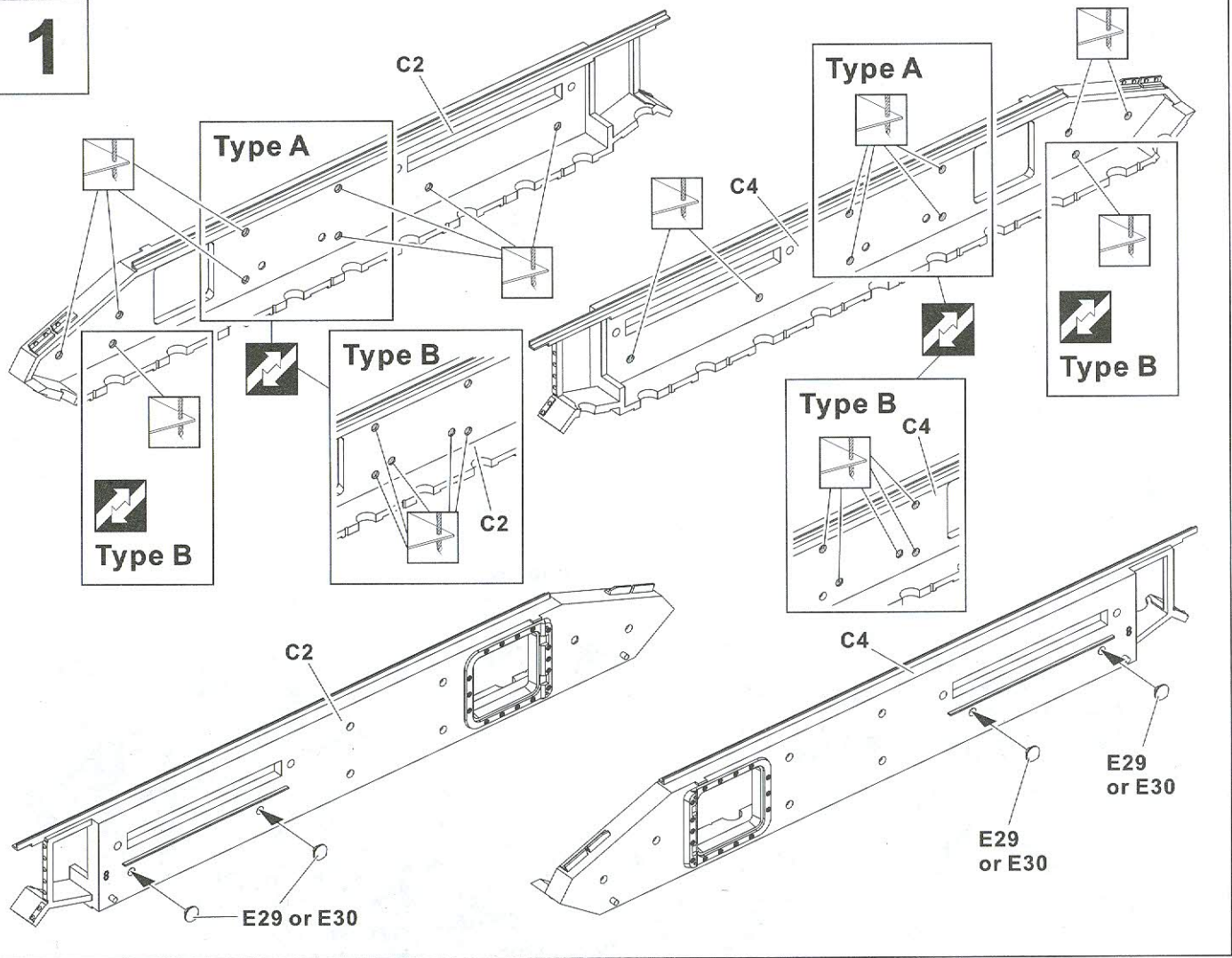

2

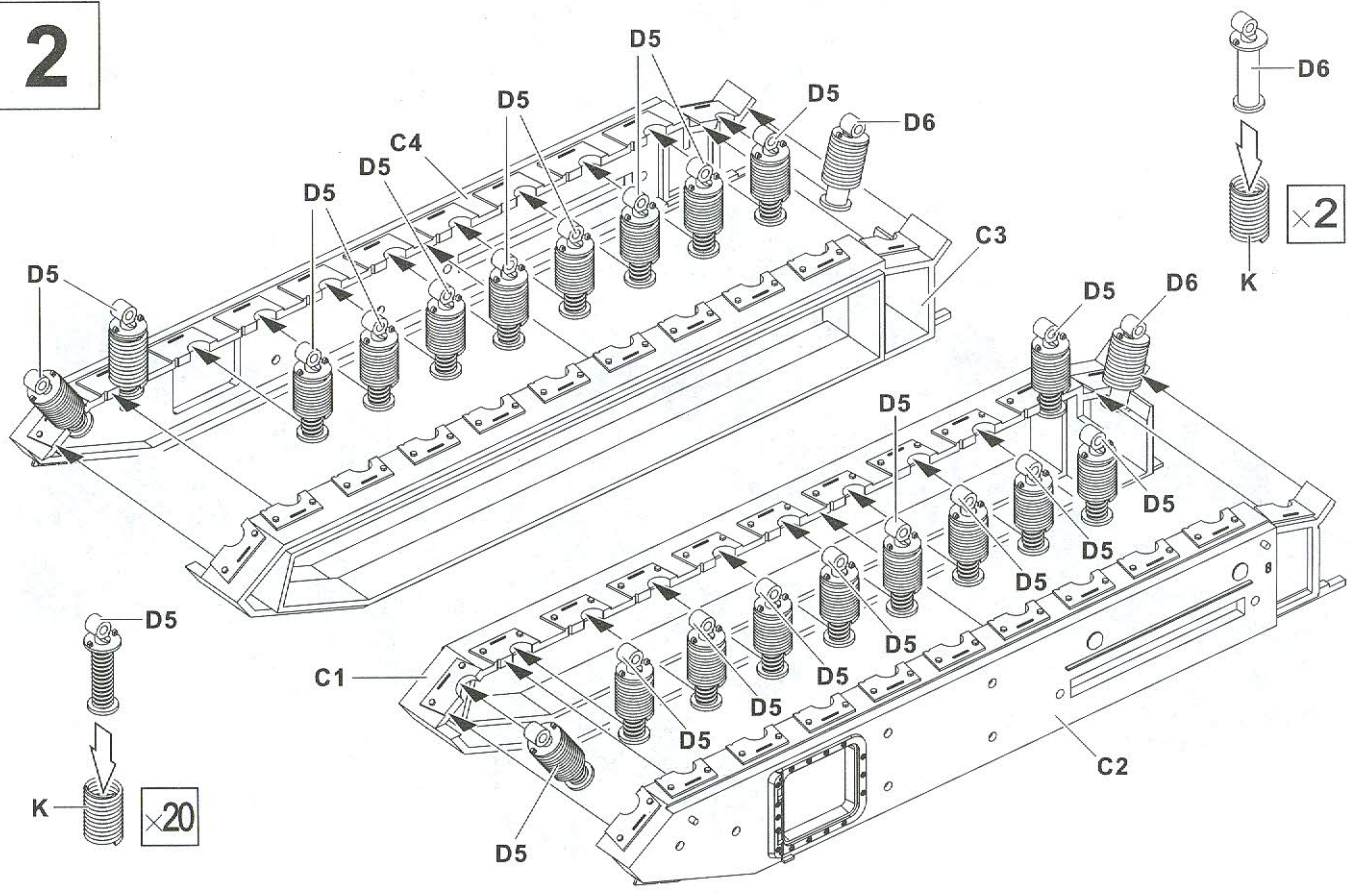

3

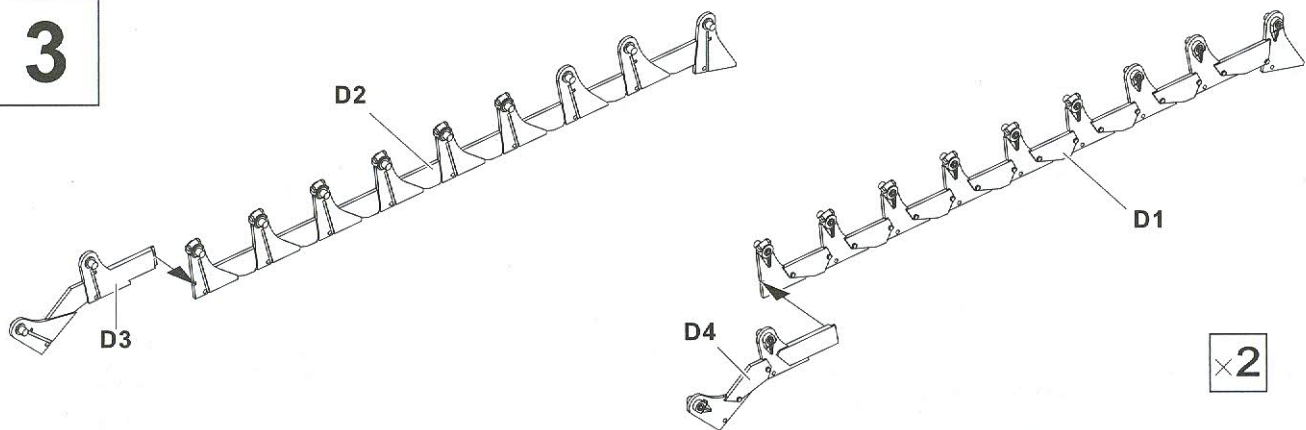

4

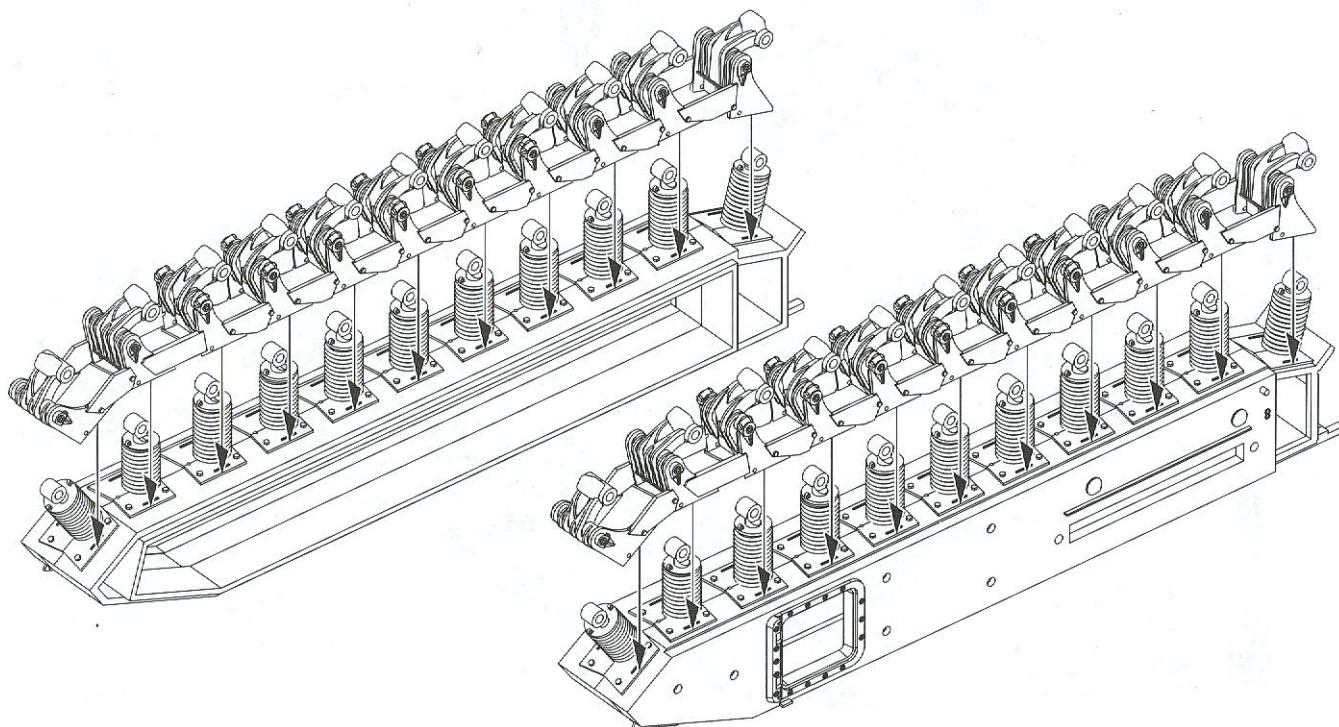
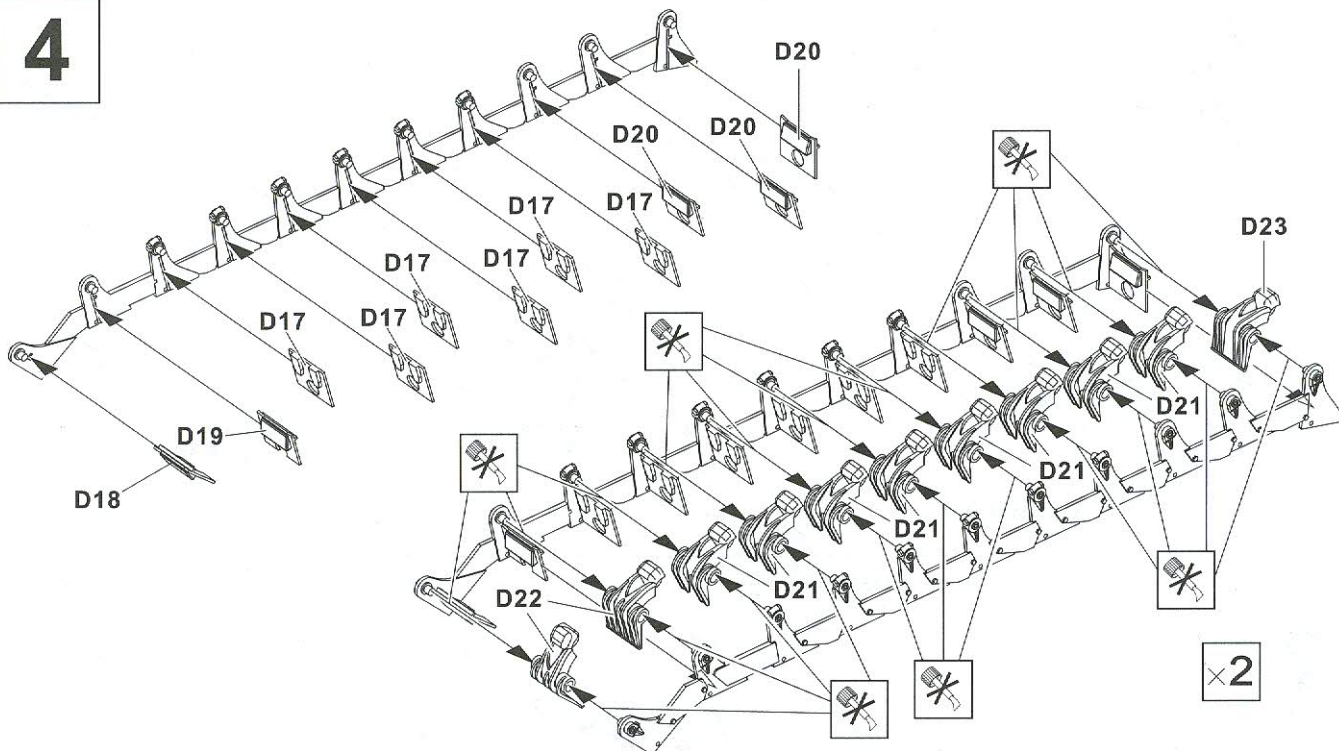

5

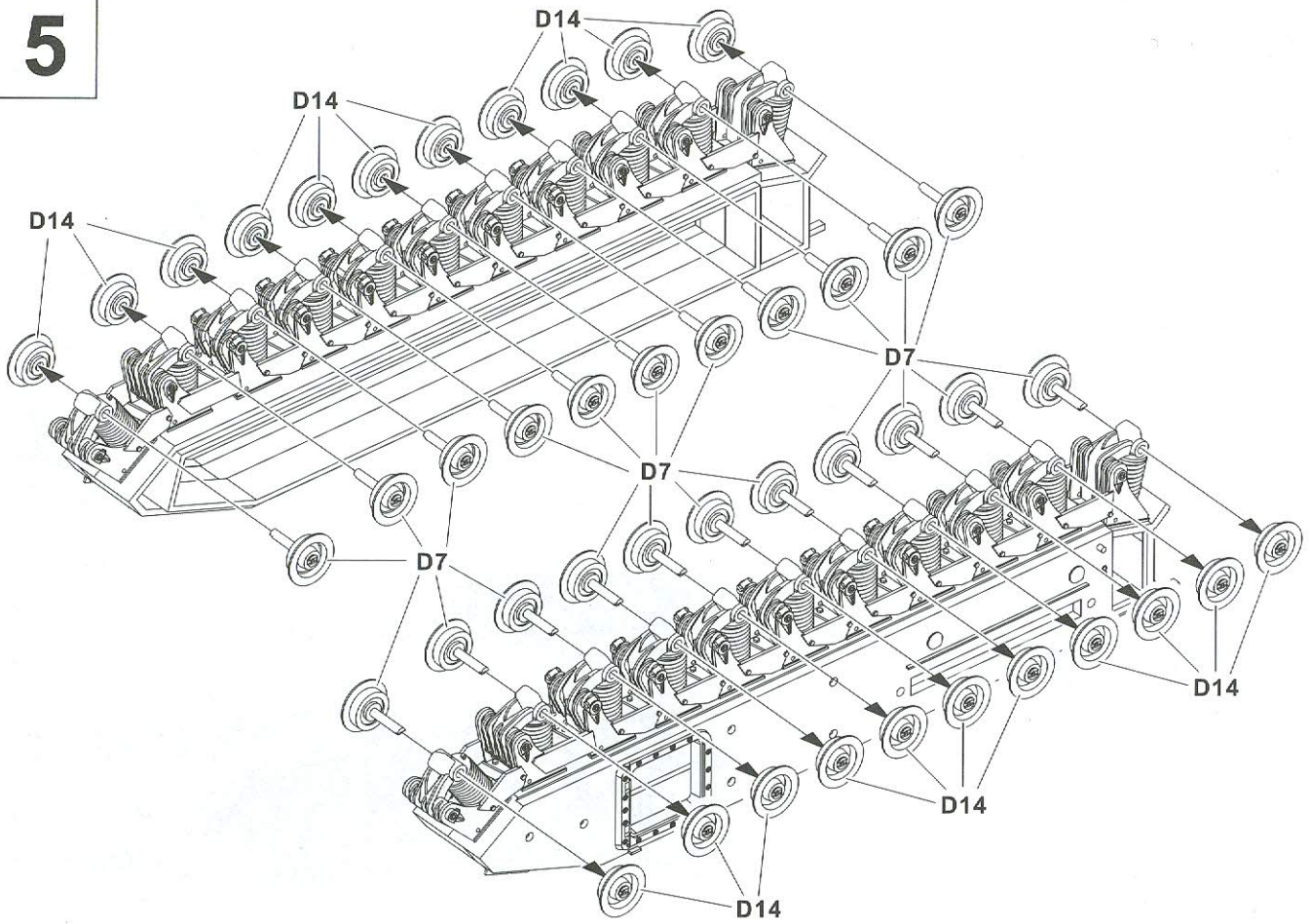

6

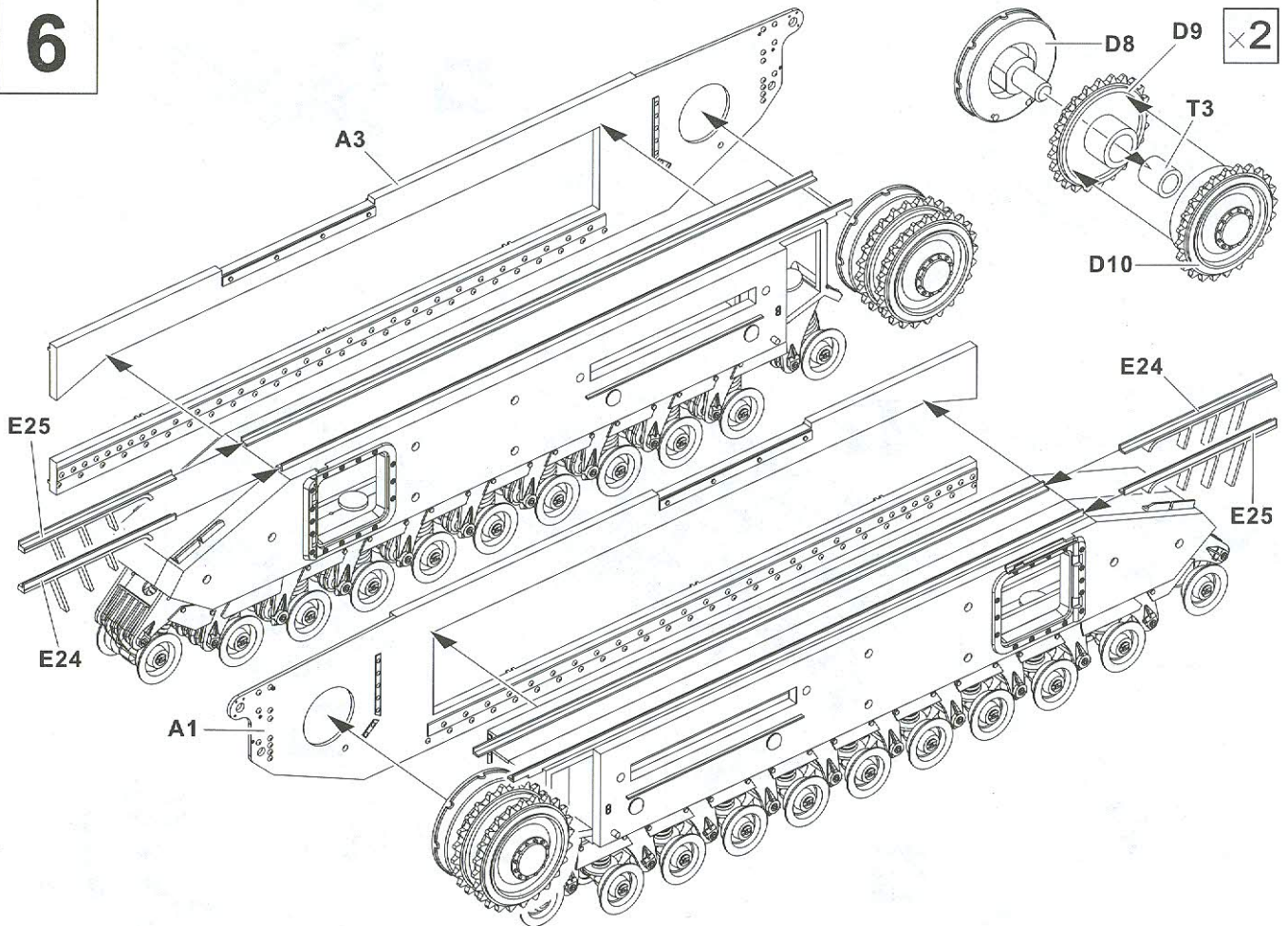

7

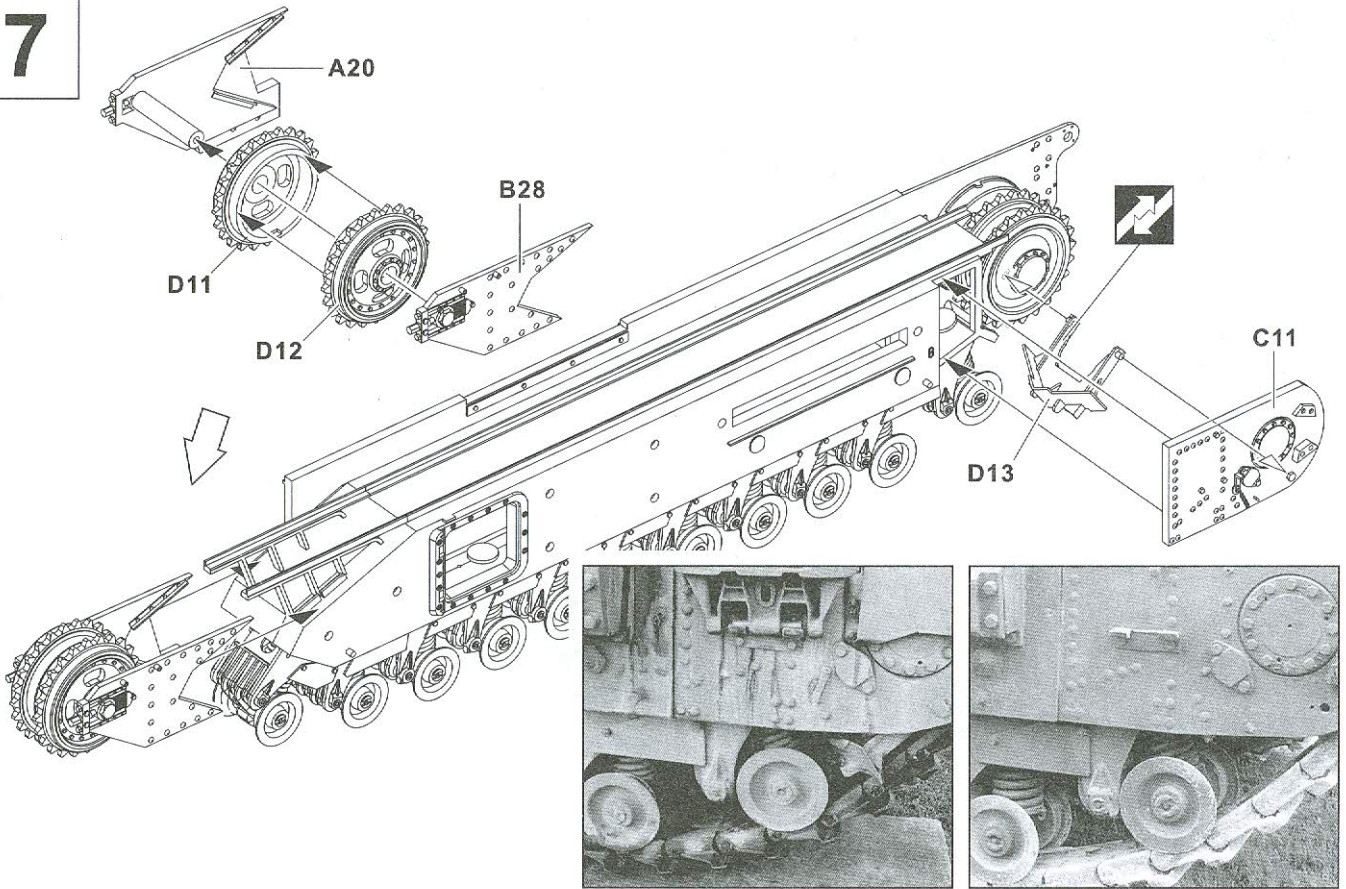

8

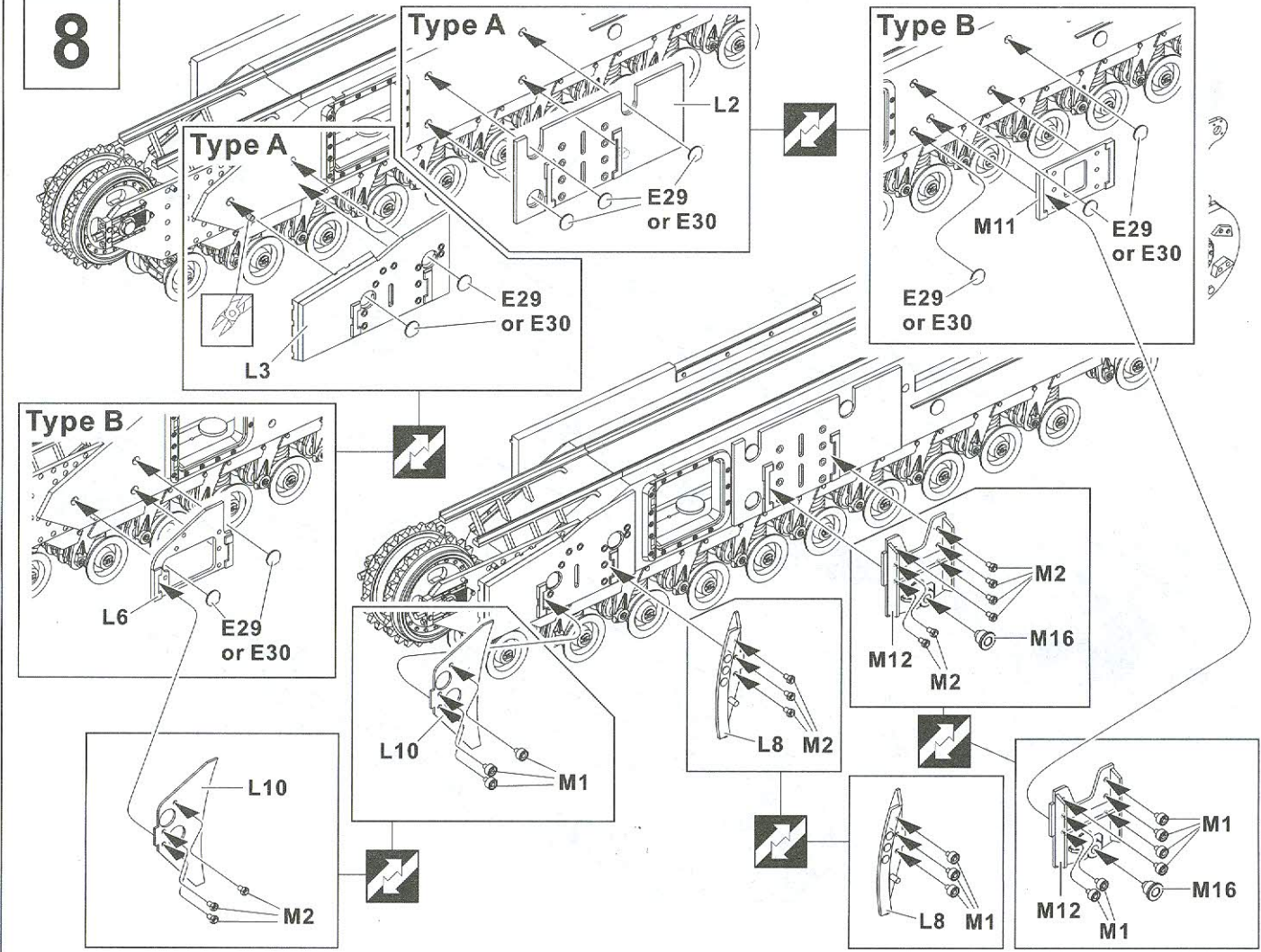

9

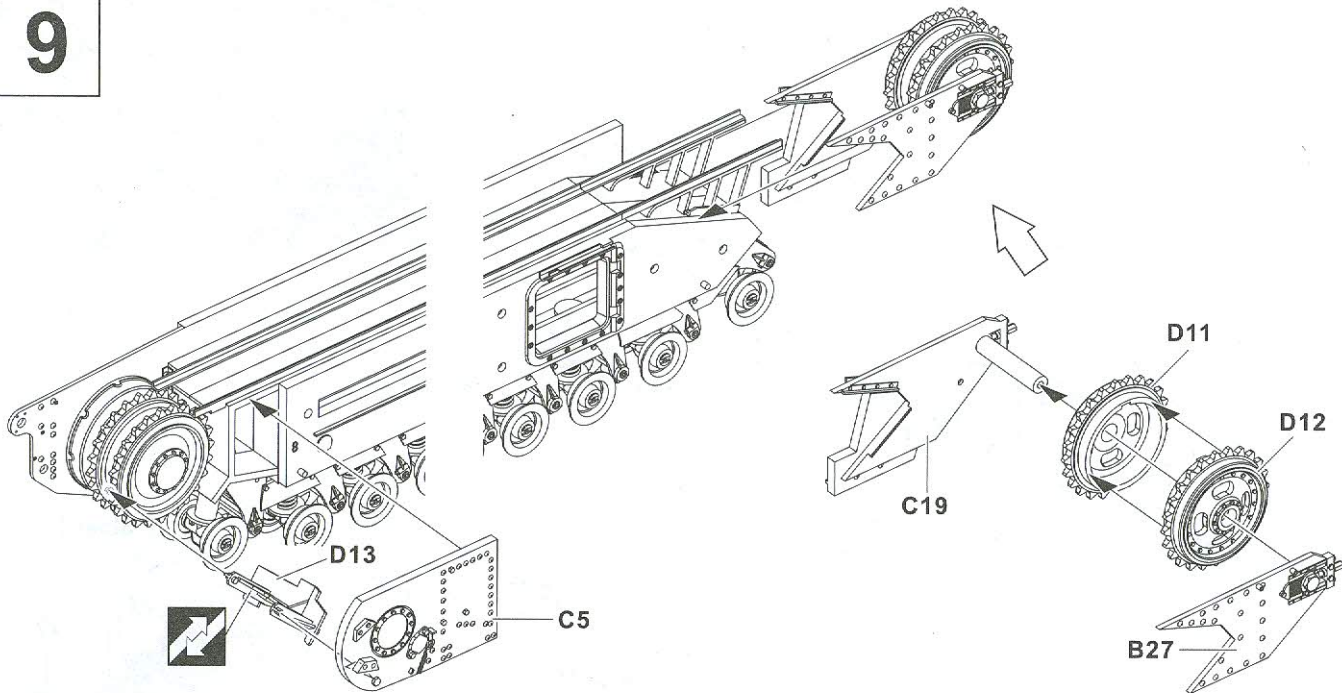

10

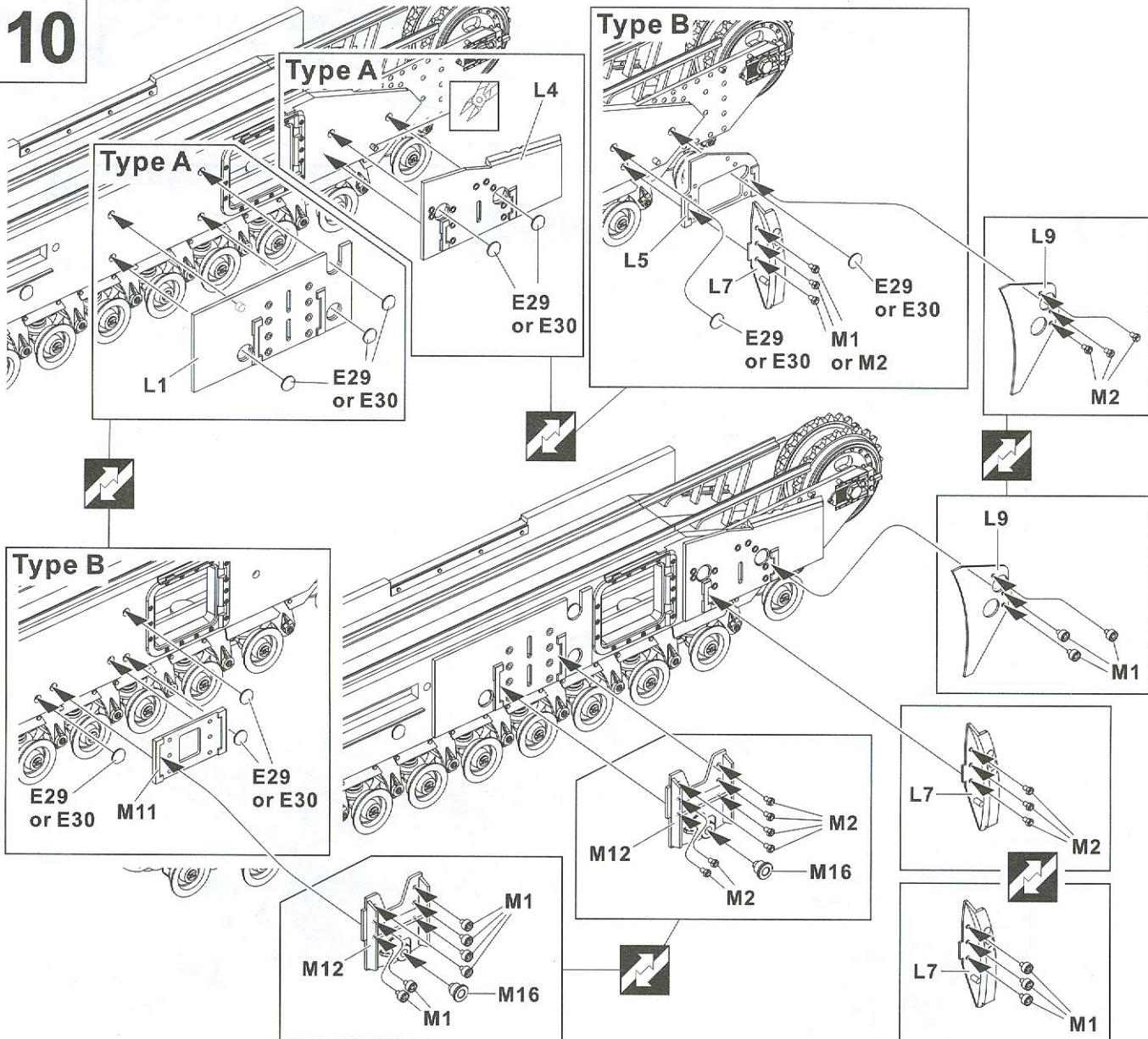

11

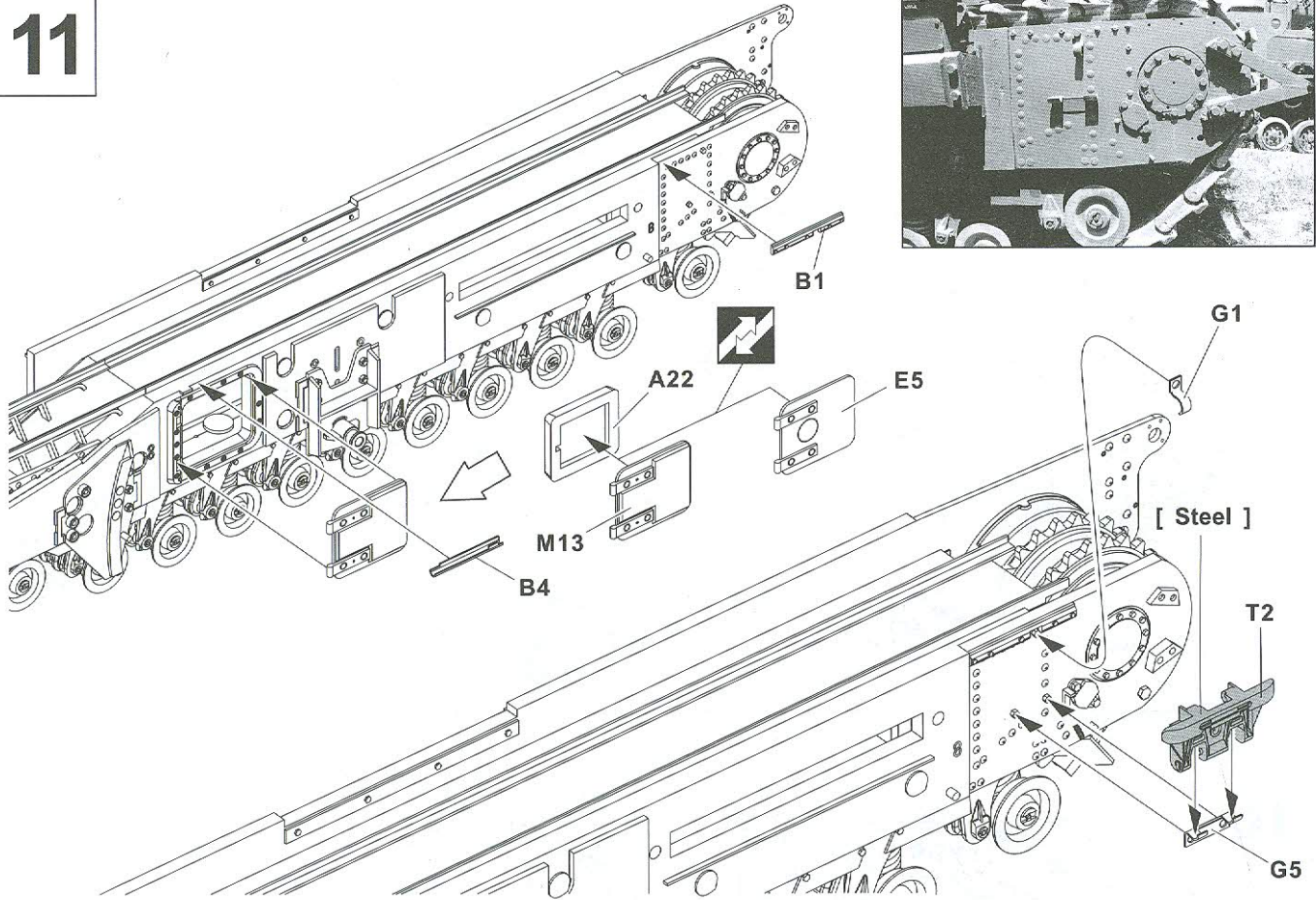
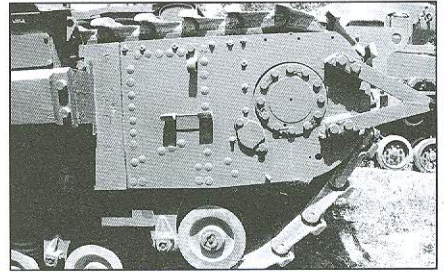

12

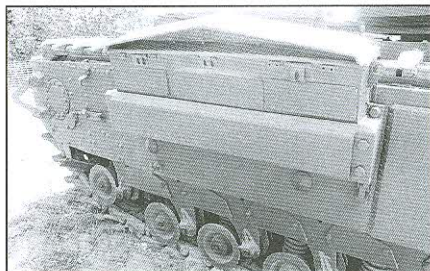
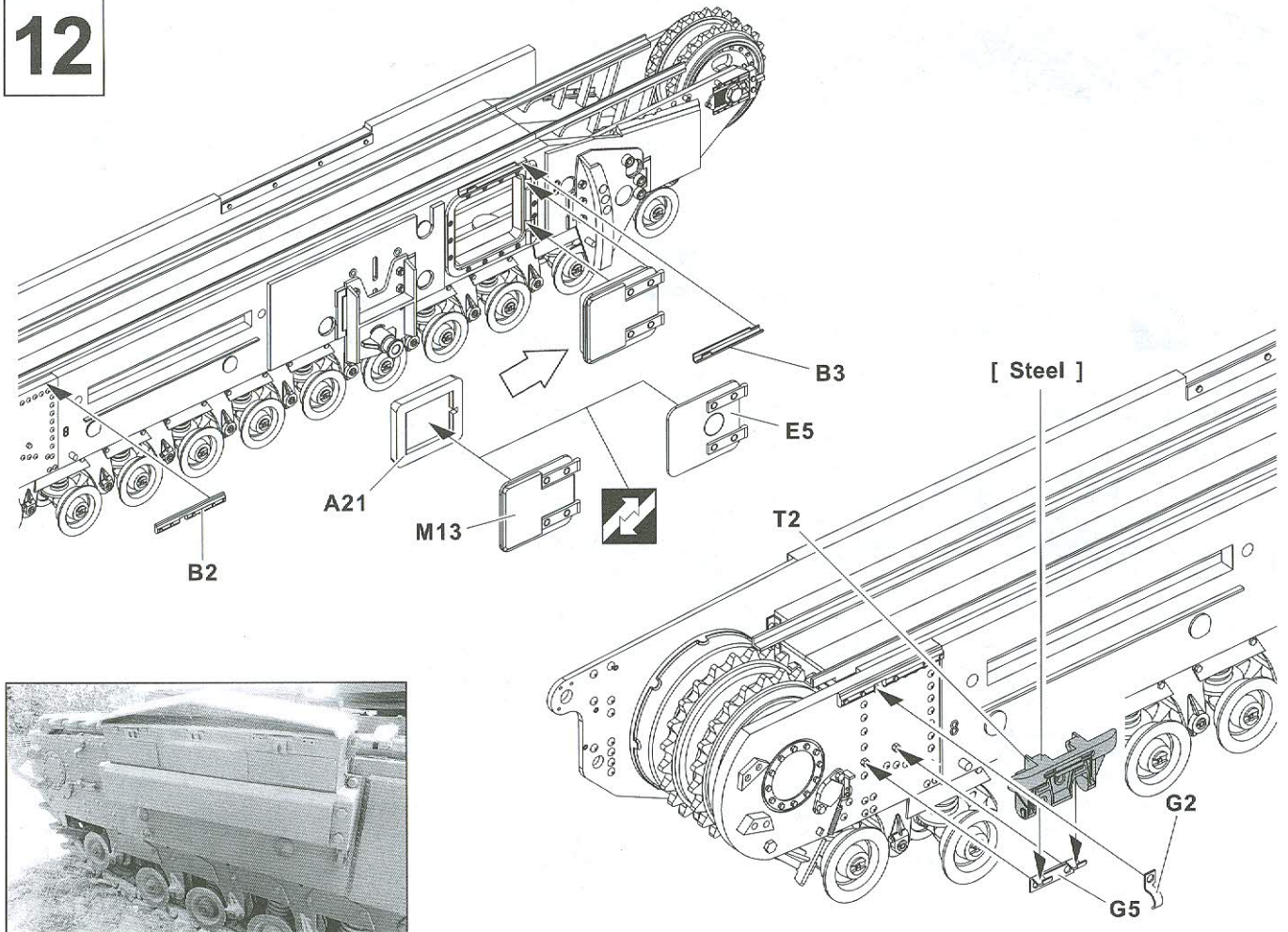

13

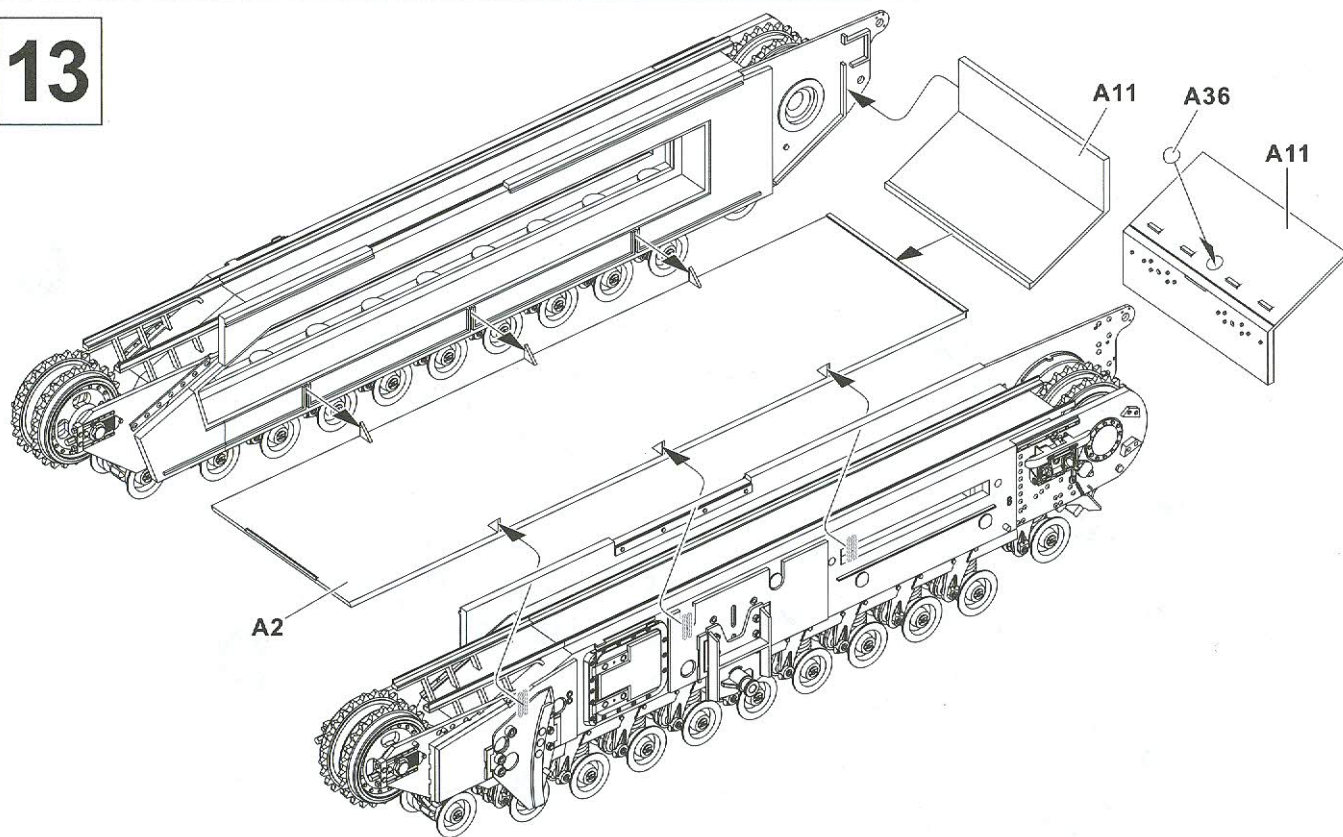

14

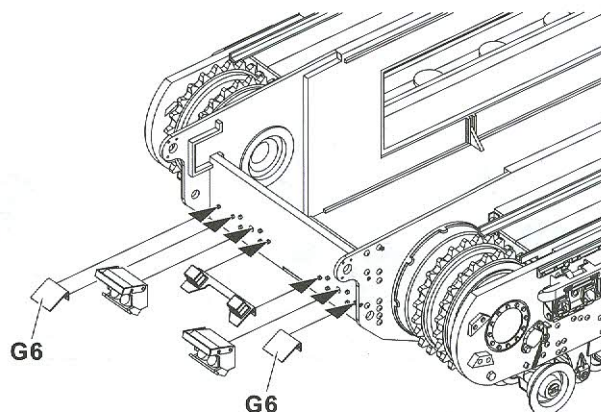
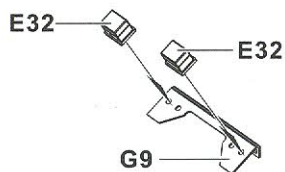
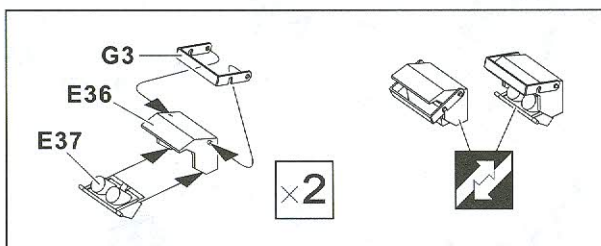

15

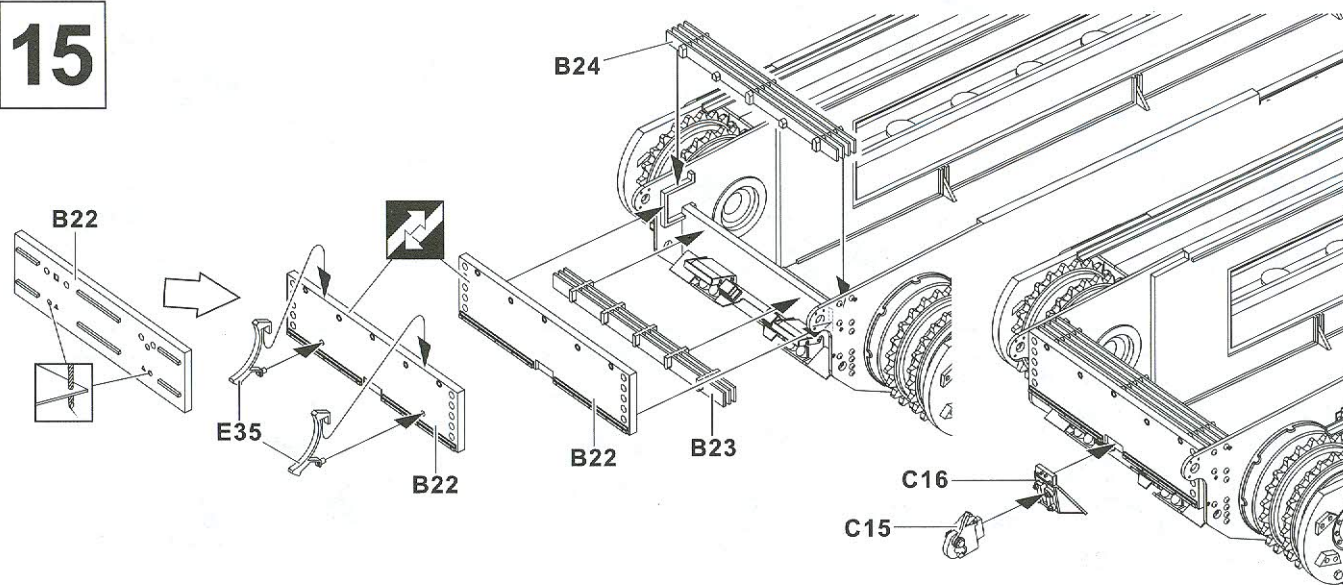

16

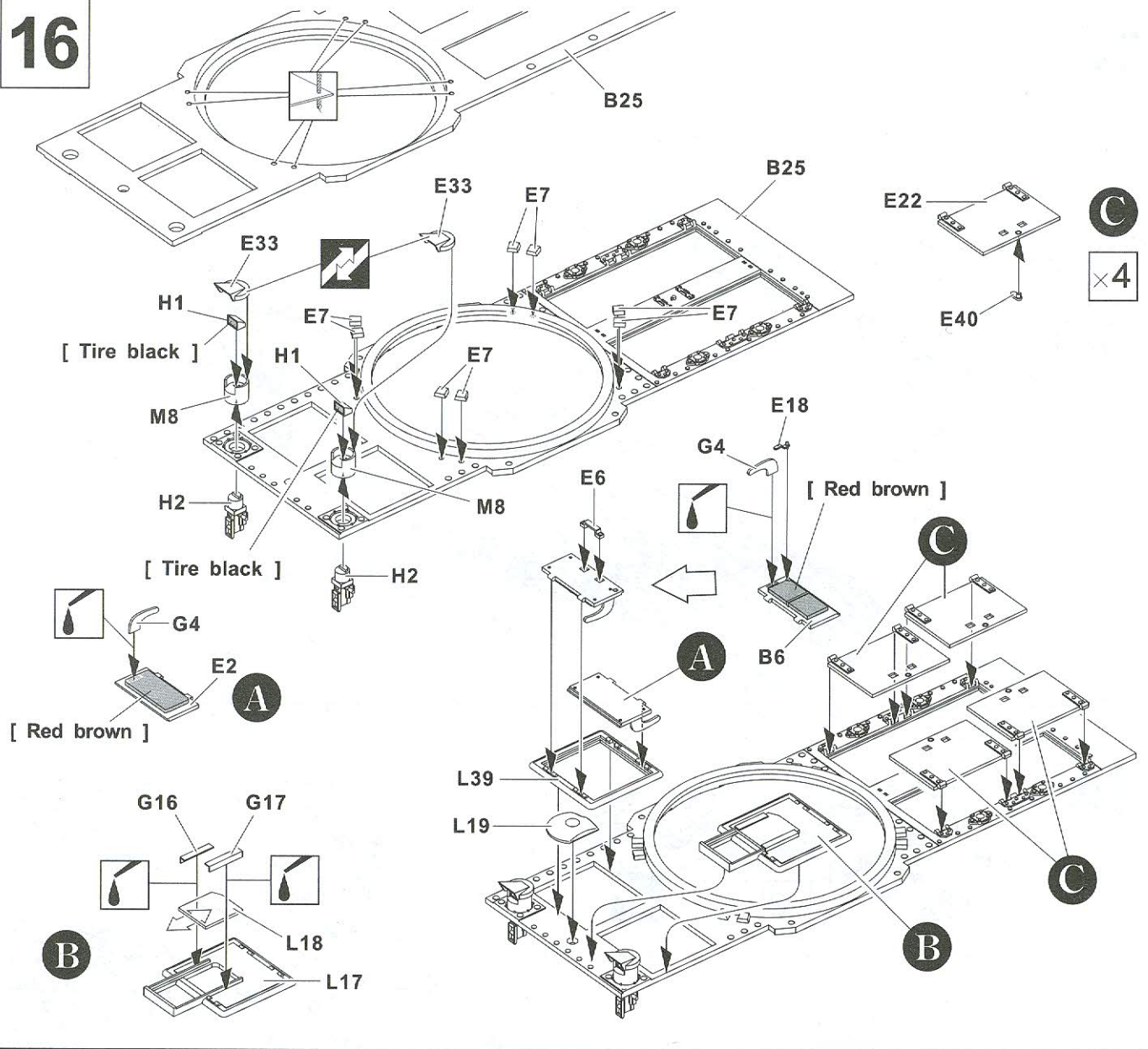

17

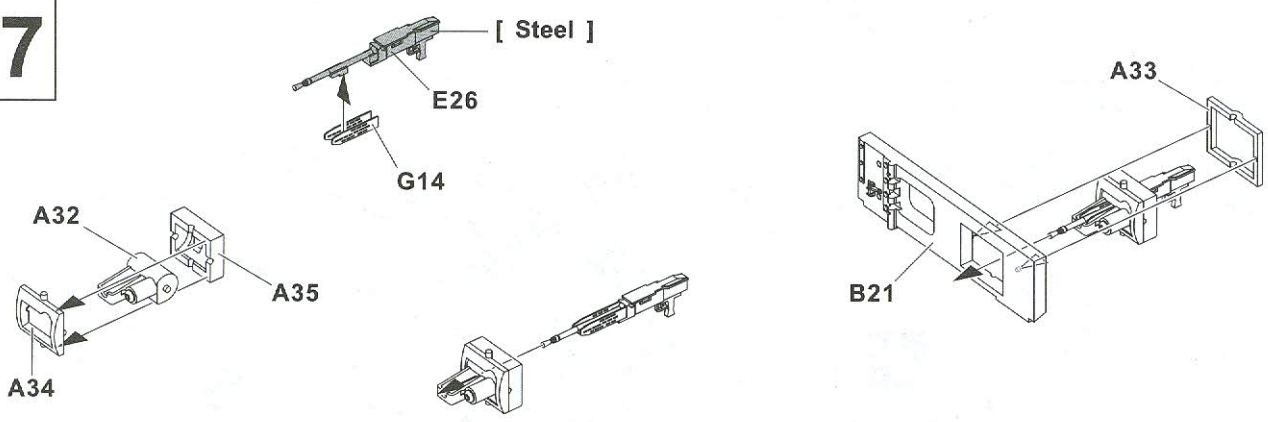

18

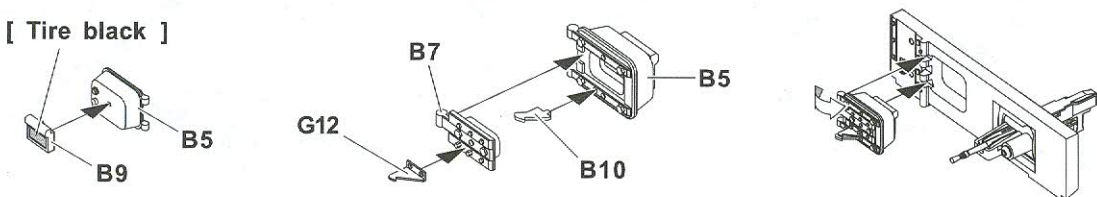

19

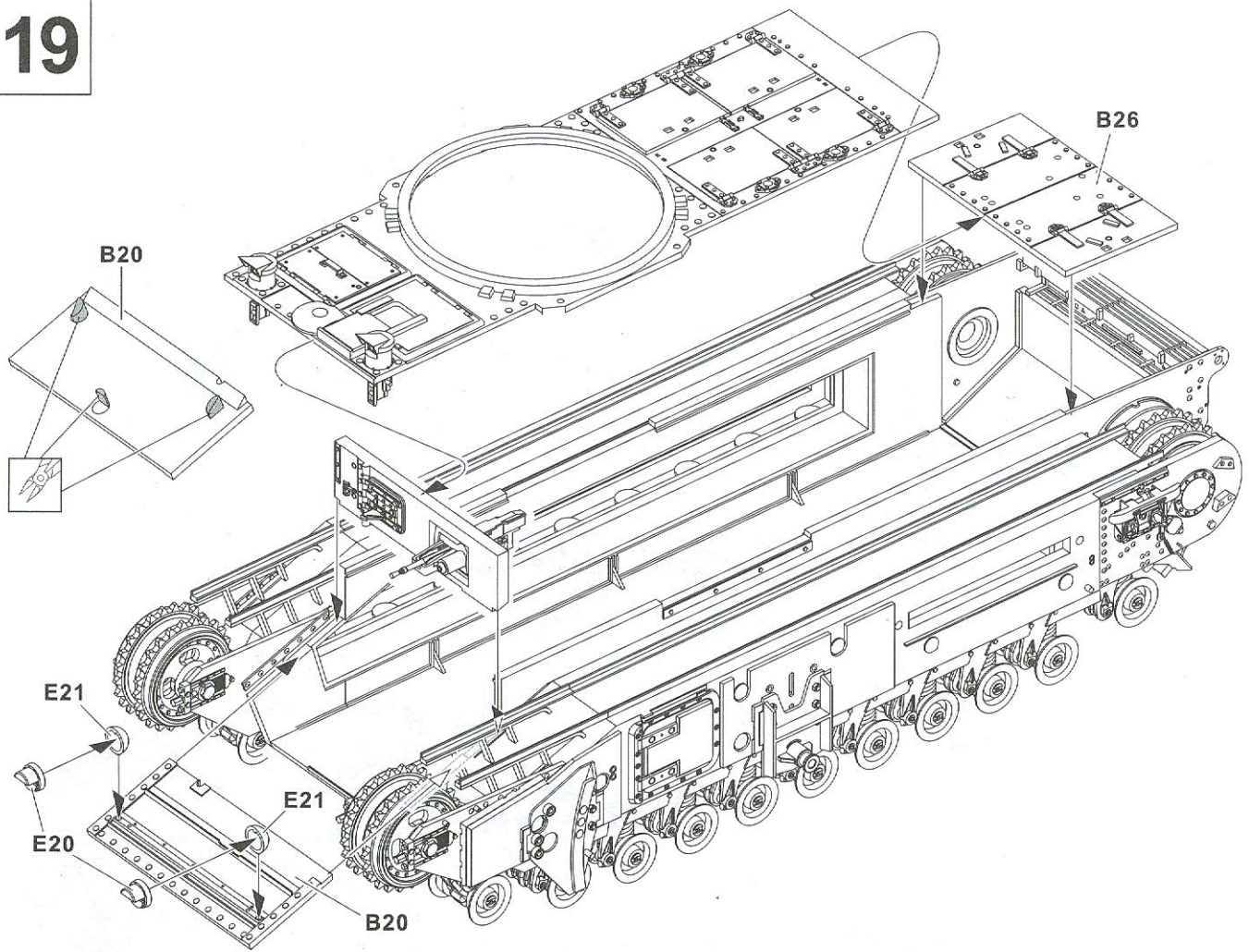

20

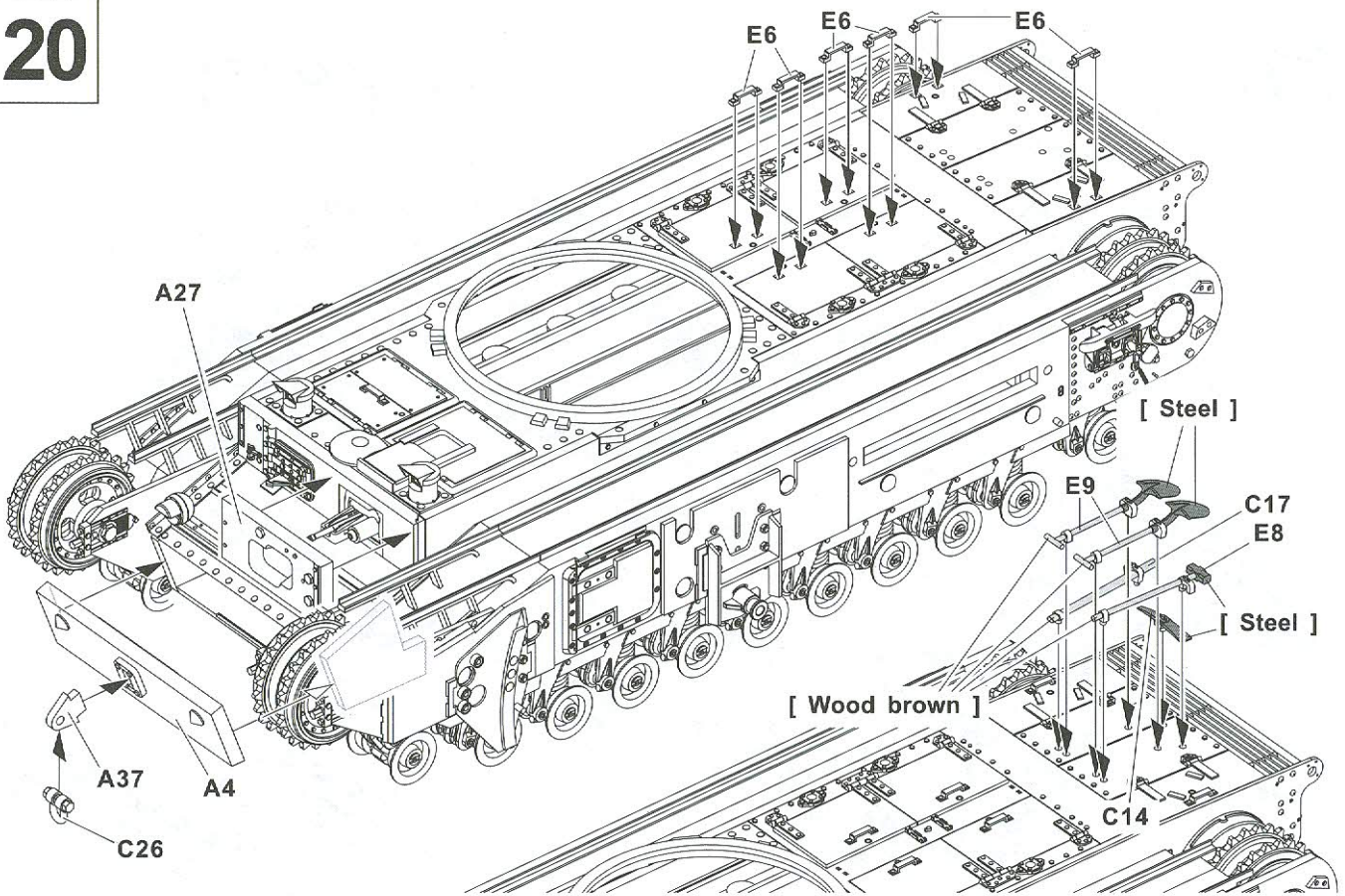

21

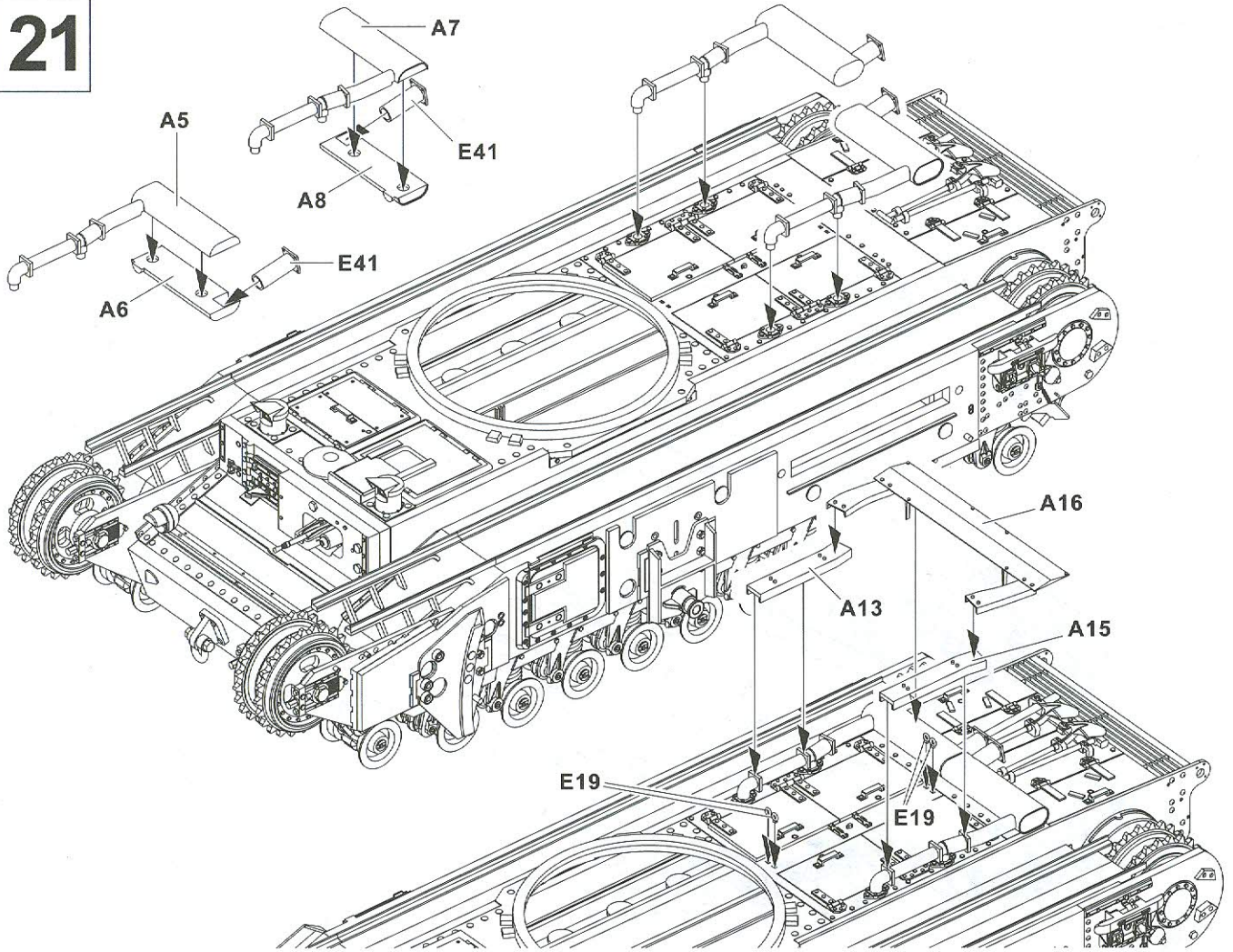

22

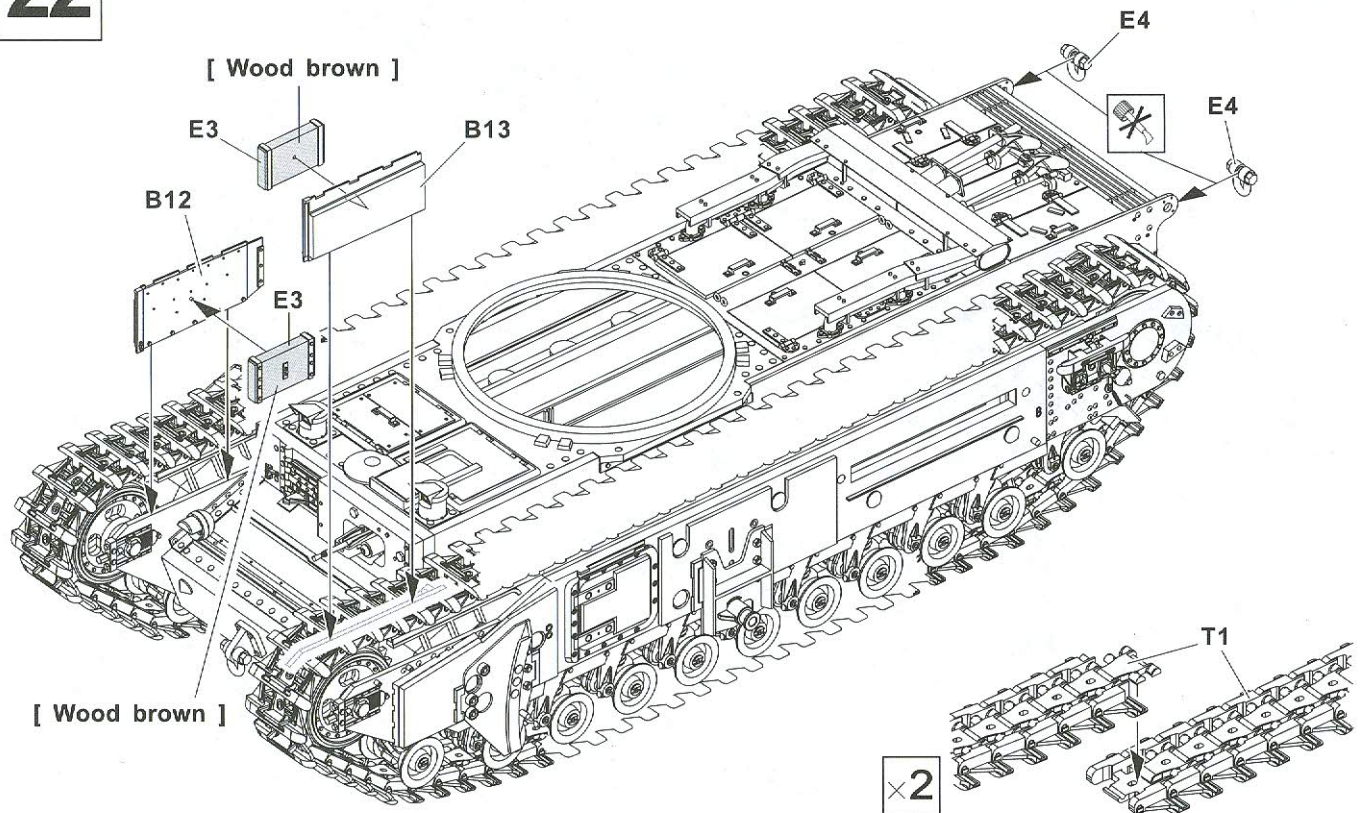

23

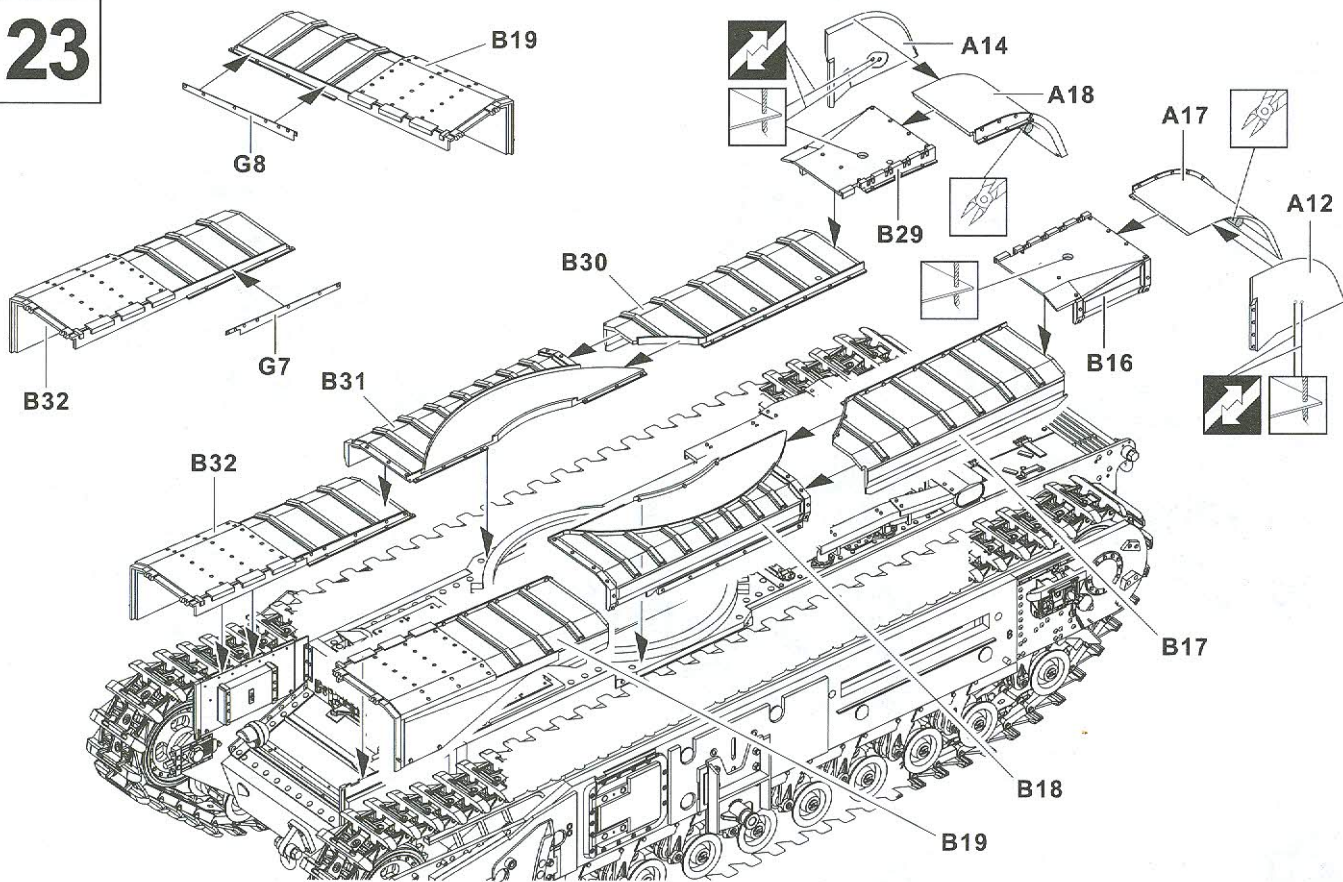

24

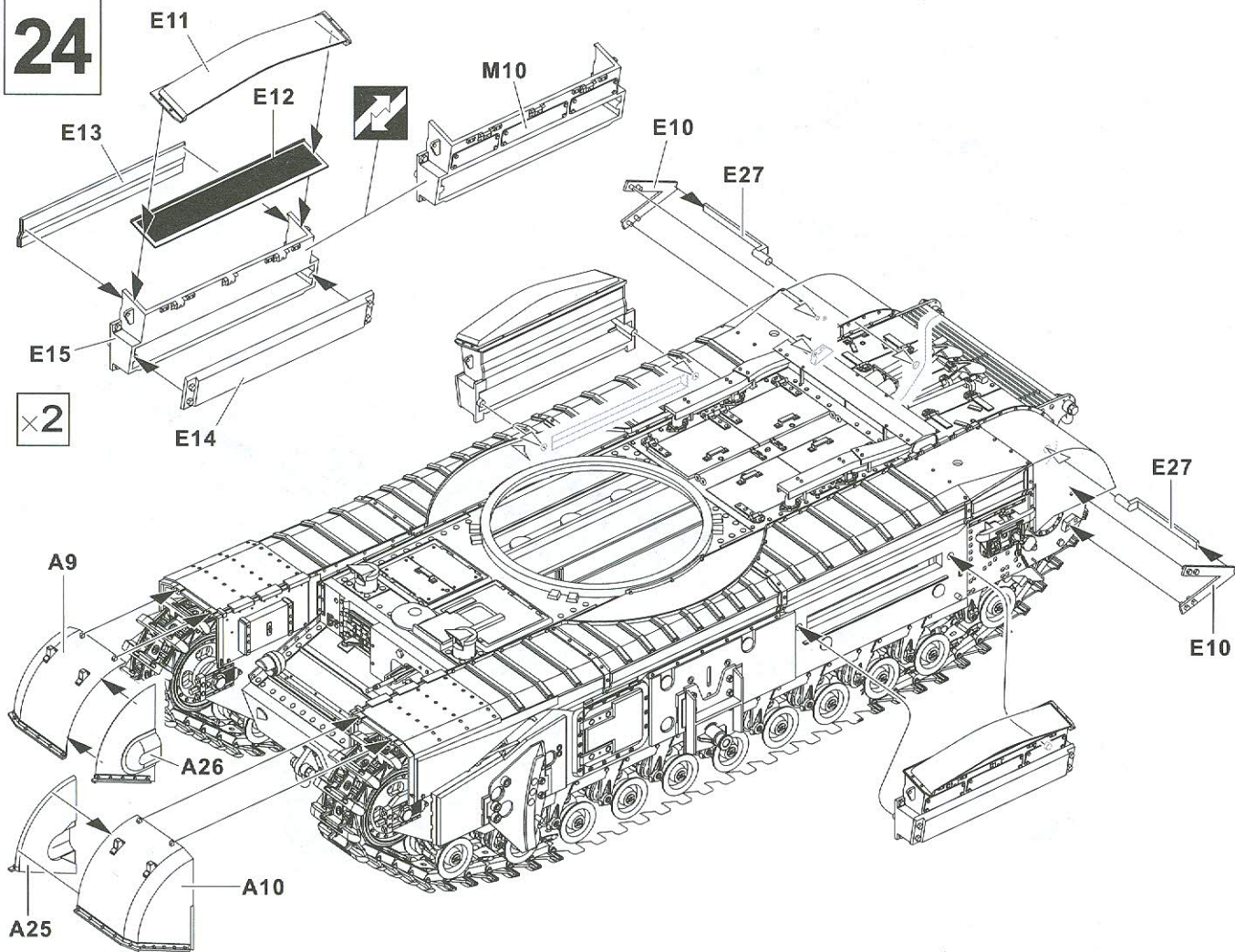

25

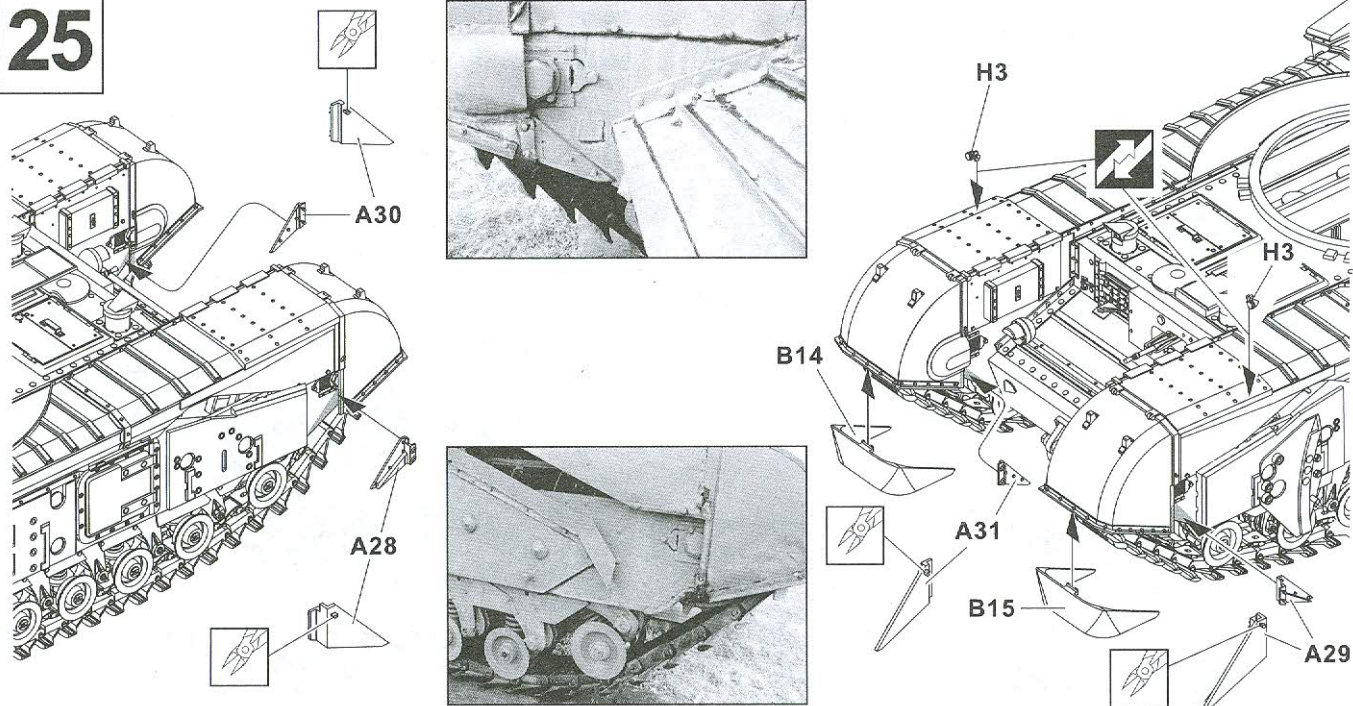

26

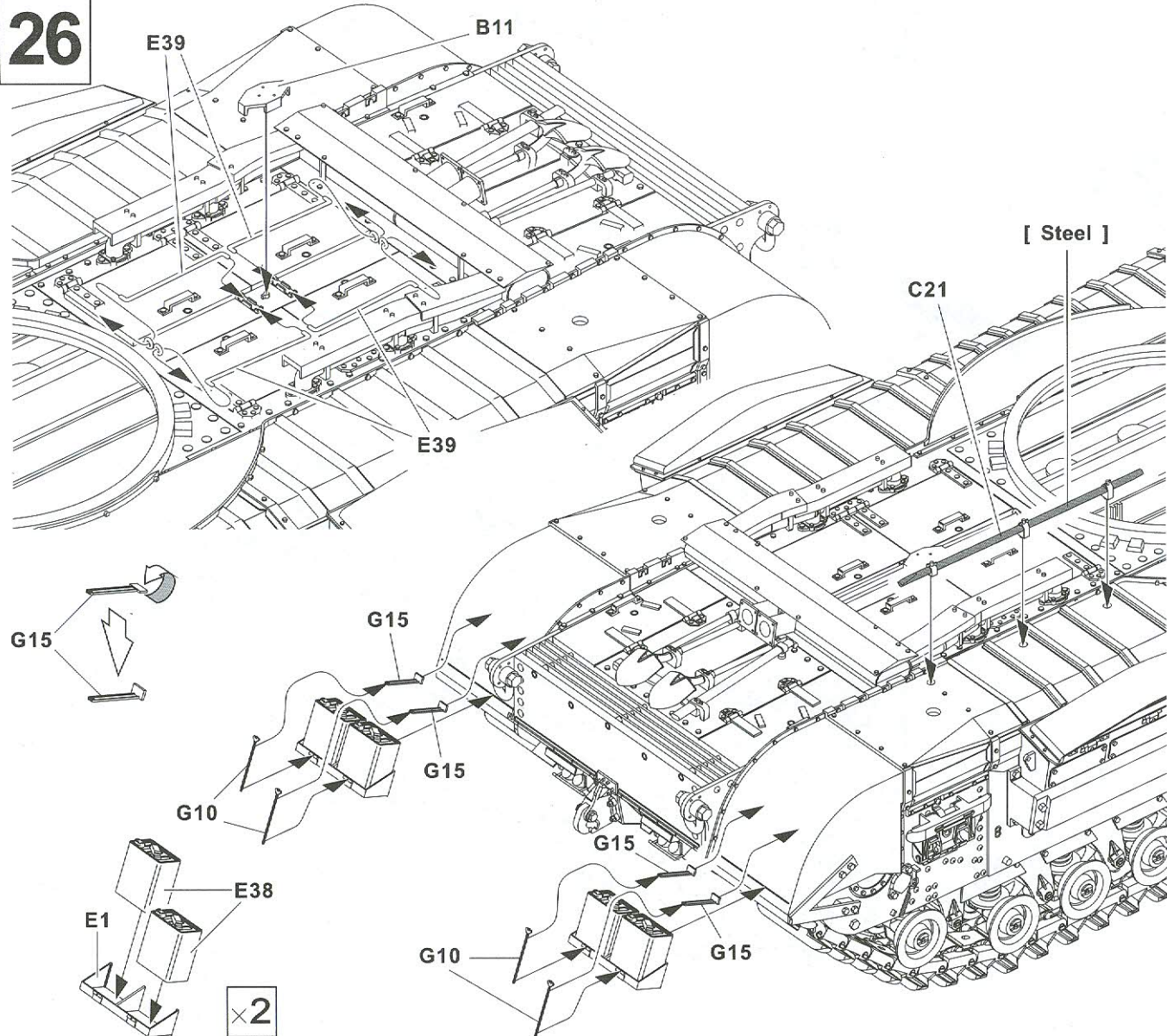

27

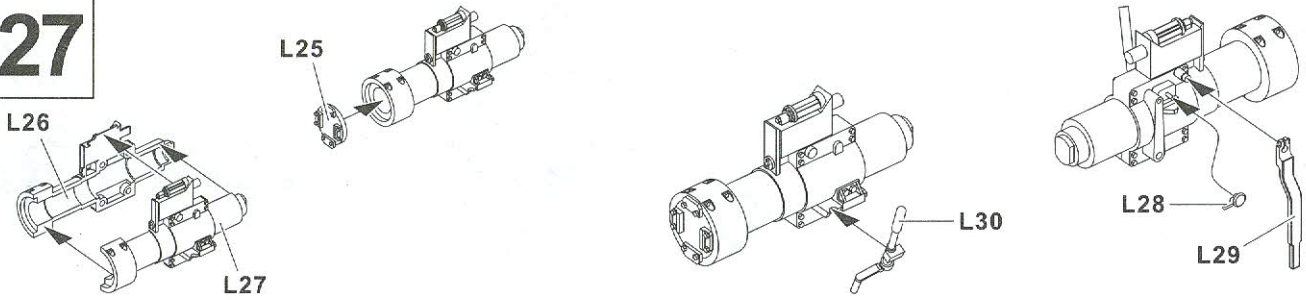

28

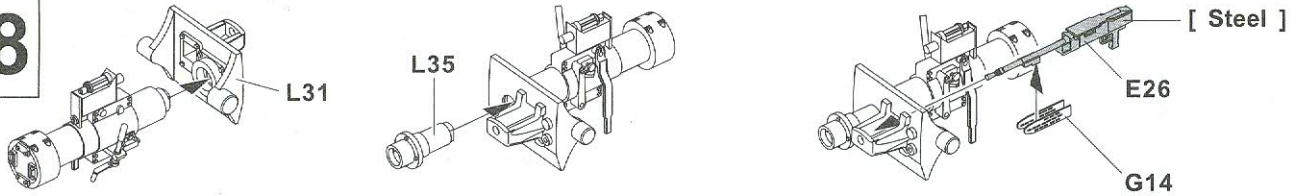

29

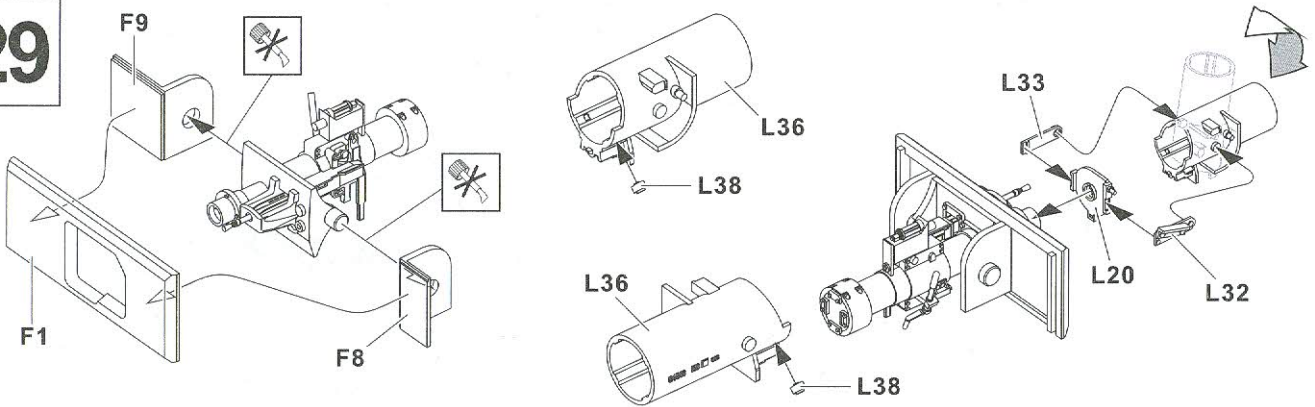

30

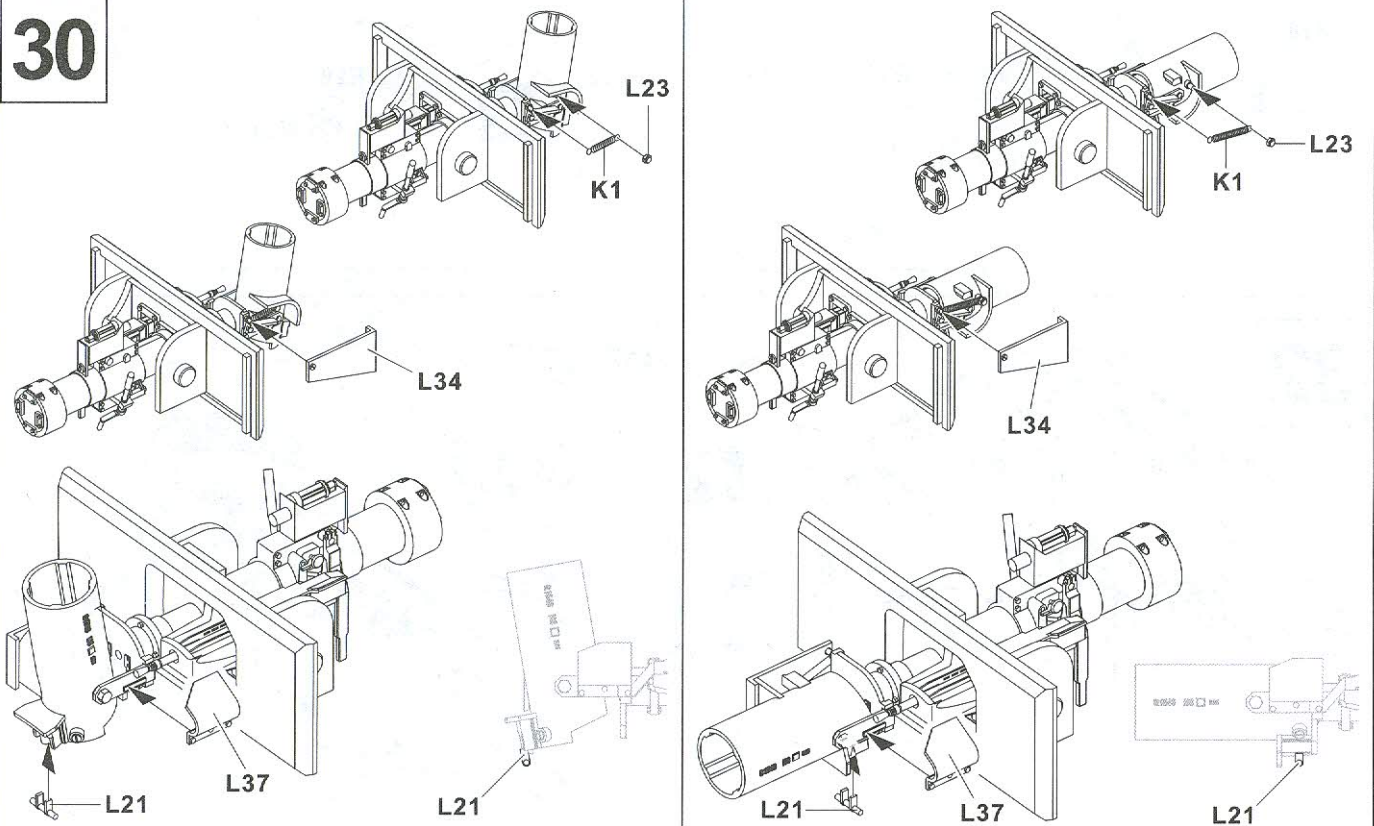

31

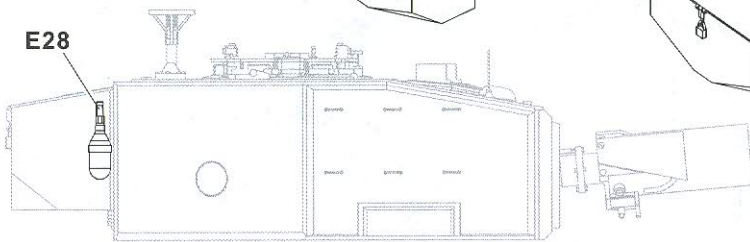
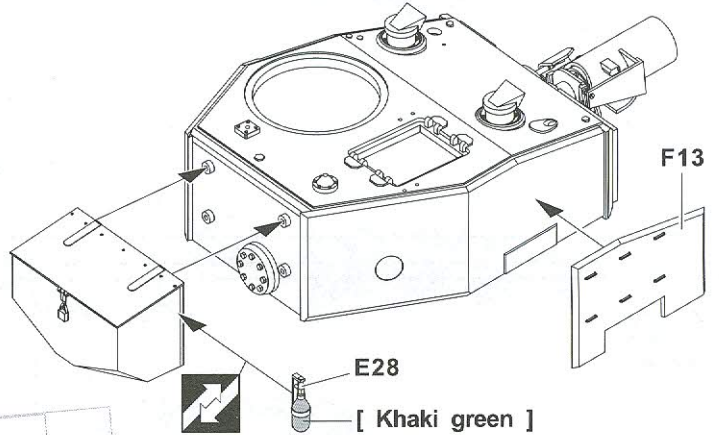
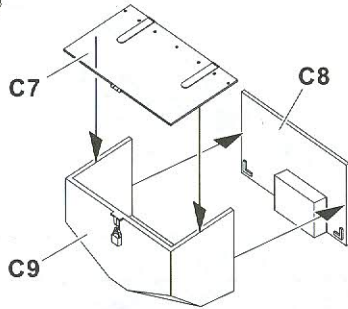
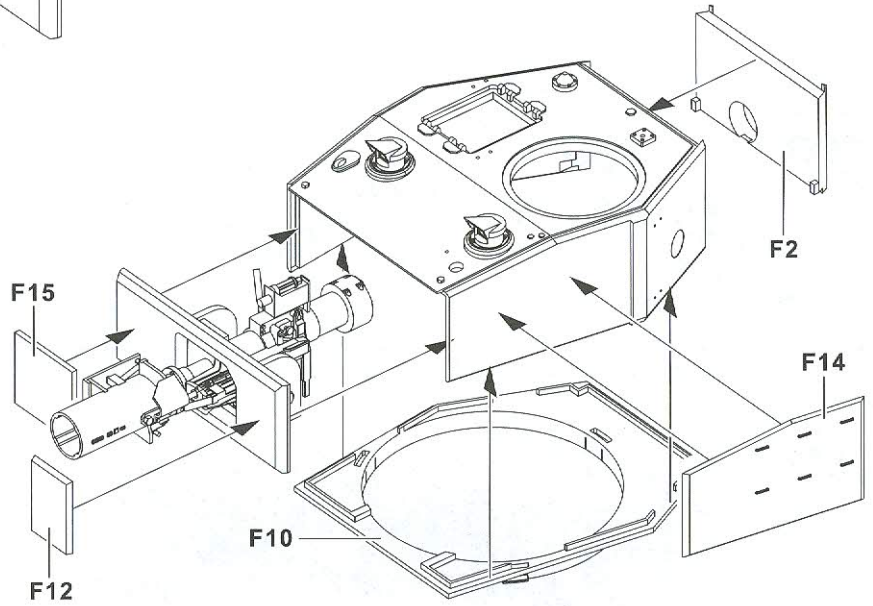
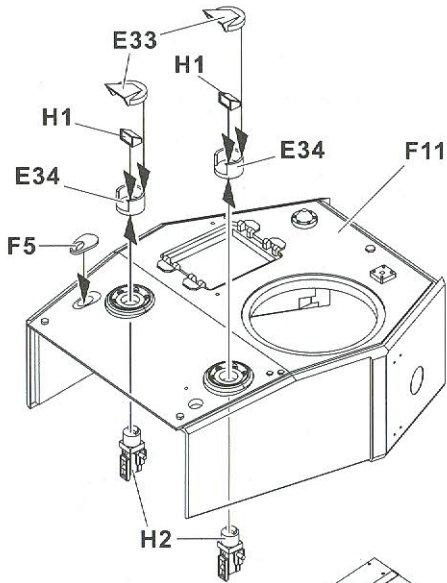
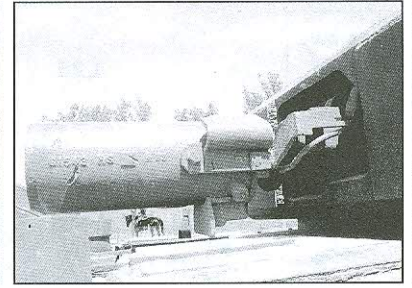
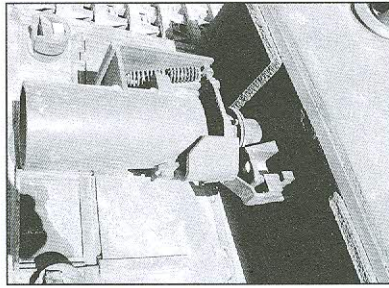
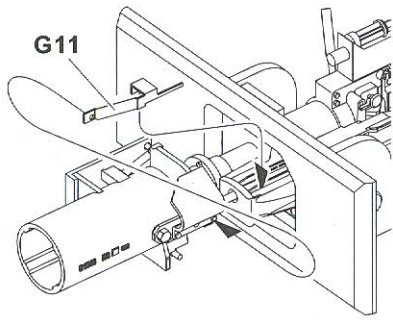

32

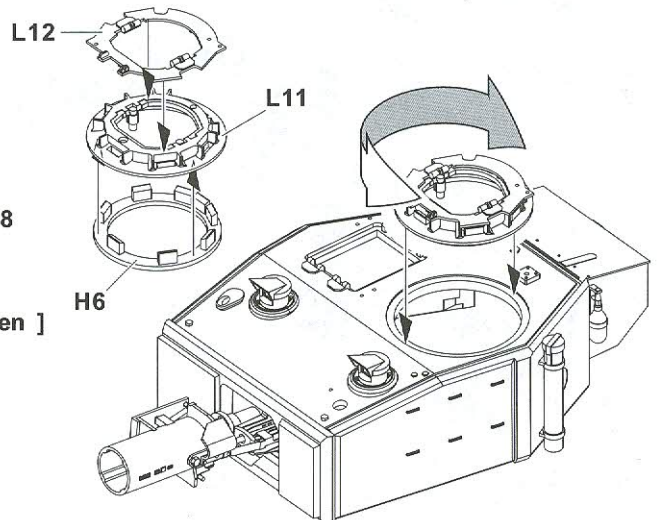
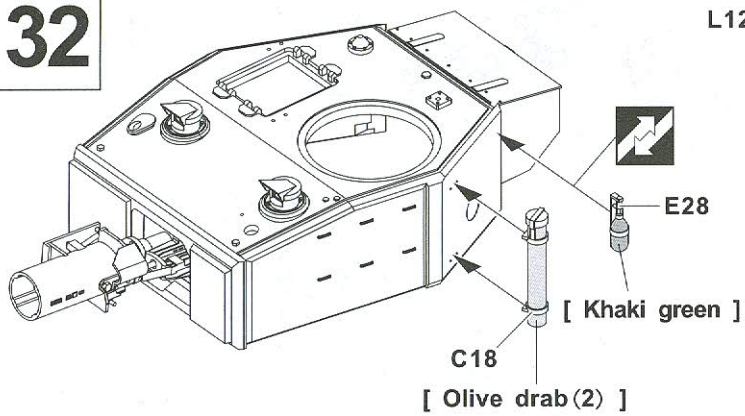

33

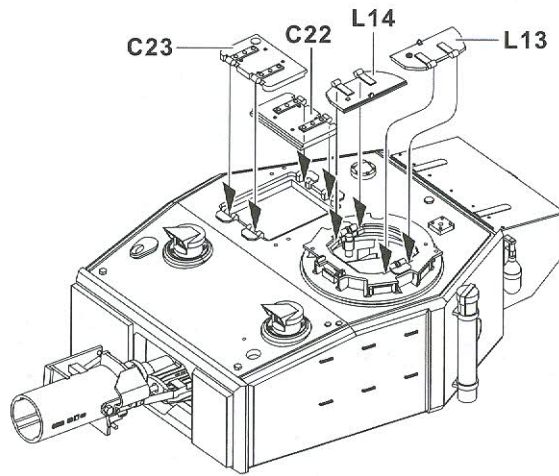
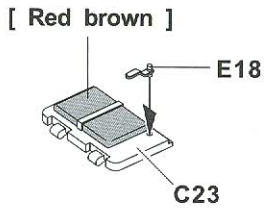
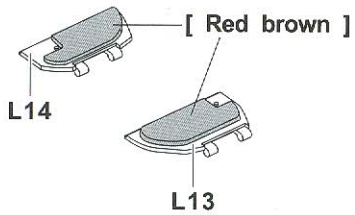

34

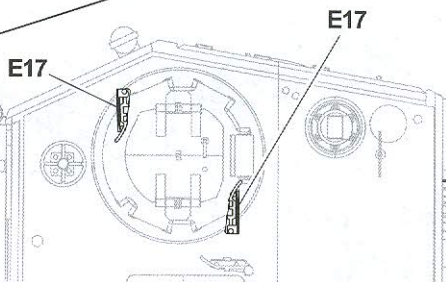
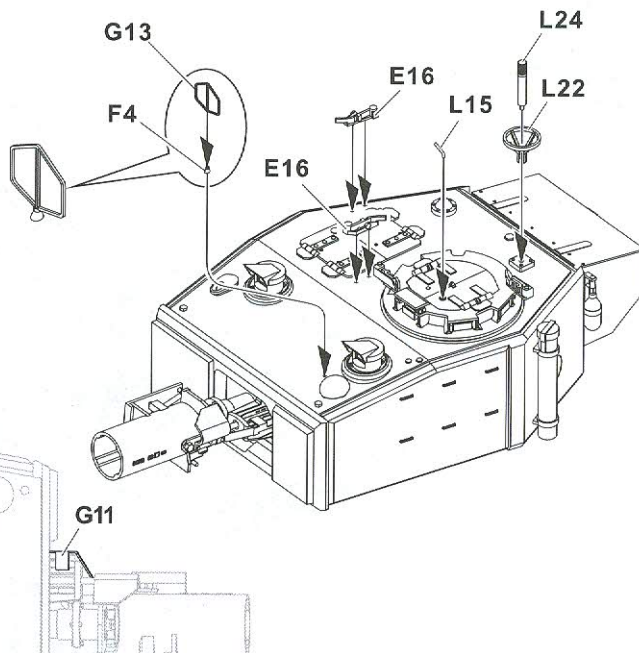
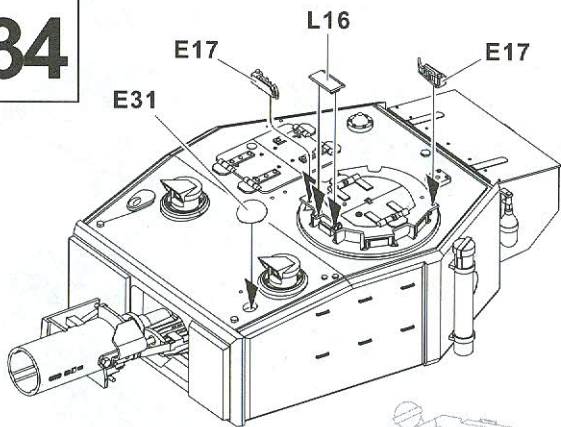

35

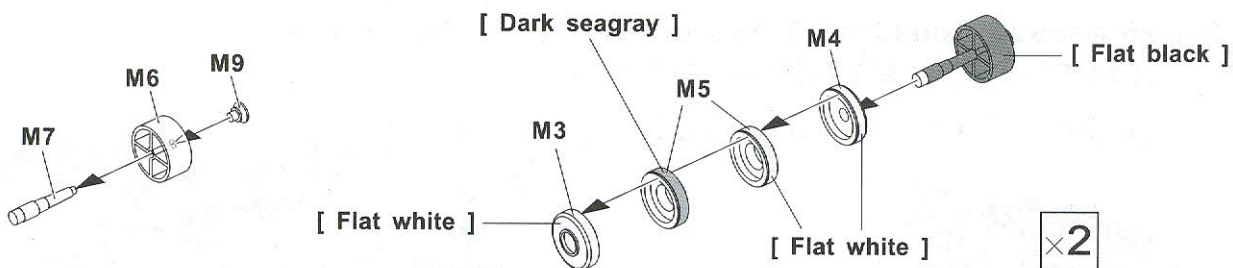

36

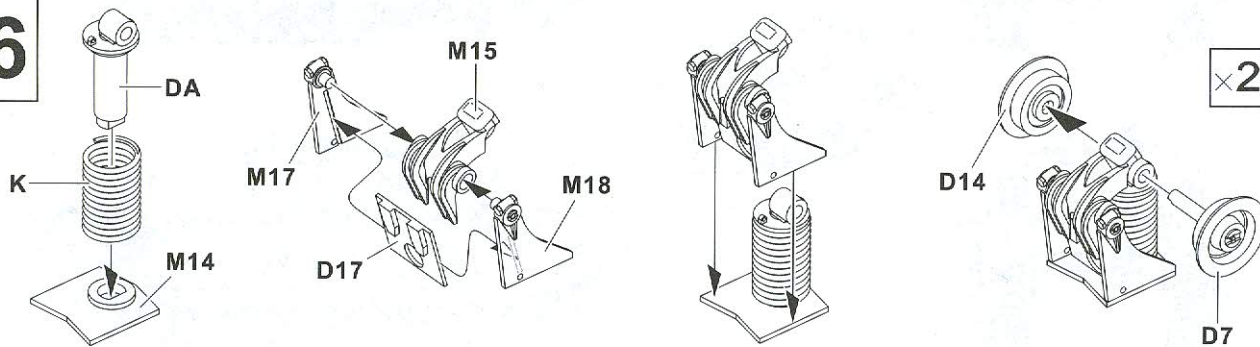

37

Length:110mm

[Steel]

×2

E42

3cm

Pull

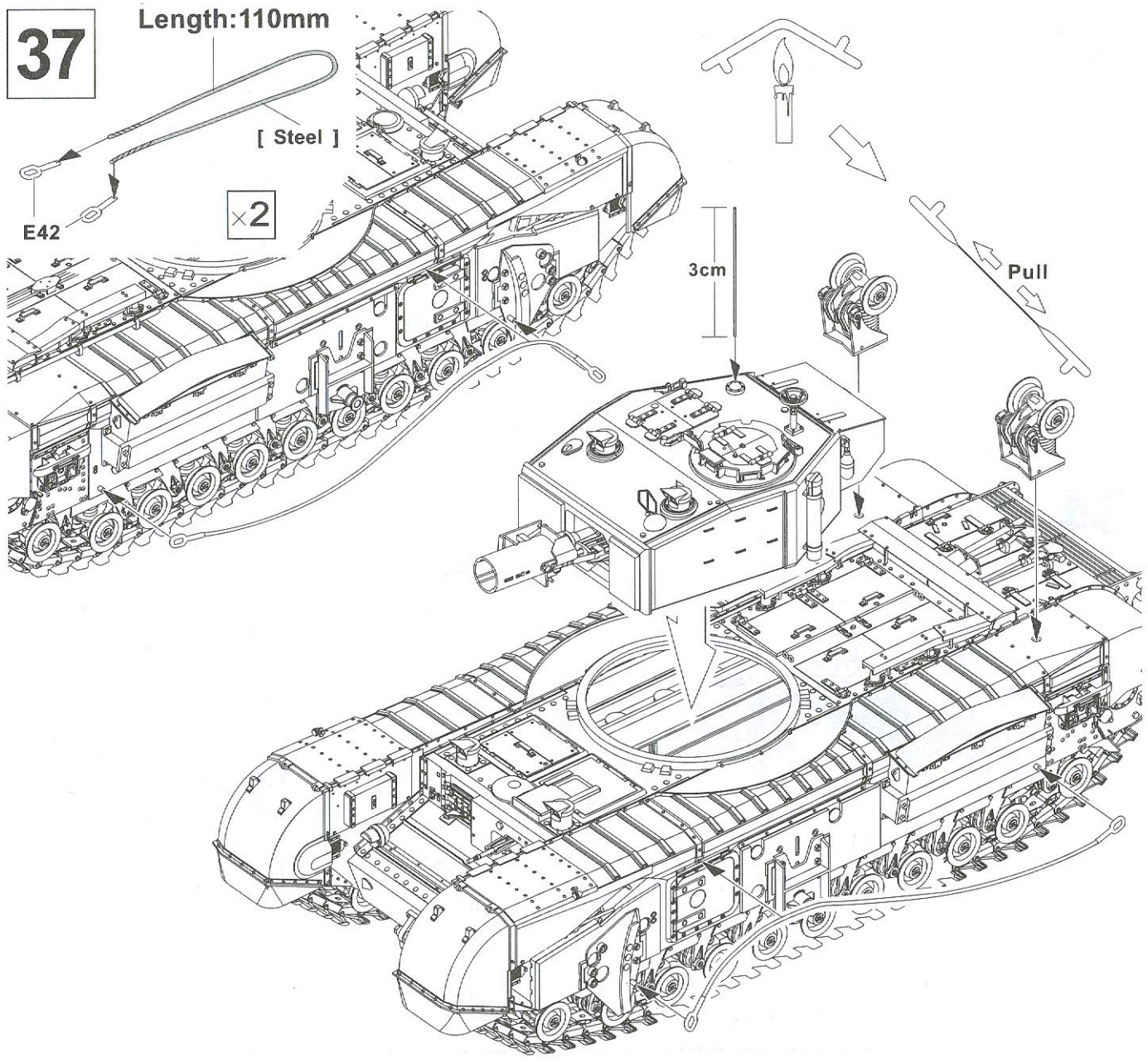

A 26 Assault Squadron 5 Assault Brigade D-DAY 6 June 1944
 1944年D日,第5突擊工兵旅,第26突擊中隊

 Body Color: Dark Green

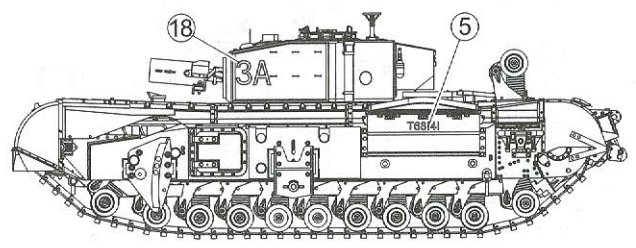
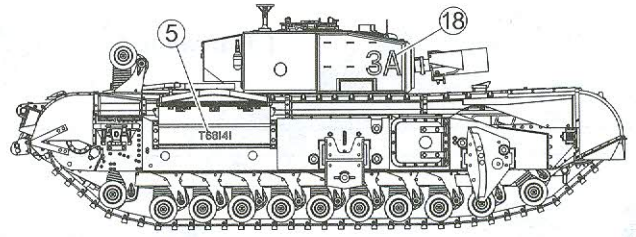
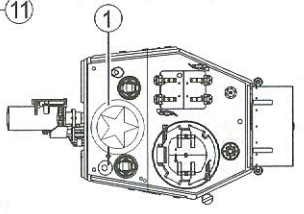
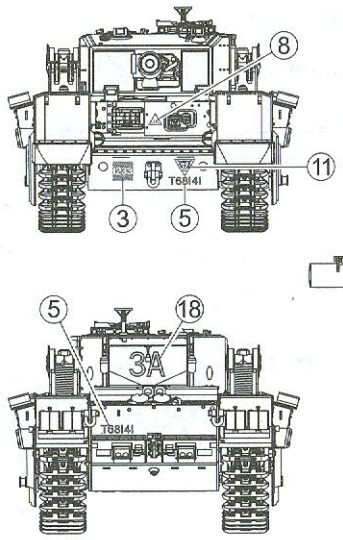

B 82 Assault Squadron 6 Assault Brigade D-DAY 6 June 1944
 1944年D日,第6突擊工兵旅,第82突擊中隊

 Body Color: Dark Green

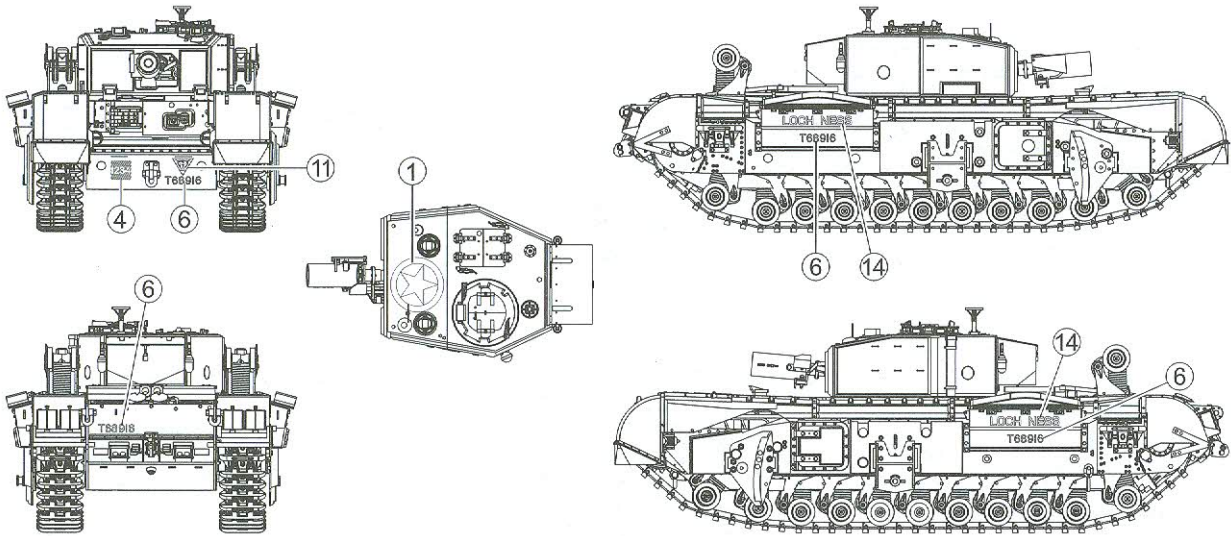

C F Assault Squadron Black half 'A' Armd Regt RE italy 1945
 1945年義大利,第6皇家工兵裝甲團,F突擊中隊

 Body Color: Dark Green

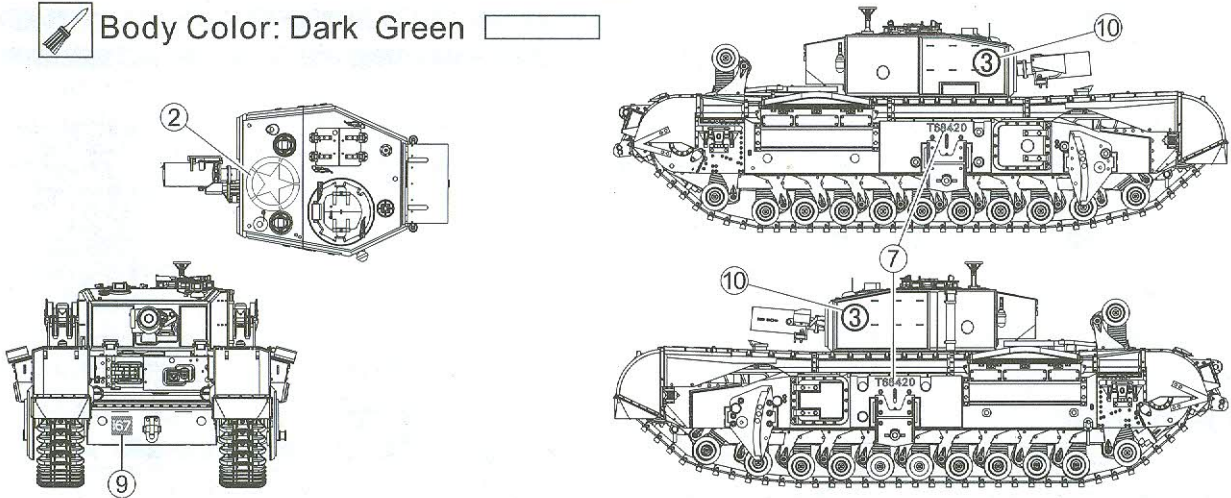

D 26 Assault Squadron 32 assault engineer regiment Germany 1949
 1949年德國,第32突擊工兵團,第26突擊中隊

 Body Color: Dark Green

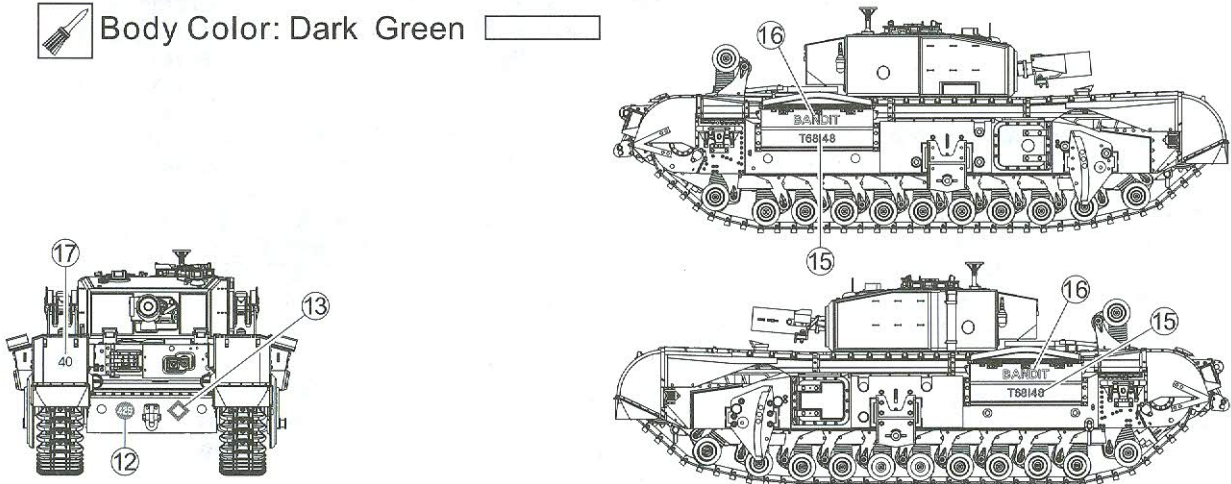

PARTS LIST 零件表

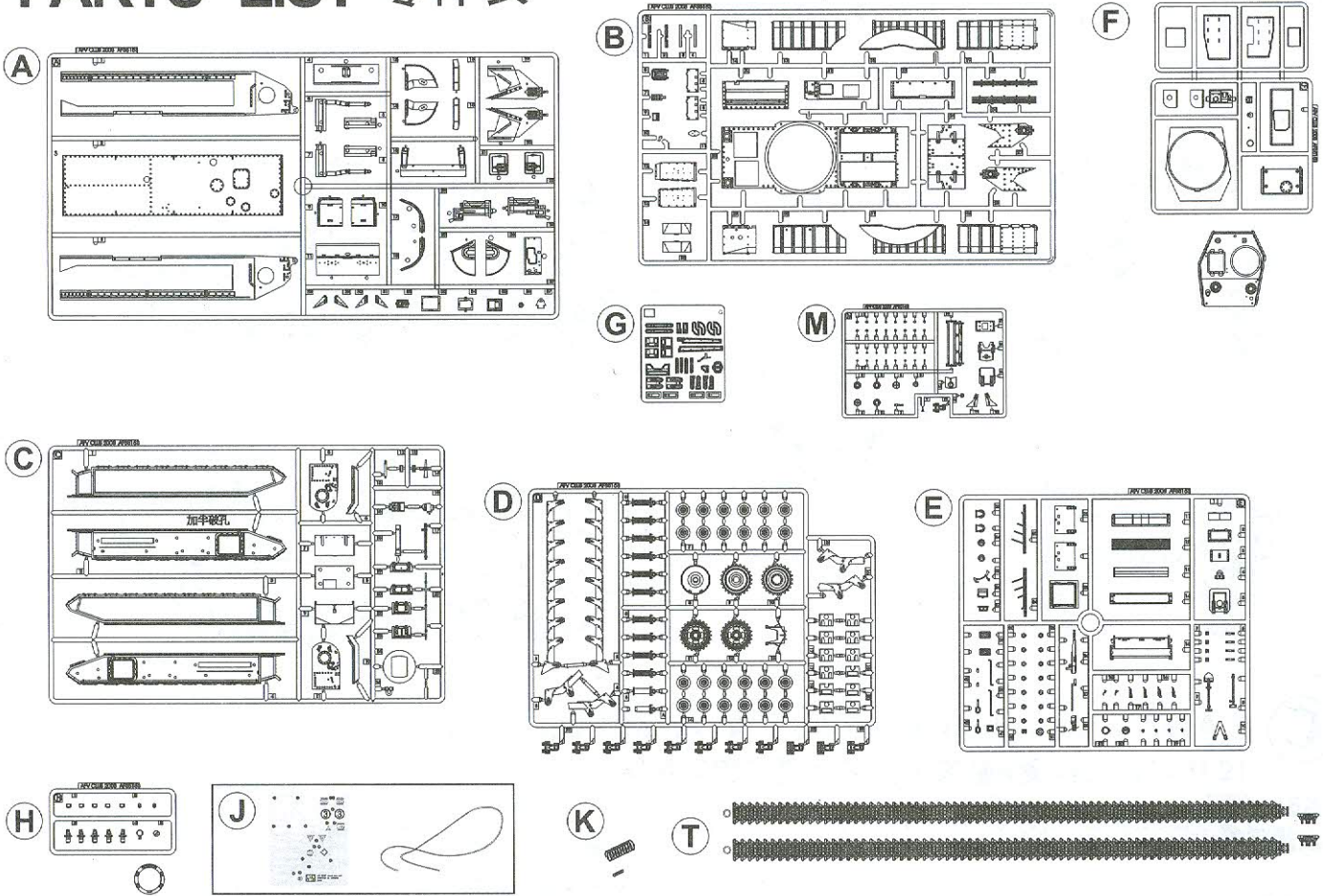

- A** — 1 **D** — 2 **G** — 1 **K** — 24+1 **T** — 1
B — 1 **E** — 2 **H** — 1 **L** — 1
C — 1 **F** — 1 **J** — 1 **M** — 2



Instructions:

If for some reason, you are not fully satisfied or have questions concerning our product; Please use the form provide, and send it to our nearest representative or mail it directly to our office.

We will deal with that A.S.A.P.



AF 35167 Parts Replacement Form

- | | | |
|----------------------------------|----------------------------------|----------------------------------|
| <input type="checkbox"/> A parts | <input type="checkbox"/> F parts | <input type="checkbox"/> L Parts |
| <input type="checkbox"/> B parts | <input type="checkbox"/> G parts | <input type="checkbox"/> M parts |
| <input type="checkbox"/> C parts | <input type="checkbox"/> H parts | <input type="checkbox"/> T parts |
| <input type="checkbox"/> D parts | <input type="checkbox"/> J parts | |
| <input type="checkbox"/> E parts | <input type="checkbox"/> K Parts | |

Reason for replacement: Missing

Signature: _____

Broken

限臺灣地區使用 For Taiwanese use only!



AF 35167 零件補充申請表

申請人
姓名 地址 電話

- | | |
|---------------------------------|----------|
| <input type="checkbox"/> A 部品零件 | NT\$ 280 |
| <input type="checkbox"/> B 部品零件 | NT\$ 280 |
| <input type="checkbox"/> C 部品零件 | NT\$ 240 |
| <input type="checkbox"/> D 部品零件 | NT\$ 320 |
| <input type="checkbox"/> E 部品零件 | NT\$ 210 |
| <input type="checkbox"/> F 部品零件 | NT\$ 180 |
| <input type="checkbox"/> G 部品零件 | NT\$ 220 |
| <input type="checkbox"/> H 部品零件 | NT\$ 120 |
| <input type="checkbox"/> J 部品零件 | NT\$ 160 |
| <input type="checkbox"/> K 部品零件 | NT\$ 160 |
| <input type="checkbox"/> L 部品零件 | NT\$ 280 |
| <input type="checkbox"/> M 部品零件 | NT\$ 320 |
| <input type="checkbox"/> T 部品零件 | NT\$ 280 |

+郵寄費 — NT\$ 80
(請填) 總計 NT\$ _____

零件補充原因:(請於 打)

原包裝即 遺失或 毀損,

製作途中 遺失或 毀損,

其他原因 _____

總代理戰鷹企業有限公司收本公司將儘速為您處理。
請將本表與該部品相同金額之郵政匯票一同寄至